

DETAIL "A"

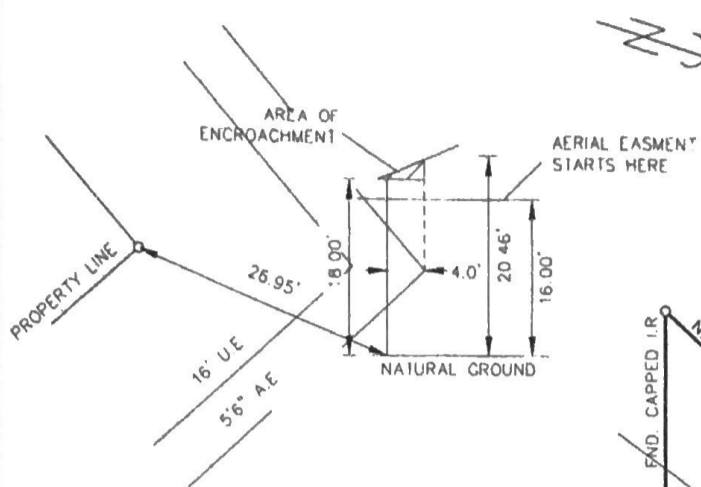

DETAIL "B"

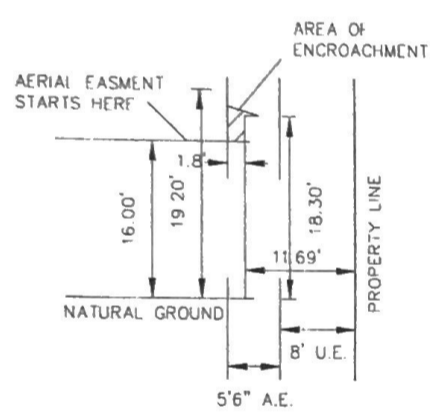

NOTE:
 1. Distances shown in parentheses were measured on the ground.
 2. The following flood information was from a F.E.M.A. Map. We are not responsible for its accuracy.

COMMUNITY # 480228 PANEL # 0240 J

NOTES:
 1. OIL, GAS, & OTHER MINERAL RIGHTS AS PER TITLE COMMITMENT.
 2. AN AGREEMENT WITH RELIANT ENERGY FOR DISTRIBUTION PURPOSES, C.F. NO. 2002074386
 3. CONSENT TO ENCROACHMENT INTO THE ABOVE SAID EASEMENT BETWEEN DEERWOOD HOMES BRAZOS, L.P., AND CENTERPOINTE ENERGY, BEING MORE PARTICULARLY DESCRIBED BY SKECH ATTACHED THERETO AND BY C.F.# 2003094995.
 4. TRANSFER FEE RESERVED IN C.F.# 2002031417.

DATE OF REVISION 01/03/97
 (OUTSIDE OF 100 YEAR FLOOD PLAIN)

SCALE : 1"=20'

JW: \FINALS\CGB140108

Surveyed for DEERWOOD HOMES on 4/11/03
 Showing Lot 14 Block 1 of CANYON GATE @ THE BRAZOS
 Section 8 in FORT BEND County Texas according to the Map or Plat
 recorded in Slide No. 2278/B of the PLAT records of FORT BEND County.

REVISIONS	
8/29/03	FINAL

I hereby certify that this survey was made on the ground under my supervision and that it correctly represents the facts found at the time of the survey. There were no encroachments apparent on the ground except as shown hereon.

W.O. No. 84097, 7277
 G.F. No. 03302165

Thomas H. Eikel



Buyer: JOSE CAVAZOS
 Mortgage Co.: _____
 Title Company: STEWART TITLE COMPANY

Hoffman Land Surveying, Ltd.,LLP
 5245 LANGFIELD ROAD - HOUSTON, TEXAS 77040 - (713)939-9100

