



WILLCOX INSPECTIONS LLC™

Real Inspections. Sound Information.™

1431 Wirt Road #163 Houston, Texas 77055
713-461-0009

PROPERTY INSPECTION REPORT

Prepared For: Joshua and Alexis FitzPatrick
(Name of Client)

Concerning: 1505 Detering, Houston, TX 77007
(Address or Other Identification of Inspected Property)

By: Shavauna Higgins Professional Inspector #3472 08-17-16
(Name and License Number of Inspector) (Date)

File No. 22150 713-461-0009 www.willcoxinspections.com

PURPOSE, LIMITATIONS AND INSPECTOR / CLIENT RESPONSIBILITIES

This property inspection report may include an inspection agreement (contract), addenda, and other information related to property conditions. If any item or comment is unclear, you should ask the inspector to clarify the findings. It is important that you carefully read ALL of this information.

This inspection is subject to the rules (“Rules”) of the Texas Real Estate Commission (“TREC”), which can be found at www.trec.texas.gov.

The TREC Standards of Practice (Sections 535.227-535.233 of the Rules) are the minimum standards for inspections by TREC-licensed inspectors. An inspection addresses only those components and conditions that are present, visible, and accessible at the time of the inspection. While there may be other parts, components or systems present, only those items specifically noted as being inspected were inspected. The inspector is NOT required to turn on decommissioned equipment, systems, utility services or apply an open flame or light a pilot to operate any appliance. The inspector is NOT required to climb over obstacles, move furnishings or stored items. The inspection report may address issues that are code-based or may refer to a particular code; however, this is NOT a code compliance inspection and does NOT verify compliance with manufacturer’s installation instructions. The inspection does NOT imply insurability or warrantability of the structure or its components. Although some safety issues may be addressed in this report, this inspection is NOT a safety/code inspection, and the inspector is NOT required to identify all potential hazards.

In this report, the inspector shall indicate, by checking the appropriate boxes on the form, whether each item was inspected, not inspected, not present or deficient and explain the findings in the corresponding section in the body of the report form. The inspector must check the Deficient (D) box if a condition exists that adversely and materially affects the performance of a system or component or constitutes a hazard to life, limb or property as specified by the TREC Standards of Practice. General deficiencies include inoperability, material distress, water penetration, damage, deterioration, missing components, and unsuitable installation. Comments may be provided by the inspector whether or not an item is deemed deficient. The inspector is not required to prioritize or emphasize the importance of one deficiency over another.

Some items reported may be considered life-safety upgrades to the property. For more information, refer to Texas Real Estate Consumer Notice Concerning Recognized Hazards or Deficiencies below.

THIS PROPERTY INSPECTION IS NOT A TECHNICALLY EXHAUSTIVE INSPECTION OF THE STRUCTURE, SYSTEMS OR COMPONENTS. The inspection may not reveal all deficiencies. A real estate inspection helps to reduce some of the risk involved in purchasing a home, but it cannot eliminate these risks,

I=Inspected

NI=Not Inspected

NP=Not Present

D= Deficiency

I	NI	NP	D
---	----	----	---

nor can the inspection anticipate future events or changes in performance due to changes in use or occupancy. It is recommended that you obtain as much information as is available about this property, including any seller's disclosures, previous inspection reports, engineering reports, building/remodeling permits, and reports performed for or by relocation companies, municipal inspection departments, lenders, insurers, and appraisers. You should also attempt to determine whether repairs, renovation, remodeling, additions, or other such activities have taken place at this property. It is not the inspector's responsibility to confirm that information obtained from these sources is complete or accurate or that this inspection is consistent with the opinions expressed in previous or future reports.

ITEMS IDENTIFIED IN THE REPORT DO NOT OBLIGATE ANY PARTY TO MAKE REPAIRS OR TAKE OTHER ACTIONS, NOR IS THE PURCHASER REQUIRED TO REQUEST THAT THE SELLER TAKE ANY ACTION. When a deficiency is reported, it is the client's responsibility to obtain further evaluations and/or cost estimates from qualified service professionals. Any such follow-up should take place prior to the expiration of any time limitations such as option periods. Evaluations by qualified tradesmen may lead to the discovery of additional deficiencies which may involve additional repair costs. Failure to address deficiencies or comments noted in this report may lead to further damage of the structure or systems and add to the original repair costs. The inspector is not required to provide follow-up services to verify that proper repairs have been made.

Property conditions change with time and use. For example, mechanical devices can fail at any time, plumbing gaskets and seals may crack if the appliance or plumbing fixture is not used often, roof leaks can occur at any time regardless of the apparent condition of the roof, and the performance of the structure and the systems may change due to changes in use or occupancy, effects of weather, etc. These changes or repairs made to the structure after the inspection may render information contained herein obsolete or invalid. This report is provided for the specific benefit of the client named above and is based on observations at the time of the inspection. If you did not hire the inspector yourself, reliance on this report may provide incomplete or outdated information. Repairs, professional opinions or additional inspection reports may affect the meaning of the information in this report. It is recommended that you hire a licensed inspector to perform an inspection to meet your specific needs and to provide you with current information concerning this property.

TEXAS REAL ESTATE CONSUMER NOTICE CONCERNING HAZARDS OR DEFICIENCIES

Each year, Texans sustain property damage and are injured by accidents in the home. While some accidents may not be avoidable, many other accidents, injuries, and deaths may be avoided through the identification and repair of certain hazardous conditions. Examples of such hazards include:

- malfunctioning, improperly installed, or missing ground fault circuit protection (GFCI) devices for electrical receptacles in garages, bathrooms, kitchens, and exterior areas;
- malfunctioning arc fault protection (AFCI) devices;
- ordinary glass in locations where modern construction techniques call for safety glass;
- malfunctioning or lack of fire safety features such as smoke alarms, fire-rated doors in certain locations, and functional emergency escape and rescue openings in bedrooms;
- malfunctioning carbon monoxide alarms;
- excessive spacing between balusters on stairways and porches;
- improperly installed appliances;
- improperly installed or defective safety devices;
- lack of electrical bonding and grounding; and
- lack of bonding on gas pipes, including corrugated stainless steel tubing (CSST).

To ensure that consumers are informed of hazards such as these, the Texas Real Estate Commission (TREC) has adopted Standards of Practice requiring licensed inspectors to report these conditions as "Deficient" when performing an inspection for a buyer or seller, if they can be reasonably determined.

I=Inspected

NI=Not Inspected

NP=Not Present

D= Deficiency

I	NI	NP	D
---	----	----	---

These conditions may not have violated building codes or common practices at the time of the construction of the home, or they may have been “grandfathered” because they were present prior to the adoption of codes prohibiting such conditions. While the TREC Standards of Practice do not require inspectors to perform a code compliance inspection, TREC considers the potential for injury or property loss from the hazards addressed in the Standards of Practice to be significant enough to warrant this notice.

Contract forms developed by TREC for use by its real estate licensees also inform the buyer of the right to have the home inspected and can provide an option clause permitting the buyer to terminate the contract within a specified time. Neither the Standards of Practice nor the TREC contract forms require a seller to remedy conditions revealed by an inspection. The decision to correct a hazard or any deficiency identified in an inspection report is left to the parties to the contract for the sale or purchase of the home.

INFORMATION INCLUDED UNDER “ADDITIONAL INFORMATION PROVIDED BY INSPECTOR”, OR PROVIDED AS AN ATTACHMENT WITH THE STANDARD FORM, IS NOT REQUIRED BY THE COMMISSION AND MAY CONTAIN CONTRACTUAL TERMS BETWEEN THE INSPECTOR AND YOU, AS THE CLIENT. THE COMMISSION DOES NOT REGULATE CONTRACTUAL TERMS BETWEEN PARTIES. IF YOU DO NOT UNDERSTAND THE EFFECT OF ANY CONTRACTUAL TERM CONTAINED IN THIS SECTION OR ANY ATTACHMENTS, CONSULT AN ATTORNEY.

ADDITIONAL INFORMATION PROVIDED BY INSPECTOR

I=Inspected

NI=Not Inspected

NP=Not Present

D= Deficiency

I	NI	NP	D
---	----	----	---



WILLCOX INSPECTIONS LLC™

Real Inspections. Sound Information.™
 1431 Wirt Road #163 Houston, Texas 77055
 713-461-0009

REAL ESTATE INSPECTION SERVICE AGREEMENT

THIS IS INTENDED TO BE A LEGALLY BINDING CONTRACT BETWEEN YOU, THE "CLIENT", AND WILLCOX INSPECTIONS LLC, THE "INSPECTOR", AND ALL SUBCONTRACTORS SCHEDULED OR ARRANGED THROUGH WILLCOX INSPECTIONS LLC

Subject Property 1505 Detering, Houston, TX Date: 8/17/16
 Client Name Joshua and Alexis FitzPatrick

PLEASE READ THIS AGREEMENT CAREFULLY BEFORE SIGNING

1. SCOPE OF THE INSPECTION

- A. A real estate inspection is a non-technically exhaustive, limited, general, non-invasive, visual survey and performance evaluation of a building performed using normal controls and does not require the use of specialized equipment or procedures. The inspection will be performed in a manner consistent with the Section 535.220 and Sections 535.227 through 535.233 of the rules of the Texas Real Estate Commission. (A copy of these Sections of the rules of the Texas Real Estate Commission are readily available at www.willcoxinspections.com.) The inspection does not include any destructive testing or dismantling of equipment, components or systems. In the event that the property is a part of a condominium unit, the inspection will not include any other connected or external portions of a multi-unit building or any common areas covered by a joint use agreement or considered common areas.
- B. In exchange for the inspection fee paid by the Client, the Inspector agrees to provide the Client(s) with a report of the Inspector's written opinion as to the apparent general condition of the structure(s), parts, components and systems at the time of the inspection. The Inspector will prepare a written report of the Inspector's professional **opinions** of the apparent condition of the readily accessible systems and components of the building. The Client recognizes and acknowledges that all items cannot be found or discovered during a limited, visual inspection of the property and that such an expectation would be considered unreasonable on the part of the Client.
 - 1. The Inspectors report may indicate one or more of the following options:
 - a. The part, component or system is performing in a manner consistent with recognized industry association standards (not common practice for the area), that the part component or system achieves an anticipated operation, function or configuration relative to its age and normal wear and tear from ordinary use with recognition of recognized industry standards in place at the time of construction;
 - b. That, in the Inspector's professional **opinion**, a part component or system is in need of repair, replacement or maintenance; or
 - c. Further evaluation by a competent, licensed or registered professional or tradesman.
- C. The inspection is limited to only those systems and components that are "accessible", can be easily reached, entered, or viewed without difficulty, danger, moving of obstructions, or requiring any action which may result in damage to the property or personal injury to the Inspector as set out in the inspection report. The inspector will not climb over obstacles, move furnishings or large, heavy or covered items, remove wall, ceiling or floor coverings or any other obstruction of any type to inspect any part, component or system. Latent and concealed defects and deficiencies are excluded from the inspection and the Inspector is not liable for latent and concealed defects and deficiencies.

2. CLIENT'S DUTY

Client agrees to read the entire report when it is received and promptly call the Inspector with any question or concerns regarding the inspection or written report. The written report shall represent the sole, final and exclusive **opinions** of the Inspector. In the event client becomes aware of a reportable condition which was not reported by the Inspector, Client agrees to promptly notify Inspector and allow Inspector and/or Inspector's designated representative(s) to inspect said condition(s) before making any repair, alteration, or replacement. If the reportable condition has been altered in any way the Client's right to make a claim against the Inspector is waived.

3. FURTHER EVALUATION

I=Inspected

NI=Not Inspected

NP=Not Present

D= Deficiency

I	NI	NP	D
---	----	----	---

Client acknowledges and agrees that the Inspector is a generalist and that further investigation of a reported condition by an appropriate certified, competent, registered, or licensed specialist may, and likely will, provide additional information that may affect Client(s) decision to purchase the house. Client should seek further evaluation from certified, competent, registered, or licensed professionals or tradesmen regarding the deficiencies identified in the written report. Inspector is not liable for Client(s) failure to further investigate reported deficiencies.

4. CHANGE IN CONDITION(S)

The parties agree and understand that conditions of systems and components may change through vacancy or change in ownership, the removal/replacement of furniture, furnishing or equipment or from weather conditions between the inspection date and the time of closing (settlement). Client acknowledges that Inspector does not take care, custody or control of the structure at any time and that Inspector is not responsible for the maintenance or servicing of any part, component or system of the structure.

5. LIMITATIONS OF A VISUAL INSPECTION

The parties agree and understand the Inspector is not an insurer or guarantor against defects in the structure, its parts, components, or systems. Client(s) understand that the inspection and inspection report does not constitute a guarantee or warranty of insurability, operability, longevity, merchantability or fitness for a particular purpose, expressed or implied, nor is it a substitute for real estate transfer disclosures which may be required by law or custom. INSPECTOR MAKES NO WARRANTY, EXPRESS OR IMPLIED, AS TO THE PRESENT OR FUTURE FITNESS FOR USE, CONDITION, INSURABILITY, PERFORMANCE OR ADEQUACY OF ANY INSPECTED STRUCTURE, PART, COMPONENT, OR SYSTEM, THE PRESENCE OR ABSENCE OF LATENT, COVERED OR CONCEALED DEFECTS DURING THE INSPECTION, OR THE REMAINING USEFUL LIFE OF ANY SYSTEM, PART OR COMPONENT OF THE PROPERTY. The Inspection will not include an appraisal of the value, a boundary survey or flood plain assessment of structure and/or property lines, easements or underground structures. This inspection and the inspection report are NOT a code compliance inspection or certification for past or present governmental codes or regulations. The inspection and the inspection report do not determine whether the property is or is not insurable. Compliance with electrical codes or standards and/or adequacy of wiring and circuitry is beyond the scope of this inspection and report and is specifically excluded. If more in-depth information is desired or required on the electrical system or systems, it is recommended that a qualified electrician be consulted. This inspection is not intended to be an exhaustive evaluation of all the systems and appliances in the structure, nor is it intended to be a total list of defects, existing or potential. The inspection report is not a repair list. If the professional or technician hired to perform repairs to this structure did not find more issues than those discovered during the inspection you are advised that the repair person was likely not thorough in making repairs.

6. LIMITATION OF LIABILITY

In recognition that the inspection performed is of a limited nature and that the Inspector cannot remove wall, ceiling or floor coverings, that the Inspector is greatly hampered in his ability to see defects that are covered, concealed, inaccessible or dangerous and that the inspection was performed for a nominal fee in recognition of these limitations, the Client agrees that any claim for any reason against WILLCOX INSPECTIONS LLC and its agents' liability, if any, shall be limited to the amount of the inspection fee paid for this inspection by the Client. This limitation shall apply regardless of the cause of action or the legal theory pled or asserted specifically including, but not limited to, negligence.

7. THIRD PARTIES AND SUBROGATION

The inspection and written report are performed and prepared for the sole and exclusive use and possession of the Client. No other person or entity may rely on the report issued pursuant to this Agreement under any condition or theory of claim. In the event that any person or entity, not a party to this Agreement, makes any claim against the Inspector, its employees or agents, arising out of the services performed by the Inspector under this Agreement, or claims alleging in whole or part any negligent act or omission of the Inspector, the Client agrees to indemnify, defend, and hold harmless Inspector from any and all damages, expenses, costs, and attorney fees, arising from such a claim.

8. DISPUTES AND ARBITRATION

In the event a dispute arises regarding an inspection that has been performed under this service agreement, Client(s) agree to provide WILLCOX INSPECTIONS LLC a reasonable opportunity to re-inspect the property and resolved any dispute amicably. Upon the request of either party, subject to the Limitation of Liability clause of this contract, all unresolved disputes relating to this agreement shall be submitted for arbitration in accordance with (AAA) American Association of

I=Inspected

NI=Not Inspected

NP=Not Present

D= Deficiency

I	NI	NP	D
---	----	----	---

Arbitrators and pursuant to the Federal Arbitration Act then in effect with costs shared equally. This provision shall be specifically enforceable and damages for breach of this provision shall include but not be limited to court costs and attorney's fees.

9. SEVERABILITY

If any court of competent jurisdiction determines that any section, provision or part of this Agreement is void, unenforceable, or contrary to Texas law, the remaining sections of this Agreement shall remain in full force and effect.

10. RIGHT OF PUBLICATION

Possession of this report does not carry with it the right of publication. This inspection report may not be used for any purpose or by any person other than the party to whom it is addressed without the written consent of the inspector. None of the contents of this inspection report, parts or components of this report or a copy of this report shall be conveyed to the public through any means, purpose or venue without the written consent and approval of the inspector. Parts of the report may be protected by Federal copyrights.

11. LIMITATION AND EXCLUSION CLAUSE

The Client expressly acknowledges and agrees that the following are not included in the scope of the inspection and the inspection report and further acknowledges that the Inspector makes no representations or warranties as to these parts, components or systems. THE FOLLOWING SYSTEMS, ITEMS, AND CONDITIONS WHICH ARE NOT WITHIN THE SCOPE OF THE BUILDING INSPECTION INCLUDE BUT ARE NOT LIMITED TO:

- 1) boring, digging or probing the soil or structure
- 2) location or effects of geological faults or of any underground structure or object
- 3) any part, component or system concealed by wall coverings, furniture, fixtures, ceiling coverings or floor coverings,
- 4) location of gas lines and/or systems
- 5) presence of asbestos and/or radon gas
- 6) CSST (Corrugated Stainless Steel Tubing) gas pipes and bonding of CSST
- 7) lead based paint and/or products made from or containing lead
- 8) tainted or Chinese drywall
- 9) adequacy of site drainage
- 10) opinions relating to compliance with any specifications, legal and/or code requirements or restrictions of any kind, and
- 11) determination of the presence or health effects of molds, mildew, allergen, carcinogen or pathogen, etc.

The following items are beyond the scope of this inspection and will not be inspected unless otherwise specifically stated in this report: Underground items (such as utilities), gas lines, sewer or drain systems, fuel quality, environmental items (such as fuel tanks), telephone systems, television and/ or satellite systems, elevators, central vacuum systems, detached structures, bulkheads / docks and piers, fences / yard enclosures; underwater electrical equipment, circuits or components; intercoms, sound systems, security and fire and/or smoke detection systems, fire sprinkler systems, water-conditioning equipment, drain or waste ejector pumps, water mains, sewer systems, water wells / springs, lawn sprinkler systems, swimming pools, spas, hot tubs, saunas, steam baths, fountains, waterfront structures and equipment, solar systems, outdoor cooking equipment, free-standing appliances, playground equipment, or personal property.

No environmental inspections of any kind were performed during this inspection. Even if comments are made regarding certain aspects or issues, inspections and/or any determination of the presence or possible dangers of materials organisms or microbial organisms including, but not limited to Chinese drywall, asbestos, lead, formaldehyde, mildew, molds, fungi, etc. are specifically excluded from the inspection and from this report. No intrusive tests or methods damaging to sound materials were employed. No indoor air quality test was performed. If you have any concerns over the presence or possible future growth of any of these type items, you should, as part of your due diligence, have the environmental inspections of your choice performed on the house prior to closing.

12. PERSONAL SAFETY

We are not responsible for another participant's personal safety during the inspection process. Client, their representative's, or others participation shall be at his/her own risk for falls, injuries, property damage, etc. We reserve the right to refuse service to anyone for any reason.

13. TOTAL AGREEMENT

I=Inspected

NI=Not Inspected

NP=Not Present

D= Deficiency

I NI NP D

This Agreement, including the terms and conditions on all pages, represents the entire agreement between the parties and there are no other agreements either written or oral between them. This Agreement shall be amended only by written agreement signed by both parties.

14. ACKNOWLEDGMENT

The undersigned has reviewed this document, understands its content and agrees to the terms and conditions contained. The client further represents and warrants that he or she has full and complete authority to execute this contract on behalf of any spouse or significant other or any other person with claim to title or occupancy and to fully bind any spouse or significant other or any other person with claim to title or occupancy to all terms, conditions, exclusions and limitations of this agreement. The report adheres to the "TREC Texas Real Estate Commission "Standards of Practice" which is readily available at <http://www.trec.state.tx.us>.

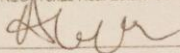

Client

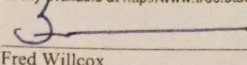
 for Fred Willcox

Fred Willcox
President
Willcox Inspections LLC

Client

08/17/16

Date

If after walking thru the property with the inspector, if you are in anyway dissatisfied with the services provided by Willcox Inspections LLC you are under no obligation to pay the inspection fee. No written report will be provided unless and until the inspection fee is paid.

I=Inspected

NI=Not Inspected

NP=Not Present

D= Deficiency

I	NI	NP	D
---	----	----	---

Additional pages may be attached to this report. Read all pages of this inspection report very carefully. This report may not be complete without the attachments. If an item is present in the property but is not inspected, the “NI” column will be checked and an explanation is necessary. The inspector may provide comments whether or not an item is deemed in need of repair.

REFERENCES TO THE BUILDING CODES ARE IN ITALICS AND UNDERLINED TEXT AND ARE USED SOLELY FOR CLARIFICATION OF THE ITEM NOTED. THE QUOTATIONS FROM THE BUILDING CODE ARE FROM THE INTERNATIONAL BUILDING CODE PUBLISHED BY AND COURTESY OF THE INTERNATIONAL CODE COUNCIL, INC. UNLESS OTHERWISE NOTED. IT SHOULD BE UNDERSTOOD THAT OLDER HOMES WILL NOT MEET CURRENT CODES AND THAT THESE HOUSES WERE NOT CONSTRUCTED TO ANTICIPATE FUTURE CODES, REQUIREMENTS OR THE CREATION OF NEW LIFE/SAFETY DEVICES OR EQUIPMENT. NOTATIONS OF CURRENT CODE REQUIREMENTS AND OF MODERN LIFE/SAFETY EQUIPMENT ARE MADE TO ADVISE YOU THAT THESE CONDITONS, APPLIANCES AND DEVICES EXIST AND THAT YOU MAY WISH TO UPGRADE THE HOUSE TO A LEVEL OF SAFETY THAT SATISFIES YOU.

HOW TO READ THIS REPORT

DEFICIENCIES: These are items that are not functioning properly, were improperly installed, and are considered to be unsafe or items that are functionally obsolescent. If you understand the comment in bold you do not need to read the information section that follows.

INFORMATION: The information section explains the deficiency noted in the part, component or system. This information is provided to give you a clearer understanding of the defect noted.

REFERENCES: References are the materials I use to provide the basis of calling out a deficiency. Reference materials are from the model building codes, manufacturer’s installation instructions or from trade association manuals. The model building codes require that the minimum standards of the building code or the manufacturer’s installation instructions, whichever is more restrictive, be used on every part, component and system in the structure. If the seller or the builder wishes to dispute an item in this report, the seller or builder should provide you with the source material they are relying on to refute the statement in this report. Common building practices or the “everybody does it” defense is not recognized as compliance with any model building code or manufacturer’s installation instruction.

NOTE OR NOTICE: Information provided on things that you should know about the structure or a part component or system. Notes or Notices are not indications of a defect or deficiency.

PHOTOGRAPHS: Photographs are used to show you an example of the deficiency noted in the report. The photographs DO NOT show all defects or locations of the noted deficiency in most cases. If you opted against having photographs included in your inspection report, I still took photograph of the house and the photographs are retained with the field notes of your inspection.

I. STRUCTURAL SYSTEMS

The subject structure was a four story, single family dwelling supported on what appeared to be a slab-on-grade foundation. The exterior veneers were stucco, wood, and wood fiber products siding. The roof was covered with composition shingles and metal materials. The house was in the final stages of construction and had been professional staged for showing. For the purposes of this report the house will be considered to be facing East. The weather was partly cloudy with intermittent heavy rain at the time of the inspection.

I=Inspected

NI=Not Inspected

NP=Not Present

D= Deficiency

I	NI	NP	D
---	----	----	---

NOTICE: The house was not ready for a full inspection. An inspection of the major structural components was made. The inspection and this report are specifically limited to those items noted as deficient or in need of repair in this report. No other part, component or system should be considered to have been inspected. Once all of the appliances are installed and all appliances and systems are in service, a full inspection can be performed and a final report can be issued.

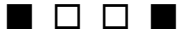

A. Foundations

Type of Foundation(s):

What appeared to be a concrete slab-on-grade foundation

Comments:

Items noted during the visual inspection that were deemed deficient, are in need of repair, adjustment, restoration, that require comment, continuation of the due diligence process and/or servicing or items noted for information include but are not limited to:

Information: The foundation appeared to be performing without the obvious need of immediate remedial leveling at the time of the inspection, in my opinion.

Deficiency: Form boards and/or wooden stakes used to support the form boards remained on the property.

Information: All wooden materials should be removed from the area around the foundation to reduce the chances of infestation by wood destroying organisms.

I=Inspected

NI=Not Inspected

NP=Not Present

D= Deficiency

I	NI	NP	D
---	----	----	---

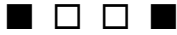

B. Grading & Drainage

Comments:

Items noted during the visual inspection that were deemed deficient, are in need of repair, adjustment, restoration, that require comment, continuation of the due diligence process and/or servicing or items noted for information include but are not limited to:

Deficiency: The surrounding soils were in contact with or were too close to the exterior finishes of the structures in some areas.

Information: The soil should be lowered to provide a clearance of four inches between the surface of the soil and the lower edge of the exterior veneer if the veneer is masonry and six inches if the veneer is other than masonry per Section R404.1.6 of the IRC. Soil in contact with the veneer allows easy access to the wall cavity and framing to insects. This situation also allows moisture to penetrate into the framing and interior wall coverings and floor coverings. The soil should be graded to prevent water from standing next to the foundation.

References: 404.1.6 Height above finished grade.

Concrete and masonry foundation walls shall extend above the finished grade adjacent to the foundation at all points a minimum of 4 inches (102 mm) where masonry veneer is used and a minimum of 6 inches (152 mm) elsewhere.

The minimum distance above adjacent grade to which the foundation must be extended provides termite protection and minimizes the chance of decay resulting from moisture migrating to the wood framing. A reduced foundation extension is permitted when masonry veneer is used. From the Commentary to the IRC.

Deficiency: There were depressions adjacent to the foundation capable of holding water. This was particularly observed on the right side and rear of the house.

Information: The yards should be filled and graded to drain water away from the foundation and to prevent water from standing in the yards. Section R401.3 of the IRC (International Residential Code) requires that the grade away from the foundation walls shall be graded to drain water away from the foundation and that the grade shall fall a minimum of 6 inches in the first ten feet. Depressions in the yards are also trip hazards. The depressions should be removed for safety.

References: 401.3 Drainage.

Surface drainage shall be diverted to a storm sewer conveyance or other approved point of collection so as to not create a hazard. Lots shall be graded so as to drain surface water away from foundation walls. The grade away from foundation walls shall fall a minimum of 6 inches (152 mm) within the first 10 feet (3048 mm).

Deficiency: Portions of the gutter system terminated onto balcony materials.

Information: Downspouts should direct water off the balcony, not directly onto the balcony materials.

Deficiency: Erosion of the soil was occurring at some of the gutter downspout terminations.

Information: The holes caused by the erosion should be filled. Splash blocks should be installed at the gutter downspout terminations to reduce the velocity of the water discharged from the downspout and to reduce the erosion of the soil.

NOTICE: There were openings for underground drains adjacent to the structure or in the yards.

I=Inspected

NI=Not Inspected

NP=Not Present

D= Deficiency

I	NI	NP	D
---	----	----	---

Information: The underground drains were not tested and are specifically excluded from the report. It is important that you keep the strainers cleared of debris. Debris blocking the strainers can cause or contribute to water penetrating into the structure(s).

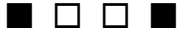

C. Roof Covering Materials

Type(s) of Roof Covering: Composition Shingle and Metal

Viewed From: ground with binoculars and the 4th floor balcony due to Height and Weather Conditions as described in this report

Comments:

Items noted during the visual inspection that were deemed deficient, are in need of repair, adjustment, restoration, that require comment, continuation of the due diligence process and/or servicing or items noted for information include but are not limited to:

NOTE: The surface of a roof begins to deteriorate as soon as it is placed into service and exposed to the elements. The degree of deterioration accelerates with the age of the roof and cannot be determined accurately by a visual inspection. Roof leaks can and may occur at any time, regardless of the age of the roof, and cannot be accurately predicted. If roof leaks do occur, their presence does not necessarily indicate the need for total replacement of the roof coverings. Responsibility for future performance of the roof is specifically excluded from this report.

NOTICE: The surface of the roof was not accessible to this inspector and was viewed from the ground with binoculars and from the 4th floor balcony accessed through the exterior door. An inspection of the roof covering materials from these locations is not an effective inspection. A competent roofer with the equipment capable of safely reaching and staying on the roof should be engaged to perform a proper inspection of the surface of the roof covering materials prior to the expiration of any contractual time limitations on due diligence inspections or investigations.

NOTICE: The roof deck was treated with a radiant barrier. Aluminum based radiant barriers are alleged to cause greater damage to a structure when a house is struck by lightning. A class action lawsuit has been recently filed regarding this issue. You are advised that, while radiant barriers are highly effective, in my experience, in lowering the temperature of an attic, there appears to be a risk that having a radiant barrier may cause damage to your home and to those who occupy the home. You may wish to have the radiant barrier material removed.

Deficiency: Proper flashing materials were not observed in all locations where required.

Deficiency: Loose flashing materials were noted on the drip edges of the roof, etc.

Information: Properly installed flashing materials reduce the chances of water penetration and damage to the roof covering materials.

Deficiency: Dripping rain water was observed in the attic at sewer vent pipe penetrations near the HVAC equipment.

Information: The roof jacks should be repaired or replaced to prevent interior water penetration.

Deficiency: Dripping rain water was observed in the attic at gas furnace flue piping penetration.

Information: The roof jacks should be repaired or replaced to prevent interior water penetration.

Deficiency: Portions of the roof were inadequately sloped for the use of composition shingles.

I=Inspected

NI=Not Inspected

NP=Not Present

D= Deficiency

I	NI	NP	D
---	----	----	---



Information: Composition shingles are not currently manufactured for use on roofs with a slope of less than a three inch rise in a twelve inch run. Composition shingles can be used on a roof with a two inch rise in a twelve inch run provided that thirty pound felt is installed under the shingles. Under no condition can composition shingles be used on a roof with a slope of less than three in twelve. It appeared as though composition shingle application on portions of the roof are incorrect and the shingles should be replaced with proper roofing materials designed for low sloped roofs. This does not mean that these areas of the roof are currently leaking or that they may develop leaks in the near future. This is to advise you that the roof covering materials are being improperly used.

Deficiency: Damaged shingles were noted on the roof deck. All damaged shingles on the roof deck should be replaced.

Deficiency: The PVC sewer vent pipes above the surface of the roof had not been painted.

I=Inspected

NI=Not Inspected

NP=Not Present

D= Deficiency

I	NI	NP	D
---	----	----	---



Information: The PVC pipes must be painted to protect the PVC from degradation by the ultra violet rays of the sun. The lack of protection from the ultra violet rays of the sun can cause the PVC pipes to crack and break.

Deficiency: There were no parapet caps on top of the wood fiber products walls.

Information: All masonry materials absorb water. The tops of all masonry walls that are exposed to the elements are required to be covered with a water proof material. Parapet caps should be installed to prevent water penetration. Wood fiber products materials are not manufactured for use horizontally. The wood fiber products material should be replaced with materials approved for horizontal installation. Proper parapet caps should be installed to reduce the chances of water penetration.

Reference: *Courtesy of James Hardie, Inc.*

I=Inspected NI=Not Inspected NP=Not Present D= Deficiency

I	NI	NP	D
---	----	----	---

IMPORTANT: FAILURE TO INSTALL AND FINISH THIS PRODUCT IN ACCORDANCE WITH APPLICABLE BUILDING CODES AND JAMES HARDIE WRITTEN APPLICATION INSTRUCTIONS MAY LEAD TO PERSONAL INJURY, AFFECT SYSTEM PERFORMANCE, VIOLATE LOCAL BUILDING CODES, AND VOID THE PRODUCT ONLY WARRANTY. BEFORE INSTALLATION, CONFIRM THAT YOU ARE USING THE CORRECT HARDIEZONE™ PRODUCT INSTRUCTIONS. INSTALLATION OF HZ10® PRODUCTS OUTSIDE AN HZ10® LOCATION WILL VOID YOUR WARRANTY. TO DETERMINE WHICH HARDIEZONE™ APPLIES TO YOUR LOCATION, VISIT WWW.HARDIEZONE.COM OR CALL 1-866-942-7343 (866 9HARDIE)

<p>STORAGE & HANDLING:</p> <p>Store flat and keep dry and covered prior to installation. Installing siding wet or saturated may result in shrinkage at butt joints. Carry planks on edge. Protect edges and corners from breakage. James Hardie is not responsible for damage caused by improper storage and handling of the product.</p> 	<p>CUTTING INSTRUCTIONS</p> <p style="text-align: center;">▲</p>	<p>OUTDOORS</p> <ol style="list-style-type: none"> Position cutting station so that wind will blow dust away from user and others in working area. Use one of the following methods: <ol style="list-style-type: none"> Best: <ol style="list-style-type: none"> Score and snap Shears (manual, electric or pneumatic) Better: <ol style="list-style-type: none"> Dust reducing circular saw equipped with a HardieBlade® saw blade and HEPA vacuum extraction Good: <ol style="list-style-type: none"> Dust reducing circular saw with a HardieBlade saw blade (only use for low to moderate cutting) <p><small>Important Note: For maximum protection (lowest respirable dust production), James Hardie recommends always using "Best"-level cutting methods where feasible.</small></p> <p><small>NIOSH-approved respirators can be used in conjunction with above cutting practices to further reduce dust exposures. Additional exposure information is available at www.jameshardie.com to help you determine the most appropriate cutting method for your job requirements. If concern still exists about exposure levels or you do not comply with the above practices, you should always consult a qualified industrial hygienist or contact James Hardie for further information.</small></p> <p style="text-align: right;"><small>SD083105</small></p>
<p>INDOORS</p> <ol style="list-style-type: none"> Cut only using score and snap, or shears (manual, electric or pneumatic). Position cutting station in well-ventilated area. <p>- NEVER use a power saw indoors - NEVER use a circular saw blade that does not carry the HardieBlade saw blade trademark - NEVER dry sweep – Use wet suppression or HEPA Vacuum</p>		

GENERAL REQUIREMENTS:

- HardiePlank® lap siding can be installed over braced wood or steel studs spaced a maximum of 24" o.c. or directly to minimum 7/16" thick OSB sheathing. See general fastening requirements. Irregularities in framing and sheathing can mirror through the finished application.
- Information on installing James Hardie products over foam can be located in **JH Tech Bulletin 19** at www.jamehardie.com
- A water-resistive barrier is required in accordance with local building code requirements. The water-resistive barrier must be appropriately installed with penetration and junction flashing in accordance with local building code requirements. James Hardie will assume no responsibility for water infiltration. James Hardie does manufacture HardieWrap® Weather Barrier, a non-woven non-perforated housewrap¹, which complies with building code requirements.
- When installing James Hardie products all clearance details in figs. 3-14 must be followed.
- Adjacent finished grade must slope away from the building in accordance with local building codes - typically a minimum of 6" in the first 10'.
- Do not use HardiePlank lap siding in fascia or trim applications.
- Do not install James Hardie products, such that they may remain in contact with standing water.



Deficiency: Exposed fasteners were noted in several areas of the roof's surface.

Information: The heads of the nails will rust and deteriorate, leaving openings through the roof covering material. The exposed fasteners should be covered and sealed.

Deficiency: Some of the downspouts on the guttering system were not connected or were loose.



Information: The gutter system should be connected should be properly secured to the structure.

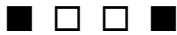

D. Roof Structure & Attic

Viewed From: the Interior of the Attic
Approximate Average Depth of Insulation: 11"
Comments:

Items noted during the visual inspection that were deemed deficient, are in need of repair, adjustment, restoration, that require comment, continuation of the due diligence process and/or servicing or items noted

I=Inspected

NI=Not Inspected

NP=Not Present

D= Deficiency

I	NI	NP	D
---	----	----	---

for information include but are not limited to:

Walkways in the attic were limited to the areas of the HVAC equipment and the water heater. Much of the attic area could not be safely accessed. The areas of the attic without walkways were not inspected except by the use of a flashlight. Information.

Notice: Safety precautions should be taken to prevent child access to the attic area(s) and/or to any other unfinished area of the house.

Information: Access openings to the attic areas or any unfinished areas should be made inaccessible by the use of locks that are not operable by a child and/or by latches that are not accessible to and that cannot be operated by a child. Such locking devices should be installed before the child learns to crawl and, preferably, before you occupy the house.

Information: There were no visible defects noted in the accessible attic framing that appeared to require immediate repair at the time of the inspection, in my opinion.

Notice: This inspection does not address any windstorm requirements, if applicable to the area.

Deficiency: The sewer vent pipe penetrations of the roof deck appeared to be sealed with neoprene roof jacks. Water from rains was observed running down the pipe at some penetrations.



Information: These jacks should be repaired or replaced.

Deficiency: The electrical conductors and the lighting fixture under the staircase break the required fire protection of the staircase.

I=Inspected

NI=Not Inspected

NP=Not Present

D= Deficiency

I	NI	NP	D
---	----	----	---



Information: Staircases are required to be fireblocked on the underside of the staircase and at the top and bottom of each flight. Fireblocking is required in these areas to slow the speed of a fire and to keep the staircase standing and usable for as long as possible in the event of a fire. This requirement is made to give the people in the upper stories of the house a chance to escape. Proper firestopping should be provided for safety.

References: R302.11 Fireblocking and R302.7 Under-stair protection.

In combustibile construction, fireblocking shall be provided to cut off all concealed draft openings (both vertical and horizontal) and to form an effective fire barrier between stories, and between a top story and the roof space.

Fireblocking shall be provided in wood-frame construction in the following locations:

1. In concealed spaces of stud walls and partitions, including furred spaces and parallel rows of studs or staggered studs, as follows:

1.1. Vertically at the ceiling and floor levels.

1.2. Horizontally at intervals not exceeding 10 feet (3048 mm).

2. At all interconnections between concealed vertical and horizontal spaces such as occur at soffits, drop ceilings and cove ceilings.

3. In concealed spaces between stair stringers at the top and bottom of the run. Enclosed spaces under stairs shall comply with Section R302.7.

4. At openings around vents, pipes, ducts, cables and wires at ceiling and floor level, with an approved material to resist the free passage of flame and products of combustion. The material filling this annular space shall not be required to meet the ASTM E 136 requirements.

5. For the fireblocking of chimneys and fireplaces, see Section R1003.19.

6. Fireblocking of cornices of a two-family dwelling is required at the line of dwelling unit separation.

To restrict the movement of flame and gasses to other areas of a building through concealed passages in building components such as floors, walls and stairs, fireblocking of these concealed combustibile spaces is required to form a barrier between stories and between a top story and the roof space. From the Commentary to the IRC.

R302.7 Under-stair protection.

Enclosed accessible space under stairs shall have walls, under-stair surface and any soffits protected on the enclosed side with 1/2-inch (12.7 mm) gypsum board.

I=Inspected

NI=Not Inspected

NP=Not Present

D= Deficiency

I	NI	NP	D
---	----	----	---

Often times the space under a stairway is used for storage, since this space is often of little use for other purposes. The code permits the use of an open space beneath a stair without the need for any additional protection. Additionally, if the space is walled off and there is no access to the area, then the code is also not concerned. If, however, the area beneath the stairway is enclosed and any type of access is provided into the space, then the walls, soffits and ceilings of the enclosed space must be protected on the enclosed side with at least 1/2-inch (12.7 mm) gypsum board. From the Commentary to the IRC.

R602.8.1.2 Fireblocking integrity.

The integrity of all fireblocks shall be maintained.

Piping, ducts, or other similar items that pass through firestops must be installed so that the integrity of the firestop is maintained. This may be accomplished by packing an oversized hole with an acceptable fireblocking material. From the commentary to the IRC.

Deficiency: The attic was inadequately ventilated.

Information: While the ventilation of the attic may meet the requirements of the IRC, the IRC is intended to be a worldwide code. Its provisions may not be adequate or reasonable for certain areas of the globe. The IRC in no way limits a builder from exceeding the minimum requirements of the code in order to provide a better product for the consumer. Additional ventilation should be installed in my opinion.

Deficiency: The wall junctions and penetrations were not sealed in accordance with the International Energy Code, Section 502.1.4.2 and Section N1102.1.10 of the International Residential Code, as required by the State of Texas.

Information: If the house is not properly insulated and sealed, your air conditioning system may not function properly. This can lead to higher relative humidity levels in the house, poor air distribution and to increased utility expenses as the systems have to operate longer to lower internal temperatures.

References: N1102.1.10 Air leakage.

All joints, seams, penetrations; site-built windows, doors, and skylights; openings between window and door assemblies and their respective jambs and framing; and other sources of air leakage (infiltration and exfiltration) through the building thermal envelope shall be caulked, gasketed, weather-stripped, wrapped, or otherwise sealed to limit uncontrolled air movement.

I=Inspected

NI=Not Inspected

NP=Not Present

D= Deficiency

I	NI	NP	D
---	----	----	---

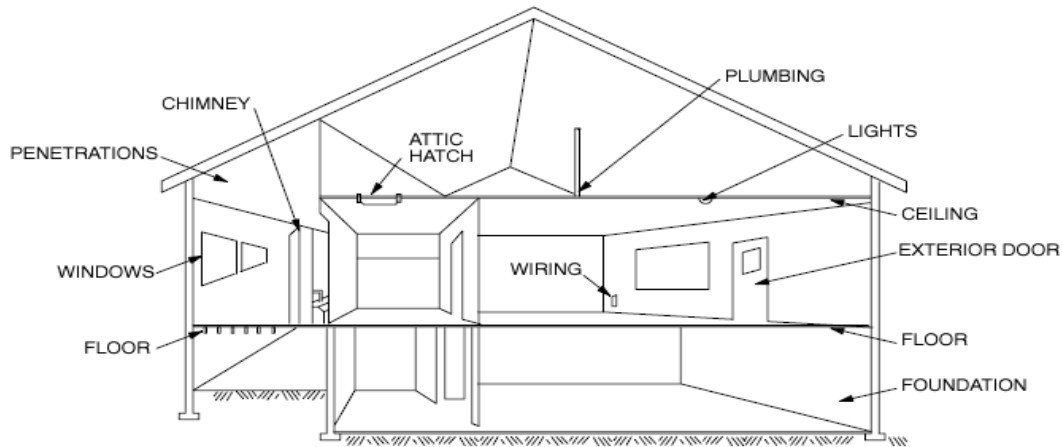

Figure N1102.1.10
TYPICAL SOURCES OF AIR LEAKAGE IN THE HOME

■ □ □ ■ E. Walls (Interior & Exterior)

Comments:

Items noted during the visual inspection that were deemed deficient, are in need of repair, adjustment, restoration, that require comment, continuation of the due diligence process and/or servicing or items noted for information include but are not limited to:

Notice: Structural components concealed behind finished surfaces could not be inspected and only a representative sampling of visible structural components was inspected. Observations of surface coatings (such as paint, applied stain, etc.) are cosmetic observations, and are specifically excluded from this inspection. Assessing the quality and condition of finishes, particularly interior, is highly subjective. Issues such as cleanliness, cosmetic flaws, quality of materials, architectural appeal and color were outside the scope of this inspection.

Deficiency: The exterior frame windows, door and other wall penetrations installed through the wood and wood fiber products siding were not properly flashed.

I=Inspected

NI=Not Inspected

NP=Not Present

D= Deficiency

I	NI	NP	D
---	----	----	---



Information: Metal flashing, called “Z” flashing, should have been installed during construction of the structure. Z flashing is cut into the frame siding and covers the top piece of trim to prevent water from entering the trim or window frame. Z flashing is meant to prevent water penetration, not to act as a drain after water penetration has occurred. Proper Z flashing materials should be installed to prevent water penetration.

References: 703.8 Flashing and Typical Manufacturer’s Installation Instructions.

Approved corrosion-resistive flashing shall be provided in the exterior wall envelope in such a manner as to prevent entry of water into the wall cavity or penetration of water to the building structural framing components. The flashing shall extend to the surface of the exterior wall finish and shall be installed to prevent water from reentering the exterior wall envelope. Approved corrosion-resistant flashings shall be installed at all of the following locations:

I=Inspected

NI=Not Inspected

NP=Not Present

D= Deficiency

I	NI	NP	D
---	----	----	---

1. At top of all exterior window and door openings in such a manner as to be leakproof, except that self-flashing windows having a continuous lap of not less than 1/8 inches (28 mm) over the sheathing material around the perimeter of the opening, including corners, do not require additional flashing; jamb flashing may also be omitted when specifically approved by the building official.
2. At the intersection of chimneys or other masonry construction with frame or stucco walls, with projecting lips on both sides under stucco copings.
3. Under and at the ends of masonry, wood or metal copings and sills.
4. Continuously above all projecting wood trim.
5. Where exterior porches, decks or stairs attach to a wall or floor assembly of wood-frame construction.
6. At wall and roof intersections.
7. At built-in gutters.

The code requires that all points subject to the entry of moisture be appropriately flashed. Roof and wall intersections and parapets create significant challenges, as do exterior wall openings exposed to the weather. Where wind-driven rain is expected, the concerns are even greater. While the code identifies a number of locations where flashing is specifically required, the entire exterior envelope must be weather-tight to protect the interior from weather. Therefore, any location on the exterior envelope that provides a route for the admission of water or moisture into the building must be properly protected. From the commentary to the IRC.

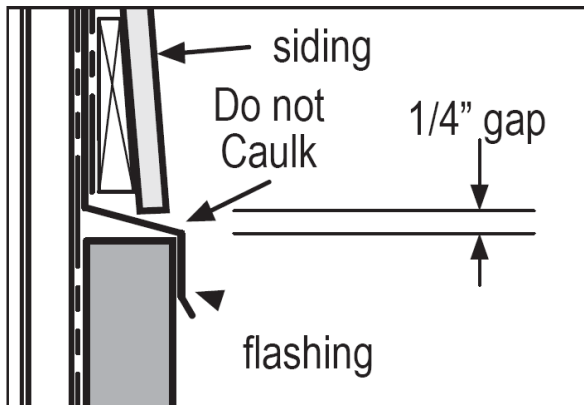

Courtesy of James Hardie Products, Inc.

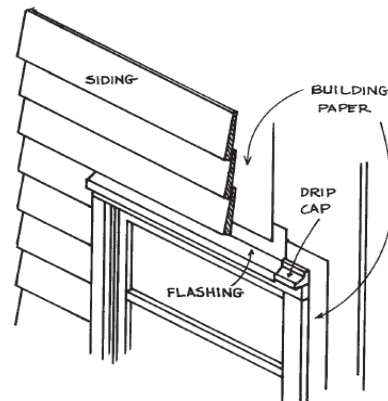

Courtesy American Plywood Association, Inc.

SIDING TO FLASHING CLEARANCE

A 1/4-in. clearance must be maintained between James Hardie® siding and trim products and any horizontal flashing.

All horizontal flashing should be installed with a positive slope in such a way that it promotes proper drainage and does not allow moisture to pool on top of the flashing.

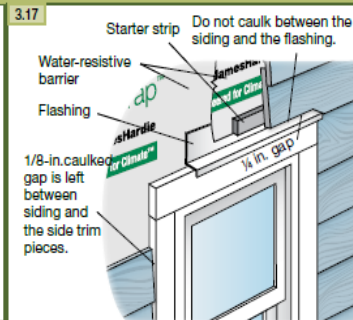
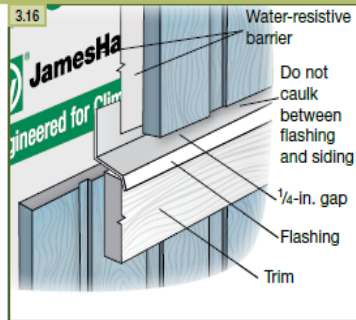

Courtesy of James Hardie Products, Inc.

I=Inspected

NI=Not Inspected

NP=Not Present

D= Deficiency

I	NI	NP	D
---	----	----	---

Deficiency: All penetrations through the cladding materials had not been sealed or flashed.

Information: Any and all penetrations are required to be sealed and/or flashed in such a manner as to prevent water penetration through the cladding materials. All wall penetrations should be properly flashed and sealed.

References: *R703.7.5 Flashing, R703.7.6 Weepholes, and R703.8 Flashing and Typical Manufacturer's Installation Instructions (information from James Hardie Products, Inc. is used as Hardie produces the clearest examples for flashing and drainages and Hardie siding materials are considered to be a masonry product.*

R703.7.5 Flashing.

Flashing shall be located beneath the first course of masonry above finished ground level above the foundation wall or slab and at other points of support, including structural floors, shelf angles and lintels when masonry veneers are designed in accordance with Section R703.7. See Section R703.8 for additional requirements.

Flashing is necessary to close off the points of water entry at the first course of masonry above the finished ground level, as well as at other points of support such as at shelf angles and lintels. As always, flashing must be of an approved corrosion-resistant material. From the Commentary to the IRC.

R703.7.6 Weepholes.

Weepholes shall be provided in the outside Wythe of masonry walls at a maximum spacing of 33 inches (838 mm) on center. Weepholes shall not be less than 3/16 inch (5 mm) in diameter. Weepholes shall be located immediately above the flashing.

At a point directly above the flashing mandated by Section R703.7.5, weepholes must be provided to allow for the escape of any moisture that may have penetrated the masonry veneer. Because moisture will adversely affect the integrity of the wall if not removed from the wall assembly, weepholes must be installed within the maximum spacing specified in this section. The minimum diameter of the weepholes is also regulated. From the Commentary to the IRC.

R703.8 Flashing.

Approved corrosion-resistant flashing shall be applied shingle-fashion in such a manner to prevent entry of water into the wall cavity or penetration of water to the building structural framing components. The flashing shall extend to the surface of the exterior wall finish. Approved corrosion-resistant flashings shall be installed at all of the following locations:

1. Exterior window and door openings. Flashing at exterior window and door openings shall extend to the surface of the exterior wall finish or to the water-resistive barrier for subsequent drainage.
2. At the intersection of chimneys or other masonry construction with frame or stucco walls, with projecting lips on both sides under stucco copings.
3. Under and at the ends of masonry, wood or metal copings and sills.
4. Continuously above all projecting wood trim.
5. Where exterior porches, decks or stairs attach to a wall or floor assembly of wood-frame construction.
6. At wall and roof intersections.
7. At built-in gutters.

The code requires that all points subject to the entry of moisture be appropriately flashed. Roof and wall intersections and parapets create significant challenges, as do exterior wall openings exposed to the weather. Where wind-driven rain is expected, the concerns are even greater. Although the code identifies a number of

I=Inspected

NI=Not Inspected

NP=Not Present

D= Deficiency

I	NI	NP	D
---	----	----	---

locations where flashing is specifically required, the entire exterior envelope must be weather-tight to protect the interior from weather. Therefore, any location on the exterior envelope that provides a route for the admission of water or moisture into the building must be properly protected. Commentary Figure R703.8 illustrates examples of flashing. From the Commentary to the IRC.

HOSE BIBS

Hose bibs are a source of water which increases the likelihood of moisture related problems. The goal is to keep the water outside of the building and the best way to do this is keep the water off the walls. A good preventative measure is to extend the hose bib further from the wall. A downward slope on the water pipe as it leaves the building will also encourage any slow leaks to fall away from the home.

Large piping over 1 1/2" diameter is required to have blocking and flashing at the penetration. A block of HardieTrim® 5/4, 4/4 boards should be installed around the point of penetration. To install a block around an existing pipe, it may be necessary to cut the block into two pieces. In this case, weather-cut the trim to fit it into place. Install flashing over the top of the trim block.

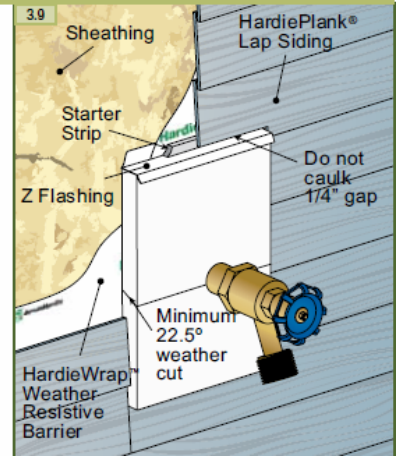

LIGHTS AND ELECTRICAL OUTLETS

Lights and Electrical boxes should have the same flashing and blocking as other large penetrations such as vents. Many lights utilize square electrical boxes. Blocking a square object should still incorporate the best practices of an angled weather cut.

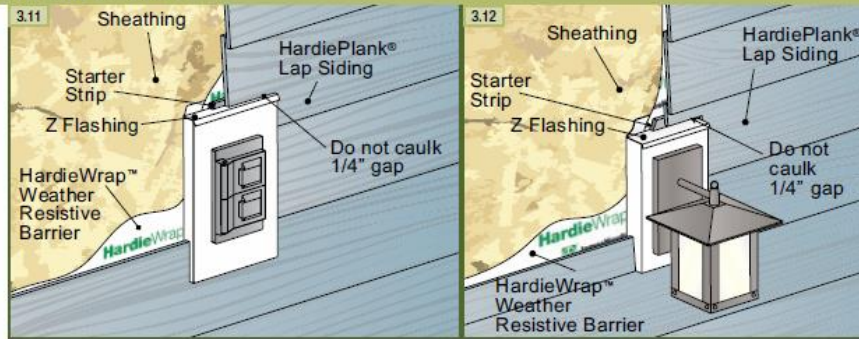

I=Inspected

NI=Not Inspected

NP=Not Present

D= Deficiency

I	NI	NP	D
---	----	----	---

PENETRATIONS

For penetrations in the building envelope such as hose bibs and holes 1 1/2" diameter or larger, such as dryer vents, a block of HardieTrim® 5/4, 4/4 boards should be installed around the point of penetration. To install a block around an existing vent pipe, it may be necessary to cut the block into two pieces. In this case, weather-cut the trim to fit into place. Install flashing over the top of the trim block.

Penetrations through a building envelope are made to accommodate needs such as hose bibs, dryer and furnace vents, electrical conduit, etc. It is important to restore the weather-resistant barrier of the home after cutting a hole for the penetration.

There are several pre-made blocking and flashing products available that can simplify the installation of a penetration. One such example is Sturdimount®. Be sure to follow all manufactures installation instructions.

Courtesy of James Hardie Products, Inc.

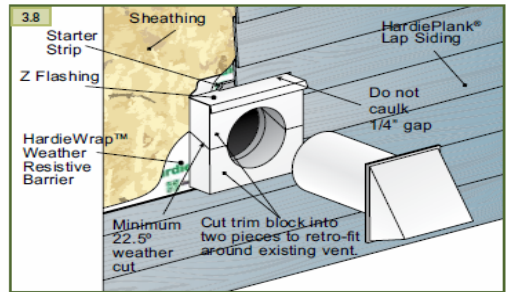

PENETRATIONS

For penetrations in the building envelope such as hose bibs and holes 1 1/2" diameter or larger, such as dryer vents, a block of HardieTrim® 5/4, 4/4 boards should be installed around the point of penetration. To install a block around an existing vent pipe, it may be necessary to cut the block into two pieces. In this case, weather-cut the trim to fit into place. Install flashing over the top of the trim block.

Penetrations through a building envelope are made to accommodate needs such as hose bibs, dryer and furnace vents, electrical conduit, etc. It is important to restore the weather-resistant barrier of the home after cutting a hole for the penetration.

There are several pre-made blocking and flashing products available that can simplify the installation of a penetration. One such example is Sturdimount®. Be sure to follow all manufactures installation instructions.

Courtesy of James Hardie Products, Inc.

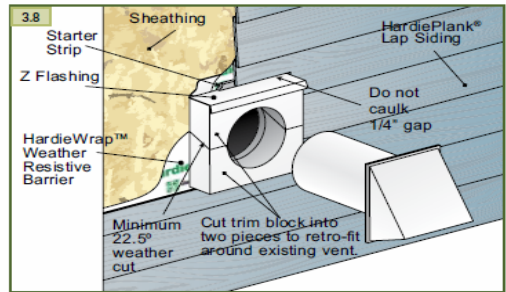

Deficiency: Portions of the cladding system were stucco veneer. Proper flashing and drain plane terminations were not visible in all required areas such as wall penetrations and wall terminations. While metal flashing was installed, for example, above the windows there were no drain planes installed at the flashing. Wall termination drains were installed in some areas, but were blocked and did not appear to be effective. Flashing is intended to prevent water infiltrating the wall system and to allow water created from condensation in the wall to escape the wall system. Water held in the wall sheathing and/or framing can and may cause deterioration of the wooden members of the house and the growth of harmful microbial organisms and these organisms can affect the indoor air quality of the house.

I=Inspected

NI=Not Inspected

NP=Not Present

D= Deficiency

I	NI	NP	D
---	----	----	---



Information: Historically, few stucco clad homes were ever constructed in the Greater Houston area. When houses did not have central air conditioning there was no means for nature to produce condensation in the wall system. When homes were equipped with central air and heat, the walls were not insulated to the degree that the house was sealed or substantially sealed. When air and water are easily exchanged from the outside atmosphere even if water condensed in the wall cavity there was little chance of the house being labeled a “sick building” as mold spores were also readily exchanged with the outdoor atmosphere. In recent years, stucco has become a popular cladding material in the Greater Houston area. Unfortunately, the only stucco masons available to us came from the desert climates. If there is less than 10 inches of rain per year and when the indoor air has a higher water content (higher humidity) than the outside air, water flows from the interior, wetter living space to the outside (drier) atmosphere. Again, there is little danger of water being trapped in the wall system or of molds developing.

In the Greater Houston area, for the vast majority of each year, it is hotter and wetter outside of the house. In this area, both heat and water are trying to get through the wall system and into the house. As such, condensation forms in the wall cavities.

If we only needed to be concerned with rain water entering the wall system, the way Z flashings and other wall flashing materials, along with properly installed elastomeric paint, might be sufficient to keep most of the water out of the wall cavity. However, our problems with stucco are from water being held in the wall cavity by nonexistent or obstructed drainways.

Examples of some of the details of proper through wall drains are shown below for clarity only.

I=Inspected

NI=Not Inspected

NP=Not Present

D= Deficiency

I	NI	NP	D
---	----	----	---

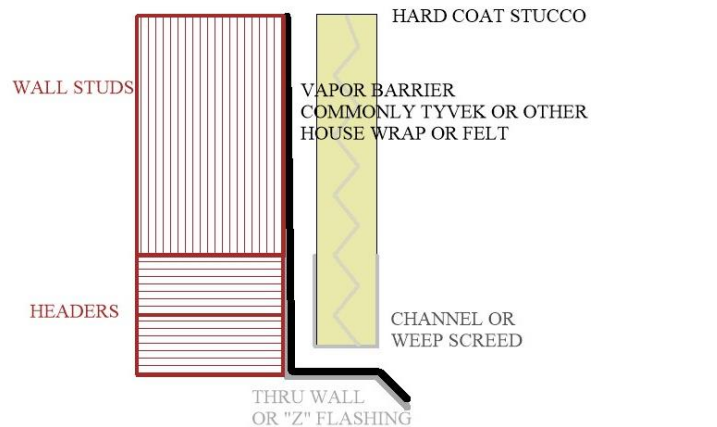

WINDOW OR DOOR
PENETRATION

DETAIL DESCRIPTION IS FOR
EXPLANATION PURPOSES ONLY.
THE DETAIL IS NOT A DESIGN FOR
WALL DRAINAGE.

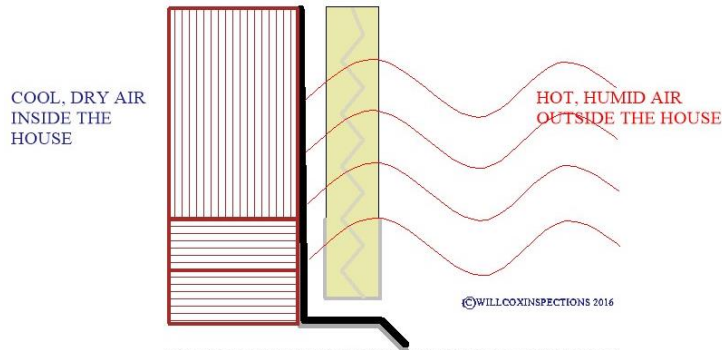

WATER MOVES FROM WET TO DRY, OR FROM HIGH
HUMIDITY TO LOWER HUMIDITY

HEAT MOVES FROM HOT TO COLD

IN OUR AREA THE OUTSIDE ATMOSPHERE CRASHES INTO
OUR HOUSES TRYING TO GET INSIDE THE HOUSE

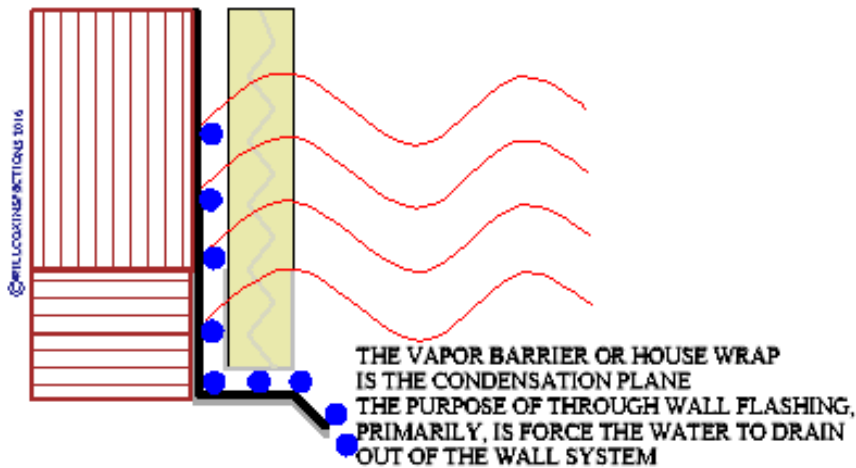

The following drawings show how stucco is commonly installed in the Greater Houston area.

I=Inspected

NI=Not Inspected

NP=Not Present

D= Deficiency

I	NI	NP	D
---	----	----	---

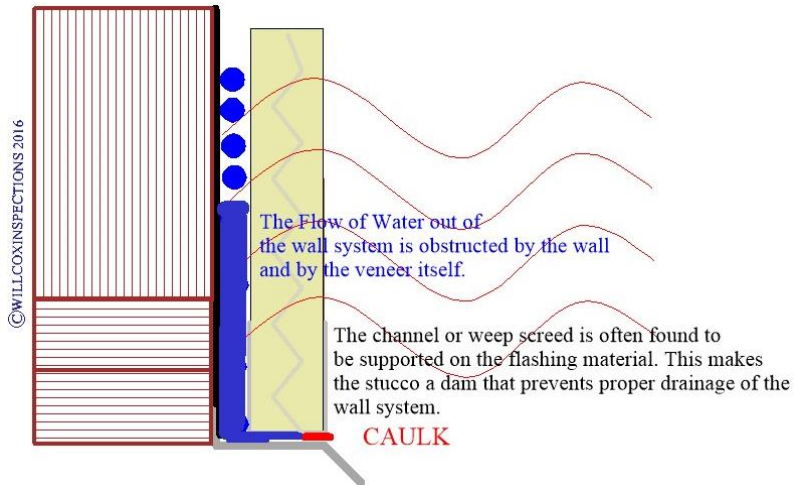
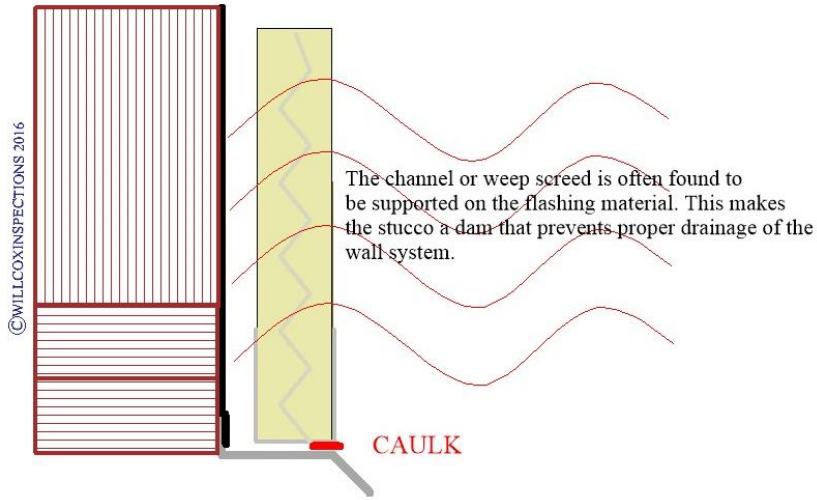

An example of proper cantilevered wall termination and samples of wall drain products are shown below.

I=Inspected

NI=Not Inspected

NP=Not Present

D= Deficiency

I	NI	NP	D
---	----	----	---

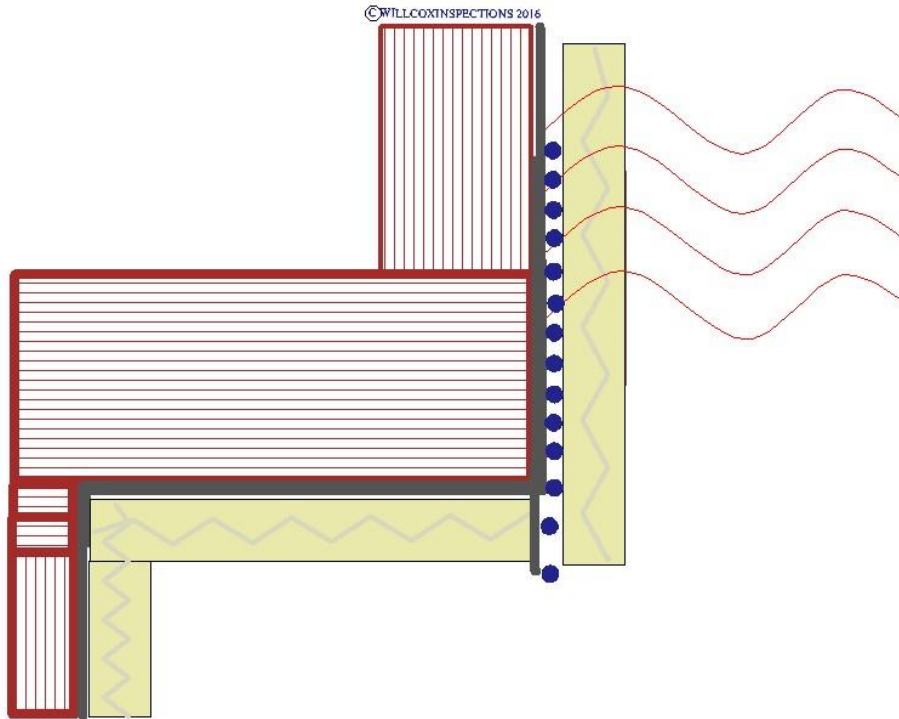

Stucco and Plaster

Drip Screed

Product #	Ground Dimensions	Descriptions	Pieces/Box
540-38	3/8"	Soffit drip screed with 2" x 2" perforated flange.	15
540-50	1/2"		15
540-58	5/8"		15
540-75	3/4"		15
540-78	7/8"		15
10' Lengths			

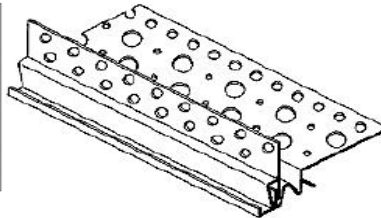

Application:

Prevents water from turning under and back into the soffit. Also serves as an expansion joint.

Specification:

DripScreed shall be Plastic Components, Inc. # _____. All exterior accessories shall be of PVC material conforming to ASTM standards D1784-92 and C1063-94. They shall be used where specified by the architect and installed per industry standards and manufacturer's instructions.

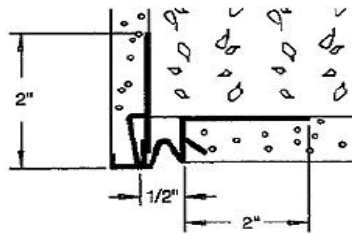

Caulk all butt joints, intersections and ends.
It is recommended that PVC products be used for all exterior exposures.

Wall termination drain detail courtesy of Plastic Components, Inc.

The drawing below shows the common installation of stucco at cantilevered wall terminations in the Greater Houston area.

I=Inspected

NI=Not Inspected

NP=Not Present

D= Deficiency

I	NI	NP	D
---	----	----	---

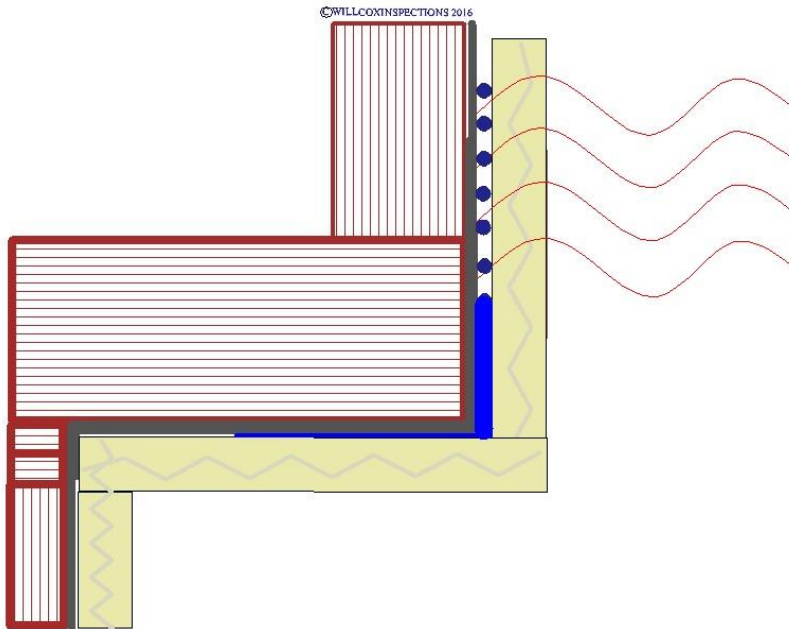

The lack of a drain allows water to collect in the wall system.

The only way to prevent this occurrence is to prevent as much water as possible from entering the wall cavities and to provide wall cavity drains at bottoms of all wall terminations. To reduce, as much as possible, water penetration into the wall cavities, all wall penetrations including window frames, door frames, vent penetrations, pipe entrances, electrical disconnects, and conduits, etc. must be flashed, sealed and provided with drain openings. Proper flashings and seals terminated on the exterior of the veneer as required by building codes and by lathing and plastering association rules of proper installation procedures can be easily seen. Drain planes must be installed at the bottom of all wall terminations whether ground or cantilevered wall terminations. Through wall flashing materials can be easily installed once the veneer is constructed. Through wall flashings were found at the tops of most of the window and door penetrations however, the drain ways for the flashing materials were obstructed rendering the drain useless. No through wall flashing materials were found under the window sills or at other wall penetrations. There were no drain openings observed at the cantilevered wall terminations. This inspection DOES NOT include an indoor air quality test. This inspection DOES NOT AND CANNOT test for future events which include the growth of microbial organic organisms in the wall cavities, structural framing and/or on the interior surfaces of the house. Liability for present and future microbial organic organisms and the results of their presence is specifically excluded from the inspection and from this report. It should not be assumed that only areas with visible evidence of water penetration as described in this report were the only areas of concern. Once water intrusion occurs, moisture may be trapped in the wall system, which may result in damaged materials and the subsequent decay of structural members. The extent of damage cannot be positively determined as set forth by the scope of this visual inspection.

It should be noted that proper (industry accepted) repairs include correction of the sources of water penetration and the installation of drains. In addition it is necessary that all moisture / water affected materials be addressed. Guide lines on how each type of material should be addressed should be taken from sources who provide "industry standards" such as those as written and published by The Association of Specialists in Cleaning and Restoration (ASCR) at 800-272-7012 or via their web site at: <http://www.ascr.org/> or by The Institute of Inspection, Cleaning and Restoration Certification (IIRCRC) at (360) 693-5675 or via their web site at: <http://www.iircrc.org/>. Another good source where information may be obtained is the U.S. Environmental Protection Agency at: (202) 343-9370 or via their web site at: <http://www.epa.gov/mold/>.

I=Inspected

NI=Not Inspected

NP=Not Present

D= Deficiency

I	NI	NP	D
---	----	----	---

References: 703.7.5 Flashing of the IRC and Multiple other sources.

703.7.5 Flashing.

Flashing shall be located beneath the first course of masonry above finished ground level above the foundation wall or slab and at other points of support, including structural floors, shelf angles and lintels when masonry veneers are designed in accordance with Section R703.7. See Section R703.8 for additional requirements.

R703.7.6 Weepholes.

Weepholes shall be provided in the outside Wythe of masonry walls at a maximum spacing of 33 inches (838 mm) on center. Weepholes shall not be less than 3/16 inch (5 mm) in diameter. **Weepholes shall be located immediately above the flashing.**

Weepholes must be provided directly above the flashing mandated by Section R703.7.5 to allow for the escape of any moisture that may have penetrated the masonry veneer. Because moisture will adversely affect the integrity of the wall if not removed from the wall assembly, weep holes must be installed within the maximum spacing specified in this section. The minimum diameter of the weep holes is also stipulated. From the Commentary to the IRC.

R703.8 Flashing.

Approved corrosion-resistant flashing shall be applied shingle-fashion in a manner to prevent entry of water into the wall cavity or penetration of water to the building structural framing components. Self-adhered membranes used as flashing shall comply with AAMA 711. The flashing shall extend to the surface of the exterior wall finish. Approved corrosion-resistant flashings shall be installed at all of the following locations:

1. Exterior window and door openings. Flashing at exterior window and door openings shall extend to the surface of the exterior wall finish or to the water-resistive barrier for subsequent drainage.
2. At the intersection of chimneys or other masonry construction with frame or stucco walls, with projecting lips on both sides under stucco copings.
3. Under and at the ends of masonry, wood or metal copings and sills.
4. Continuously above all projecting wood trim.
5. Where exterior porches, decks or stairs attach to a wall or floor assembly of wood-frame construction.
6. At wall and roof intersections.
7. At built-in gutters.

SECTION III

CEMENT PLASTER/STUCCO

TEXAS LATHING AND PLASTERING CONTRACTORS ASSOCIATION

& THE TEXAS BUREAU FOR LATHING AND PLASTERING Systems Manual

Issue – 01/12/02 **Copyright 2001, TLPCA/TBLP Page 77**

Termination of Stucco at Foundation

Facts You Should Know

At the foundation plate line, and/or where the bottom of the stucco wall terminates, a continuous trim accessory consisting of a foundation weep screed, casing bead or a special trim design is required. The function of the termination trim accessory is to provide a cement plaster stop a straight and level finish edge for the stucco system and to establish a uniform thickness grounds for the cement plaster. The foundation trim accessory is to be installed just below the floor line wherever a floor or foundation supports the wall. The water-resistant barrier (paper) is to extend

I=Inspected

NI=Not Inspected

NP=Not Present

D= Deficiency

I	NI	NP	D
---	----	----	---

past the floor line, overlapping the foundation screed flange. The lath is to be installed over the trim accessory flanges.

The continuous termination trim accessories are to be attached 12 inches (300 mm) o/c. to the framing system, not to the foundation. Manufactured trim accessories shall be fabricated from zinc, galvanized steel, rigid PVC (plastic) or anodized aluminum.

Place the bottom edge of the termination trim not less than 1 inch (25 mm) below the joint formed by the foundation and the framing. The finished edge of the stucco wall should be located not less than 4 inches (102 mm) above raw earth or 2 inches (51 mm) above paved surfaces.

CROSS SECTION OF WINDOW SHOWING INTEGRATION OF STRUCTURE'S WEATHER-RESISTIVE SYSTEM IN A WALL WITH PORTLAND CEMENT STUCCO EXTERIOR WALL COVERING

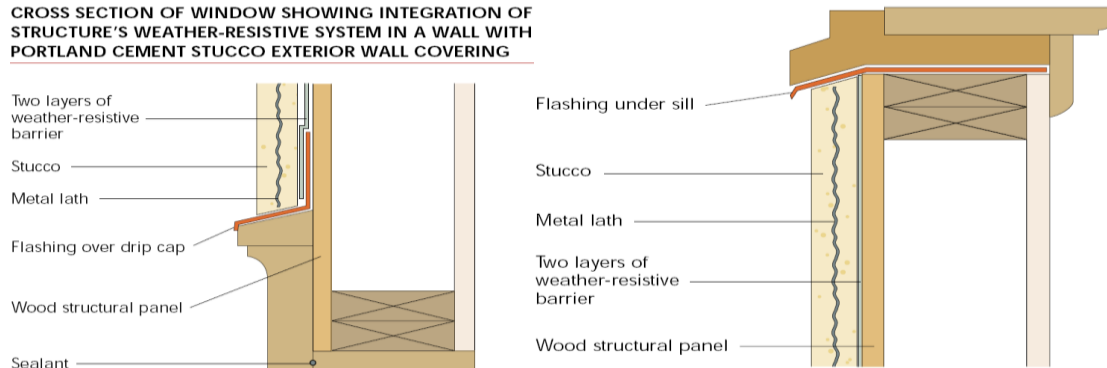

FLASHING INSTALLATION AT TERMINATION OF PORTLAND CEMENT STUCCO EXTERIOR WALL COVERING

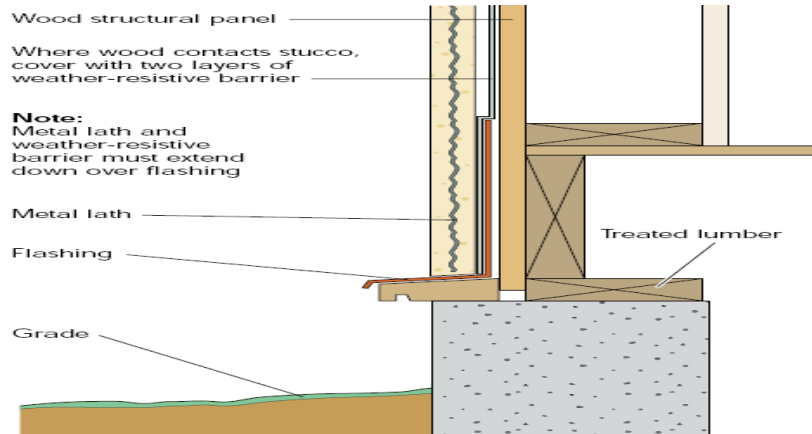

COURTESY APAWOOD.ORG

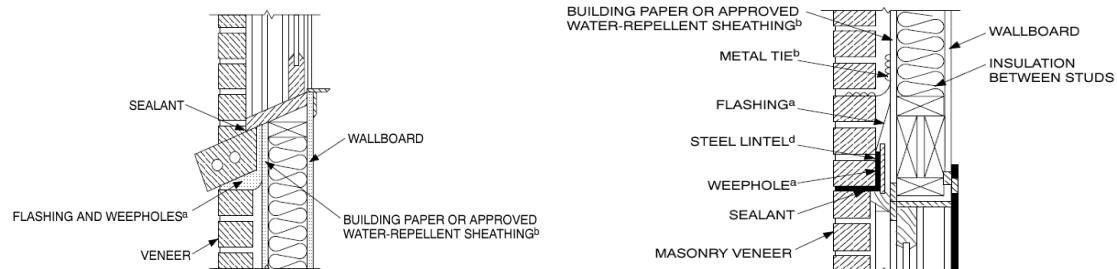

Courtesy of ICC, Inc.

I=Inspected

NI=Not Inspected

NP=Not Present

D= Deficiency

I	NI	NP	D
---	----	----	---

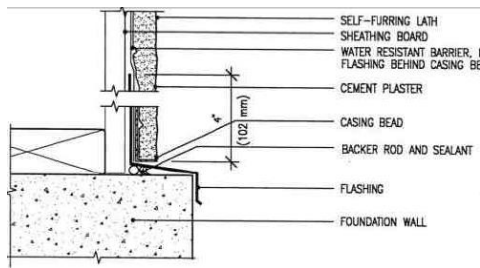

T1 - Casing Bead at Concrete Foundation

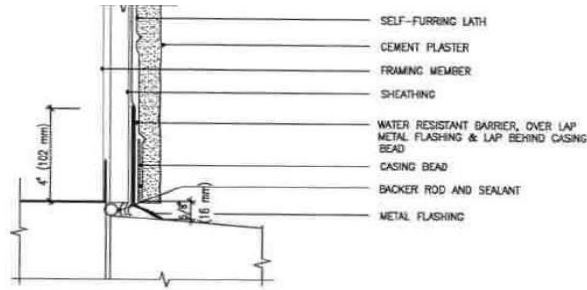

T4 - Termination at Slab/Sidewalk

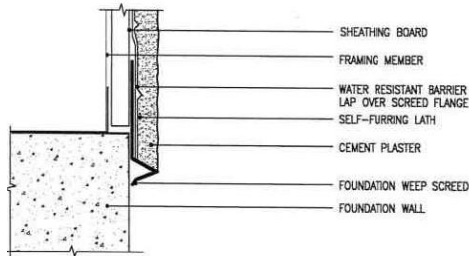

T2 - Weep Screenshot at Concrete Foundation

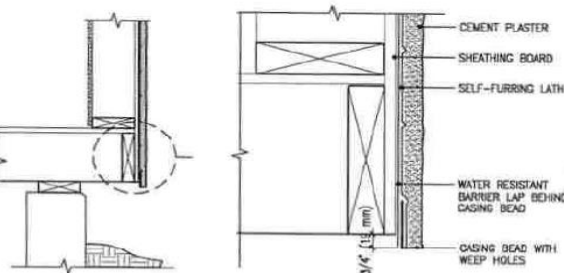

T5 - Termination at Cantilevered Wall

Courtesy of the TEXAS LATHING AND PLASTERING CONTRACTORS ASSOCIATION

Deficiency: The control joints in the stucco veneer were improperly constructed.

Information: For control joints to relieve the stress associated with thermal and water expansion and contraction of the stucco wall the control joint must create a complete separation. The weep screed or channel supporting the stucco was continuous. Proper control joints should be created.

Reference: *Courtesy of the TEXAS LATHING AND PLASTERING CONTRACTORS ASSOCIATION, Inc.*

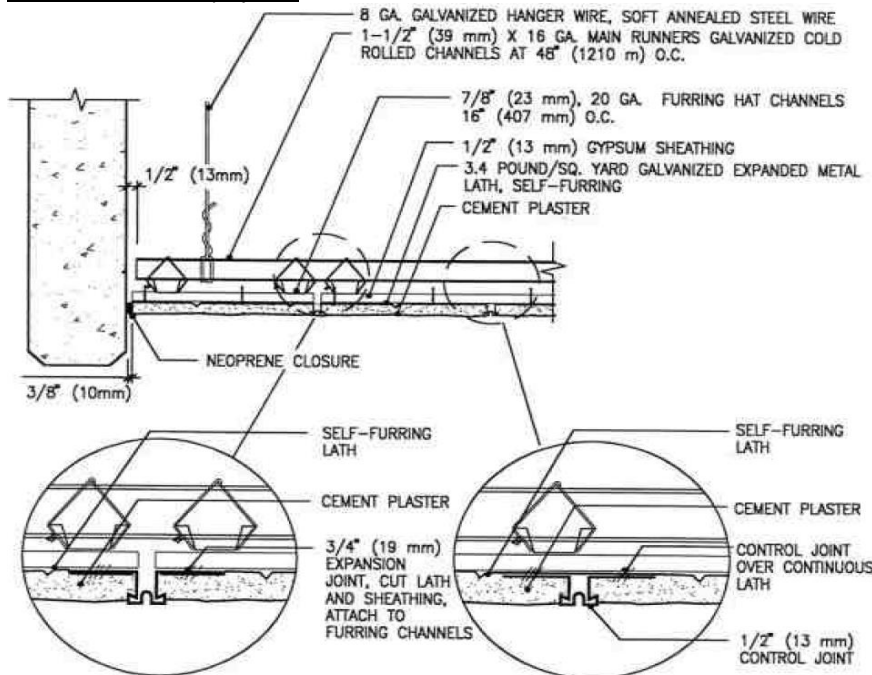

I=Inspected

NI=Not Inspected

NP=Not Present

D= Deficiency

I	NI	NP	D
---	----	----	---

Deficiency: There were cracks in the stucco veneer.

Information: The cause(s) of the cracks should be determined and corrected. The cracked panels should be replaced with new panels finished to match the existing structure.

NOTICE: Sections of stucco veneer appeared to have been patched or replaced.

Information: Information on the reasons for the patch should be obtained from the current owner. Information on how the patch was installed should also be obtained. Wet cement does not bond well to dry cement. Patches in stucco veneer are difficult to make so that the new cement adheres to the older cement and so that the joint is as water tight as any other section of the wall.

■ □ □ ■ **F. Ceilings & Floors**

Comments:

Items noted during the visual inspection that were deemed deficient, are in need of repair, adjustment, restoration, that require comment, continuation of the due diligence process and/or servicing or items noted for information include but are not limited to:

Deficiency: Portions of the floor covering materials were not properly secured as observed throughout the home. Installation was incomplete in some areas such as the Kitchen at the dishwasher.

Information: Floor covering materials should be installed in accordance with manufacturer installation instructions.

■ □ □ ■ **G. Doors (Interior & Exterior)**

Comments:

Items noted during the visual inspection that were deemed deficient, are in need of repair, adjustment, restoration, that require comment, continuation of the due diligence process and/or servicing or items noted for information include but are not limited to:

Deficiency: Water damage was noted at portions of the exterior doors and related components (including interior) at the balcony.



I=Inspected

NI=Not Inspected

NP=Not Present

D= Deficiency

I	NI	NP	D
---	----	----	---

Information: The sources of the water penetration should be determined and repaired. The presence of water penetration may indicate the growth of microbial organic organisms that may be toxic. Indoor air quality tests are not a part of this inspection. Should you desire an indoor air quality test, the test should be arranged prior to closing. Once the sources of the water penetration have been determined and repaired, all decayed, deteriorated or damaged materials, including walls covering materials, trim, moldings, insulating materials and framing members should be removed and replaced and finished to match the existing structure.

Deficiency: The weather stripping on the exterior door frames was damaged and/or inadequate.

Information: Daylight could be seen between the doors and the door frames. The weather stripping reduces the exchange of air between the exterior and the interior of the house. The weather stripping should be replaced.

Deficiency: Some of the interior doors were damaged.



Information: Repair or replacement of the doors is recommended.

Deficiency: Some of the doors did not latch in the closed position.

Information: The doors or the striker plates should be adjusted so that the doors latch properly.

Deficiency: Hardware and doorstops were missing from (exterior and interior) doors throughout the house. Damaged doorstops were observed.

Information: All hardware and door stops should be installed and should be operating properly prior to the termination of any due diligence investigation period.

Deficiency: Some of the doors swing shut.

Information: The friction on the hinges should be increased so that the doors will remain open.

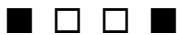

H. Windows

Comments:

Items noted during the visual inspection that were deemed deficient, are in need of repair, adjustment, restoration, that require comment, continuation of the due diligence process and/or servicing or items noted for information include but are not limited to:

I=Inspected

NI=Not Inspected

NP=Not Present

D= Deficiency

I	NI	NP	D
---	----	----	---

Deficiency: There were no emergency escape and rescue openings in the downstairs bedroom of the structure.

References: Sections R310.1 through R310.1.3

R310.1 Emergency escape and rescue required. Basements with habitable space and every sleeping room shall have at least one openable emergency escape and rescue opening. Where basements contain one or more sleeping rooms, emergency egress and rescue openings shall be required in each sleeping room, but shall not be required in adjoining areas of the basement. Where emergency escape and rescue openings are provided they shall have a sill height of not more than 44 inches (1118 mm) above the floor. Where a door opening having a threshold below the adjacent ground elevation serves as an emergency escape and rescue opening and is provided with a bulkhead enclosure, the bulkhead enclosure shall comply with Section 310.3. The net clear opening dimensions required by this section shall be obtained by the normal operation of the emergency escape and rescue opening from the inside. Emergency escape and rescue openings with a finished sill height below the adjacent ground elevation shall be provided with a window well in accordance with Section R310.2.

R310.1.1 Minimum opening area. All emergency escape and rescue openings shall have a minimum net clear opening of 5.7 square feet (0.530 m²).

R310.1.2 Minimum opening height. The minimum net clear opening height shall be 24 inches (610 mm).

R310.1.3 Minimum opening width. The minimum net clear opening width shall be 20 inches (508 mm).

Deficiency: In my opinion, some of the windows were difficult to open, close and/or latch.

Information: The windows should be adjusted to open, close and latch properly. The bedroom windows are considered emergency escapes. If the windows are difficult to operate, the occupant of the room may not be able to escape during a fire or other emergency.

Deficiency: The window frames had been drilled to allow passage of the conductors for the alarm sensors.



Information: Many window manufacturers do not allow the frames of their windows to be damaged or altered in any way. Holes drilled through the window frames may have voided the window manufacturer's warranty. You should determine if the warranty on these windows is still valid.

I=Inspected

NI=Not Inspected

NP=Not Present

D= Deficiency

I	NI	NP	D
---	----	----	---

Deficiency: The windows did not have screens.

Information: Screens should be installed on all openable windows. Screens are required to reduce diseases from insects.

■ □ □ ■

I. Stairways (Interior & Exterior)

Comments:

Items noted during the visual inspection that were deemed deficient, are in need of repair, adjustment, restoration, that require comment, continuation of the due diligence process and/or servicing or items noted for information include but are not limited to:

Deficiency: The exterior and interior guardrails may create a ladder effect.

Information: The IRC prohibits the use of guardrails on porches or staircases that create a ladder effect. The guardrails appeared to create such an effect. You are advised that this type of guardrail creates a hazard, particularly to small children who may climb the railing.

Deficiency: A guardrail was not observed on a portion of the 3rd floor.



312.1 Guards required.

Porches, balconies or raised floor surfaces located more than 30 inches (762 mm) above the floor or grade below shall have guards not less than 36 inches (914 mm) in height. Open sides of stairs with a total rise of more than 30 inches (762 mm) above the floor or grade below shall have guards not less than 34 inches (864 mm) in height measured vertically from the nosing of the treads.

□ □ ■ □

J. Fireplaces and Chimneys

Comments:

■ □ □ ■

K. Porches, Balconies, Decks, and Carports

Comments:

Items noted during the visual inspection that were deemed deficient, are in need of repair, adjustment, restoration, that require comment, continuation of the due diligence process and/or servicing or items noted for information include but are not limited to:

I=Inspected

NI=Not Inspected

NP=Not Present

D= Deficiency

I	NI	NP	D
---	----	----	---

Deficiency: The exterior guardrails may create a ladder effect.



Information: The IRC prohibits the use of guardrails on porches or staircases that create a ladder effect. The guardrails appeared to create such an effect. You are advised that this type of guardrail creates a hazard, particularly to small children who may climb the railing.

Deficiency: The bolts securing the guard railings to the balcony may have penetrated the water proofing system.

Information: If the bolts penetrated the water proofing system the water proofing system will ultimately leak. The method of attachment of the bolts should be determined. If the water proofing system has been compromised the water proofing system should be replaced.



Deficiency: Ponding water and deflections were observed in portions of the upper balcony wood deck materials.

I=Inspected

NI=Not Inspected

NP=Not Present

D= Deficiency

I	NI	NP	D
---	----	----	---



Deficiencies: Water damaged and/or wet (to the touch) materials were observed on the attic interior common wall for the HVAC equipment room / attic. The wet materials were not limited to the area near the exterior door. A properly sloped pan and water-proof methods used beneath the deck could not be observed at the time of the inspection.



I=Inspected

NI=Not Inspected

NP=Not Present

D= Deficiency

I	NI	NP	D
---	----	----	---



Information: Pans beneath decked areas should be adequately sloped to allow for swift water removal toward scuppers. A scupper is an opening in a wall that allows water to drain from the pan beyond the surface of the exterior wall finish to prevent interior water penetration. Scuppers should be properly sized and installed to minimize the risk of interior water penetration.

Information: The sources of the water penetration should be determined and repaired. The presence of water penetration may indicate the growth of microbial organic organisms that may be toxic. Indoor air quality tests are not a part of this inspection. Should you desire an indoor air quality test, the test should be arranged prior to closing. Once the sources of the water penetration have been determined and repaired, all decayed, deteriorated or damaged materials, including walls covering materials, trim, moldings, insulating materials and framing members should be removed and replaced and finished to match the existing structure.

Deficiency: In my opinion, the surface of the front balcony was inadequately sloped to drain water off the deck. Gaps were observed in portions of the flashing.

I=Inspected

NI=Not Inspected

NP=Not Present

D= Deficiency

I	NI	NP	D
---	----	----	---



Information: The balcony surface must be sloped to drain water completely off the balcony and over the edge of the balcony for drainage. Water standing on the surface of the balcony will ultimately cause the balcony to leak.

Deficiency: The water proofing system for the balconies were not visible.

Information: The type of water proofing system and its proper operation should be determined prior to the closing on the house. Balconies over interior wall spaces and living spaces tend to cause problems in areas of high rain fall. You should make every effort to determine that the water proofing system will be effective for a prolonged period of time. As the water proofing system was not visible, the water proofing system of the balcony is specifically excluded from the inspection and from this report.

I=Inspected

NI=Not Inspected

NP=Not Present

D= Deficiency

I	NI	NP	D
---	----	----	---

Deficiency: The surfaces of the balconies were in contact with or were too close to the stucco and wood fiber product systems. The drainage of the wall cavity was partially or completely obstructed.

Information: Current building codes provide that the elevation of ground surfaces, sidewalks, porches, patios or driveways, etc. cannot be closer than four inches to the elevation of the surface of the foundation or the bottom of the masonry claddings of a house. Having the elevation of the balcony raised so that the balcony is close to the elevation of the interior floor can allow water to enter the structure. The elevation of the balcony should be lowered to provide adequate spacing to the stucco veneer and to reduce the chances of water or splash from entering the house.

Reference: *R404.1.6 Height above finished grade. Concrete and masonry foundation walls shall extend above the finished grade adjacent to the foundation at all points a minimum of 4 inches (102 mm) where masonry veneer is used and a minimum of 6 inches (152 mm) elsewhere.*

Deficiency: There were no parapet caps on top of the wood fiber products balcony guard rail walls.



Information: All masonry materials absorb water. The tops of all masonry walls that are exposed to the elements are required to be covered with a water proof material. Parapet caps should be installed to prevent water penetration. Wood fiber products materials are not manufactured for use horizontally. The wood fiber products material should be replaced with materials approved for horizontal installation. Proper parapet caps should be installed to reduce the chances of water penetration.

Reference: *Courtesy of James Hardie, Inc.*

I=Inspected NI=Not Inspected NP=Not Present D= Deficiency

I	NI	NP	D
---	----	----	---

IMPORTANT: FAILURE TO INSTALL AND FINISH THIS PRODUCT IN ACCORDANCE WITH APPLICABLE BUILDING CODES AND JAMES HARDIE WRITTEN APPLICATION INSTRUCTIONS MAY LEAD TO PERSONAL INJURY, AFFECT SYSTEM PERFORMANCE, VIOLATE LOCAL BUILDING CODES, AND VOID THE PRODUCT ONLY WARRANTY. BEFORE INSTALLATION, CONFIRM THAT YOU ARE USING THE CORRECT HARDIEZONE™ PRODUCT INSTRUCTIONS. INSTALLATION OF HZ10® PRODUCTS OUTSIDE AN HZ10® LOCATION WILL VOID YOUR WARRANTY. TO DETERMINE WHICH HARDIEZONE™ APPLIES TO YOUR LOCATION, VISIT WWW.HARDIEZONE.COM OR CALL 1-866-942-7343 (866 9HARDIE)

<p>STORAGE & HANDLING:</p> <p>Store flat and keep dry and covered prior to installation. Installing siding wet or saturated may result in shrinkage at butt joints. Carry planks on edge. Protect edges and corners from breakage. James Hardie is not responsible for damage caused by improper storage and handling of the product.</p> 	<p style="text-align: center;">CUTTING INSTRUCTIONS</p> <p style="text-align: center;">▲</p> <table border="1"> <tr> <td style="width: 50%; vertical-align: top;"> <p>OUTDOORS</p> <ol style="list-style-type: none"> Position cutting station so that wind will blow dust away from user and others in working area. Use one of the following methods: <ol style="list-style-type: none"> Best: <ol style="list-style-type: none"> Score and snap Shears (manual, electric or pneumatic) Better: <ol style="list-style-type: none"> Dust reducing circular saw equipped with a HardieBlade® saw blade and HEPA vacuum extraction Good: <ol style="list-style-type: none"> Dust reducing circular saw with a HardieBlade saw blade (only use for low to moderate cutting) </td> <td style="width: 50%; vertical-align: top;"> <p>INDOORS</p> <ol style="list-style-type: none"> Cut only using score and snap, or shears (manual, electric or pneumatic). Position cutting station in well-ventilated area <p>- NEVER use a power saw indoors - NEVER use a circular saw blade that does not carry the HardieBlade saw blade trademark - NEVER dry sweep – Use wet suppression or HEPA Vacuum</p> </td> </tr> </table> <p><small>Important Note: For maximum protection (lowest respirable dust production), James Hardie recommends always using "Best"-level cutting methods where feasible.</small></p> <p><small>NIOSH-approved respirators can be used in conjunction with above cutting practices to further reduce dust exposures. Additional exposure information is available at www.jameshardie.com to help you determine the most appropriate cutting method for your job requirements. If concern still exists about exposure levels or you do not comply with the above practices, you should always consult a qualified industrial hygienist or contact James Hardie for further information.</small></p> <p style="text-align: right;"><small>SC083105</small></p>	<p>OUTDOORS</p> <ol style="list-style-type: none"> Position cutting station so that wind will blow dust away from user and others in working area. Use one of the following methods: <ol style="list-style-type: none"> Best: <ol style="list-style-type: none"> Score and snap Shears (manual, electric or pneumatic) Better: <ol style="list-style-type: none"> Dust reducing circular saw equipped with a HardieBlade® saw blade and HEPA vacuum extraction Good: <ol style="list-style-type: none"> Dust reducing circular saw with a HardieBlade saw blade (only use for low to moderate cutting) 	<p>INDOORS</p> <ol style="list-style-type: none"> Cut only using score and snap, or shears (manual, electric or pneumatic). Position cutting station in well-ventilated area <p>- NEVER use a power saw indoors - NEVER use a circular saw blade that does not carry the HardieBlade saw blade trademark - NEVER dry sweep – Use wet suppression or HEPA Vacuum</p>
<p>OUTDOORS</p> <ol style="list-style-type: none"> Position cutting station so that wind will blow dust away from user and others in working area. Use one of the following methods: <ol style="list-style-type: none"> Best: <ol style="list-style-type: none"> Score and snap Shears (manual, electric or pneumatic) Better: <ol style="list-style-type: none"> Dust reducing circular saw equipped with a HardieBlade® saw blade and HEPA vacuum extraction Good: <ol style="list-style-type: none"> Dust reducing circular saw with a HardieBlade saw blade (only use for low to moderate cutting) 	<p>INDOORS</p> <ol style="list-style-type: none"> Cut only using score and snap, or shears (manual, electric or pneumatic). Position cutting station in well-ventilated area <p>- NEVER use a power saw indoors - NEVER use a circular saw blade that does not carry the HardieBlade saw blade trademark - NEVER dry sweep – Use wet suppression or HEPA Vacuum</p>		

GENERAL REQUIREMENTS:

- HardiePlank® lap siding can be installed over braced wood or steel studs spaced a maximum of 24" o.c. or directly to minimum 7/16" thick OSB sheathing. See general fastening requirements. Irregularities in framing and sheathing can mirror through the finished application.
- Information on installing James Hardie products over foam can be located in **JH Tech Bulletin 19** at www.jamehardie.com
- A water-resistive barrier is required in accordance with local building code requirements. The water-resistive barrier must be appropriately installed with penetration and junction flashing in accordance with local building code requirements. James Hardie will assume no responsibility for water infiltration. James Hardie does manufacture HardieWrap® Weather Barrier, a non-woven non-perforated housewrap¹, which complies with building code requirements.
- When installing James Hardie products all clearance details in figs. 3-14 must be followed.
- Adjacent finished grade must slope away from the building in accordance with local building codes - typically a minimum of 6" in the first 10'.
- Do not use HardiePlank lap siding in fascia or trim applications.
- Do not install James Hardie products, such that they may remain in contact with standing water.



Deficiency: The surfaces of the porches were in contact with or were too close to the exterior cladding systems. The drainage of the wall cavity was partially or completely obstructed.

Information: Current and past building codes provide that the elevation of ground surfaces, sidewalks, porches, patios, decks or driveways, etc. cannot be closer than four inches to the elevation of the surface of the foundation or the bottom of the claddings of a house if the cladding system is masonry and six inches if the cladding system is other than masonry. Having the elevation of the ground surfaces raised so that the ground surfaces are in contact with the veneer can allow water to be trapped in or against the veneer. The elevations of the ground surfaces should be lowered, and the yards should be sloped to drain water away from the structure, as required by the current and past building codes.

References: *R404.1.6 Height above finished grade.*

Concrete and masonry foundation walls shall extend above the finished grade adjacent to the foundation at all points a minimum of 4 inches (102 mm) where masonry veneer is used and a minimum of 6 inches (152 mm) elsewhere.

The minimum distance above adjacent grade to which the foundation must be extended provides termite protection and minimizes the chance of decay resulting from moisture migrating to the wood framing. A reduced foundation extension is permitted when masonry veneer is used. From the Commentary to the IRC.

II. ELECTRICAL SYSTEMS



A. Service Entrance and Panels

Comments:

Items noted during the visual inspection that were deemed deficient, are in need of repair, adjustment, restoration, that require comment, continuation of the due diligence process and/or servicing or items noted for information include but are not limited to:

Information: Electricity was provided to the house by overhead conductors. The conductors had adequate clearance above the ground surface, the insulation appeared to be in good condition and the drip loops were

I=Inspected

NI=Not Inspected

NP=Not Present

D= Deficiency

I	NI	NP	D
---	----	----	---

properly formed. The meter was securely attached to the structure. The grounding conductor was visible and appeared to be securely fastened to the grounding electrode.

Information: The panel board was located on an upright structure on the right side of the home. The panel board had a 200 Amp main disconnect. The listed information for the box was not visible at the time of the inspection. Due to weather conditions at the time of the inspection, the exterior panel board was not opened for inspection. No further information could safely be provided at the time of the inspection.



The conductors to the sub panel in the garage were Aluminum. The branch circuits into the home were copper.

200 Amp Service /Max Panel Rating Not Listed



I=Inspected

NI=Not Inspected

NP=Not Present

D= Deficiency

I	NI	NP	D
---	----	----	---

Deficiency: The aluminum service entrance current carrying conductors had not been properly treated with an anti-oxidizing compound.

Information: The service entrance conductors between the meter and the breaker panel were aluminum conductors, as are almost all service conductors throughout this area. The aluminum conductors should be cleaned and treated with an anti oxidizing compound. Electricity tends to flow on the surface of a conductor and aluminum oxide is a worse conductor than aluminum. The presence of aluminum oxide increases the resistance of the conductor, which increases the heat in the conductor and forces an increase in electrical flow in order to maintain the electrical service, all of which increases electrical use and your cost for electricity. While the metals used for the connectors for the panel are compatible for use with aluminum wiring as far as thermal expansion is concerned, the possibility of galvanic action remains. The anti oxidizing mastic should be replaced as it dissipates.

References: It is very important to use an approved oxide-inhibiting compound on aluminum conductors. Where aluminum conductors are subject to moisture or even very high humidity, oxidation can occur. Oxidation of aluminum can cause a thin film or layer, which looks like a powder, on the conductor. It will result in heat build-up by impeding the current flow. From the Commentary to the IRC.

Deficiency: The grounding electrodes were not fully buried into the ground.

Information: The grounding rod is required to be buried its full length into the earth. The connection of the grounding electrode to the grounding conductor and the grounding conductor itself should be protected from physical damage.

References: E3508.2.2 Installation.

The electrode shall be installed such that at least 8 feet (2438 mm) of length is in contact with the soil. It shall be driven to a depth of not less than 8 feet (2438 mm) except that, where rock bottom is encountered, the electrode shall be driven at an oblique angle not to exceed 45 degrees from the vertical or shall be buried in a trench that is at least 2.5 feet (762 mm) deep. The upper end of the electrode shall be flush with or below ground level unless the aboveground end and the grounding electrode conductor attachment are protected against physical damage.

Deficiency: The bonding of all the electrical systems, metal piping and low voltage systems was not verified.

Information: An intersystem bonding termination bar was installed on the grounding conductor but was not used. The bonds should be made at the termination bar so that the proper bonding of all the required systems can be verified.

References: Article 100 Definitions of the National Electric Code

Intersystem Bonding Termination. A device that provides a means for connecting communication system(s) grounding conductor(s) and bonding conductor(s) at the service equipment or at the disconnecting means for buildings or structures supplied by a feeder or branch circuit.

This definition is new for the 2008 Code. An intersystem bonding termination provides a convenient means to comply with the requirements related to intersystem bonding and grounding of communication systems. It is a dedicated and well-defined location for terminating the grounding conductors required in Chapter 8 and 770.93. The termination would have sufficient capacity to handle multiple communication systems (telecom, satellite, CATV) on premises. Intersystem bonding accomplished by connection of a communication grounding conductor to the power system is an important safety measure to prevent occurrences of voltages

I=Inspected

NI=Not Inspected

NP=Not Present

D= Deficiency

I	NI	NP	D
---	----	----	---

between the communication system and the power system. Frequently, in new construction, the grounding electrode, the raceway, and the grounding electrode conductor are hidden behind walls and are not accessible for bonding connection. The intersystem bonding termination device is intended to provide a means of connecting these grounding conductors to the service, building, or structure grounding electrode system. See Exhibit 250.41 for an example of a device used to provide intersystem bonding. From the Handbook to the National Electric Code.

Deficiency: An improperly sized breaker was observed. For example: The breakers for the upper air conditioning condensing unit, if correctly labeled, were oversized.

Information: The name plate on the unit allows a maximum over current protective device of 35 Amps. The air conditioning condensing unit was connected to breakers that allowed more than 35 amperes on the circuit. The purpose of the breaker is to provide protection to the conductors. The appliance, however, must be installed according to its approval or listing. The minimum circuit capacity and maximum over current protection are listed on the manufacturer’s name plate. Over sizing is not allowed as the appliance could burn and the breakers will not necessarily trip. Installing a larger breaker makes the appliance “unlisted” and the air conditioner is no longer considered to be a safe appliance.

References: E4001.4 Overcurrent protection. Each appliance shall be protected against overcurrent in accordance with the rating of the appliance and its listing.

Deficiency: There were an inadequate number of arc-fault protected circuits installed in the panel.

Information: The requirement for the installation of arc-fault protective devices began with the requirement for the use of arc fault protected outlets in the bedrooms only. This requirement was introduced with the publication of the 1999 National Electric Code (NEC). Arc fault circuit protection is required by the National Electric Code in all areas listed in the reference below. Arc-fault devices monitor the electrical current wave. If the wave pattern changes, indicating a spark or fire, the arc-fault protective device turns the electricity off. This deprives the fire of fuel which, hopefully, extinguishes the fire. It is hoped that the deprivation of fuel will cause the fire to extinguish itself. This information is provided to advise you that these safety devices are available should you want them installed in your home.

Reference: 210.12 Arc-Fault Circuit-Interrupter Protection

Arc-fault circuit-interrupter protection shall be provided as required in 210.12(A) (B), and (C). The arc-fault circuit interrupter shall be installed in a readily accessible location. (A) Dwelling Units. All 120-volt, single-phase, 15- and 20-ampere branch circuits supplying outlets or devices installed in dwelling unit kitchens, family rooms, dining rooms, living rooms, parlors, libraries, dens, bedrooms, sunrooms, recreation rooms, closets, hallways, laundry areas, or similar rooms or areas shall be protected by any of the means described in 210.12(A) (1) through (6): (1)

■ □ □ ■ **B. Branch Circuits, Connected Devices, and Fixtures**

Type of Wiring: Copper

Comments:

Items noted during the visual inspection that were deemed deficient, are in need of repair, adjustment, restoration, that require comment, continuation of the due diligence process and/or servicing or items noted for information include but are not limited to:

Deficiency: The electrical bonding system installed in the house did not appear to include all required components.

Information: All metal piping systems, including each section of the natural gas distribution pipes are

I=Inspected

NI=Not Inspected

NP=Not Present

D= Deficiency

I	NI	NP	D
---	----	----	---

required to be bonded to the breaker panel or grounding electrode to equalize the differing electrical potentials on all elements that are capable of carrying electricity. These systems also include the telecommunications systems, cable systems and satellite systems, etc. Without proper bonding, a person or a flammable item could be the medium through which the potentials are equalized, which could result in a shock, electrocution and/or fire. Proper bonding should be installed for safety.

References: E3509.6 Metal water piping bonding.

The interior metal water piping system shall be bonded to the service equipment enclosure, the grounded conductor at the service, the grounding electrode conductor where of sufficient size, or to the one or more grounding electrodes used. The bonding jumper shall be sized in accordance with Table E3503.1. The points of attachment of the bonding jumper(s) shall be accessible.

E3509.7 Bonding other metal piping.

Where installed in or attached to a building or structure, metal piping systems, including gas piping, capable of becoming energized shall be bonded to the service equipment enclosure, the grounded conductor at the service, the grounding electrode conductor where of sufficient size, or to the one or more grounding electrodes used. The bonding jumper shall be sized in accordance with Table E3808.12 using the rating of the circuit capable of energizing the piping. The equipment grounding conductor for the circuit that is capable of energizing the piping shall be permitted to serve as the bonding means. The points of attachment of the bonding jumper(s) shall be accessible.

Communications systems, cable TV, and similar systems must be grounded. If the enclosures, raceways, and non-current carrying metal surfaces of these other systems are not bonded to the premises wiring system, they could operate at a difference in potential. Intersystem bonding is required to reduce the shock hazard and minimize the possible fire danger. Where the service equipment cabinet and meter base are flush with a brick or stucco wall, the raceways are concealed within the wall, the grounding electrode conductor is not accessible, and the ground rod has been buried, there is nothing available to which to bond the metallic jacket of the communications cable. If the installer drives a separate ground rod to bond the cable TV cable shield and boxes to, it would be a code violation if not bonded to the service electrode system. An accessible means external to the service equipment enclosures must be provided. If the underground service lateral is run in metal conduit installed on the surface of the wall from the ground up, or if the overhead service riser is external, which it most often is, or if the grounding electrode conductor is run to a ground rod along the outside wall, these would be accessible means for intersystem bonding. In some cases, especially where the service equipment is flush with the wall, it may be necessary to bond a size 6 AWG bare copper conductor to the enclosure and leave several inches of the conductor outside the equipment so that it is accessible for the connection of bonding jumpers of other systems. From the Commentary to the IRC.

Deficiency: The CSST (Corrugated Stainless Steel Tubing) flexible gas connectors to the gas fired appliances were not observed to be electrically grounded/bonded the full length of the gas line per the manufacturer.

Information: There has been litigation with CSST gas lines caused by fires/lightning. Even if properly bonded the manufacturer does not warrant that the material will perform if lightning strikes directly on or near a structure. Refer to the manufacturer installation instructions and any "Google" articles on CSST litigation and for news articles on CSST. All metal components must be properly bonded and grounded for safety. All CSST should be replaced with a different flexible gas pipe connector in my opinion.

Reference: Typical Manufacturer's Installation Instructions

I=Inspected

NI=Not Inspected

NP=Not Present

D= Deficiency

I NI NP D

ELECTRICAL BONDING

In accordance with the NFPA 54 Section 7.13, Tru-Flex Metal Hose Corp., requires proper bonding of the Pro-Flex® gas-piping systems in a structure to the structure's electrical grounding system. This must be performed by a qualified person recognized by the local jurisdiction as capable of performing such work. These requirements are for all Pro-Flex® CSST installations.

Direct bonding of Pro-Flex® CSST is required as part of the installation of all new CSST natural and LP gas piping systems whether or not the connected gas equipment is electrically powered. This requirement is provided as part of the manufacturer's instructions for single-family and multi-family dwellings. Bonding for commercial applications should be designed by qualified persons knowledgeable in electrical system design and the local electrical code.

Pro-Flex® CSST installed inside or attached to the exterior of a building structure shall be electrically continuous and direct bonded to an effective ground-fault current path. The gas piping systems shall be considered to be direct bonded when installed in accordance with the following guidelines:

- A bonding jumper is permanently and directly connected to the electrical service grounding system. This can be achieved through a connection to the electrical service equipment enclosure, the grounded conductor at the electrical service, the grounding electrode conductor (where of sufficient size) or to the one or more grounding electrodes used.
- A single bond connection is made to the building gas piping downstream of the utility meter or second stage regulator (LP systems), but near the gas service entrance of the structure, or downstream of the gas meter of each individual housing unit within a multi-family structure. (A bonding connection shall not be made to the underground, natural gas utility service line or the underground supply line from a LP storage tank)
- The bonding conductor shall be no smaller than a 6 AWG copper wire or equivalent. Bonding/grounding clamps shall be attached in an approved manner in accordance with NEC and the listing of the clamp. Bonding /grounding clamps shall be listed to UL 467. The point of attachment for the bonding conductor shall be accessible. This bond is in addition to any other bonding requirements as specified by local codes.
- For attachment to the CSST gas piping system, a single bonding clamp must be attached to either a Pro-Flex® brass fitting, a steel manifold or to any rigid pipe between the meter and the first CSST fitting in the system. *The corrugated stainless steel tubing portion of the gas piping system shall not be used as the point of attachment of the bonding conductor at any location along its length under any circumstances. See drawings 1,2 and 3.*

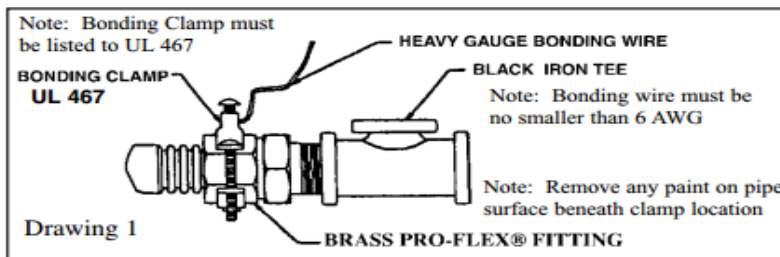

28

I=Inspected

NI=Not Inspected

NP=Not Present

D= Deficiency

I	NI	NP	D
---	----	----	---

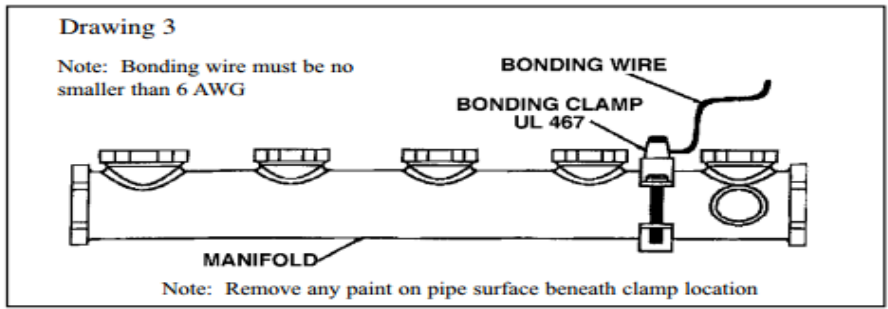
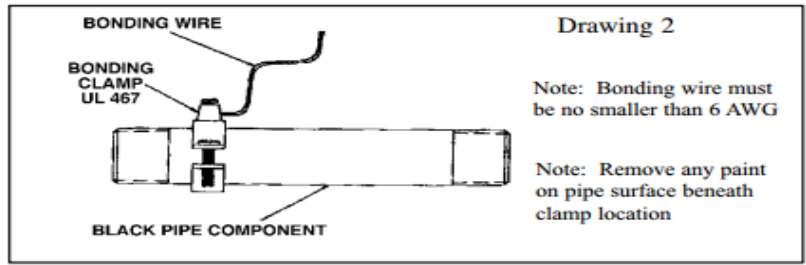

Proper bonding and grounding may reduce the risk of damage and fire from lightning strikes. Lightning is a highly destructive force. Even a nearby lightning strike that does not strike a structure directly can cause metallic systems (such as wiring, piping and ductwork) in the structure to become energized. If these systems are not properly bonded, the difference in potential between the systems may cause the charge to arc from one system to another and cause damage to the CSST. Bonding instructions set forth above should reduce the risk of arcing and its related damages.

Depending upon conditions specific to the location of the structure in which the Pro-Flex® system is being installed, including but not limited to whether the area is prone to lightning activity, the owner of the structure should consider whether a lightning protection system is necessary or appropriate. Lightning protection systems are beyond the scope of this manual, but are covered by NFPA 780, the Standard for the Installation of Lightning Protection Systems, and other standards.

As with all Pro-Flex® guidelines, the techniques outlined within this manual/bulletin are subject to all local fuel gas and building codes.

***LIGHTNING SAFTY WARNING**

PROPERLY BONDING and grounding the Corrugated Stainless Steel Tubing (CSST) system may reduce the risk of damage and fire from lightning strike. Lightning is a highly destructive force. Even a nearby lightning strike that does not strike a structure directly can cause systems in the structure to become electronically energized. Differences in potential between systems may cause the charge to arc between systems. Such arching can cause damage to CSST, including holes. Bonding should reduce the risk of arching and related damage.

I=Inspected

NI=Not Inspected

NP=Not Present

D= Deficiency

I	NI	NP	D
---	----	----	---

Deficiency: Exposed wiring was observed on the right exterior of the home.



Information: All wiring junctions should be properly sealed in closed junction boxes. Open wiring junctions and junction boxes are considered to be a fire hazard. This is an unsafe condition. All unsafe conditions should be remedied.

References: *E3805.1 Box, conduit body or fitting where required.*

A box or conduit body shall be installed at each conductor splice point, outlet, switch point, junction point and pull point except as otherwise permitted in Sections E3805.1.1 through E3805.1.7. Fittings and connectors shall be used only with the specific wiring methods for which they are designed and listed.

The point in the wiring system that is the most vulnerable for possible problems due to overheating caused by arcing or sparking is a splice or connection. Except for some cases of underground wiring, a box or enclosure must always be used to make a splice or connection. Some individuals may believe that if the splice has plenty of tape, is not against a stud or joist, and is supported in air, it will be fine. A splice or connection made outside of a box is a violation and a serious safety concern. Nonmetallic sheathed cable must be used in continuous lengths from box to box. There must be no splices, and the box must be accessible. From the commentary to the IRC.

Deficiency: There was inadequate clearance in front of the air conditioning mechanic's disconnects at the air conditioning condensing units.

Information: All energized electrical equipment and panelboards are required to have unobstructed access 36 inches deep in front of the equipment and 30 inches wide, at a minimum. Proper access for the mechanic's disconnects should be provided according to Section E3305.2 of the IRC and Section 110.26(A) of the National Electric Code.

References: *From the National Electric Code*

The intent of 110.26(A) is to provide enough space for personnel to perform any of the operations listed without jeopardizing worker safety. Examples of such equipment include panelboards, switches, circuit breakers, controllers and controls on heating and air conditioning equipment. It is important to understand that the word examination includes such tasks as checking for voltage with a portable voltmeter. 110.26(A) NEC.

I=Inspected

NI=Not Inspected

NP=Not Present

D= Deficiency

I	NI	NP	D
---	----	----	---

Deficiency: Some of the lighting fixtures did not operate.

Information: This may be caused by burned out light bulbs however; the inspector could not make this determination. The fixtures should be made operable.

Deficiency: In my opinion, considerations should be made in regard to safety regarding the fixture above the master bathroom tub to the top of the bathtub rim.

Information: The fixture above the tub in the master bathroom may pose a hazard. Please review the requirements of the National Electric Code (NEC) for safety purposes.

Reference: *NEC 410.10 Luminaires in Specific Locations.*

(D) Bathtub and Shower Areas. No parts of cord- connected luminaires, chain-, cable-, or cord-suspended luminaires, lighting track, pendants, or ceiling-suspended (paddle) fans shall be located within a zone measured 900 mm (3 ft) horizontally and 2.5 m (8 ft) vertically from the top of the bathtub rim or shower stall threshold. This zone is all encompassing and includes the space directly over the tub or shower stall. Luminaires located within the actual outside dimension of the bathtub or shower to a height of 2.5 m (8 ft) vertically from the top of the bathtub rim or shower threshold shall be marked for damp locations, or marked for wet locations where subject to shower spray.

Deficiency: All electrical outlets in “wet” locations were not protected by Ground Fault Circuit Interrupter devices (GFCIs). (i.e. exterior of the home, etc.)

Information: Wet locations are defined, by the 1996 National Electric Code, as any counter outlet in the kitchen, any outlet in a bathroom, garage, exterior, wiring to a whirlpool bath or Jacuzzi or to swimming pools, hot tubs or spas. Wet locations are basically any area where you and the electrical device you are using are likely to come into contact with water. GFCIs became part of the code in the mid 1980's and locations they are required in are constantly being added. The lack of GFCIs is considered to be an unsafe condition. All unsafe conditions should be properly repaired.

References: *Section 3902 of the IRC.*

E3902.1 Bathroom receptacles, E3902.2 Garage and accessory building receptacles, E3902.3 Outdoor receptacles, E3902.4 Crawl space receptacles, E3902.5 Unfinished basement receptacles, E3902.6 Kitchen receptacles, E3902.7 Sink receptacles, E3902.8 Boathouse receptacles, E3902.9 Boat hoists and E3902.10 Electrically heated floors.

Deficiency: An electrical outlet under the kitchen sink was installed in the face-up position.

I=Inspected

NI=Not Inspected

NP=Not Present

D= Deficiency

I	NI	NP	D
---	----	----	---



Information: The National Electric Code and the IRC prohibit the installation of electrical receptacles in the face up position on kitchen and bathroom counter tops to prevent debris and water from entering the receptacle. While the installation of the receptacle in the face-up position under the kitchen sink may not violate the exact provisions of the codes, it violates the intent of the codes in my opinion. It is my opinion that the receptacle should be moved to the side wall to reduce the possibility of water or debris entering the receptacle.

E3801.4.5 Receptacle outlet location.

Receptacle outlets shall be located not more than 20 inches (508 mm) above the countertop. Receptacle outlets shall not be installed in a face-up position in the work surfaces or countertops. Receptacle outlets rendered not readily accessible by appliances fastened in place or appliances occupying dedicated space shall not be considered as these required outlets.

Deficiency: Electrical outlet box extenders were not installed on electrical wall outlets and lighting switch outlet boxes installed through additional wall covering surfaces in the kitchen and bathrooms, etc.

Information: The electrical outlet boxes were fastened to the wall framing and there are spaces existing between the front of the outlet box and the cover plate. When outlet boxes and switch boxes are installed through additional wall covering materials, such as tile or cultured marble, etc. an outlet box extender is required to be installed to seal the opening between the outlet box and the cover plate. See section E3806.5 of the International Residential Code.

References: E3806.5 In wall or ceiling.

In walls or ceilings of concrete, tile or other noncombustible material, boxes shall be installed so that the front edge of the box will not be set back from the finished surface more than 0.25 inch (6.4 mm). In walls and ceilings constructed of wood or other combustible material, outlet boxes shall be flush with the finished surface or project therefrom.

Deficiency: There were an inadequate number of wall outlets by current standards.

Information: Wall outlets are currently required to be installed not farther than 12 feet apart as measured along the wall and on any wall section wider than 2 feet. Electrical wall outlets cannot be more than 4 feet apart on kitchen counters. The reason for the rule is to attempt to prevent the home owner or occupant from using extension cords.

I=Inspected

NI=Not Inspected

NP=Not Present

D= Deficiency

I	NI	NP	D
---	----	----	---

Reference: E3801.2.1 Spacing.

Receptacles shall be installed so that no point measured horizontally along the floor line in any wall space is more than 6 feet (1829 mm), from a receptacle outlet.

This requirement is intended to eliminate the need for extension cords. In any of the rooms listed (or a similar area of a dwelling), a lamp, appliance, radio, TV, or other electrical appliance can be placed at any point along the floor line, and a receptacle will be available within 6 feet of that location. It is important to not "cut corners" when measuring. The floor line is measured along the wall all the way into and around corners. Where a door opens against a wall, it may seem reasonable to begin the measurement at the end of the door swing, about 30 to 36 inches (762 to 914 mm) from the hinged side of the door casing, but the code requires that the wall space be counted all the way to the door jamb. From the Commentary to the IRC.

Deficiency: A cracked cover plate was noted in the lower cabinet to the right of the refrigerator in the Kitchen.

Information: Cover plates on electrical boxes are provided for safety. They conceal live electrical components, protect the live electrical components from flammable materials and prevent people from coming in contact with live electrical components. The cover plate should be replaced for safety.

NOTICE: Arc Fault Circuit Interrupters are required on all electrical wall outlets. Appliances with motors, such as your refrigerator freezer, dishwasher, disposer, a freezer or garage door operators, etc. may cause the Arc Fault Circuit Interrupters to trip. This will cause the appliance to stop operating.

Information: Arc Fault Circuit Interrupters are fire suppressive devices that have been found to be of great benefit in reducing the number of house fires. However, Arc Fault Circuit Interrupters cause a great deal of nuisance tripping which causes the occupant of the house to have to reset the Arc Fault Circuit Interrupting breaker in the breaker panel. Arc Fault Circuit Interrupters tripping when attached to a refrigerator can cause the food in the refrigerator to spoil. Arc Fault Circuit Interrupters tripping can also cause you to be locked out of your house if the garage door operator circuit breaker trips.

Reference: 210.12 Arc-Fault Circuit-Interrupter Protection of the 2014 National Electric Code

Arc-fault circuit-interrupter protection shall be provided as required in 210.12 (A) (B), and (C). The arc-fault circuit interrupter shall be installed in a readily accessible location.

(A) Dwelling Units. All 120-volt, single-phase, 15- and 20-ampere branch circuits supplying outlets or devices installed in dwelling unit kitchens, family rooms, dining rooms, living rooms, parlors, libraries, dens, bedrooms, sunrooms, recreation rooms, closets, hallways, laundry areas, or similar rooms or areas shall be protected by any of the means described in 210.12(A) (1) through (6):

(1) A listed combination-type arc-fault circuit interrupter, installed to provide protection of the entire branch circuit

(2) A listed branch/feeder-type AFCI installed at the origin of the branch-circuit in combination with a listed outlet branch-circuit type arc-fault circuit interrupter installed at the first outlet box on the branch circuit. The first outlet box in the branch circuit shall be marked to indicate that it is the first outlet of the circuit.

(3) A listed supplemental arc protection circuit breaker installed at the origin of the branch circuit in combination with a listed outlet branch-circuit type arc-fault circuit interrupter installed at the first outlet box on the branch circuit where all of the following conditions are met:

a. The branch-circuit wiring shall be continuous from the branch-circuit overcurrent device to the outlet branch circuit arc-fault circuit interrupter.

I=Inspected

NI=Not Inspected

NP=Not Present

D= Deficiency

I	NI	NP	D
---	----	----	---

b. The maximum length of the branch-circuit wiring from the branch-circuit overcurrent device to the first outlet shall not exceed 15.2 m (50 ft) for a 14 AWG conductor or 21.3 m (70 ft) for a 12 AWG conductor.

c. The first outlet box in the branch circuit shall be marked to indicate that it is the first outlet of the circuit.

(4) A listed outlet branch-circuit type arc-fault circuit interrupter installed at the first outlet on the branch circuit in combination with a listed branch-circuit overcurrent protective device where all of the following conditions are met:

a. The branch-circuit wiring shall be continuous from the branch-circuit overcurrent device to the outlet branch circuit arc-fault circuit interrupter.

b. The maximum length of the branch-circuit wiring from the branch-circuit overcurrent device to the first outlet shall not exceed 15.2 m (50 ft) for a 14 AWG conductor or 21.3 m (70 ft) for a 12 AWG conductor.

c. The first outlet box in the branch circuit shall be marked to indicate that it is the first outlet of the circuit.

d. The combination of the branch-circuit overcurrent device and outlet branch-circuit AFCI shall be identified as meeting the requirements for a system combination-type AFCI and shall be listed as such.

(5) If RMC, IMC, EMT, Type MC, or steel-armored Type AC cables meeting the requirements of 250.118, metal wireways, metal auxiliary gutters, and metal outlet and junction boxes are installed for the portion of the branch circuit between the branch-circuit overcurrent device and the first outlet, it shall be permitted to install a listed outlet branch circuit type AFCI at the first outlet to provide protection for the remaining portion of the branch circuit.

(6) Where a listed metal or nonmetallic conduit or tubing or Type MC cable is encased in not less than 50 mm (2 in.) of concrete for the portion of the branch circuit between the branch-circuit overcurrent device and the first outlet, it shall be permitted to install a listed outlet branch-circuit type AFCI at the first outlet to provide protection for the remaining portion of the branch circuit.

Notice: The National Electric Code (NEC) has required the installation of Arc Fault Circuit Interrupting (AFCI) Breakers on 120 volt circuits since the late 1990's. AFCI breakers were originally required on all bedroom receptacles. Bedroom receptacles include lighting fixtures, ceiling fans and smoke alarms along with electrical wall outlets. Under current codes, AFCIs are required on all 120 volt circuits that do not permanently supply an appliance or on electrical circuits that have Ground Fault Circuit Interrupting (GFCI) protection. The purpose of an AFCI is to turn the electricity off on an electrical circuit when a spark, arc or electrical fire is found in an electrical circuit. The spark or arc is noted by a change in the electrical current flow. AFCIs commonly trip when an appliance is connected to the circuit as a spark often occurs when the appliance is plugged into the wall outlet. Nuisance tripping is a random occurrence that is not discoverable in the course of a one-time visual inspection of a property. If excessive nuisance tripping of an AFCI device is noted please contact a licensed, competent electrician. During an inspection of an occupied house AFCIs cannot not be tested due to the possibility of damaging electrical appliances that are connected to an AFCI breaker. As there are no completely accurate testing devices available, AFCIs are tested in unoccupied houses by pressing the "test" button on the AFCI breaker only.

Deficiency: The toggle switch controlling the attic lighting fixtures were not identified.

Information: All electrical control devices are required to be identified unless the purpose of the control device is clear. The toggle switch should be labeled to prevent the lighting fixture from being left on.

I=Inspected

NI=Not Inspected

NP=Not Present

D= Deficiency

I	NI	NP	D
---	----	----	---

Deficiency: There was no mechanic’s disconnect at the electric heater.

Information: The mechanic’s disconnect is for the safety of the technician, or mechanic, who is servicing the unit. All appliances are required to have a mechanic’s disconnect so that the electrical current can be turned off by a technician who is working on the unit. A mechanic’s disconnect should be installed for safety.

Deficiency: Smoke alarms were not located in all areas currently required and considered necessary for safety. Smoke detectors were observed on the 4th floor or in the downstairs bedroom.

Information: Smoke alarms are required to be located in each sleeping room, outside of each sleeping area and on each story of the structure, at a minimum.

Reference: R314.3 Location.

Smoke alarms shall be installed in the following locations:

1. In each sleeping room.
2. Outside each separate sleeping area in the immediate vicinity of the bedrooms.
3. On each additional story of the dwelling, including basements and habitable attics but not including crawl spaces and uninhabitable attics. In dwellings or dwelling units with split levels and without an intervening door between the adjacent levels, a smoke alarm installed on the upper level shall suffice for the adjacent lower level provided that the lower level is less than one full story below the upper level.

Notice: The inter-connectivity of the smoke alarms could not be verified.

Information: The smoke alarms must be inter-connected so that when one alarm is activated, all alarms sound. The inter-connectivity should be verified or the smoke alarms must be inter-connected prior to the expiration of any due diligence investigation period limitation.

Deficiency: No carbon monoxide detector was noted inside the house.

Information: Carbon monoxide detectors are required for safety. A carbon monoxide detector should be installed and connected to all the alarms for safety.

III. HEATING, VENTILATION AND AIR CONDITIONING SYSTEMS

■ □ □ ■

A. Heating Equipment

Type of Systems: Central Forced

Energy Sources: Natural Gas (Upper Attic) and Electricity (Ground Floor)

Comments:

Items noted during the visual inspection that were deemed deficient, are in need of repair, adjustment, restoration, that require comment, continuation of the due diligence process and/or servicing or items noted for information include but are not limited to:

I=Inspected

NI=Not Inspected

NP=Not Present

D= Deficiency

I	NI	NP	D
---	----	----	---



Deficiency: The upper furnace had not been placed into service at the time of the inspection.



Information: The unit should be placed into service and tested for proper and safe operation prior to the termination of any due diligence investigation period.

Deficiency: The cover panel was missing for the downstairs electric heater.

Information: The missing cover panel should be replaced for proper operation of the system and equipment.

I=Inspected

NI=Not Inspected

NP=Not Present

D= Deficiency

I	NI	NP	D
---	----	----	---

NOTICE: The types of furnace installed do not lend themselves to a visual inspection of the heat exchangers.

Information: The seams and body of the heat exchanger is concealed from view. In order to inspect the heat exchangers, the units must be disassembled, which is beyond the scope of this inspection. There is no visual test to determine the condition of these heat exchangers. A competent HVAC contractor should be contacted to make an inspection of the heat exchangers prior to expiration of any due diligence investigation period.

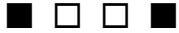

B. Cooling Equipment

Type of Systems: Central Split

Comments: Electricity

Items noted during the visual inspection that were deemed deficient, are in need of repair, adjustment, restoration, that require comment, continuation of the due diligence process and/or servicing or items noted for information include but are not limited to:





I=Inspected

NI=Not Inspected

NP=Not Present

D= Deficiency

I NI NP D

SERIAL		1515E03112	
PROD	24ACC448A0030010		
MODEL	24ACC448A300		
METERING	TXU	NA	
DEVICE	INDOOR	OUTDOOR	
FACTORY CHARGED	R410A		
	8.31 LBS	3.77 KG	
INDOOR TXU SUB COOLING	11 °F		
POWER SUPPLY	208-230	VOLTS AC	
	1 PH	60 HZ	
PERMISSIBLE VOLTAGE AT UNIT			
	253 MAX	197 MIN	
SUITABLE FOR OUTDOOR USE			
COMPRESSOR	208/230	VOLTS AC	
	1 PH	60 HZ	
	15.5 RLA	105.5 LRA	
FAN MOTOR	208/230	VOLTS AC	
	1 PH	60 HZ	
	1/4 HP	1.40 FLA	
DESIGN/TEST PRESSURE GAGE			
HI	450 PSI	3103	KPA
LO	250 PSI	1724	KPA
MAX DESIGN/WORKING PRESSURE			
	700 PSIG	4826 KPA	
MINIMUM CIRCUIT AMPS			
	20.8		
MAX FUSE	MAX CKT-BKR(*)		35 A
	35 A		
Short Circuit Current:5kA rms.symmetrical, 230 U			
 MODEL NUMBER 24ACC448A0030010			
 SERIAL NUMBER 1515E03112 DATE OF MANUFACTURE APR 2015			
 CENTRAL COOLING AIR CONDITIONER 3R39			
 Unitary Small AC AHRI Standard 210/240 Certification applies only when the complete system is listed with AHRI.			
Carrier Corporation 7310 West Morris St. Indianapolis, IN 46231			
341020-4006 Installation Prohibited in Southwest			

I=Inspected

NI=Not Inspected

NP=Not Present

D= Deficiency

I	NI	NP	D
---	----	----	---

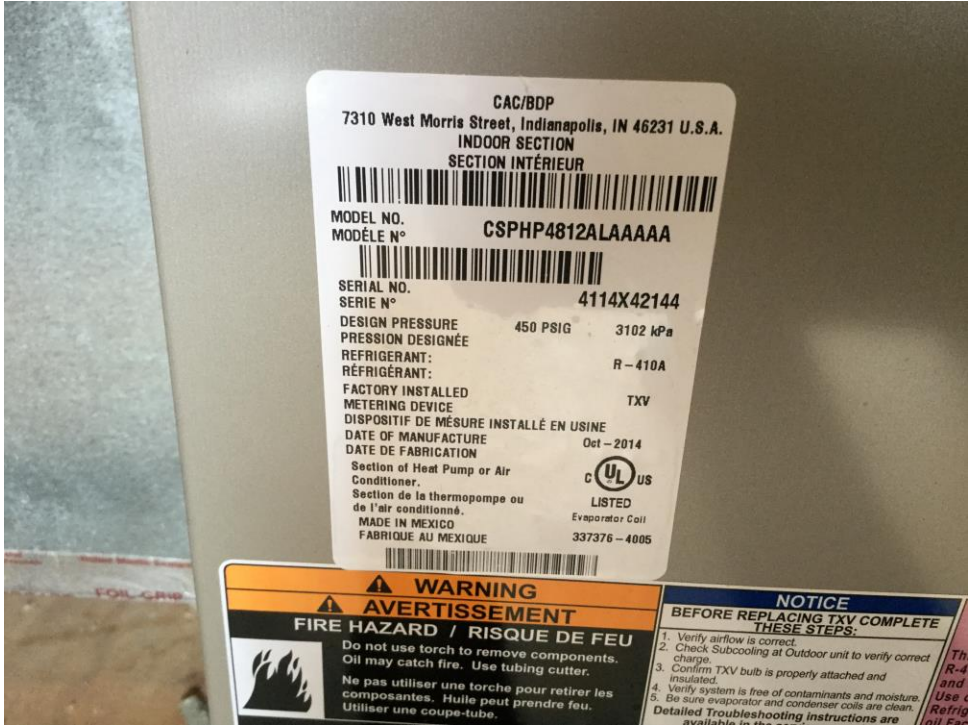





I=Inspected

NI=Not Inspected

NP=Not Present

D= Deficiency

I NI NP D

SERIAL		1615E25141	
PROD	24ACC424A0030010		
MODEL	24ACC424A300		
METERING	TXU	NA	
DEVICE	INDOOR	OUTDOOR	
FACTORY CHARGED	R410A		
	3.87 LBS	1.76 KG	
INDOOR TXU SUB COOLING	10 °F		
POWER SUPPLY	208-230	VOLTS AC	
	1	PH	60 HZ
PERMISSIBLE VOLTAGE AT UNIT			
	253	MAX	197 MIN
SUITABLE FOR OUTDOOR USE			
COMPRESSOR	208/230	VOLTS AC	
	1	PH	60 HZ
	10.9	RLA	62.9 LRA
FAN MOTOR	208/230	VOLTS AC	
	1	PH	60 HZ
	1/12	HP	0.50 FLA
DESIGN/TEST PRESSURE GAGE			
HI	450	PSI	3103 KPA
LO	250	PSI	1724 KPA
MAX DESIGN/WORKING PRESSURE			
	700	PSIG	4826 KPA
MINIMUM CIRCUIT AMPS			
	14.1		
MAX FUSE	MAX CKT-BKR(*)		
20 A	20 A		
Short Circuit Current:5kA rms,symmetrical, 230 U			
 MODEL NUMBER 24ACC424A0030010			
 SERIAL NUMBER 1615E25141 DATE OF MANUFACTURE APR 2015			
 US LISTED CENTRAL COOLING AIR CONDITIONER 3R39			
 AHRI CERTIFIED™ WWW.AHRIDIRECTORY.ORG Unitary Small AC AHRI Standard 210/240 Certification applies only when the complete system is listed with AHRI.			
Carrier Corporation 7310 West Morris St. Indianapolis, IN 46231 341020-4002			
Installation Prohibited in Southwest			

I=Inspected

NI=Not Inspected

NP=Not Present

D= Deficiency

I NI NP D

Deficiency: The cover panel was missing for the interior downstairs equipment.

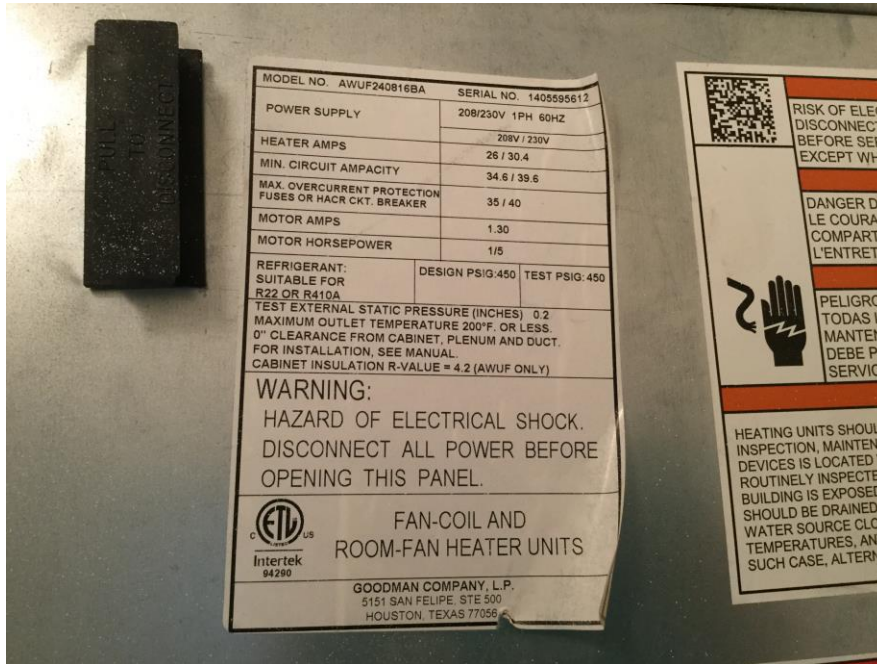

Information: The missing cover panel should be replaced for proper operation of the system and equipment.

Deficiency: The downstairs condensing unit and the evaporator coil were manufactured by different companies.

Information: This often causes the system to lose efficiency in operation. Some manufacturers will void their warranties if evaporator coils made by another company are used with their condensing coils. It should be verified that the condensing coil and the evaporator coil function properly and efficiently together and that all manufacturer's warranties are in force.

Deficiency: The downstairs evaporator coil and the condensing coil may not be compatibly sized, if the model numbers of the units were correctly interpreted.

Information: The evaporator coil appeared to be rated at five tons and the condensing coil appeared to be rated at four tons. If the sizing is correctly understood, the evaporator coil would be capable of absorbing more heat than the condensing coil can discharge. This may reduce the efficiency of the system and may shorten the life expectancies of the units. Some manufacturers disclaim this type of installation completely while some manufacturers will allow a one half ton difference in sizing. These manufacturers void their warranties if the units are not compatibly sized. It should be determined that the units will function together properly and that the units are under the manufacturer's warranty prior to the expiration of any due diligence investigation period.

Deficiency: The primary condensate drain pipe for the downstairs evaporator coil terminated on the side of the house.

Information: Current codes provide that the primary condensate drain terminate in an active use trap, such as under a bathroom lavatory. Terminating the primary condensate drain pipe on the side of the house can cause

I=Inspected

NI=Not Inspected

NP=Not Present

D= Deficiency

I	NI	NP	D
---	----	----	---

differential foundation movements, can attract wood destroying and other insects and pests and can cause water damage to the veneer. The termination of the primary drain pipe should be relocated either well away from the side of the house or at an actively used trap.

Deficiency: The temperature drops measured across the evaporator coils for both systems was inadequate.

Information: The drop should be in the range of 16 to 20 degrees Fahrenheit. The temperature drop measured across the coils was less than the range noted. This is normally a sign, although not the only reason, that the unit was low on refrigerant, that the system was dirty or that the ducting system did not move air properly. The equipment and possibly the system was in need of service. The refrigerant system should be checked for leaks.

Deficiency: The temperature differences between the various rooms exceeded the four degree variation limit and the relative humidity levels were too high.

Information: The units were on when I arrived at the property. After the units had been in continuous operation for at approximately three hours, the measurements indicated that the temperatures were not uniform from room to room and that the variations exceeded the 4 degree limitation generally allowed. The relative humidity levels were too high throughout the house. The systems should be repaired and adjusted to provide proper air circulation, proper volumes of air flow, uniform room temperatures, lower humidity and cooling comfort.

■ □ □ ■ C. Duct System, Chases, and Vents

Comments:

Items noted during the visual inspection that were deemed deficient, are in need of repair, adjustment, restoration, that require comment, continuation of the due diligence process and/or servicing or items noted for information include but are not limited to:

Deficiency: It appeared as though the only return air opening for the downstairs equipment was the hall closet. In my opinion, the equipment appeared restricted when the door was opened. Further investigation is recommended.

Information: Return air openings should not be obstructed. Although openings were observed in the door, in my opinion, the closed door will deprive the HVAC system of return air. Failure to provide adequate return air prevents the air conditioning and heating systems from operating properly and from operating efficiently. All return air chases should be verified as being at least adequate for each HVAC system.



I=Inspected

NI=Not Inspected

NP=Not Present

D= Deficiency

I	NI	NP	D
---	----	----	---

NOTICE: Return air openings were not installed in the highest points of the ceilings of the four story home. No supply register or return air vent was observed beyond the 3rd story of the home.

Heat rises. Heat and moisture collect on the ceilings unless there are return air openings that involve the heated, moist air into the circulating air system.

Information: Heat rises. The return air openings should be located where the heat is. Most builders and HVAC installers are highly resistant to locating return air openings where they are more visible as home owners object to the unsightly grills. However, the concept of reducing air exchanges with the exterior environment and tightening the house envelop makes proper air circulation, the removal of latent heat and water vapor (humidity) from the interior of the house more critical. Allowing heated air with high water content stagnant on the ceilings greatly increases the probability of molds, increases the latent heat inside the house and increases the relative humidity inside the house. With the smaller, high efficient refrigeration systems (air conditioning) water removal from the air is difficult as the units do not run long enough to remove the water. The higher the relative humidity inside the house, the more you turn the thermostat down as the perspiration on your skin is not evaporating. When your skin is not drying, the components of your house are not drying either. You are strongly advised to have return air openings installed where the heated air collects and from several areas of the house for improved performance of the equipment and system, air circulation, for your comfort and for the performance of your house.

Deficiency: The transition chamber for the upper attic equipment was not sealed and conditioned air was escaping into the attic.

Information: The transition chamber was damaged and should be repaired.

Deficiency: Some of the registers were pointed at the doorway leading to the return air chase instead of at the exterior walls.

Information: For proper air flow and uniform cooling and drying of the air, all of the air space in each of the various rooms must be involved in the circulation pattern. All of the supply registers should be pointed at the exterior walls away from the return air opening for improved air circulation.

Deficiency: Conditioned air distribution was not proper in the house and low air flow was noted at several of the air registers. Some rooms were significantly cooler than others.

Information: The ducting system should be designed to distribute conditioned air in such a manner as to create an air flow system that provides conditioned air to all areas of the house. The volume of air flowing through the cooling equipment should be verified as compatible with the designed air flow of the system. The conditioned air distribution system should be inspected and corrected by a competent HVAC contractor.

Deficiency: The conditioned air distribution systems flexible ducts rested on each other in some areas.

Information: Flexible ducts are not designed to support the weight of another duct. One duct resting on top of another duct can also create zones where condensation can occur. The ducts should be separated, made as straight and tight as possible and the ducts should be properly supported.

I=Inspected

NI=Not Inspected

NP=Not Present

D= Deficiency

I	NI	NP	D
---	----	----	---

IV. PLUMBING SYSTEM

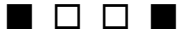

A. Water Supply System and Fixtures

Location of water meter: on the street right of way

Location of main water supply valve: Right Exterior Wall

*Static water pressure reading: **Unable to determine as work in progress on water system***

Comments:

Items noted during the visual inspection that were deemed deficient, are in need of repair, adjustment, restoration, that require comment, continuation of the due diligence process and/or servicing or items noted for information include but are not limited to:

Deficiency: Back flow prevention devices were not installed on all of the exterior faucets.

Information: Back flow prevention devices are required on all exterior faucets to reduce the possibility of contamination of the potable water supply system. It is recommended that they be installed.

Deficiency: CPVC water supply pipes were installed in the hot water system of the house.

Information: There have been recent news articles and reported lawsuits filed over CPVC cracking and leaking starting in the approximate 14th year of use. You should acquaint yourself with this issue to determine if the use of CPVC is acceptable for your use.

Deficiency: There was air in the supply pipes. See notation above regarding work in progress in the area.

Information: As previously noted in this section, work was in progress in the area. Upon completion, the water supply system and fixtures should be tested for operation as part of your due diligence prior to closing.

Deficiency: The vertical water supply pipes at the water heater were not properly supported.

Information: Pipes should be supported to prevent excessive vibration. Vertical sections of pipes should be supported to keep the pipes straight.

Deficiency: The glass enclosure did not retain water inside the master bathroom shower stall during operation.

I=Inspected

NI=Not Inspected

NP=Not Present

D= Deficiency

I	NI	NP	D
---	----	----	---



Information: Water appeared to have flowed out of the shower stall where the ends of the glass panels are caulked against the tile. The enclosure should be properly sealed to prevent leaks.

Deficiency: There were gaps in the caulk at the fixture penetrations in bathrooms. The most notable, in my opinion was in the master bathroom.



Information: The bathtub/tile junctions should be re-caulked.

Deficiency: The tub/shower diverter valves did not work properly or seal at the time of the inspection.

Information: The diverter valves should be repaired or replaced.

Deficiency: The holder for the shower type head / hose at the master tub was not properly secured and this inspector was not able to make the fixture work properly with the diverter at the time of the inspection.

I=Inspected

NI=Not Inspected

NP=Not Present

D= Deficiency

I	NI	NP	D
---	----	----	---

Information: The holder for the head / hose should be properly secured and the fixture put into operation.

Deficiency: CSST gas piping was used on moveable appliances.

Information: CSST is not rated for use on moveable or portable equipment. The CSST gas piping should be replaced with properly rated gas piping.

Reference: *G2414.5.3 (403.5.4) Corrugated stainless steel tubing.*

CSST is allowed by the manufacturers' installation instructions to connect directly to fixed-in- place, non-portable, non-movable appliances such as furnaces, boilers, gas fireplaces and water heaters. CSST is not intended for direct connection to moveable appliances such as clothes dryers or ranges nor is it intended to connect to appliances suspended on chains or rods such as radiant heaters and unit heaters.

Deficiency: The natural gas pipe supply pipe penetration through the outside wall is required to be sleeved so that no friction between the veneer and the gas pipe can develop and so that corrosives from the outside wall cannot attack the gas pipe. The sleeve is also required to protect the pipe should differential foundation movements occur. Corrosion was observed on the piping.



Information: Friction between the outside wall and the pipe can cause the pipe to be damaged. The penetration of the gas pipe through the outside wall should be sleeved for safety.

References: *G2415.7 (404.7) Above-ground piping outdoors.*

All piping installed outdoors shall be elevated not less than 3 1/2 inches (152 mm) above ground and where installed across roof surfaces, shall be elevated not less than 3 1/2 inches (152 mm) above the roof surface. Piping installed above ground, outdoors, and installed across the surface of roofs shall be securely supported and located where it will be protected from physical damage. Where passing through an outside wall, the piping shall also be protected against corrosion by coating or wrapping with an inert material. Where piping is encased in a protective pipe sleeve, the annular space between the piping and the sleeve shall be sealed.

Deficiency: The natural gas distribution pipes were made of galvanized and black iron pipes. Electrolysis / corrosion was noted at the improper connections.

Information: Galvanized and black iron pipes cannot be directly connected as electrolysis will result. Di-anode connectors should be installed at the junctions of the galvanized and black iron pipes or the galvanized pipe sections should be replaced with black iron pipe.

I=Inspected

NI=Not Inspected

NP=Not Present

D= Deficiency

I	NI	NP	D
---	----	----	---

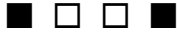

B. Drains, Wastes, and Vents

Comments:

Items noted during the visual inspection that were deemed deficient, are in need of repair, adjustment, restoration, that require comment, continuation of the due diligence process and/or servicing or items noted for information include but are not limited to:

NOTICE: When a house is newly built or remodeled, or when a house has been vacated from even for a short period of time, it is not unusual for the plumbing system to back up when the new owner occupies the structure. This is due to the fact that the contractors building or remodeling the house use the plumbing system as a method of cleaning everything from paint to putty to anything else you can think of. Solids in the pipes tend to congeal as water drains from the pipes through lack of use and the solids can form barriers in the pipes. Before occupying the structure, you should repeatedly fill all plumbing fixture in an attempt to insure that the drains will operate once you and your family have moved into the property.

Deficiency: Some of the tub drain traps and supply systems were not accessible and were not inspected.

Information: An opening is required to be made behind the tub to allow access to the drain pipes and supply system for inspection and service. Without the opening, there is no possibility of determining the condition or the integrity of the tub plumbing. The tub drain systems and the parts, components and systems in the tub enclosure could not be inspected and are specifically excluded from the inspection and from this report.

References: *P2704.1 General.*

Slip joints shall be made with an approved elastomeric gasket and shall be installed only on the trap outlet, trap inlet and within the trap seal. Fixtures with concealed slip-joint connections shall be provided with an access panel or utility space not less than 12 inches (305 mm) in its smallest dimension or other approved arrangement so as to provide access to the slip connections for inspection and repair.

Deficiency: The safety pan beneath the clothes washing machine was damaged.



Information: The damaged pan should be repaired or replaced.

I=Inspected

NI=Not Inspected

NP=Not Present

D= Deficiency

I	NI	NP	D
---	----	----	---

P2706.1 General.

Every waste receptor shall be of an approved type. Plumbing fixtures or other receptors receiving the discharge of indirect waste pipes shall be shaped and have a capacity to prevent splashing or flooding and shall be readily accessible for inspection and cleaning. Waste receptors and standpipes shall be trapped and vented and shall connect to the building drainage system. A removable strainer or basket shall cover the waste outlet of waste receptors. Waste receptors shall be installed in ventilated spaces. Waste receptors shall not be installed in bathrooms or in any inaccessible or unventilated space such as a closet. Ready access shall be provided to waste receptors.

Waste receptors are typically used to receive discharge from fixtures or appliances required to discharge indirectly, such as condensate drains, clothes washers, and dishwashers. These appliances discharge waste either to dedicated waste receptors or to a tailpiece serving other plumbing fixtures. Appliances must be designed and installed to prevent splashing or flooding. They must be located in areas that are readily accessible for monitoring and cleaning; in ventilated spaces; and not in frequently accessed areas, such as closets. The receptor is to be equipped with a strainer unless an open hub receptor is installed at least 1 inch (25.4 mm) above an impervious floor. The receptor, whether independent or part of a fixture connection with the drainage system (e.g. lavatory tailpiece), must be trapped, vented, and connected to the drainage system. See Commentary Figures P2706.1(1), P2706.1(2), and P2706.1(3). From the Commentary to the IRC.

NOTICE: The operation of the laundry room clothes washing machine drain pipe was not verified. The proper operation of the drain pipe and system should be verified prior to the closing on the house.

NOTICE: There was a clothes washing machine was connected and the clothes washing machine faucets and drain could not be operated.

Information: Proper operation and installation of the faucets and drain for the clothes washing machine should be verified prior to the closing on the house.

■ □ □ ■ C. Water Heating Equipment

Energy Sources: Natural Gas

Capacity: 50 Gallons

Comments:

Items noted during the visual inspection that were deemed deficient, are in need of repair, adjustment, restoration, that require comment, continuation of the due diligence process and/or servicing or items noted for information include but are not limited to:

I=Inspected

NI=Not Inspected

NP=Not Present

D= Deficiency

I NI NP D

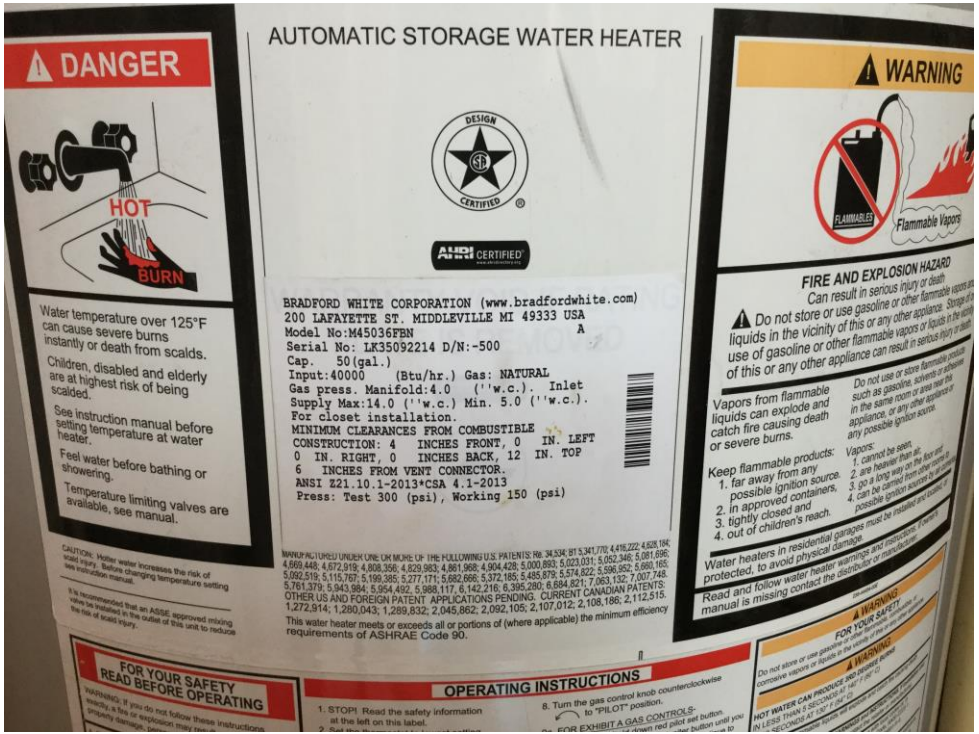

Deficiency: The tank was damaged.

Information: The interior lining of a water heater is usually glass. Rough handling of the tank normally causes the glass to crack. While the unit may not actively leak, the life expectancy of the unit may have been decreased by the damage. In my opinion, the water heater appeared to be in need of replacement at the time of the inspection.



I=Inspected

NI=Not Inspected

NP=Not Present

D= Deficiency

I	NI	NP	D
---	----	----	---

Deficiency: The safety pan was damaged.

Information: The pan was bent over and may be cracked. The pan cannot retain water as designed and intended in its current condition. The safety pan should be replaced.

Deficiency: The drain pipe on the temperature and pressure relief valve was made of inadequate material.

Information: The pipe was listed as CPVC. CPVC pipe deforms or melts at 180 pounds per square inch pressure at 100 degrees Fahrenheit. The valve is manufactured to trip at 150 psi at 210 degrees. If the valve were to trip, it is likely that the drain pipe would fail. The drain pipe required by the manufacturer is either galvanized or thick walled copper. These pipes will withstand the temperature and pressure requirements of the valve. While some local municipal codes will allow the use of CPVC pipe on the valve, the model buildings codes, the manufacturer of the tank and the manufacturer of the valve do not. The drain pipe should be replaced in my opinion.

D. Hydro-Massage Therapy Equipment

Comments:

V. APPLIANCES

A Dishwashers

Comments:

Items noted during the visual inspection that were deemed deficient, are in need of repair, adjustment, restoration, that require comment, continuation of the due diligence process and/or servicing or items noted for information include but are not limited to:

Deficiency: Installation of the dishwasher appeared incomplete and the unit had not been placed into service at the time of the inspection.



Information: The unit should be placed into service and tested for proper and safe operation prior to the termination of any due diligence investigation period.

B. Food Waste Disposers

Comments:

Items noted during the visual inspection that were deemed deficient, are in need of repair, adjustment, restoration, that require comment, continuation of the due diligence process and/or servicing or items noted for information include but are not limited to:

Deficiency: The disposer did not operate properly.

I=Inspected

NI=Not Inspected

NP=Not Present

D= Deficiency

I	NI	NP	D
---	----	----	---

Information: The disposer should be repaired or replaced.



■ □ □ □ **C. Range Hood and Exhaust Systems**

Comments:

Items noted during the visual inspection that were deemed deficient, are in need of repair, adjustment, restoration, that require comment, continuation of the due diligence process and/or servicing or items noted for information include but are not limited to:



Information: There were no visible defects noted in the range hood or vent system at the time of the inspection that appeared to require immediate repair at the time of the inspection, in my opinion.

■ □ □ ■ **D. Ranges, Cooktops, and Ovens**

Comments:

Items noted during the visual inspection that were deemed deficient, are in need of repair, adjustment, restoration, that require comment, continuation of the due diligence process and/or servicing or items noted for information include but are not limited to:

COOKTOP ENERGY SOURCE: Natural Gas

I=Inspected NI=Not Inspected NP=Not Present D= Deficiency

I NI NP D

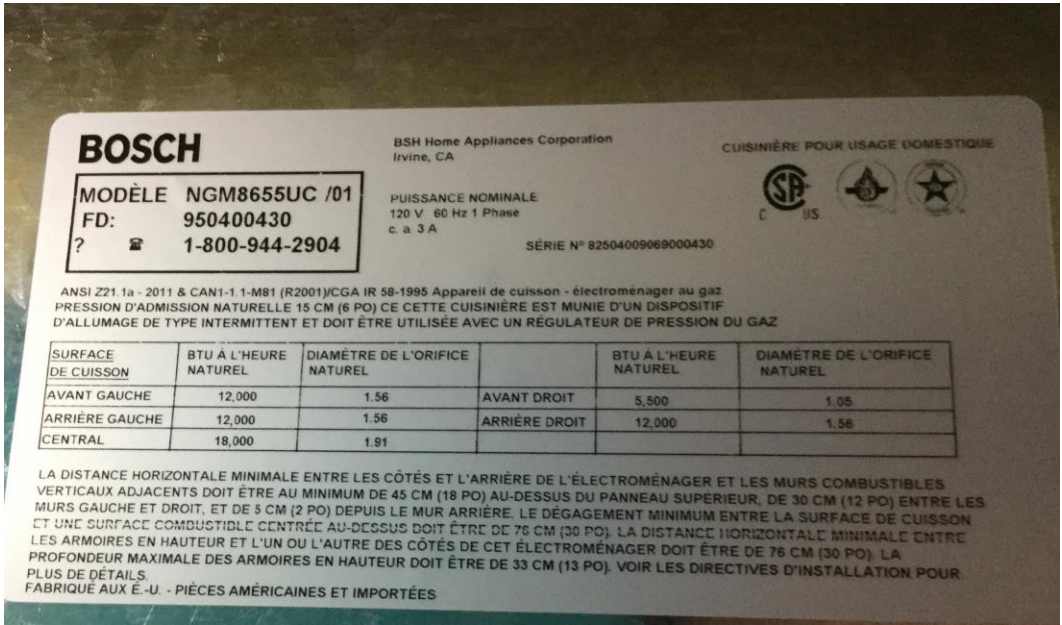

OVEN MAKE: ENERGY SOURCE: Electric

Deficiency: The oven had not been placed into service at the time of the inspection.



Information: The unit should be placed into service and tested for proper and safe operation prior to the termination of any due diligence investigation period.

■ □ □ ■ E. Microwave Ovens

Comments:

Items noted during the visual inspection that were deemed deficient, are in need of repair, adjustment, restoration, that require comment, continuation of the due diligence process and/or servicing or items noted for information include but are not limited to:

Deficiency: The unit had not been placed into service at the time of the inspection.

I=Inspected

NI=Not Inspected

NP=Not Present

D= Deficiency

I	NI	NP	D
---	----	----	---

Information: The unit should be placed into service and tested for proper and safe operation prior to the termination of any due diligence investigation period.

■ □ □ ■ **F. Mechanical Exhaust Vents and Bathroom Heaters**

Comments:

Items noted during the visual inspection that were deemed deficient, are in need of repair, adjustment, restoration, that require comment, continuation of the due diligence process and/or servicing or items noted for information include but are not limited to:

Deficiency: The vent pipe terminations outside the house could not be verified.

Information: The exhaust fan vent pipes are required to terminate through the roof. The primary purpose of a bathroom exhaust vent system is to remove water vapor (humidity) from the interior of the bathroom. The vents can allow excess moisture from the bathroom in the form of humidity into the attic and deterioration of the framing members may result. The vent may also allow sewer gases, which may contain methane, into the attic. The vent pipes should be properly terminated in a listed roof jack.

■ □ □ ■ **G. Garage Door Operators**

Comments:

Items noted during the visual inspection that were deemed deficient, are in need of repair, adjustment, restoration, that require comment, continuation of the due diligence process and/or servicing or items noted for information include but are not limited to:



I=Inspected

NI=Not Inspected

NP=Not Present

D= Deficiency

I	NI	NP	D
---	----	----	---

Deficiency: The manual locking mechanism on the garage door should be removed or disabled.

Information: The manual locking mechanism should be removed or disabled as required by the manufacturer to prevent accidental damage to the door that can occur if the door operator is used when the manual lock is engaged.

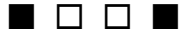

H. Dryer Exhaust Systems

Comments:

Items noted during the visual inspection that were deemed deficient, are in need of repair, adjustment, restoration, that require comment, continuation of the due diligence process and/or servicing or items noted for information include but are not limited to:

Deficiency: The dryer vent pipe, the routing and length of the vent pipe and the termination of the vent pipe were not visible.

Information: The dryer vent pipe must be rigid metal except for an allowable flexible, short section of vent pipe used to connect the dryer to the vent pipe. The overall length of the vent pipe is limited to 25 feet. The total length is reduced by 5 feet for every 90 degree turn and 2.5 feet for every 45 degree turn. The vent pipe must terminate in an approved termination cover equipped with a back draft baffle to prevent air flow and animals from entering the structure. None of these items could be inspected or verified. The dryer vent system should be made accessible and inspected prior to the closing on the house.

References: M1501.3 Length limitation.

The maximum length of a clothes dryer exhaust duct shall not exceed 25 feet (7620 mm) from the dryer location to the wall or roof termination. The maximum length of the duct shall be reduced 2.5 feet (762 mm) for each 45-degree (0.79 rad) bend and 5 feet (1524mm) for each 90-degree (1.6 rad) bend. The maximum length of the exhaust duct does not include the transition duct.

Exceptions:

1. Where a clothes dryer booster fan is installed and listed and labeled for the application, the maximum length of the exhaust duct, including any transition duct, shall be permitted to be in accordance with the booster fan manufacturer's installation instructions. Where a clothes dryer booster fan is installed and not readily accessible from the room in which the dryer is located, a permanent identifying label shall be placed adjacent to where the exhaust duct enters the wall. The label shall bear the words "This dryer exhaust system is equipped with a remotely located booster fan".

2. Where the make and model of the clothes dryer to be installed is known and the manufacturer's installation instructions for such dryer are provided to the building official, the maximum length of the exhaust duct, including any transition duct, shall be permitted to be in accordance with the dryer manufacturer's installation instructions.

The duct length, the number and angle of fittings, and the smoothness of the duct interior all contribute to the total friction loss of the air flow. When the friction loss is excessive, a slowdown of the air velocity occurs, allowing lint and debris to accumulate in the duct and thus creating a fire hazard. The manufacturer's instructions and the code limitations must be adhered concerning duct length, the number of elbows installed, and the type of termination fittings. Exception 1 allows the duct length to exceed 25 feet (7620 mm) if a booster fan listed for this application is installed in the duct to maintain or increase the flow velocity. This exception allows the booster fan manufacturer to specify the duct length. If the booster fan is not located in the same room as the clothes dryer, a permanent label or sign is required to notify residents that a booster fan exists in the duct system.

I=Inspected

NI=Not Inspected

NP=Not Present

D= Deficiency

I	NI	NP	D
----------	-----------	-----------	----------

The maximum exhaust duct length of 25 feet (7620 mm) is the normal installation requirement for domestic clothes dryers. The 25-foot (7620 mm) limit is based on the worst case scenario where the dryer is rated for a maximum duct length of 25 feet (7620 mm). Exception 2 allows longer exhaust duct lengths when the manufacturer's instructions specify the additional length. The make and model of the dryer must be provided to the code official, along with the installation instructions, to permit the code official to inspect the duct installation based on the manufacturer's instructions. A point to consider is the situation that will exist when the original occupant moves out and the new occupant does not install a similar dryer that allows the longer duct length. If the duct is not marked in a conspicuous manner, the new resident will be unaware of the potentially hazardous situation that has been created by the dryer and exhaust mismatch. From the Commentary to the IRC.