

RESERVE A - BLOCK 1
ALTA BROOK APARTMENTS
F.C. No.527264 H.C.M.R.

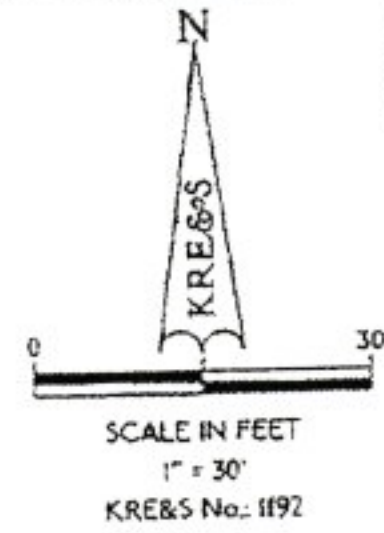

BUTTERCUP ST.
60' R-O-W

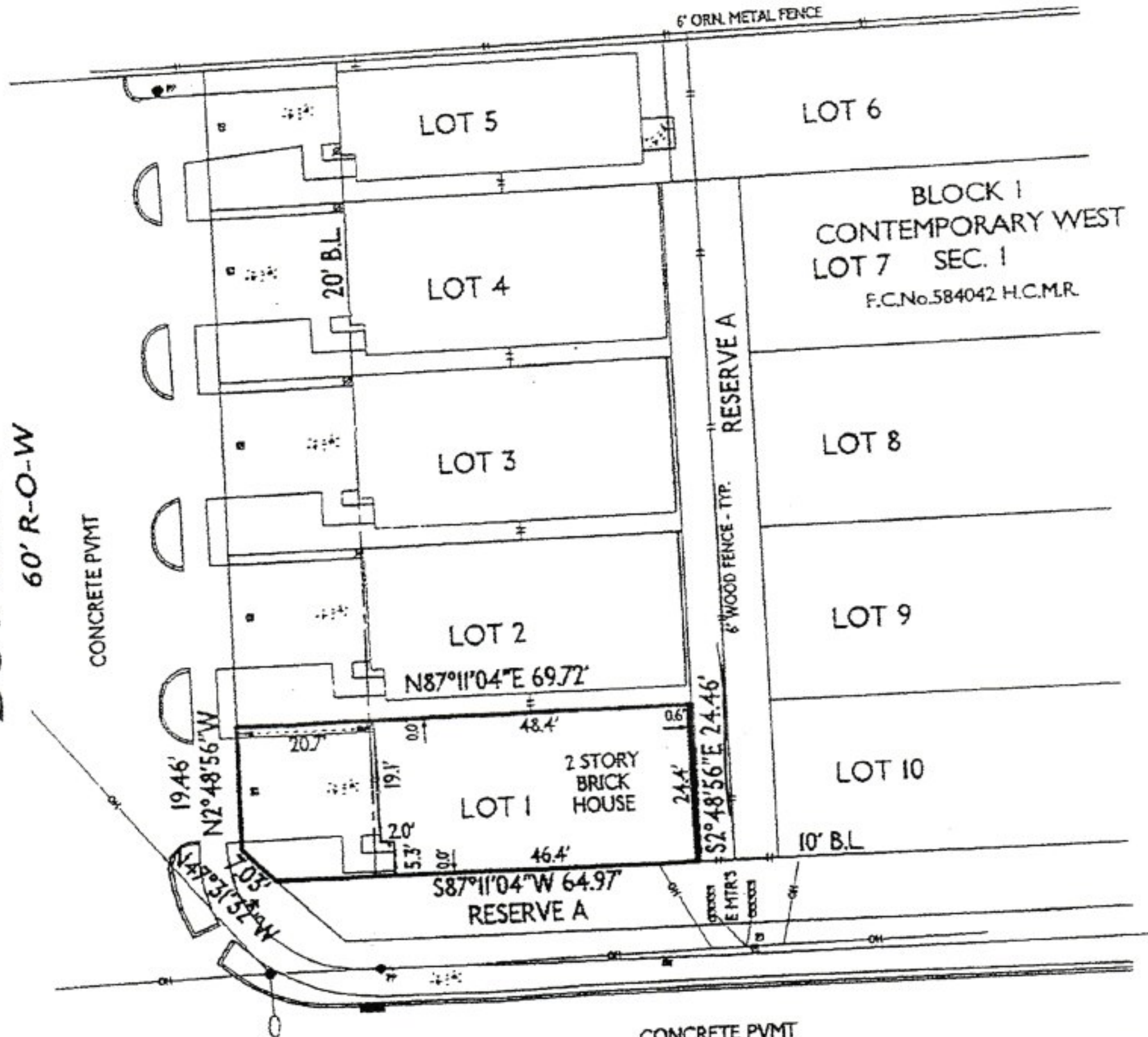

MEADOWCROFT DRIVE
60' R-O-W

- NOTES:
1. THIS SURVEY HAS RELIED ON THE COMMITMENT FOR TITLE POLICY BINDER PREPARED BY STEWART TITLE COMPANY, FILE No.0612762, ISSUED 6/8/06, FOR MATTERS OF RECORD.
 2. ACCORDING TO FIRM No.4820CDRESS K, DATED APRIL 20, 2000, THIS PROPERTY IS LOCATED IN ZONE X, UNSHADED.
 3. NOT ALL FENCES, MECH. EQ. & UTILITIES WERE IN PLACE AT THE TIME OF THIS SURVEY.
 4. THIS LOT IS SUBJECT TO THE PRIVATE UTILITIES AGREEMENT PER HCCP#7654402.
 5. THIS LOT IS SUBJECT TO THE DECLARATION OF COVENANTS, CONDITIONS AND RESTRICTIONS RECORDED UNDER HCCP#2296480.

PURCHASER: TAQI RIZVI
ADDRESS: 3027 BUTTERCUP STREET

I HEREBY CERTIFY TO STEWART TITLE CO. THAT THIS SURVEY SUBSTANTIALLY COMPLIES WITH THE CURRENT T.S.P.S. STANDARDS AND SPECIFICATIONS FOR A CATEGORY IA, CONDITION II SURVEY.

Karen Rose 6/14/06
Shawna
T. Rizvi

KRE&S
KAREN ROSE ENGINEERING & SURVEYING
2330 WELCH AVENUE HOUSTON, TEXAS 77019
email: krose@kre-s.com

TITLE SURVEY OF
LOT 1, BLOCK 1
CONTEMPORARY WEST SEC. 1
FILM CODE No.584042 H.C.M.R.
CITY OF HOUSTON
HARRIS COUNTY, TEXAS