

VICINITY MAP NOT TO SCALE

\* THIS INFORMATION IS BASED ON GRAPHIC PLOTTING ONLY. WE DO NOT ASSUME RESPONSIBILITY PLEASE REFER TO FEMA FLOOD INSURANCE STUDY OF CORRESPONDING COUNTY AND INCORPORATED AREAS FOR EXACT DETERMINATION. FEMA WEBSITE <https://msc.fema.gov/webapp/wcs/stores/servlet/FemaWelcomeView?storeId=10001&catalogId=10001&langId=-1>  
 ALL OF THIS PROPERTY LIES IN ZONE "X" OF THE FLOOD INSURANCE RATE MAP, COMMUNITY 480296 PANEL NO. 48201C-0660 M WHICH BEARS AN EFFECTIVE DATE JUNE 09, 2014 ZONE "X" UNSHADED DENOTES AREAS OUTSIDE THE 500 YEAR FLOOD PLAIN. CURRENTLY EFFECTIVE FEMA MAP NO LOMR RESEARCH HAS BEEN DONE

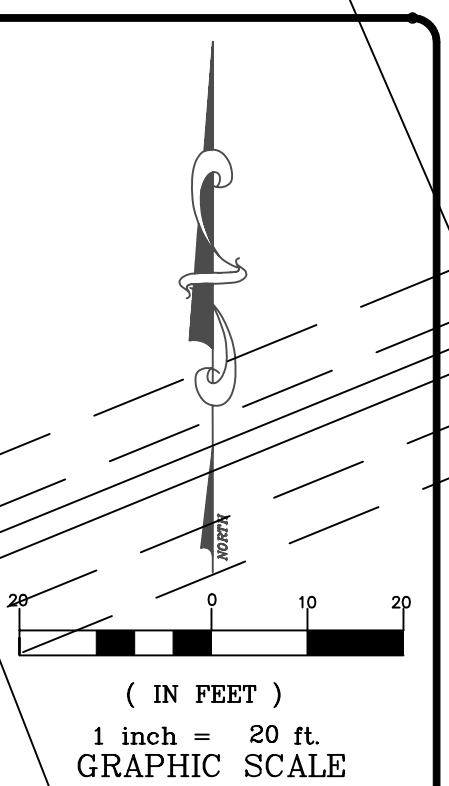

**LEGEND**

N	NORTH
S	SOUTH
E	EAST
W	WEST
BO	BOLLARD
ICV	IRRIGATION CONTROL VALVE
WM	WATER METER
WV	WATER VALVE
FH	FIRE HYDRANT
WRV	WATER RELEASE VALVE
GV	GAS VALVE
GM	GAS METER
GI	GRATE INLET
MI	MANHOLE
GT	GREASE TRAP MANHOLE
CO	CLEAN OUT
MW	METER WELL
TP	TRANSFORMER PEDestal
PO	POST
SBC	SOUTHWESTERN BELL SIGN
TJB	TRAFFIC JUNCTION BOX
EB	ELECTRIC BOX
LP	LIGHT POLE
PP	POWER POLE
MP	METER POLE
SP	SERVICE POLE
TLP	TRAFFIC LIGHT POLE
A/C	AIR CONDITIONING UNIT
GW	GUY WIRE ANCHOR
U	OVERHEAD UTILITY LINE
H	HIGH BANK
POB	POINT OF BEGINNING
FND 5/8 IR	FOUND 5/8 INCH IRON ROD
EASMT	EASEMENT
H.C.C.F.#	HARRIS COUNTY CLERK'S FILE NO.
H.C.D.R.	HARRIS COUNTY DEED RECORDS
H.C.M.R.	HARRIS COUNTY MAP RECORDS
—	CHAIN LINK FENCE
—	WOOD
—	BARBED WIRE FENCE
—	ROUGH IRON FENCE
—	WATER LINE UNDERGROUND
—	SANITARY LINE UNDERGROUND
—	STORM LINE UNDERGROUND
—	TELEPHONE LINES

**CERTIFICATION**  
 I GILBERT PRIDA A REGISTERED PROFESSIONAL LAND SURVEYOR OF THE STATE OF TEXAS DO HEREBY CERTIFY THAT THIS PLAT WAS MADE FROM AN ACTUAL ON THE GROUND SURVEY MADE BY ME OR UNDER MY SUPERVISION AND HAVE SHOWN OR NOTED ALL RECORDED EASEMENTS OR RIGHTS-OF-WAY LISTED IN THE TITLE REPORT, AND SHOWN ALL OBSERVABLE ABOVE THE GROUND EVIDENCE OF EASEMENTS.

GILBERT PRIDA  
 REGISTERED PROFESSIONAL LAND SURVEYOR  
 STATE OF TEXAS NO. 5662

DATE: 11/19/2016



BASIS OF BEARINGS THE RECORDED PLAT OF LINCOLN CITY IN VOL 22 PAGE 40 H.C.M.R.  
 THE PLAT IN BLOCK 6 DOES NOT FORM A MATHEMATICAL CLOSED FIGURE

- GENERAL NOTES:**
1. SUBJECT TO RESTRICTIVE COVENANTS SET OUT IN VOL. 22 PAGE 40 H.C.M.R. AND IN VOL. 1492 PG. 445 H.C.D.R.
  2. SUBJECT TO A 5' UTILITY EASEMENT WITH 5' X 20' A.E. IN VOL. 22 PG. 40 H.C.M.R. AS SHOWN "A".
  3. SUBJECT TO A 25' BUILDING LINE IN VOL. 22 PG. 40 H.C.M.R. AS SHOWN "B".
  4. SURVEY IS BASED ON TITLE REPORT BY FIDELITY NATIONAL TITLE WITH CP NO. 49221603327 WITH AN EFFECTIVE DATE OF 10/03/2016, 9:00AM. ISSUED 10/10/2016.
  5. PROPERTY SUBJECT TO CITY OF HOUSTON ORDINANCE 85-1874 RECORDED IN H.C.C.F.# N-253866, AMENDED IN 1998-262.
  6. PROPERTY SUBJECT TO CITY OF HOUSTON ORDINANCE 69-1312 RECORDED IN H.C.C.F.# M-337573.

**LAND BOUNDARY SURVEY**  
 A LAND TITLE SURVEY CONTAINING 0.2981 ACRES 12,984 SQUARE FEET OF LAND OUT OF LOTS 240 AND 241 BLOCK 6 OF LINCOLN CITY SECTION 5 RECORDED IN VOLUME 22 PAGE 40 H.C.M.R. LOCATED IN THE H AND T.C. R.R. CO. SEC. 10 SURVEY A- HARRIS COUNTY, TEXAS.

DATE: 11/01/2016

PURCHASER: BOYYA PROPERTIES INVESTMENT  
 ADDRESS: 1052/1056 SOUTH LANE, HOUSTON TEXAS 77088

LENDER:

SURVEYOR  
**MOMENTUM**  
 ENGINEERING + SURVEYING  
 12651 BRIAR FOREST, SUITE 350  
 HOUSTON, TEXAS 77077  
 (TEL) 281-741-1998 (FAX) 281-741-2068