

DESERT CALICO LN.
(60' R.O.W.)

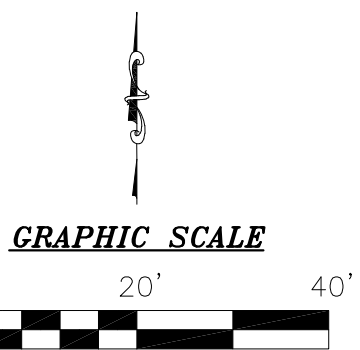

I, DAVID E. KING, JR, a Registered Professional Land Surveyor in the State of Texas, do hereby certify to TEXAS TITLE GIERING INVESTMENTS, LLC and that the above map is true and correct according to an actual field survey, made by me or under my supervision, of the property shown hereon or described by field notes accompanying this drawing. I further certify that all easements and rights-of-way of which I have been advised are shown hereon and that, except as shown, there are no apparent visible encroachments, no apparent visible overlapping of improvements and no apparent discrepancies or conflicts in the boundary lines, as of the date of the field survey.

Lot(s) 11, Block 6, BRADFORD PARK, SEC. 1 recorded in Plat No. 20050034, of the Map/Deed and Plat Records of FORT BEND County, Texas. located in the I. & G. N. RAILROAD COMPANY SURVEY, A-367
Borrower: GIERING INVESTMENTS, LLC
Address: 19310 DESERT CALICO LN., RICHMOND, TX 77407 GF No. 1911234-500

LAND TITLE SURVEY			
JOB NO.:	1909017266	NO.	REVISION
DATE:	09/26/19		
DRAWN BY:	SJ/AV		
APPROVED BY:	DEK		



SUBJECT TO RESTRICTIVE COVENANTS AND/OR EASEMENTS RECORDED IN: PLAT NO 20050034, PLAT RECORDS, FORT BEND COUNTY, TEXAS CLERK'S FILE NOS. 2004003234, 2005047404, 2005054697, 2005112309, 2010007632, 2012003916, 2012003917, 2012003918, 2012003919, 2012012130, 201201231, 2013004434, 2013125745, 2013148054, 2016005384, 21016058284, 2018067473, OFFICIAL PUBLIC RECORDS, FORT BEND COUNTY, TEXAS

PROPERTY PHOTOGRAPH:



FIRM REGISTRATION NO. 10190700
DAVID E. KING, R.P.L.S.
Registered Professional Land Surveyor
Registration No. 6272
COPYRIGHT ALL RIGHTS RESERVED TO OVERLAND CONSORTIUM INC.

Overland Consortium Inc. Surveyors

Tel: 281-940-8869 Fax: 281-207-6476

1528 W. CONTOUR DR., SUITE 204, SAN ANTONIO, TX 78212