

DESIGNER INFORMATION



BUYER NAME	SHOWCASE
QUOTE	Q-39764
ADDRESS	37 NORTH WATERBRIDGE DR
COMMUNITY	WOODLANDS 80
DESIGNER	JEANNINE RILEY
PHONE	281-664-7267
EMAIL	JRILEY@DARLINGHOMES.COM
DATE	12/23/19
NOTES	



Division: Darling Homes Houston - Homebuilding

Community: Woodlands 80s sec 15, 29

Lot Number: Lot 14 (02901402)

Quote Number: Q-39764

Model: PLAN 7247 ELEVATION M (Elevation: M)

Buyer(s):

Co-Buyer:

Address: 37 North Waterbridge Dr, The Woodlands, TX, 77375

Swing: Left

Date Printed: 12/23/2019

Product Code	Name	Qty	List Unit Price	Total Price
(Order #: To Be Approved)				
<i>Category: Cab Acc-Glass Dr</i>				
CCAG0030	CABINET-GLASS DOOR PREP ON STACKED UPPER (DOES NOT INCLUDE GLASS). GLASS SHELVES TO BE PURCHASED SEPERATELY 7 AT KITCHEN COOKTOP WALL	7.00	\$50.00	\$350.00
GLRD0002	CLEAR GLASS FOR STACKED UPPEERS PRICED PER DOOR-DECORATIVE - SELECTION REQUIRED CLEAR GLASS / 7 AT KITCHEN COOKTOP WALL	7.00	\$95.00	\$665.00
<i>Category: Cab Acc-Other</i>				
CCAO0050	CABINET-CLASSIC-ADD UPPER CABINET MOULDING ALONG BOTTOM-LIP	1.00	\$0.00	\$0.00
CCAO0391	CLASSIC-TRASH PULLOUT ^DOUBLE AC128 1 AT KITCHEN ISLAND	1.00	\$465.00	\$465.00
CCAO1102	CABINET-MICROWAVE WALL CABINET UPPER (DOES NOT INCLUDE APPLIANCE) - PIGMENTED TOP COAT	1.00	\$220.00	\$220.00

Category: Cab Trtmnt-Dr Style

CABINET-1ST DOOR
UPG-KITCHEN/BREAKFAST/BUTLERS (DOES NOT

CCTD1301	INCLUDE ISLAND) - PIGMENTED TOP COAT <i>DOOR STYLE: GROVELAND</i>	1.00	\$200.00	\$200.00
CCTD1304	CABINET-1ST DOOR UPGRADE-MASTER BATH - PIGMENTED TOPCOAT <i>DOOR STYLE: GROVELAND</i>	1.00	\$95.00	\$95.00
CCTD1302	CABINET-1ST DOOR UPGRADE-ISLAND ONLY - PIGMENTED TOPCOAT <i>DOOR STYLE: GROVELAND</i>	1.00	\$70.00	\$70.00

Category: Cab Trtmnt-Wood Hood

CCTW1300	CABINET-WOODHOOD-GROUP 1- PIGMENTED TOPCOAT (DOES NOT INCLUDE APPLIANCES) <i>STYLE: WH04</i>	1.00	\$270.00	\$270.00
----------	--	------	----------	----------

Category: Cabs - Species

CCSP6020	CABINET-CLASSIC-PIGMENTED FINISH-BATH 3 <i>DOOR STYLE: LEXINGTON / COLOR: LONDON SKYLINE / FINISH: LOW SHEEN</i>	1.00	\$160.00	\$160.00
CCSP6250	CABINET-CLASSIC-PIGMENTED FINISH-UTILITY UPPERS - INCLUDES CABINET GRADE SHELF PER PLAN <i>DOOR STYLE: LEXINGTON / COLOR: SNOWDRIFT / FINISH: LOW SHEEN</i>	1.00	\$200.00	\$200.00
CCSP6240	CABINET-CLASSIC-PIGMENTED FINISH-UTILITY OTHERS <i>DOOR STYLE: LEXINGTON / COLOR: SNOWDRIFT / FINISH: LOW SHEEN</i>	1.00	\$5,410.00	\$5,410.00
CCSP6170	CABINET-CLASSIC-PIGMENTED FINISH-MASTER BATH <i>DOOR STYLE: SEE UPGRADE / COLOR: SNOWDRIFT / FINISH: LOW SHEEN</i>	1.00	\$280.00	\$280.00
CCSP6130	CABINET-CLASSIC-PIGMENTED FINISH-KITCHEN <i>DOOR STYLE: SEE UPGRADE / COLOR: SNOWDRIFT / FINISH: LOW SHEEN</i>	1.00	\$930.00	\$930.00
CCSP6120	CABINET-CLASSIC-PIGMENTED FINISH-ISLAND <i>DOOR STYLE: SEE UPGRADE / COLOR: LONDON SKYLINE / FINISH: LOW SHEEN</i>	1.00	\$430.00	\$430.00
CCSP6110	CABINET-CLASSIC-PIGMENTED FINISH-HALF BATH <i>DOOR STYLE: LEXINGTON / COLOR: LONDON SKYLINE / FINISH: LOW SHEEN</i>	1.00	\$120.00	\$120.00
CCSP6070	CABINET-CLASSIC-PIGMENTED FINISH-BUTLERS <i>DOOR STYLE: SEE UPGRADE / COLOR: SNOWDRIFT / FINISH: LOW SHEEN</i>	1.00	\$210.00	\$210.00
CCSP6040	CABINET-CLASSIC-PIGMENTED FINISH-BATH 5 <i>DOOR STYLE: LEXINGTON / COLOR: LONDON SKYLINE / FINISH: LOW SHEEN</i>	1.00	\$240.00	\$240.00
CCSP6030	CABINET-CLASSIC-PIGMENTED FINISH-BATH 4 <i>DOOR STYLE: LEXINGTON / COLOR: LONDON SKYLINE / FINISH: LOW SHEEN</i>	1.00	\$160.00	\$160.00

CCSP6010	CABINET-CLASSIC-PIGMENTED FINISH-BATH 2 DOOR STYLE: LEXINGTON / COLOR: LONDON SKYLINE / FINISH: LOW SHEEN	1.00	\$160.00	\$160.00
----------	---	------	----------	----------

CCSP1230	CABINET-CLASSIC-MAPLE-POWDER (FURNITURE) AVAILABLE IN TRADITIONAL/TRANSITIONAL/CONTEMPORARY. COMES WITH STD SINK PS7504 CABINET STYLE: CONTEMPORARY / COLOR: ESPRESSO / FINISH: MATTE	1.00	\$0.00	\$0.00
----------	--	------	--------	--------

Category: Cabs-Species-Add LF

CCSL0085	CABINET-CLASSIC-ADD LF-STACKED UPPERS-PIGMENTED TOPCOAT 17 LF AT KITCHEN	17.00	\$280.00	\$4,760.00
----------	--	-------	----------	------------

Category: Ceiling Fans

ELCF0007	LEVEL 1- 52" STARKK 300173NI ILO OF LEVEL 1 1 AT FAMILY, 1 AT STUDY, 1 AT GAME ROOM, 1 AT MASTER BEDROOM, 1 AT BEDROOM 2, 1 AT BEDROOM 3, 1 AT BEDROOM 4, 1 AT BEDROOM 5 Material - Glass - BLADE COLOR: SILVER	8.00	\$0.00	\$0.00
		8		

Category: Custom

CUST9643	Custom Wood Stairs FULL WHITE OAK TREADS W/PAINTED RISERS / TREAD COLOR: MW411 BIRCHBARK / RISER COLOR: TO MATCH TRIM / FRONT STAIRS ONLY	1.00	\$10,880.00	\$10,880.00
CUST9680	Custom Carpet SEE BUYER SELECTIONS REPORT & REDLINE FOR DETAILS	1.00	\$4,301.00	\$4,301.00
CUST9640	Custom Wood-Pre finished Engineered Glue Down SEE BUYER SELECTIONS REPORT & REDLINE FOR DETAILS	1.00	\$22,346.00	\$22,346.00
CUST9620	Custom Wall Tile SEE BUYER SELECTIONS REPORT FOR DETAILS	1.00	\$2,482.00	\$2,482.00
CUST9615	Custom Tile B/S SEE BUYER SELECTIONS REPORT FOR DETAILS	1.00	\$872.00	\$872.00
CUST9610	Custom Tile Flooring SEE BUYER SELECTIONS REPORT & REDLINE FOR DETAILS	1.00	\$3,195.00	\$3,195.00

Category: Custom Interior Specialties

CUST1012	Custom Interior Specialties BATH 5 FRAMED MIRROR - MERCEDES	1.00	\$0.00	\$0.00
CUST1022	Custom Stairparts LEVEL 1 METAL BALUSTERS / STYLE: P-10B / FINISH: SATIN BLACK	1.00	\$0.00	\$0.00
CUST1021	Custom Stairparts WHITE OAK HANDRAIL / COLOR: MW411 BIRCHBARK	1.00	\$0.00	\$0.00

CUST1011	Custom Interior Specialties <i>FRAMED MIRRORS ALL STANDARD BATHS - MERCEDES MASTER BATH (2) TO BE CENTERED ABOVE VANITY SINK(S)</i>	1.00	\$0.00	\$0.00
----------	--	------	--------	--------

Category: Custom Paint

CUST0994	Custom Paint - Add location and color selection in comments. <i>PAINT-BASE- WHOLE HOUSE INTERIOR DOORS AND TRIM / COLOR: SW 7004 SNOWBOUND</i>	1.00	\$0.00	\$0.00
----------	---	------	--------	--------

Category: Custom Plumbing

CUST1533	Custom Plumbing <i>FREESTANDING TUB - THE HUDSON BT-1032 (RENWIL) - 69L X 33W X 27H</i>	1.00	\$0.00	\$0.00
----------	--	------	--------	--------

Category: ENGINEERED COUNTERTOP

CTPP1100	COUNTERTOP-MOUNTAIN TOP ENG STONE-LEVEL 1- BATH 3 <i>COLOR: POLAR WHITE / EDGE: SQUARE</i>	1.00	\$0.00	\$0.00
CTPP1090	COUNTERTOP-MOUNTAIN TOP ENG STONE-LEVEL 1- BATH 2 <i>COLOR: POLAR WHITE / EDGE: SQUARE</i>	1.00	\$0.00	\$0.00
CTPP1110	COUNTERTOP-MOUNTAIN TOP ENG STONE-LEVEL 1- BATH 4 <i>COLOR: POLAR WHITE / EDGE: SQUARE</i>	1.00	\$0.00	\$0.00
CTPP1120	COUNTERTOP-MOUNTAIN TOP ENG STONE-LEVEL 1- BATH 5 <i>COLOR: POLAR WHITE / EDGE: SQUARE</i>	1.00	\$0.00	\$0.00
CTPP1140	COUNTERTOP-MOUNTAIN TOP ENG STONE-LEVEL 1- HALF BATH <i>COLOR: POLAR WHITE / EDGE: SQUARE</i>	1.00	\$0.00	\$0.00
CTPP1170	COUNTERTOP-MOUNTAIN TOP ENG STONE-LEVEL 1- UTILITY <i>COLOR: POLAR WHITE / EDGE: SQUARE</i>	1.00	\$1,060.00	\$1,060.00

Category: Elec - LED

ELPL0125	ADD 1 LED 3000K WHITE PUCK LIGHT ON EXISTING SWITCH. GLASS SHELVES TO BE PURCHASED SEPERATELY <i>6 AT KITCHEN STACKED UPPERS</i>	6.00	\$165.00	\$990.00
ELPL0120	ADD 1 LED 3000K WHITE PUCK LIGHT WITH SWITCH AND DRIVER. GLASS SHELVES TO BE PURCHASED SEPERATELY <i>1 AT KITCHEN STACKED UPPERS</i>	1.00	\$215.00	\$215.00

Category: Elec - Switch Plate Cove

ELSP0000	NOTE: SWITCH PLATE COVER COLOR WHITE THROUGHOUT EXCEPT MEDIA ROOM. BLACK AT MEDIA ROOM ONLY.	1.00	\$0.00	\$0.00
----------	--	------	--------	--------

Category: Elec - Swtch & Outlet

ELEC0180	ADD LIGHTING PREWIRE - INTERIOR ON EXISTING SWITCH UP TO 50 LB FIXTURE 2 AT KITCHEN ISLAND FOR PENDANTS	2.00	\$85.00	\$170.00
ELEC0200	ADD LIGHTING PREWIRE - INTERIOR (WITH SWITCH) UP TO 50 LB FIXTURE 1 AT KITCHEN ISLAND FOR PENDANTS	1.00	\$165.00	\$165.00

Category: GRANITE

CTPG6060	COUNTERTOP-GRANITE 3CM-LEVEL 6-MASTER BATH - 90" or more may require seam. COLOR: BLUE BONNET / EDGE: SQUARE	1.00	\$1,220.00	\$1,220.00
CTPG5080	COUNTERTOP-GRANITE 3CM-LEVEL 5-POWDER - 90" or more may require seam. COLOR: BLUE DUNES / EDGE: SQUARE	1.00	\$230.00	\$230.00
CTPG5020	COUNTERTOP-GRANITE 3CM-LEVEL 5-BUTLERS - 90" or more may require seam. COLOR: BLUE DUNES / EDGE: SQUARE	1.00	\$500.00	\$500.00
CTPG5010	COUNTERTOP-GRANITE 3CM-LEVEL 5-ISLAND - 90" or more may require seam. COLOR: BLUE DUNES / EDGE: SQUARE	1.00	\$960.00	\$960.00
CTPG5000	COUNTERTOP-GRANITE 3CM-LEVEL 5-KITCHEN - 90" or more may require seam. COLOR: BLUE DUNES / EDGE: SQUARE	1.00	\$960.00	\$960.00

Category: Hardware

HTBR0020	HARDWARE--TOWEL BAR-BRUSHED NICKLE-BRANTFORD 1 AT MASTER BATH, 1 AT BATH 2, 1 AT BATH 3, 1 AT BATH 4, 1 AT BATH 5	5.00	\$0.00	\$0.00
HPPR0020	HARDWARE--PAPER HOLDER-BRUSHED NICKLE-BRANTFORD 1 AT MASTER BATH, 1 AT POWDER, 1 AT BATH 2, 1 AT BATH 3, 1 AT BATH 4, 1 AT BATH 5, 1 AT HALF BATH	7.00	\$0.00	\$0.00
HTRG0020	HARDWARE--TOWEL RING-BRUSHED NICKLE-BRANTFORD 2 AT MASTER BATH, 1 AT POWDER, 1 AT BATH 2, 1 AT BATH 3, 1 AT BATH 4, 1 AT BATH 5, 1 AT HALF BATH	8.00	\$0.00	\$0.00

Category: INTERIOR DOOR STYLE

INTD0010	INTERIOR DOOR STYLE STYLE - CAMBRIDGE	1.00	\$0.00	\$0.00
----------	--	------	--------	--------

Category: Interior Door Trim / Hardware

DRHW2316PKG	INTERIOR LEVERS-ACCENT	1.00	\$700.00	\$700.00
	<i>Finish - Satin Nickel (619)</i>	<i>1</i>		
DRHW2164EXT	HANDLESET-ADDISON	1.00	\$60.00	\$60.00
	<i>Finish - Satin Nickel (619)</i>	<i>1</i>		
DRHW1177EXT	DEADBOLT-JD60	1.00	\$0.00	\$0.00
	<i>Finish - Satin Nickel (619)</i>	<i>1</i>		

Category: Kitchen Sinks

KSSG0060	KITCHEN SINK-SILGRANITE-BLANCO SINGLE BOWL-SG8505	1.00	\$480.00	\$480.00
	<i>COLOR - METALLIC GRAY</i>	<i>1</i>		

Category: Light Fixture Packages

LTFX1081	LIGHT FIX PKG - JOELSON BRUSHED NICKEL	1.00	\$0.00	\$0.00
----------	--	------	--------	--------

Category: Pendant Light Fixtures

LTPE0044	EVERLY PENDANT 42046NICS ON EXISTING CIRCUIT SWITCH. FIXTURE ONLY. INCLUDES BULBS <i>3 AT KITCHEN ISLAND</i>	3.00	\$190.00	\$570.00
----------	---	------	----------	----------

Category: Plumbing Accessories

SHWR0000	NOTES ONLY: BATH SHOWER DOOR FINISH <i>BRUSHED NICKEL AT MASTER BATH & BATH 2</i>	2.00	\$0.00	\$0.00
----------	--	------	--------	--------

Category: Plumbing Fixtures

TUBR0211	ROMAN TUB-BRANTFORD 10"-BRUSHED NICKEL-T933BN + 4796 <i>1 AT MASTER BATH</i>	1.00	\$0.00	\$0.00
TBSH0211	TUB/SHOWER-BRANTFORD-BRUSHED NICKEL-T2153BN + 2510 <i>1 AT BATH 3, 1 AT BATH 4, 1 AT BATH 5</i>	3.00	\$0.00	\$0.00
SHWF0211	SHOWER-BRANTFORD-BRUSHED NICKEL-T2152BN + 2510 <i>1 AT MASTER BATH, 1 AT BATH 2</i>	2.00	\$0.00	\$0.00
LAVW0211	LAVATORY-BRANTFORD-WIDESPREAD 8"-BRUSHED NICKEL-T6620BN + 9000 <i>2 AT MASTER BATH, 1 AT POWDER</i>	3.00	\$0.00	\$0.00
	LAVATORY-BRANTFORD-CENTERSET 4"-BRUSHED NICKEL-6610BN			

LAVC0211	1 AT BATH 2, 1 AT BATH 3, 1 AT BATH 4, 1 AT BATH 5, 1 AT HALF BATH	5.00	\$0.00	\$0.00
UTFX0911	UTILITY FIXTURE-INTEGRA-CLASSIC STAINLESS-67315SRS	1.00	\$320.00	\$320.00
KTFX0123	KITCHEN FIXTURE-ALIGN-5923SRS SPOT RESIST SS	1.00	\$350.00	\$350.00

Category: Utility Sinks

USSS0020	UTILITY SINK-STAINLESS STEEL-SS2513-ELMONT-22-3/4 X 17-1/2	1.00	\$550.00	\$550.00
----------	--	------	----------	----------

Category: Vanity Sinks

VSES0010	VANITY SINK - MOUNTAIN TOP ENGINEERED STONE -OVAL WHITE CHINA BOWL - PS7504 1 AT BATH 2, 1 AT BATH 3, 1 AT BATH 4, 1 AT BATH 5, 1 AT HALF BATH COLOR - WHITE STYLE - OVAL	5.00 5	\$0.00	\$0.00
VSPC0070	MASTER BATH-PORCELAIN-TERRA-PS7505-WHITE COLOR - WHITE STYLE - RECTANGLE	2.00 2	\$200.00	\$400.00
VSPC0071	POWDER-PORCELAIN-TERRA-PS7505-WHITE COLOR - WHITE STYLE - RECTANGLE	1.00 1	\$500.00	\$500.00

Category: WHOLE HOUSE / ACCENT

PNTH0010	PAIN-T-BASE- WHOLE HOUSE INTERIOR WALLS, CEILINGS, DOORS AND TRIM WALLS AND CEILINGS ONLY. SEE SEPARATE SELECTION FOR DOORS AND TRIM. COLOR - SW 7014 Eider White	1.00 1	\$0.00	\$0.00
PNTM0000	PAIN-T INTERIOR - MEDIA ROOM - BASE COLORS *Latex Flat* COLOR - SW 7019 Gauntlet Gray	1.00 1	\$0.00	\$0.00

(Order #: 1 - 12/10/2019)

Category: Cab Acc-Other

CCAO0350	CABINET-CLASSIC-REFRIGERATOR SURROUND FOR BUILT-IN REFRIGERATOR (DOES NOT INCLUDE APPLIANCE)	1.00	\$0.00	\$0.00
CCAO0204	CLASSIC-DRAWER GUIDE--FULL EXTENSION-(WHOLE HOUSE)	1.00	\$0.00	\$0.00

CCAO1300	MOULDING TREATMENTS - CM4 CROWN	1.00	\$0.00	\$0.00
----------	---------------------------------	------	--------	--------

Category: Color Palette

CLM10000	COMMUNITY COLOR PALETTE - MODERN M1 Light-Stucco - Snowbound - SW7004 Medium-Stucco Accents - Passive - SW7064 Dark-Trim, Garage Doors, - Tin Lizzie - SW9163 Wood Tone - Prestained Accent - Woodtone - Bark Accent Color / Front Door -Cyberspace - SW7076 Roof - Moire Black Brick - Triangle-Georgetown- Mortar - Gra	1.00	\$0.00	\$0.00
----------	---	------	--------	--------

Category: Cooktop / Rangetop

CTOP0025	CGU366P2MS1 - CAFE 36" GAS RANGETOP. MAY REQUIRE CABINET REDRAW	1.00	\$0.00	\$0.00
----------	--	------	--------	--------

Category: Custom Building Envelope

CUST1800	ZZ - LOT SPECIFIC MATERIAL ITEMIZATION	1.00	\$0.00	\$0.00
----------	--	------	--------	--------

Category: Dishwashers

DISH0010	CDT845P2NS1- CAFE STAINLESS INT. BUILT-IN DISHWASHER W/ HIDDEN CONTROLS	1.00	\$0.00	\$0.00
----------	--	------	--------	--------

Category: Elec - Swtch &Outlet

ELEF0010	ADD 4 EXTERIOR UPLIGHTS WITH SINGLE SWITCH. LOW PROFILE SGL 15231AZT. TEXTURED ARCHITECTURAL BRONZE. INCLUDES BULBS	1.00	\$0.00	\$0.00
----------	---	------	--------	--------

ELEC0110	ADD FLOOR PLUG - PRE-FOUNDATION ONLY - INCLUDES BRASS TRIM <i>Family Room_ location TBD at precon</i>	1.00	\$460.00	\$460.00
----------	---	------	----------	----------

Category: Fireplace Box

FPIM0002	FIREPLACE-INDOOR-42" DV INTERIOR WALL - DESIGN 2. FIREPLACE MODEL #COSMO SLR-D HEAT AND GLO 42" LINEAR DIRECT VENT CFT-42-BK w/CLEAN FACE TRIM IN BLACK, AND REMOTE CONTROL. INCLUDES SMART-WALL TV KIT AND PAINT GRADE MATERIAL	1.00	\$3,950.00	\$3,950.00
----------	---	------	------------	------------

Category: Front Doors

FRDW4236	MAHOGANY CONTEMPORARY 42" WIDE <i>Newport Single mahogany to be installed. Option is not available in pull down menu but is an option in door book. 42" wide with Water glass. Color: Winter White</i>	1.00	\$1,140.00	\$1,140.00
----------	---	------	------------	------------

MATERIAL - FINISH - MAHOGANY - WINTER WHITE

1

GLASS - DESIGN STYLE - WATER - BEVERLY

Category: Indoor Options

SHWR0002	OPT. SHOWER - BATH 2 - MUDSET - INCLUDES FRAMED SHOWER DOOR AND SHAMPOO NICHE	1.00	\$2,620.00	\$2,620.00
BAYW0001	BAY WINDOW	1.00	\$3,150.00	\$3,150.00
BDRM0055	BEDROOM #5 WITH BATH #5	1.00	\$33,390.00	\$33,390.00
MEDI0002	MEDIA ROOM DOWN - NOT AVAILABLE WITH OPT. MASTER SUITE #2	1.00	\$2,200.00	\$2,200.00
UTLY0001	PRE-PLUM HOT/COLD DRAIN FOR FUTURE UTILITY ROOM SINK - Does not include sink and cabinet.	1.00	\$1,075.00	\$1,075.00
INTM1000	INTERIOR MODERN ARCHITECTURAL DETAILING - Convert Interior framed arches and/or eyebrow openings to square and drywall corners squared. Change does not include windows or doors. Review details at Pre-Construction meeting with construction manager. No architectural redraw required. If buyer request custom re-draw this option must be selected to be included in custom re-draw	1.00	\$0.00	\$0.00

Category: Microwave

MICR0010	CEB515P2NSS/JX9152SJSS - CAFE 1.5 CF CT CONV/M.WAVE - 27" TRIM KIT	1.00	\$0.00	\$0.00
----------	---	------	--------	--------

Category: Outdoor Kitchen

OKPL0001	PRE-PLUMB FOR OUTDOOR KITCHEN: PRICE INCLUDES GAS LINE, HOT AND COLD WATER, DRAIN FOR SINK. MUST BE LOCATED ON OUTSIDE OF BACK WALL OF HOUSE OR IN A COURTYARD. DOES NOT INCLUDE ANY ELECTRIC WHICH MUST BE SPECIFIED AND SELECTED SEPERATELY.	1.00	\$1,650.00	\$1,650.00
----------	---	------	------------	------------

Category: Outdoor Options

CVRD0001	OPTIONAL COVERED PATIO #1	1.00	\$5,225.00	\$5,225.00
	STYLE - COLOR - TBD	1		
DOOR1521	OPT 15' 3-PANEL VINYL WHITE SLIDER DR AT FAMILY ROOM - Unit comes standard with track for future screen and thermal enhanced vinyl frame. Operable screen extra. Requires 8 1/2" jamb minimum. Must specify handle color (White Only)	1.00	\$11,200.00	\$11,200.00
	STYLE - COLOR - TBD	1		

Category: Oven

CTD0DP2NS1 - CAFE 30" BUILT-IN DOUBLE

OVEN0030	CONVECTION WALL OVEN MAY REQUIRE CABINET REDRAW	1.00	\$0.00	\$0.00
----------	---	------	--------	--------

Category: Plumbing Accessories

WTSF0000	DUPURE - SINGLE STAGE FILTER W/STD SPIGOT - TO MATCH KITCHEN FAUCET FIXTURE COLOR.	1.00	\$0.00	\$0.00
GRBG0001	GARBAGE DISPOSAL - COUNTER BUTTON - STAINLESS STEEL OR BRONZE	1.00	\$275.00	\$275.00

Category: Stair Parts

STLM0000	STAIR PARTS - LUXE MODERN	1.00	\$0.00	\$0.00
----------	---------------------------	------	--------	--------

Category: UPDATED PAVERS

PAVD1001	PAVERS - BELGARD - DRIVEWAY BORDER, TO BE SELECTED FROM APPROVED PUBLISHED BELGARD SELECTIONS. DESIGN PATTERN - RANDOM BOND ONLY. <i>Holland Stone: Charcoal</i>	1.00	\$0.00	\$0.00
PAVL1001	PAVERS - BELGARD - LEADWALK BORDER, TO BE SELECTED FROM APPROVED PUBLISHED BELGARD SELECTIONS. DESIGN PATTERN - RANDOM BOND ONLY. <i>Holland Stone: Charcoal</i>	1.00	\$0.00	\$0.00
PAVR1003	PAVERS - BELGARD - MAIN ENTRY PORCH, TO INCL LOGGIA PER PLAN. MUST BE SELECTED FROM APPROVED PUBLISHED BELGARD SELECTIONS. DESIGN PATTERN - STRAIGHT LAY ONLY <i>Holland Stone: Charcoal</i>	1.00	\$0.00	\$0.00

Category: Vent Hood

VENT0240	ZVC36LSS - MONOGRAM 36" CUSTOM HOOD INSERT This product must include the installation of a fresh air intake per applicable codes. MAY REQUIRE CABINET REDRAW	1.00	\$0.00	\$0.00
----------	---	------	--------	--------

Sub Total	\$136,206.00
Lot Premium	\$15,400.00
Base Price	\$741,990.00
Option Total	\$136,206.00
Incentive Given	\$0.00
Total Purchase Price	\$893,596.00

CANCELLED OPTIONS

Product Code	Name	Qty	List Unit Price	Total Price
<i>Category: Cab Acc-Other</i>				
CCAO1101	CABINET-MICROWAVE WALL CABINET UPPER (DOES NOT INCLUDE APPLIANCE) - MAPLE	1.00	\$0.00	\$0.00
<hr/>				
<i>Category: Cab Trtmnt-Dr Style</i>				
CCTD1201	CABINET-1ST DOOR UPG-KITCHEN/BREAKFAST/BUTLERS (DOES NOT INCLUDE ISLAND) - MAPLE	1.00	\$0.00	\$0.00
CCTD1202	CABINET-1ST DOOR UPGRADE-ISLAND ONLY - MAPLE	1.00	\$0.00	\$0.00
CCTD1204	CABINET-1ST DOOR UPGRADE-MASTER BATH - MAPLE	1.00	\$0.00	\$0.00
CCTD1206	CABINET-1ST DOOR UPGRADE-POWDER - MAPLE	1.00	\$0.00	\$0.00
<hr/>				
<i>Category: Cab Trtmnt-Wood Hood</i>				
CCTW1200	CABINET-WOODHOOD-GROUP 1- MAPLE (DOES NOT INCLUDE APPLIANCES)	1.00	\$0.00	\$0.00
<hr/>				
<i>Category: Cabs - Species</i>				
CCSP1070	CABINET-CLASSIC-MAPLE-BUTLERS	1.00	\$0.00	\$0.00
CCSP1120	CABINET-CLASSIC-MAPLE-ISLAND	1.00	\$0.00	\$0.00
CCSP1130	CABINET-CLASSIC-MAPLE-KITCHEN	1.00	\$0.00	\$0.00
CCSP1170	CABINET-CLASSIC-MAPLE-MASTER BATH	1.00	\$0.00	\$0.00
CCSP1230	CABINET-CLASSIC-MAPLE-POWDER (FURNITURE) AVAILABLE IN TRADITIONAL/TRANSITIONAL/CONTEMPORARY. COMES WITH STD SINK PS7504	1.00	\$0.00	\$0.00
CCSP3010	CABINET-CLASSIC-POPLAR-BATH 2	1.00	\$0.00	\$0.00
CCSP3020	CABINET-CLASSIC-POPLAR-BATH 3	1.00	\$0.00	\$0.00
CCSP3030	CABINET-CLASSIC-POPLAR-BATH 4	1.00	\$0.00	\$0.00
CCSP3080	CABINET-CLASSIC-POPLAR-HALF BATH	1.00	\$0.00	\$0.00
CCSP3180	CABINET-CLASSIC-POPLAR-UTILITY UPPERS - INCLUDES CABINET GRADE SHELF PER PLAN	1.00	\$0.00	\$0.00

Category: Ceiling Fans

ELCF0001	LEVEL 1- 52" SUTTER PLACE SELECT 339211AP - PER COMMUNITY SPECS	1.00	\$0.00	\$0.00
	Material - Glass - TBD	1		

Category: ENGINEERED COUNTERTOP

CTPP1090	COUNTERTOP-MOUNTAIN TOP ENG STONE-LEVEL 1- BATH 2	1.00	\$0.00	\$0.00
CTPP1100	COUNTERTOP-MOUNTAIN TOP ENG STONE-LEVEL 1- BATH 3	1.00	\$0.00	\$0.00
CTPP1110	COUNTERTOP-MOUNTAIN TOP ENG STONE-LEVEL 1- BATH 4	1.00	\$0.00	\$0.00
CTPP1120	COUNTERTOP-MOUNTAIN TOP ENG STONE-LEVEL 1- BATH 5	1.00	\$0.00	\$0.00
CTPP1140	COUNTERTOP-MOUNTAIN TOP ENG STONE-LEVEL 1- HALF BATH	1.00	\$0.00	\$0.00

Category: GRANITE

CTPG1060	COUNTERTOP-GRANITE 3CM-LEVEL 1-MASTER BATH - 90" or more may require seam.	1.00	\$0.00	\$0.00
CTPG1080	COUNTERTOP-GRANITE 3CM-LEVEL 1-POWDER - 90" or more may require seam.	1.00	\$0.00	\$0.00
CTPG2000	COUNTERTOP-GRANITE 3CM-LEVEL 2-KITCHEN - 90" or more may require seam.	1.00	\$0.00	\$0.00
CTPG2010	COUNTERTOP-GRANITE 3CM-LEVEL 2-ISLAND - 90" or more may require seam.	1.00	\$0.00	\$0.00
CTPG2020	COUNTERTOP-GRANITE 3CM-LEVEL 2-BUTLERS - 90" or more may require seam.	1.00	\$0.00	\$0.00

Category: Hardware

HPPR0020	HARDWARE--PAPER HOLDER-BRUSHED NICKLE-BRANTFORD	1.00	\$0.00	\$0.00
HTBR0020	HARDWARE--TOWEL BAR-BRUSHED NICKLE-BRANTFORD	1.00	\$0.00	\$0.00
HTRG0020	HARDWARE--TOWEL RING-BRUSHED NICKLE-BRANTFORD	1.00	\$0.00	\$0.00

Category: INTERIOR DOOR STYLE

INTD0010	INTERIOR DOOR STYLE	1.00	\$0.00	\$0.00
	STYLE - Per STD Specs - to be finalized at Design Center	1		

Category: Interior Door Trim / Hardware

DRHW1176EXT	HANDLESET-PLYMOUTH - (REPLACES BARCELONA)	1.00	\$0.00	\$0.00
	Finish - Per STD Specs - to be finalized at Design Center	1		
DRHW1142PKG	INTERIOR LEVERS-SEVILLE	1.00	\$0.00	\$0.00
	Finish - Per STD Specs - to be finalized at Design Center	1		
DRHW1177EXT	DEADBOLT-JD60	1.00	\$0.00	\$0.00
	Finish - Per STD Specs - to be finalized at Design Center	1		

Category: Kitchen Sinks

KSSS0010	KITCHEN SINK--STAINLESS STEEL-BRENNER-SS2504-UNDERMOUNT DOUBLE BOWL 60/40-18 GAUGE- 32 X 20- 3/4	1.00	\$0.00	\$0.00
	COLOR - TBD	1		

Category: Light Fixture Packages

LTFX1130	LIGHT FIX PKG - BRAELYN OLDE BRONZE	1.00	\$0.00	\$0.00
----------	-------------------------------------	------	--------	--------

Category: Mirrors

FRMR0001	FRAMED MIRRORS ALL STANDARD BATHS - EMERY MASTER BATH (2) TO BE CENTERED ABOVE VANITY SINK(S)	1.00	\$0.00	\$0.00
----------	---	------	--------	--------

Category: Plumbing Accessories

SHWR0000	NOTES ONLY: BATH SHOWER DOOR FINISH	1.00	\$0.00	\$0.00
----------	-------------------------------------	------	--------	--------

Category: Plumbing Fixtures

KTFX0131	KITCHEN FIXTURE-ARBOR-PULL DOWN-SPOT RESIST STAINLESS-7594SRS	1.00	\$0.00	\$0.00
TUBR0211	ROMAN TUB-BRANTFORD 10"-BRUSHED NICKEL-T933BN + 4796	1.00	\$0.00	\$0.00
	LAVATORY-BRANTFORD-CENTERSET 4"-BRUSHED			

LAVC0211	NICKEL-6610BN	1.00	\$0.00	\$0.00
LAVW0211	LAVATORY-BRANTFORD-WIDESPREAD 8"-BRUSHED NICKEL-T6620BN + 9000	1.00	\$0.00	\$0.00
SHWF0211	SHOWER-BRANTFORD-BRUSHED NICKEL-T2152BN + 2510	1.00	\$0.00	\$0.00

Category: Vanity Sinks

VSPC0010	MASTER BATH-PORCELAIN-WHITE-PS7504	1.00	\$0.00	\$0.00
	<i>COLOR - TBD</i>	<i>1</i>		
	<i>STYLE - TBD</i>			
VSPC0011	POWDER-PORCELAIN-WHITE-PS7504	1.00	\$0.00	\$0.00
	<i>COLOR - TBD</i>	<i>1</i>		
	<i>STYLE - TBD</i>			
VSES0010	VANITY SINK - MOUNTAIN TOP ENGINEERED STONE -OVAL WHITE CHINA BOWL - PS7504	1.00	\$0.00	\$0.00
	<i>COLOR - TBD</i>	<i>1</i>		
	<i>STYLE - TBD</i>			

Category: WHOLE HOUSE / ACCENT

PNTH0010	PAINT-BASE- WHOLE HOUSE INTERIOR WALLS, CEILINGS, DOORS AND TRIM	1.00	\$0.00	\$0.00
	<i>COLOR - SW 6105 Divine White</i>	<i>1</i>		

This system-generated *Proposal* is provided to a prospective buyer and/or its Broker/Agent outside of and not made a part of the Purchase Agreement: (1) all information as of the date indicated remains subject to change at any time without notice or obligation; and (2) is for illustrative and informational purposes only for preliminary discussions for prospective buyer's convenience. No guarantee or representation is made or implied as to availability, manufacturer, style, size, color, number, pricing and other factors installed in the completed home and/or subject to applicable incentives (if any) affecting pricing, all of which Seller reserves the right to modify. Refer to the final executed: Purchase Agreement and its attached Addenda (inclusive of any post-purchase amendments thereto) and the specific Community's Standard Features List for complete details. Equal Housing Builder.



Buyer Selections Report

Darling Homes Houston - 12/23/2019 8:04:14 AM

BUYER: Showcase Home 37 North Waterbridge Dr	DESIGNER: Jeannine Riley	SALES COUNSELOR: Other/Unknown	CATALOG DATE: 12/11/2019 3:50:50 PM	JOB NUMBER: Q-39764
---	------------------------------------	--	---	-------------------------------

ADDRESS: 37 North Waterbridge Dr	LOT / BLOCK:	COMMUNITY: Woodlands 80	SERIES: Luxe	PLAN: 7247	ELEV: M
---	---------------------	-----------------------------------	------------------------	----------------------	-------------------

Flooring

CARPET

- All Carpeted Areas -A,I,M
- Dining Credit
- Family Credit
- Opt Bedroom 5
- Opt Master Bedroom Bay Window

Study Credit

Carpet Level 4



Carpet Color:
Truly Cultured - 934 Winter Wind
Id: 1BP66B/934



Carpet Cushion:
Vegas 1/2" 6 lb Pad
Id: 12073148/2073148

Area Subtotal(s)

All Carpeted Areas -A,I,M:	\$4,554
Dining Credit:	(\$249)
Family Credit:	(\$348)
Opt Bedroom 5:	\$445
Opt Master Bedroom Bay Window:	\$118
Study Credit:	(\$219)

CARPET SUBTOTAL: \$4,301

TILE

- Bath 2
- Bath 4

Floor Tile Level 6

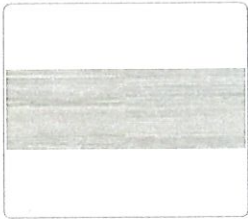

Tile Color:
Elect 12x24 - EL32 Gray
Id: 6E1224/EL32

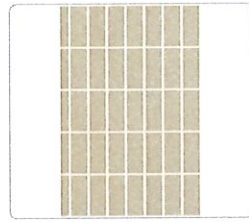

Pattern:
Straight Lay Rectangle Front to Back
Id: 737

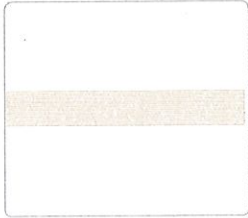

Grout Color:
TEC Power Grout - #949 Silverado
Id: TTECPG/949

<i>Area Subtotal(s)</i>	Bath 2:	\$138
	Bath 4:	\$177

• Bath 2 Opt Shower Floor

Floor Tile Level 6

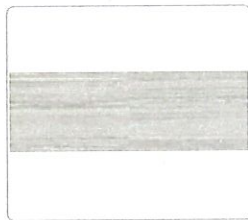

Tile Color:
Elect 12x24 - EL32 Gray
Id: 6E1224/EL32



Pattern:
Straight Lay
Id: 6



Grout Color:
TEC Power Grout - #949 Silverado
Id: TTECPG/949

Bath 2 Opt Shower Floor

↳ Cut to 4x4

<i>Area Subtotal(s)</i>	Bath 2 Opt Shower Floor:	\$64
-------------------------	--------------------------	------

• Bath 3 • Half Bath • Opt Bath 5

Floor Tile Level 6

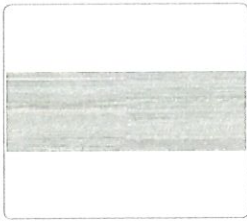

Tile Color:
Elect 12x24 - EL32 Gray
 Id: 6E1224/EL32

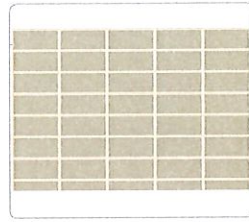

Pattern:
Straight Lay Rectangle Side to Side
 Id: 738

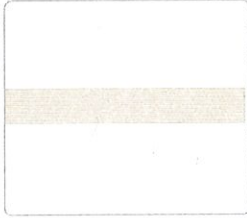

Grout Color:
TEC Power Grout - #949 Silverado
 Id: TTECPG/949

Area Subtotal(s)

Bath 3: **\$123**
 Half Bath: **\$118**
 Opt Bath 5: **\$187**

- Master Bath
- Utility w/Opt Cabinets

Floor Tile Level 7

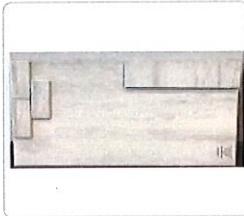

Tile Color:
Mount Claire 12x24 - MC30 Ash
 Id: 6MC124/MC30



Pattern:
Straight Lay Rectangle Front to Back
 Id: 737

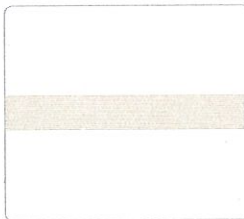

Grout Color:
TEC Power Grout - #949 Silverado
 Id: TTECPG/949

Area Subtotal(s)

Master Bath: **\$1,033**
 Utility w/Opt Cabinets: **\$693**

- Master Bath Shower Floor

Floor Tile Level 12



Tile Color:
Marble Predella Pebble Mosaic (12x12 Mesh) - M024 Lumen White
 Id: 6MPPE/M024

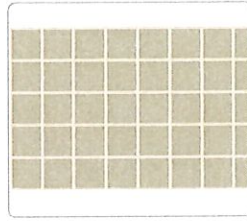

Pattern:
Straight Lay
 Id: 6

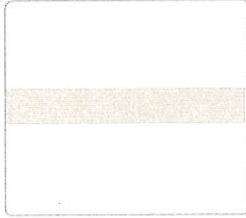

Grout Color:
TEC Power Grout - #949 Silverado
 Id: TTECPG/949

Area Subtotal(s) Master Bath Shower Floor: **\$506**

• Powder

Floor Tile Level 7



Tile Color:
Memoir 12x12 - ME20 Petal Grey
 Id: 6MEM12/ME20

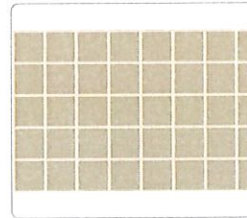

Pattern:
Straight Lay
 Id: 6

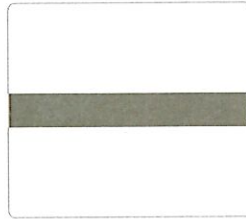

Grout Color:
TEC Power Grout - #927 Light Pewter
 Id: TTECPG/927

Area Subtotal(s) Powder: **\$156**

TILE SUBTOTAL: \$3,195

WOOD

- Butlers Pantry • Dining -I,M • Entry w/ Opt Media Room 1 • Family Room w/Opt Sliding Door • Garage Entry • Kitchen/Breakfast • Mud Room • Storage • Study

Wood Level 5

ADDRESS: 37 North Waterbridge Dr

BUYER: Showcase Home 37 North Waterbridge Dr

INITIAL:

INITIAL:

EFFECTIVE DATE: 11/25/2019

PAGE: 4 of 7



Wood Color:
Coastal Bliss Oak 7" - Seaspray
 Id: 3CB32583/32583-29

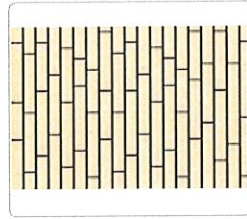

Pattern:
Wood Front to Back
 Id: 719

Area Subtotal(s)

Butlers Pantry:	\$400
Dining -I,M:	\$2,761
Entry w/ Opt Media Room 1:	\$3,836
Family Room w/Opt Sliding Door:	\$7,430
Garage Entry:	\$218
Kitchen/Breakfast:	\$4,262
Mud Room:	\$404
Storage:	\$499
Study:	\$2,536

WOOD SUBTOTAL: \$22,346

Flooring Total: \$29,842

Walls

TILE

- Bath 2 Opt Shower Stall
- Bath 3 Tub Splash
- Bath 4 Tub Splash
- Opt Bath 5 Tub Splash

Wall Tile Level 6

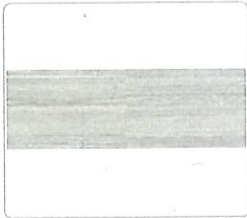

Tile Color:
Elect 12x24 - EL32 Gray
 Id: 6E1224/EL32

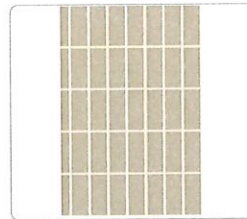

Pattern:
Straight Lay Rectangle Vertical
 Id: 739



Grout Color:
TEC Power Grout - #949 Silverado
 Id: TTECPG/949

Area Subtotal(s)

Bath 2 Opt Shower Stall:	\$559
Bath 3 Tub Splash:	\$318
Bath 4 Tub Splash:	\$318
Opt Bath 5 Tub Splash:	\$318

- Butlers Pantry Back Splash
- Kitchen Back Splash w/Opt 48" Upgraded Hood

Wall Tile Level 10



Tile Color:
Hawthorne Beveled Wall 4x12 - HT15
 Refined White
 Id: 6HBW/HT15



Pattern:
S 67 Rectangular Staggered
 (Horizontal)
 Id: 715

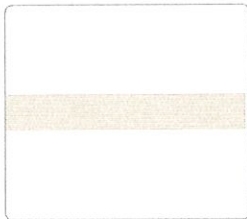

Grout Color:
TEC Power Grout - #949 Silverado
 Id: TTECPG/949

Area Subtotal(s)

Butlers Pantry Back Splash:	\$291
Kitchen Back Splash w/Opt 48" Upgraded Hood:	\$581

- Master Bath Freestanding Tub Splash
- Master Bath Shower Stall

Wall Tile Level 7

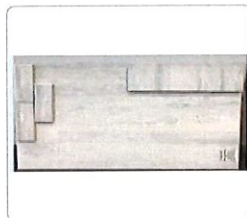

Tile Color:
Mount Claire 12x24 - MC30 Ash
 Id: 6MC124/MC30

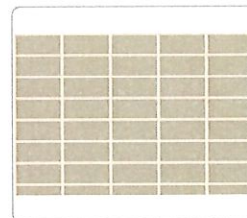

Pattern:
Straight Lay Rectangle Horizontal
 Id: 740



Grout Color:
TEC Power Grout - #949 Silverado
 Id: TTECPG/949

Area Subtotal(s)

Master Bath Freestanding Tub Splash: \$133
Master Bath Shower Stall: \$836

TILE SUBTOTAL: \$3,354

Walls Total: \$3,354

Flooring

TILE

- Bath 2
- Bath 4

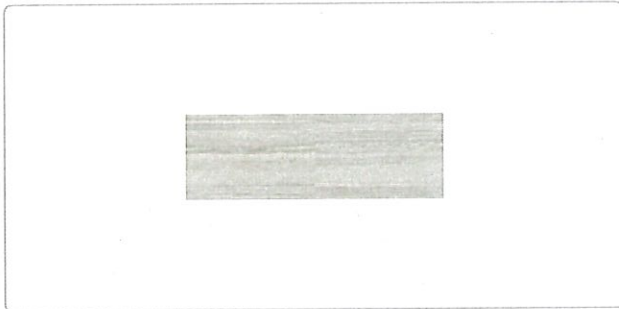

Tile Color: Elect 12x24 - EL32 Gray
Id: 6E1224/EL32

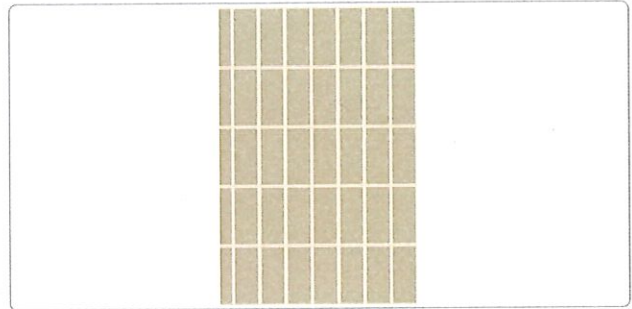

Pattern: Straight Lay Rectangle Front to Back



Grout Color: TEC Power Grout - #949 Silverado
Id: TTECPG/949

• Bath 2 Opt Shower Floor

↳  Cut to 4x4

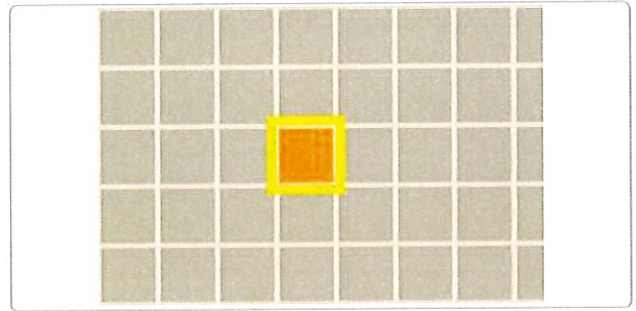
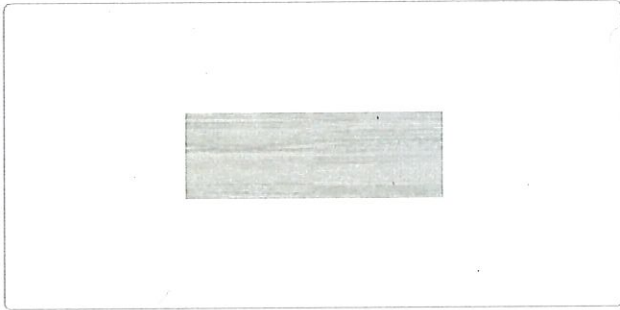

Tile Color: Elect 12x24 - EL32 Gray

Id: 6E1224/EL32

Pattern: Straight Lay

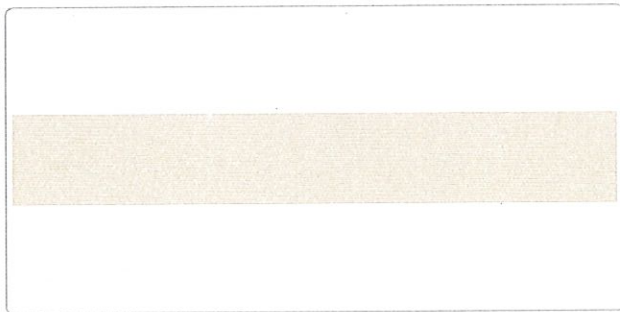

Grout Color: TEC Power Grout - #949 Silverado

Id: TTECPG/949

- Bath 3
- Half Bath
- Opt Bath 5

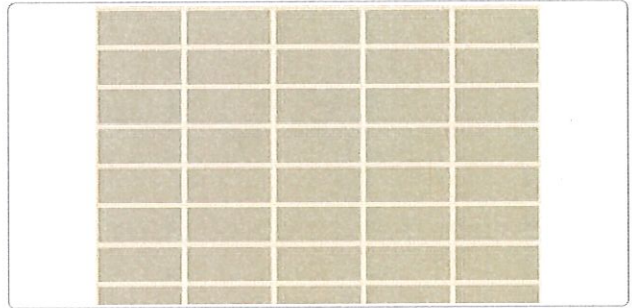
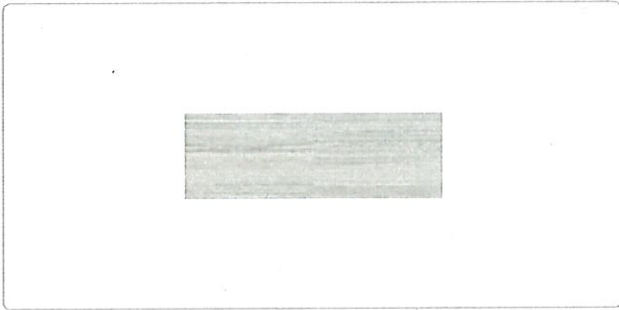

Tile Color: Elect 12x24 - EL32 Gray
Id: 6E1224/EL32

Pattern: Straight Lay Rectangle Side to Side



Grout Color: TEC Power Grout - #949 Silverado
Id: TTECPG/949

- Master Bath
- Utility w/Opt Cabinets

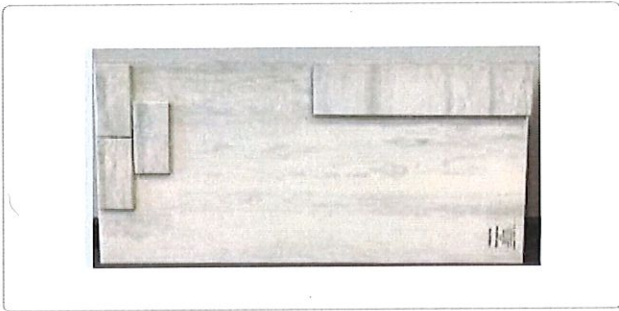

Tile Color: Mount Claire 12x24 - MC30 Ash
 Id: 6MC124/MC30

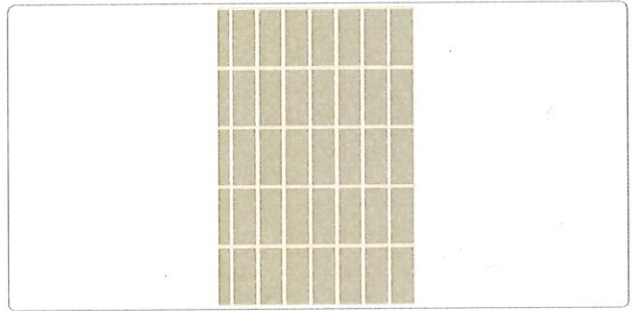

Pattern: Straight Lay Rectangle Front to Back



Grout Color: TEC Power Grout - #949 Silverado
 Id: TTECPG/949

• Master Bath Shower Floor



Tile Color: Marble Predella Pebble Mosaic (12x12 Mesh) - M024
Lumen White
Id: 6MPPE/M024

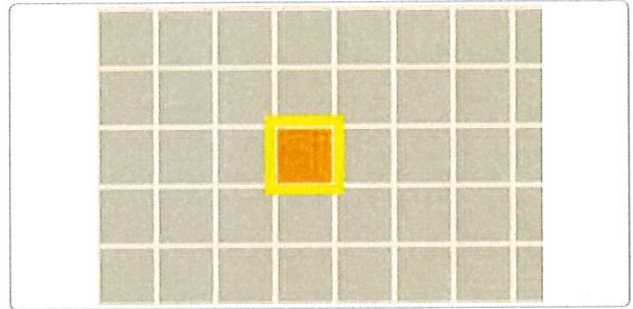

Pattern: Straight Lay

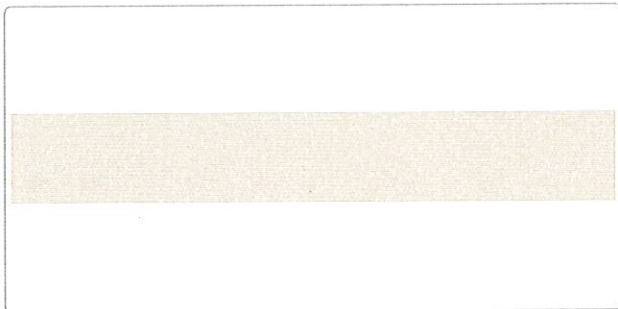

Grout Color: TEC Power Grout - #949 Silverado
Id: TTECPG/949

• Powder



Tile Color: Memoir 12x12 - ME20 Petal Grey
Id: 6MEM12/ME20

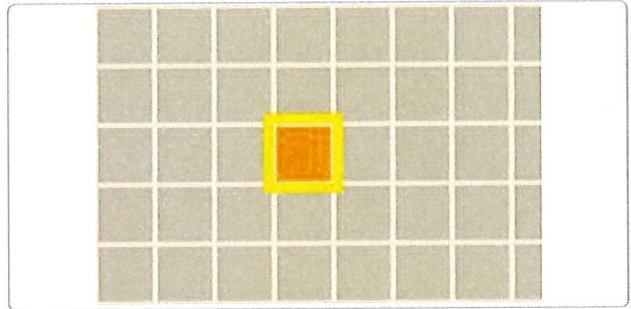

Pattern: Straight Lay

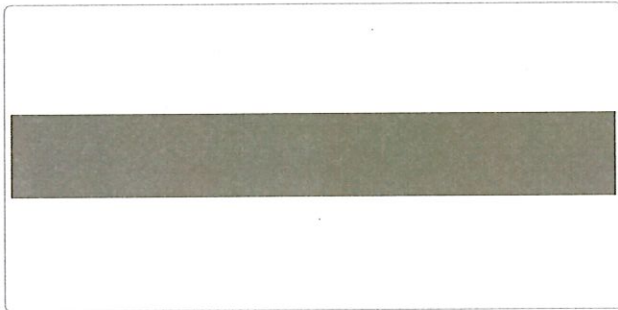

Grout Color: TEC Power Grout - #927 Light Pewter
Id: TTECPG/927

WOOD

- Butlers Pantry
- Dining -I,M
- Entry w/ Opt Media Room 1
- Family Room w/Opt Sliding Door
- Garage Entry
- Kitchen/Breakfast
- Mud Room
- Storage
- Study

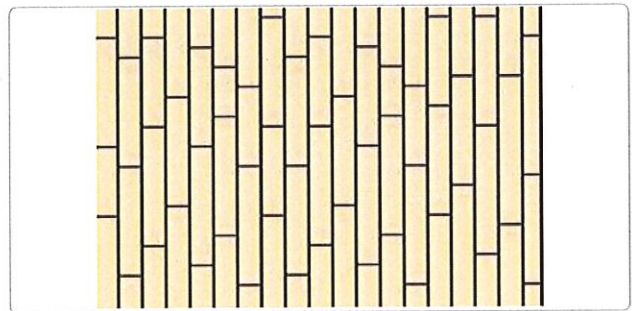
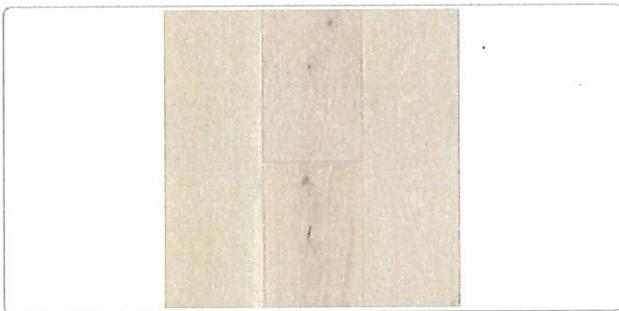

Wood Color: Coastal Bliss Oak 7" - Seaspray
Id: 3CB32583/32583-29

Pattern: Wood Front to Back

Walls

TILE

- Bath 2 Opt Shower Stall
- Bath 3 Tub Splash
- Bath 4 Tub Splash
- Opt Bath 5 Tub Splash

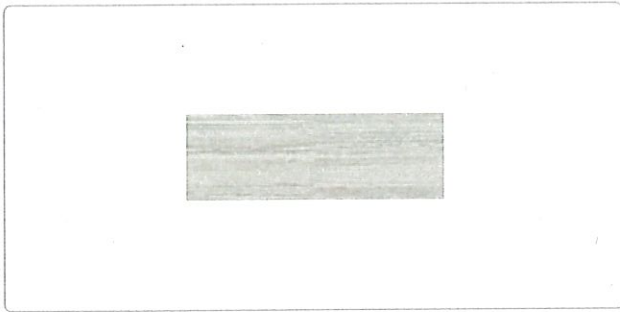

Tile Color: Elect 12x24 - EL32 Gray
Id: 6E1224/EL32

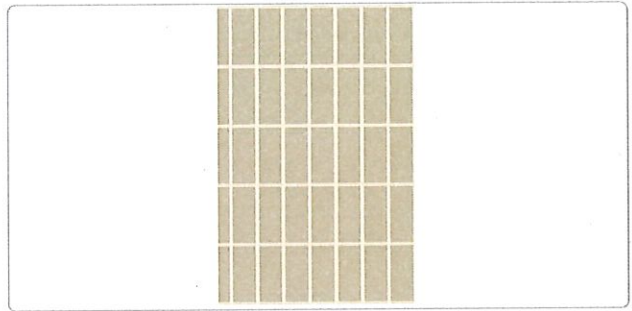

Pattern: Straight Lay Rectangle Vertical



Grout Color: TEC Power Grout - #949 Silverado
Id: TTECPG/949

- Butlers Pantry Back Splash
- Kitchen Back Splash w/Opt 48" Upgraded Hood

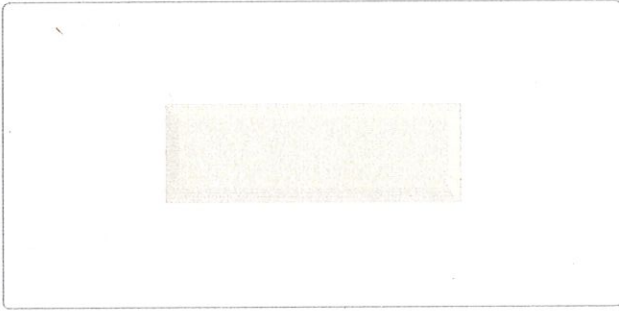

Tile Color: Hawthorne Beveled Wall 4x12 - HT15 Refined White
Id: 6HBW/HT15



Pattern: S 67 Rectangular Staggered (Horizontal)



Grout Color: TEC Power Grout - #949 Silverado
Id: TTECPG/949

- Master Bath Freestanding Tub Splash
- Master Bath Shower Stall

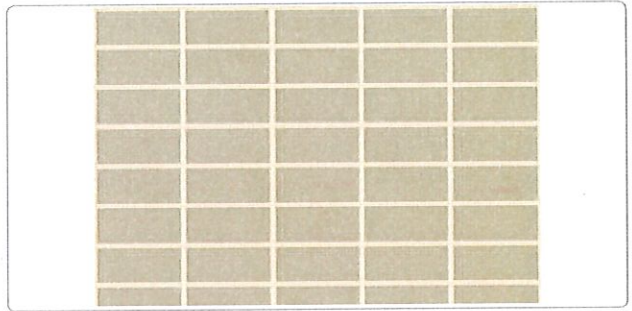
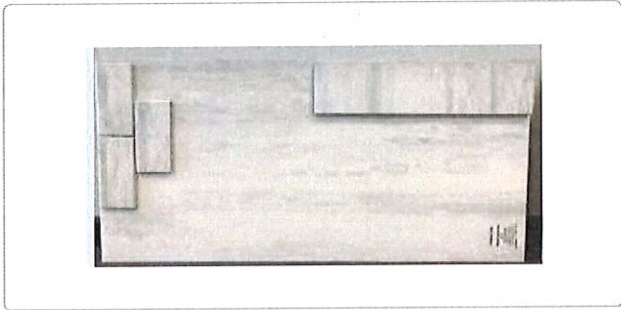

Tile Color: Mount Claire 12x24 - MC30 Ash
Id: 6MC124/MC30

Pattern: Straight Lay Rectangle Horizontal

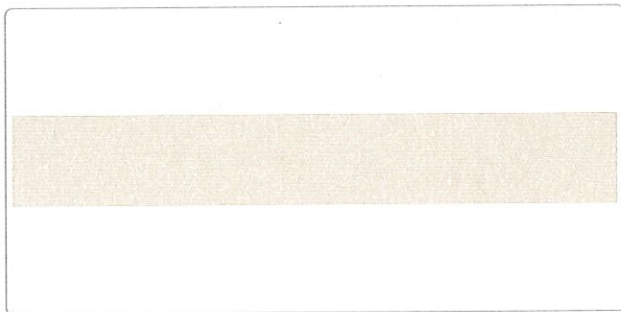

Grout Color: TEC Power Grout - #949 Silverado
Id: TTECPG/949



Buyer Selections Summary

Darling Homes Houston - 12/23/2019 8:04:24 AM

BUYER: Showcase Home 37 North Waterbridge Dr	DESIGNER: Jeannine Riley	SALES COUNSELOR: Other/Unknown	CATALOG DATE: 12/11/2019 3:50:50 PM	JOB NUMBER: Q-39764
---	------------------------------------	--	---	-------------------------------

ADDRESS: 37 North Waterbridge Dr	LOT / BLOCK:	COMMUNITY: Woodlands 80	SERIES: Luxe	PLAN: 7247	ELEV: M
---	---------------------	-----------------------------------	------------------------	----------------------	-------------------

SELECTIONS SUMMARY	TOTAL: \$33,196
---------------------------	------------------------

Flooring	
↳ Carpet	\$4,301
↳ Tile	\$3,195
↳ Wood	\$22,346
Walls	\$3,354

Printed Name: _____ Signature: _____ Date: _____

Printed Name: _____ Signature: _____ Date: _____

Flooring Redline Report

DARLING HOMES HOUSTON

Plan: 7247
 Revision: 04/04/18 R0

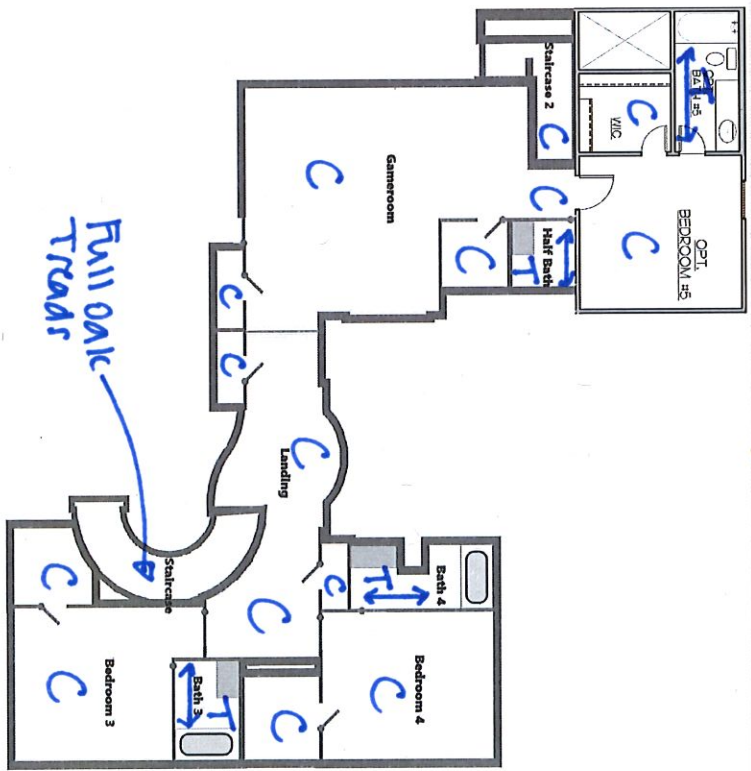
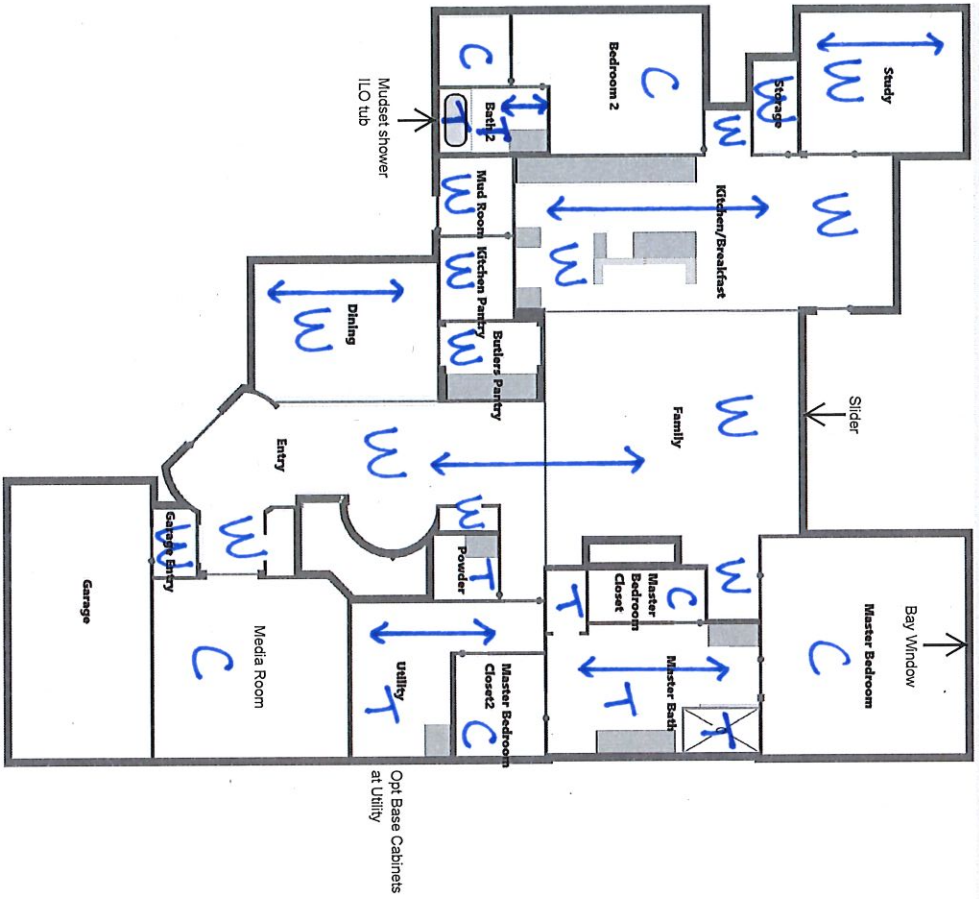

37 North Waterbridge Dr | Woodlands 80 | Showcase

12/23/19

Accepted By: _____

Date: _____

Customer: Darling Homes-7247-Bid 123679
Address of Plan: 37 North Waterbridge Drive
City: Conroe

Date: 12/17/19
Page: 1 of 8
Drawn By: 15

Customer Approval:
THIS DRAWING IS AN INTERPRETATION OF THE ACTUAL DRAWING, AND IS THE PROPERTY OF KENT MOORE CABINETS LTD. THIS DRAWING IS INTENDED SOLELY FOR THE USE BY CLIENTS OF KENT MOORE CABINETS LTD. ALL DIMENSIONS SUBJECT TO CHANGE WITH VERIFICATION OF FIELD MEASUREMENTS.

ISLAND

36" TOP W/DOC/WSTK (36WSTK)

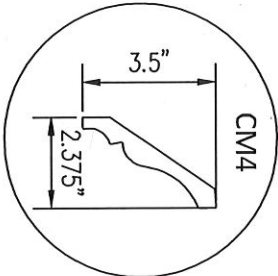
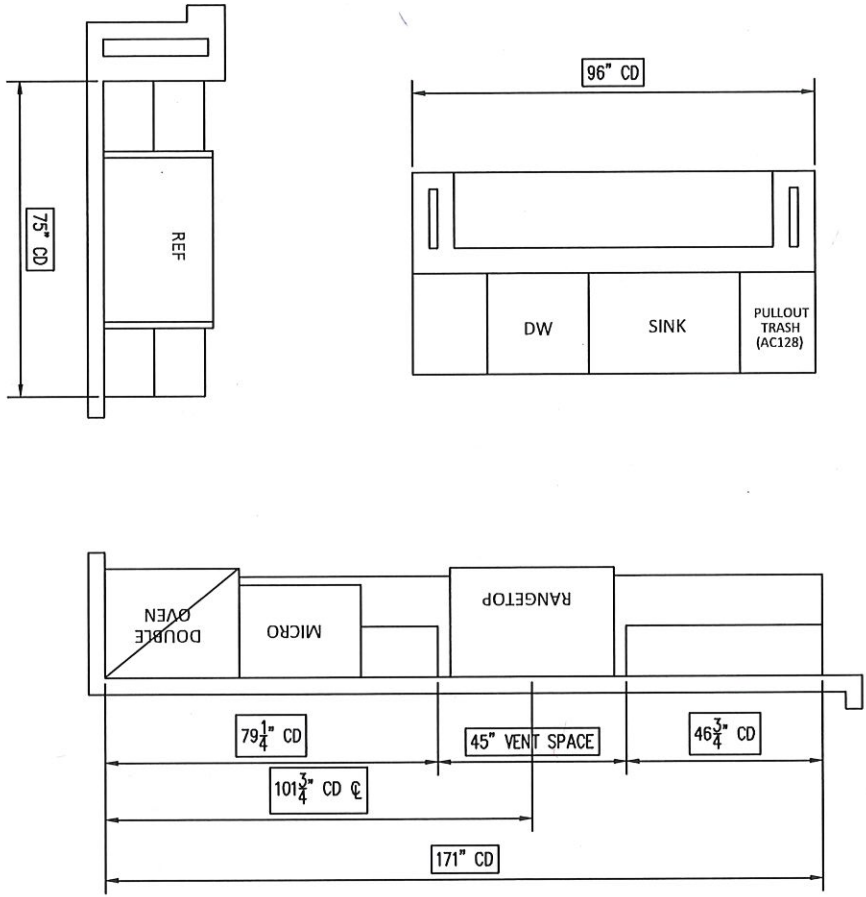

36" TOP W/DOC/WSTK (36WSTK)

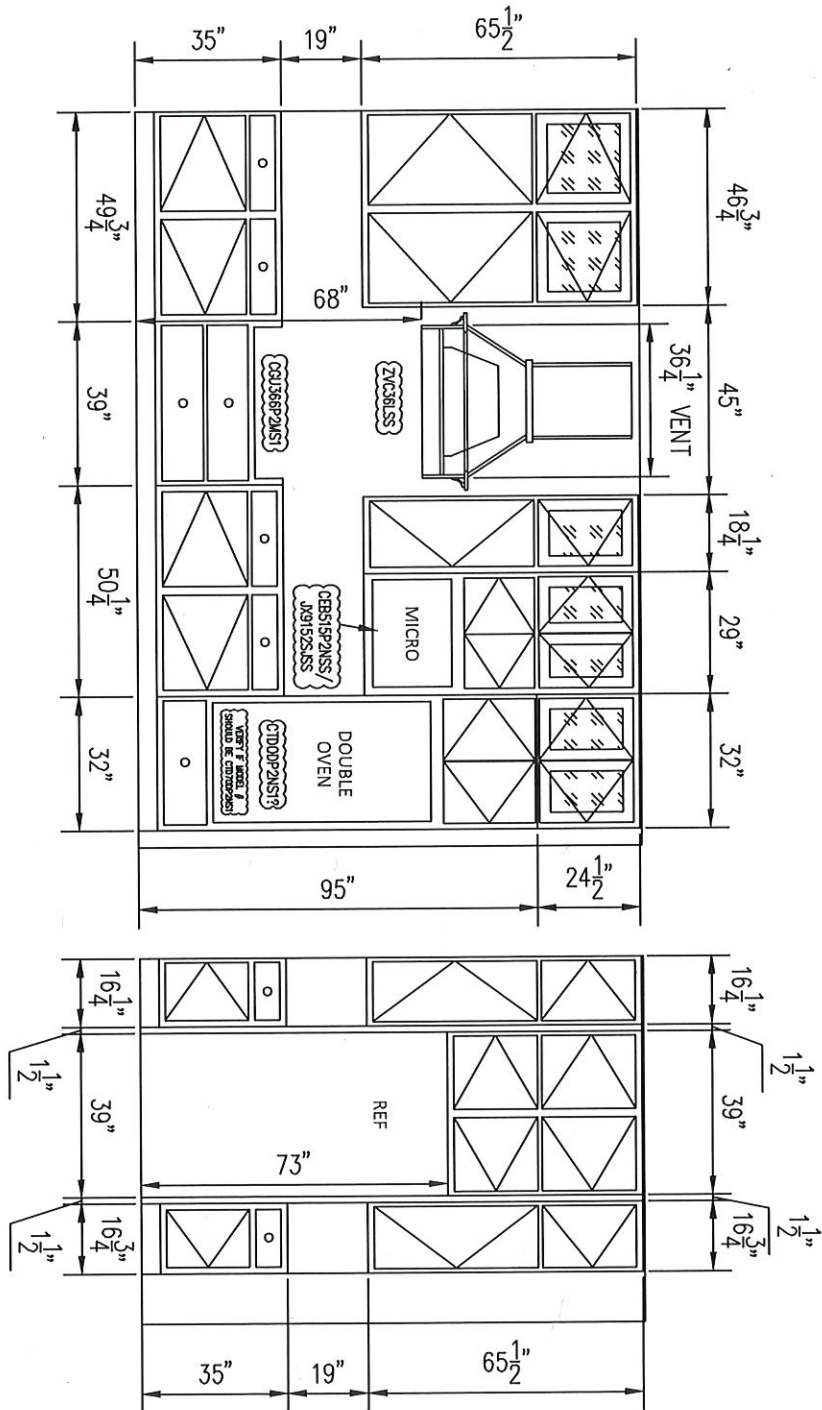

Kent Moore
Cabinets Ltd.

Customer: Darling Homes-7247-Bid 123679
 Address of Plan: 37 North Waterbridge Drive
 City: Conroe
 Date: 12/17/19
 Page: 2 of 8
 Drawn By: 15
 Customer Approval: _____
 THIS DRAWING IS AN INTERPRETATION OF THE ACTUAL DRAWING, AND IS THE PROPERTY OF KENT MOORE CABINETS LTD. THIS DRAWING IS INTENDED SOLELY FOR THE USE BY CLIENTS OF KENT MOORE CABINETS LTD. ALL DIMENSIONS SUBJECT TO CHANGE WITH VERIFICATION OF FIELD MEASUREMENTS.

Kent Moore
Cabinets Ltd.

Customer: Darling Homes-7247-Bid 123679
Address of Plan: 37 North Waterbridge Drive
City: Conroe

Date: 12/17/19 Page: 3 of 8 Drawn By: 15

Customer Approval:

THIS DRAWING IS AN INTERPRETATION OF THE ACTUAL DRAWING, AND IS THE PROPERTY OF KENT MOORE CABINETS LTD. THIS DRAWING IS INTENDED SOLELY FOR THE USE BY CLIENTS OF KENT MOORE CABINETS LTD. ALL DIMENSIONS SUBJECT TO CHANGE WITH VERIFICATION OF FIELD MEASUREMENTS.

ISLAND

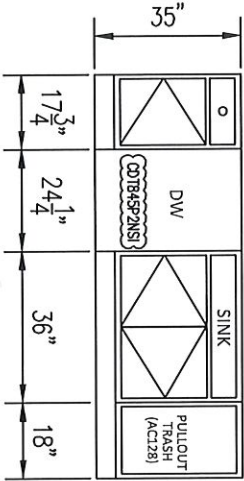
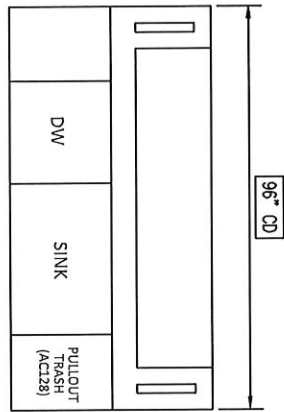

Customer: Darling Homes-7247-Bid 123679
Address of Plan: 37 North Waterbridge Drive
City: Conroe

Date: 12/17/19
Page: 4 of 8
Drawn By: 15

Customer Approval:

THIS DRAWING IS AN INTERPRETATION OF THE ACTUAL DRAWING, AND IS THE PROPERTY OF KENT MOORE CABINETS LTD. THIS DRAWING IS INTENDED SOLELY FOR THE USE BY CLIENTS OF KENT MOORE CABINETS LTD. ALL DIMENSIONS SUBJECT TO CHANGE WITH VERIFICATION OF FIELD MEASUREMENTS.

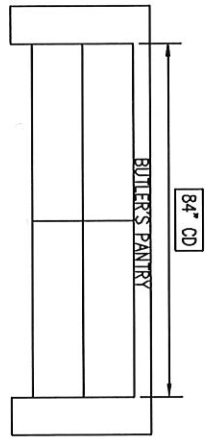
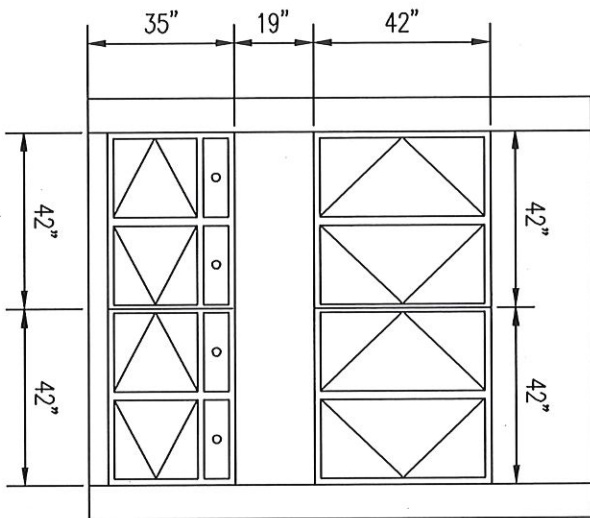

BUTLER'S PANTRY

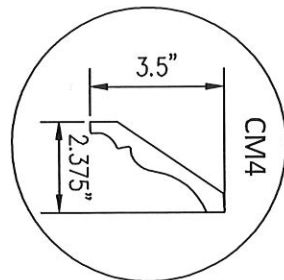

Customer: Darling Homes-7247-Bid 123679
 Address of Field: 37 North Waterbridge Drive
 City: Conroe

Date: 12/17/19 Page: 5 of 8
 Drawn By: 15

Customer Approval:

THIS DRAWING IS AN INTERPRETATION OF THE ACTUAL DRAWING AND IS THE PROPERTY OF KENT MOORE CABINETS LTD. THIS DRAWING IS INTENDED SOLELY FOR THE USE BY CLIENTS OF KENT MOORE CABINETS LTD. ALL DIMENSIONS SUBJECT TO CHANGE WITH VERIFICATION OF FIELD MEASUREMENTS.

MASTER BATH

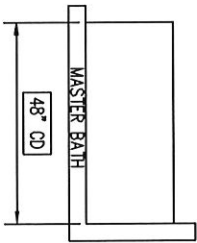
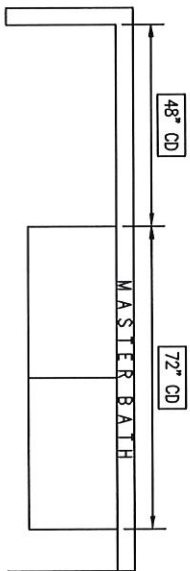
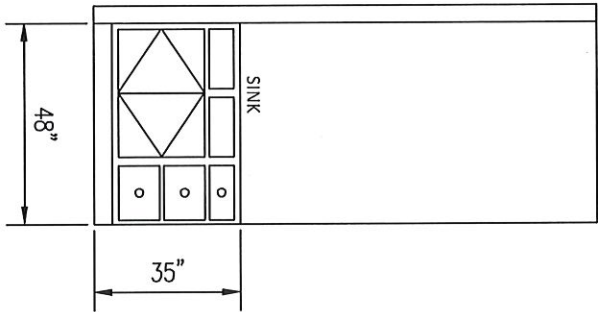
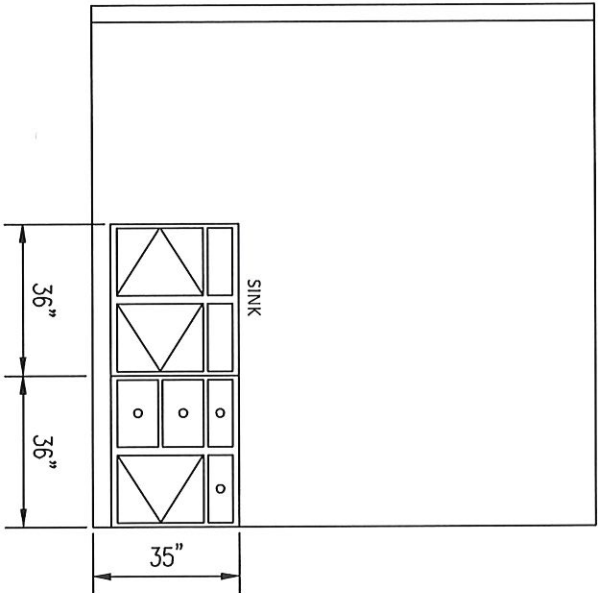

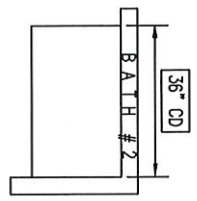

BATH # 2

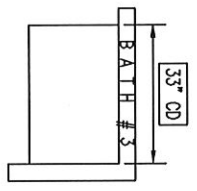

BATH # 3

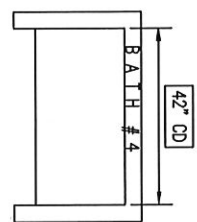

BATH # 4

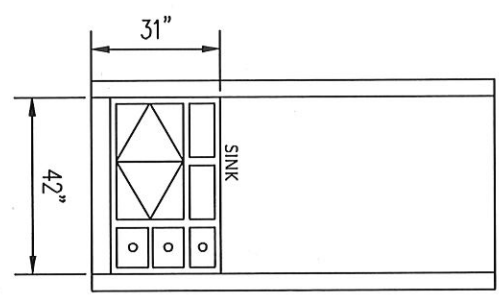
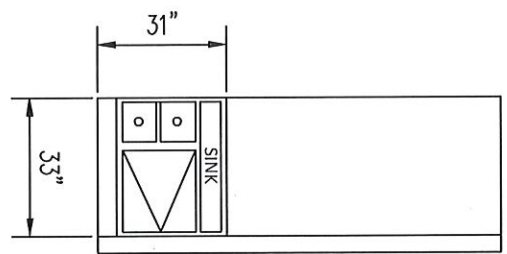
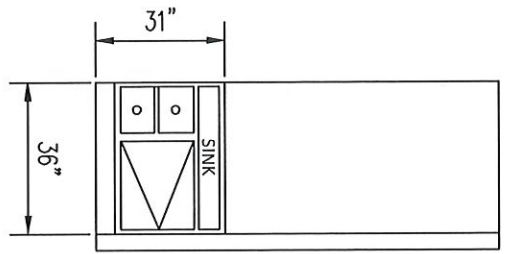

Customer: Darling Homes-7247-Bid 123679
 Address of Plan: 37 North Waterbridge Drive
 City: Conroe
 Date: 12/17/19
 Page: 6 of 8
 Drawn By: 15

Customer Approval:
 THIS DRAWING IS AN INTERPRETATION OF THE ACTUAL DRAWING, AND IS THE PROPERTY OF KENT MOORE CABINETS LTD. THIS DRAWING IS INTENDED SOLELY FOR THE USE BY CLIENTS OF KENT MOORE CABINETS LTD. ALL DIMENSIONS SUBJECT TO CHANGE WITH VERIFICATION OF FIELD MEASUREMENTS.

Customer: **Darling Homes-7247-Bid 123679**
Address of Plan: **37 North Waterbridge Drive**
City: **Conroe**

Date: **12/17/19** Page: **7 of 8** Drawn By: **15**

Customer Approval:

THIS DRAWING IS AN INTERPRETATION OF THE ACTUAL DRAWING, AND IS THE PROPERTY OF KENT MOORE CABINETS LTD. THIS DRAWING IS INTENDED SOLELY FOR THE USE BY CLIENTS OF KENT MOORE CABINETS LTD. ALL DIMENSIONS SUBJECT TO CHANGE WITH VERIFICATION OF FIELD MEASUREMENTS.

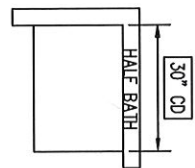

HALF BATH

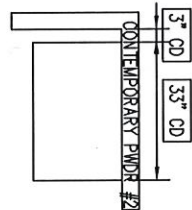

CONTEMPORARY POWDER

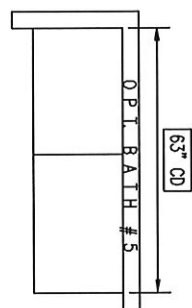

OPT. BATH #5

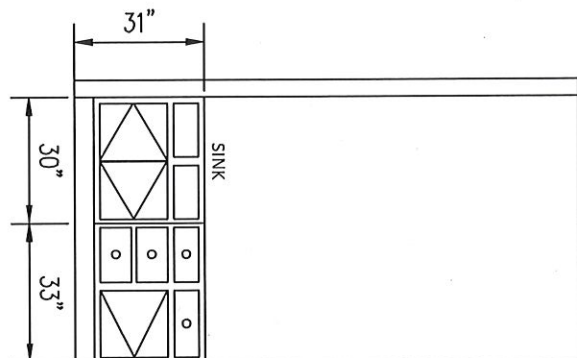
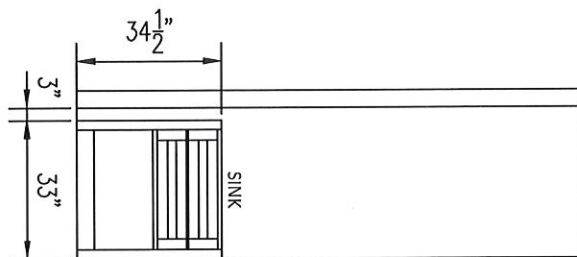
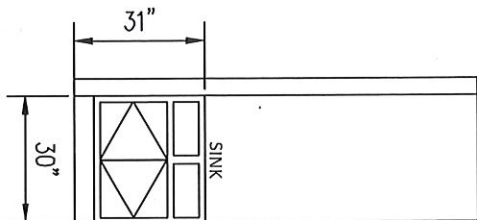

Customer: Darling Homes-7247-Bid 123679
Address of Plan: 37 North Waterbridge Drive
City: Conroe

Date: 12/17/19 Page: 8 of 8 Drawn By: 15

Customer Approval: THIS DRAWING IS AN INTERPRETATION OF THE ACTUAL DRAWING, AND IS THE PROPERTY OF KENT MOORE CABINETS LTD. THIS DRAWING IS INTENDED SOLELY FOR THE USE BY CLIENTS OF KENT MOORE CABINETS LTD. ALL DIMENSIONS SUBJECT TO CHANGE WITH VERIFICATION OF FIELD MEASUREMENTS.

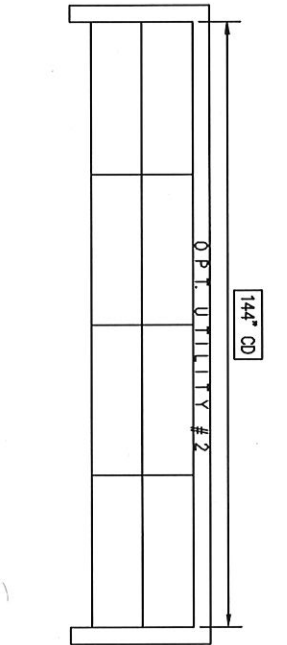
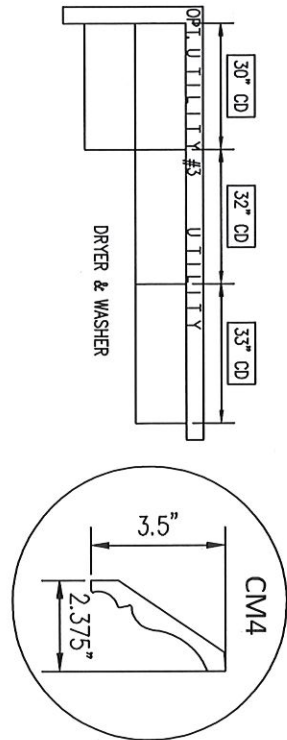
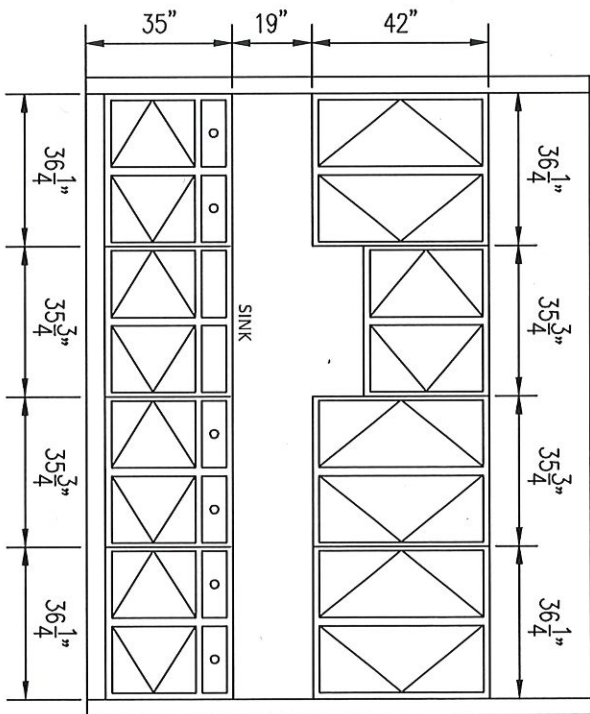
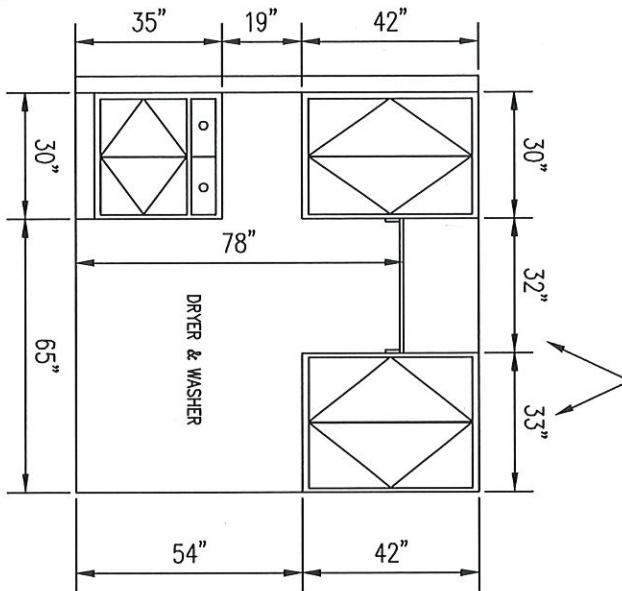

37 North Waterbridge Dr
Cabinet Door Styles

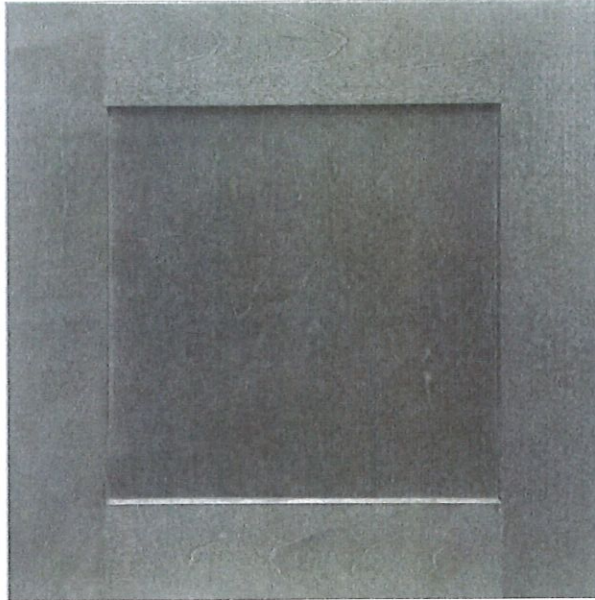

Groveland - Shaker Flat Panel

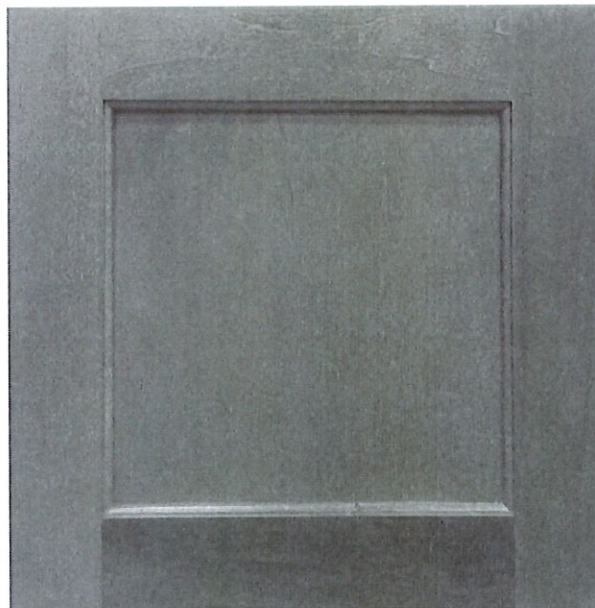

Lexington - Flat Panel

37 North Waterbridge Dr Appliances



Model #: CGU366P2MS1
GE Cafe#™ Series 36" Gas
Rangetop



Model#: CT9550SHSS
GE Cafe#™ Series 30" Built-In
Double Convection Wall Oven

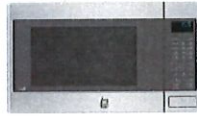

Trim Kit: JX9152SJSS
Model#: CEB1599SJSS
GE Cafe#™ Series 1.5 Cu. Ft.
Countertop
Convection/Microwave Oven

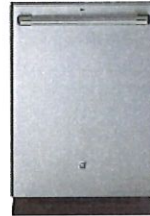

Model #: CDT836P2MS1
GE Cafe#™ Series Stainless
Interior Built-In Dishwasher with
Hidden Controls



Model#: ZVC36LSS
Monogram 36" Custom Hood
Insert

37 North Waterbridge Dr
Kitchen & Utility Sinks



**Blanco Single
Bowl**

**Color:
Metallic
Gray**

SG8505

**Overall
Dimensions:
33 1/2" X 22" X 9 1/2"**



Elmont

SS2513

**Overall
Dimensions:
OD: 22 3/4" X 17 1/2"
ID: 21" X 15 3/4"
Height: 8 3/4"
Gauge: 16
Single Bowl U/M**



Terra

Color
-White

PS7505

Overall dimensions:
19 5/8" X 15 5/16"
Height: 7 1/2 "
U/M

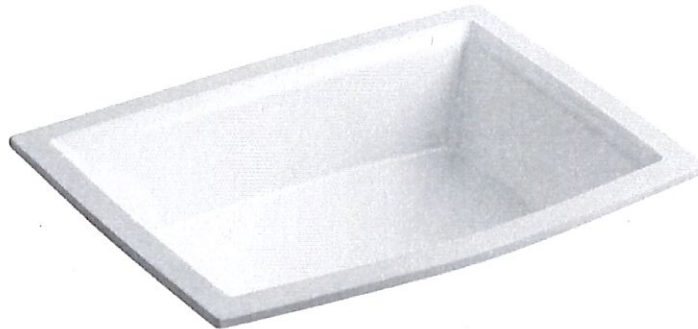

Caxton® Oval **COLOR:** White
17" x 14" under-mount bathroom sink

Caxton has a simple, streamlined design that's as versatile as it is attractive. This easy-to-clean sink combines the sleek look of an integrated basin with a timeless design that suits both traditional and modern bathroom decors. Caxton creates a sleek transition from the smooth oval basin to just about any solid-surface countertop.

FEATURES

- Oval basin with unglazed underside.
- Overflow drain.
- Fits standard 14- x 17-inch countertop cutout.



Caxton	Color	Overall Dimensions
U/M	-White	OD: 18.5"X15"X8"
	PS7504	ID: 17"X13.5"X 6"



Align
Spot Resist Stainless
5923SRS



Moen Integra 6731SSRS



Brantford Brushed Nickel

37 North Waterbridge Dr
Bath Hardware

 Darling
HOMES

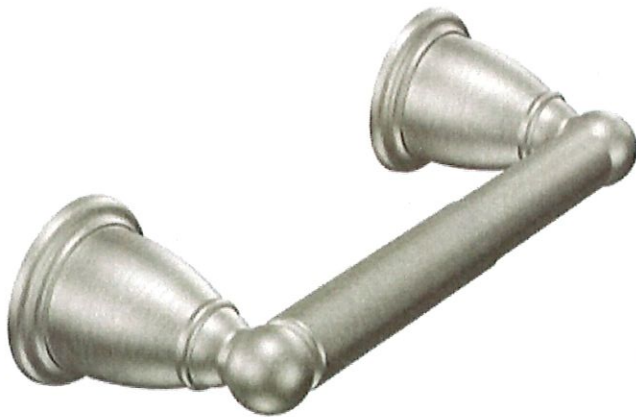

37 North Waterbridge Dr
Freestanding Tub



RENWIL®
The Hudson

Dimensions: 69L x 33W x 27H



****Faucet for Display Only****
Deck Mount Only

37 North Waterbridge Dr
Mirror Frame

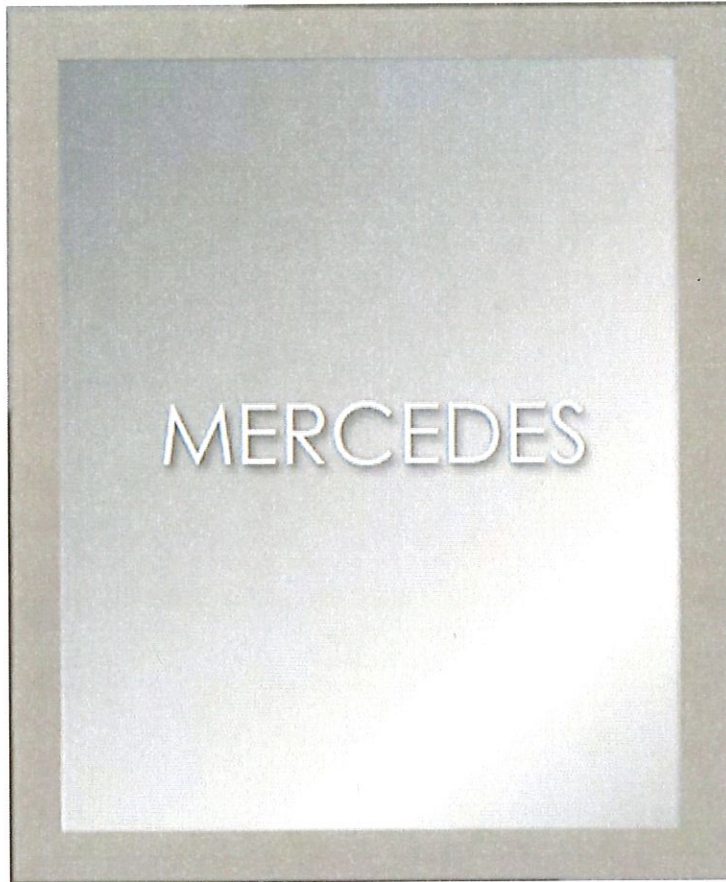

37 North Waterbridge Dr
Stair Parts

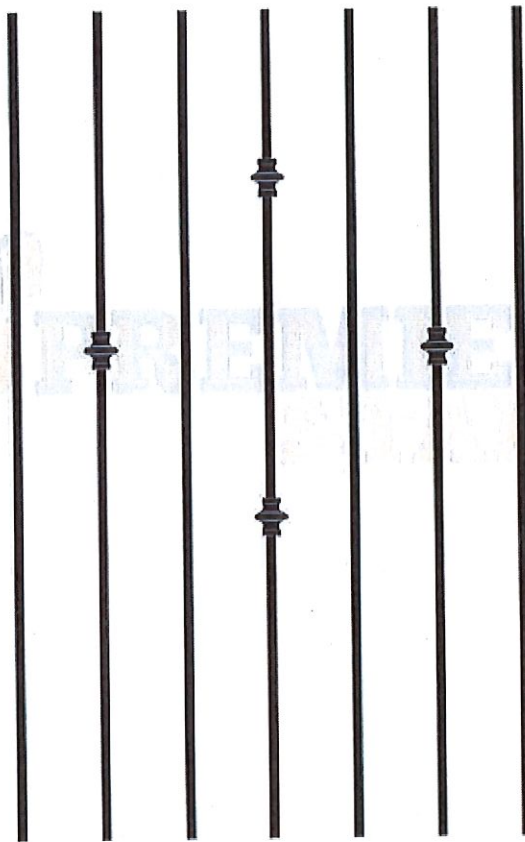

P-10B



37 North Waterbridge Dr Lighting Package



Joelson™ - I

Brushed Nickel Finish with Satin-Etched Opal Glass
 Fixture Per Community Feature Sheet
 Option Code: LTFX1083
 (Bath Vanities in Chrome Finish)



43924 NI
 High Entry 17ft
 9-Light, 100W
 W 32", H 1.33', CvrL 8.71'



43923 NI
 Dining
 5-Light, 100W
 W 24", H 1.93', CvrL 5.0'



43925 NI
 Mid Entry 13-16ft
 3-Light, 100W
 W 17.25", H 1.16.75', CvrL 9.1'



43926 NI
 Bedroom/Study
 2-Light, 60W
 W 10.5", H 1.6'



43940WHL ED10
 Nicely Bath/Hall/Closets
 (plan specific)
 10W, 820 Lm, 90 CRI, 3000 K
 W 13", H 1.25'



43925 NI
 Low Entry 8-11ft
 3-Light, 100W
 W 14.25", H 1.1.25'



43921 NI
 Wall/Middle Sconce
 1-Light, 100W
 W 5", H 1.8.25'
 Cvt. 5.25'

37 North Waterbridge Dr Ceiling Fan & Pendant Light



Starkk

300173 NI

Interior Ceiling Fan with Light
Brushed Nickel Finish
with Satin Etched Glass

(1) E-1175W JD Lamp Included

52" Blade Sweep

Reversible Silver/Walnut Blades

Reversible, 3-Speeds, Pull Chain Control

Option Code: ELCF0085



KICHLER.

Everly Collection

Everly - 1 Light Pendant - Brushed Nickel

42046NICS (Brushed Nickel)

Product Description:

The design of this 1 light pendant from Everly collection is based on decorative blown glass containers. It features clear seedy glass and is made memorable with the use of an optional vintage squirrel cage filament bulb. Contemporary or traditional, this pendant can be used singularly or in multiples to elevate every room.



37 North Waterbridge Dr
Interior Door



CAMBRIDGE™ SMOOTH Interior Door

Squared panels give this door a clean, precise look, while its Ovolo sticking profile adds dimension. Its simplicity adds to its versatility, making this a great choice for most home styles. For noise reduction, choose the ProCore® solid core option.





**Addison
handleset**

Shown for style only



Accent lever



**Satin Nickel
(619)**

37 North Waterbridge Dr
Overall Home Selections

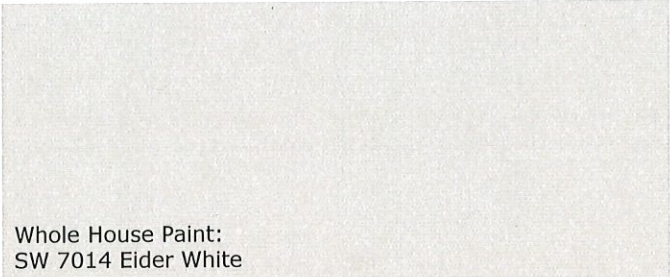

Whole House Paint:
SW 7014 Eider White

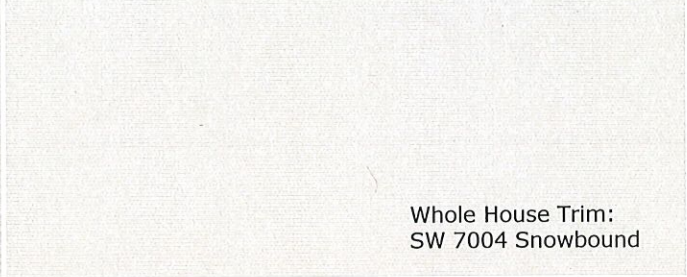
A rectangular swatch of a light, off-white paint with a subtle, fine-grained texture.

Whole House Trim:
SW 7004 Snowbound

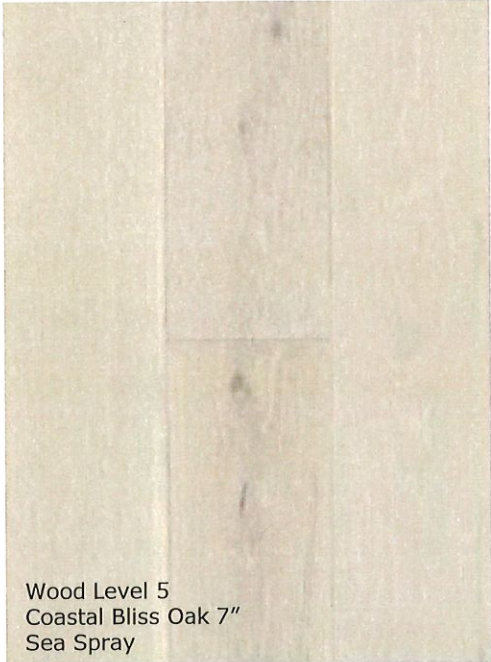
A rectangular swatch of a light, off-white paint with a more pronounced, woven fabric-like texture.

Wood Level 5
Coastal Bliss Oak 7"
Sea Spray

A vertical rectangular swatch of light-colored wood with a natural grain pattern, showing some darker spots and knots.

Carpet Level 4
Truly Cultured - Winter Wind

A rectangular swatch of a light-colored, textured carpet with a dense, irregular pile.

37 North Waterbridge Dr Kitchen Selections

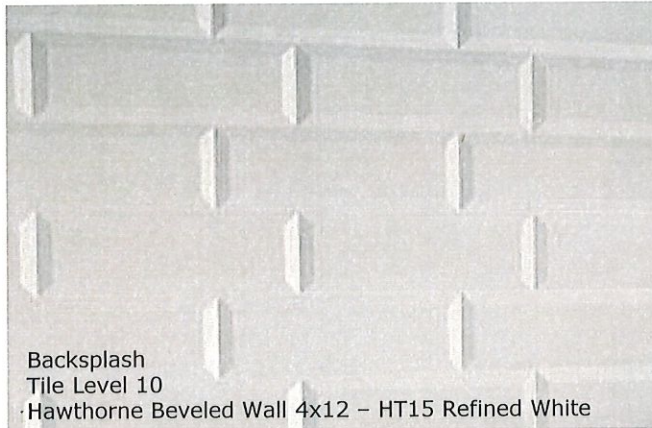

Backsplash
Tile Level 10
Hawthorne Beveled Wall 4x12 - HT15 Refined White

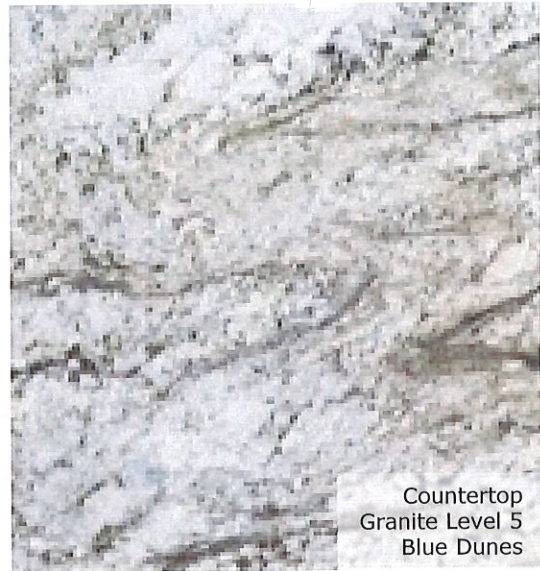

Countertop
Granite Level 5
Blue Dunes

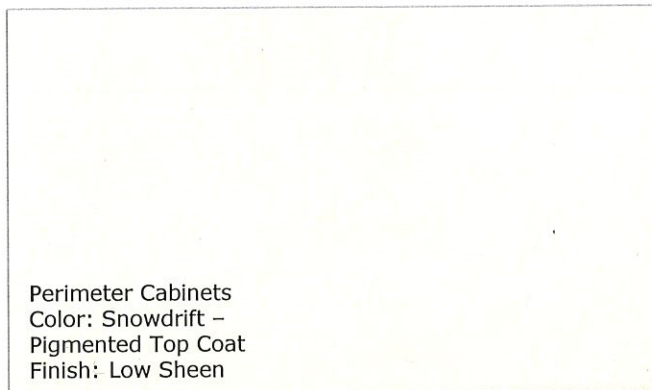

Perimeter Cabinets
Color: Snowdrift -
Pigmented Top Coat
Finish: Low Sheen

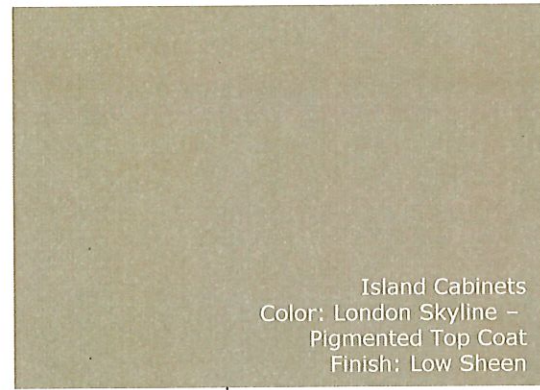

Island Cabinets
Color: London Skyline -
Pigmented Top Coat
Finish: Low Sheen

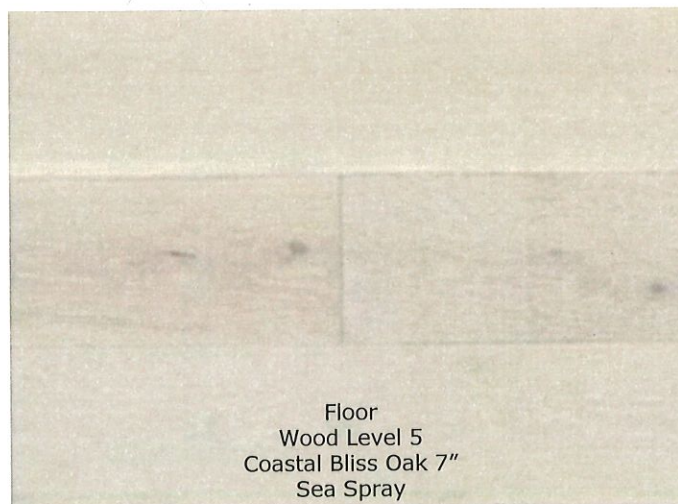

Floor
Wood Level 5
Coastal Bliss Oak 7"
Sea Spray

37 North Waterbridge Dr
Master Bath Selections



Countertop
Granite Level 6
Blue Bonnet

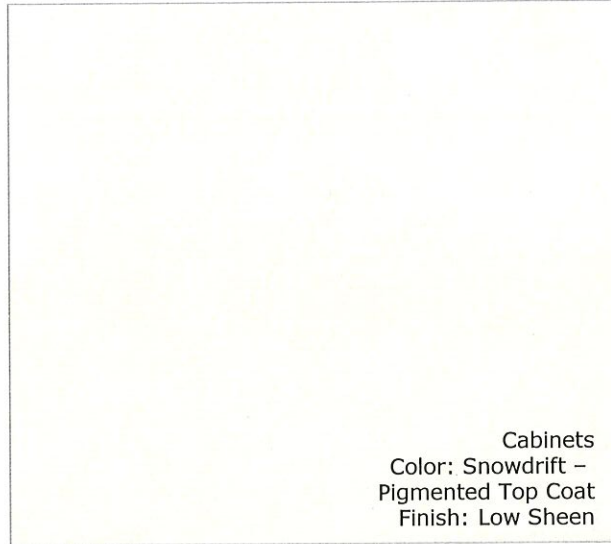

Cabinets
Color: Snowdrift -
Pigmented Top Coat
Finish: Low Sheen

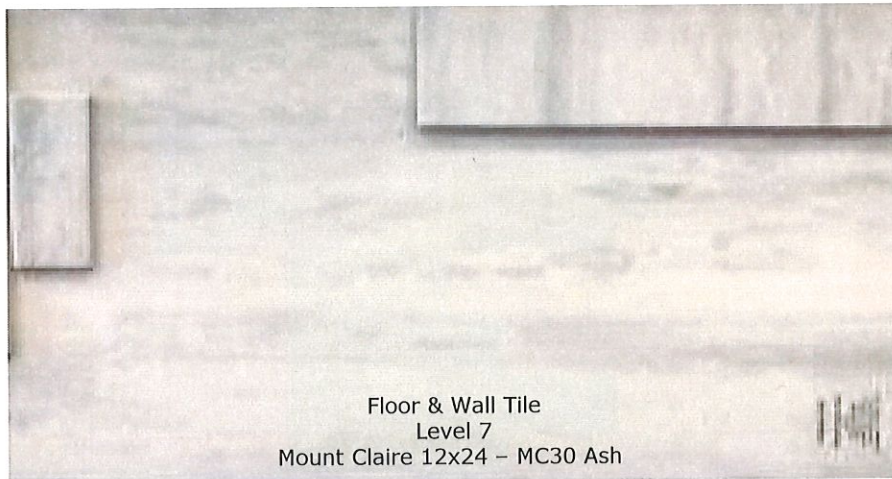

Floor & Wall Tile
Level 7
Mount Claire 12x24 - MC30 Ash



Shower Floor
Level 12
Marble Predella Pebble Mosaic
(12x12 Mesh) - M024 Lumen White

37 North Waterbridge Dr
Secondary Baths Selections

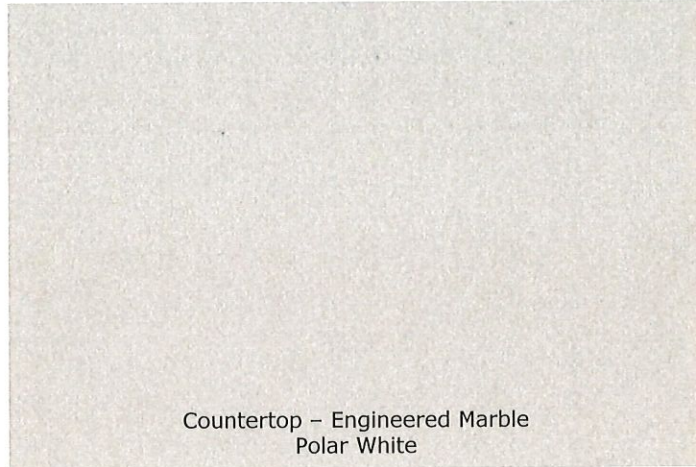

Countertop – Engineered Marble
Polar White

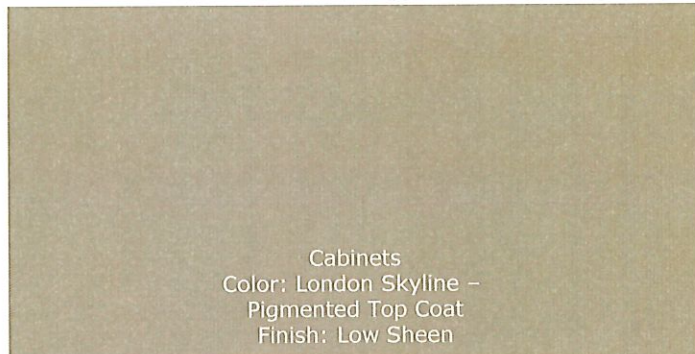

Cabinets
Color: London Skyline –
Pigmented Top Coat
Finish: Low Sheen

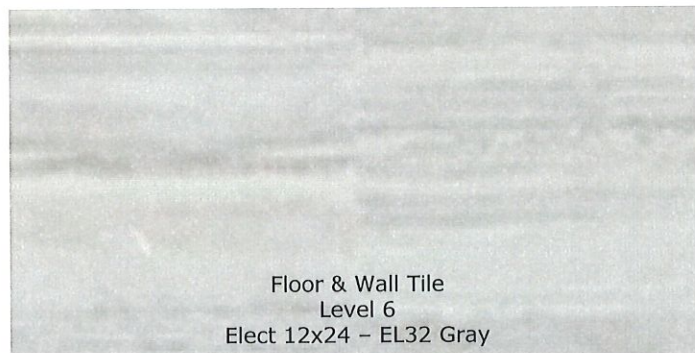

Floor & Wall Tile
Level 6
Elect 12x24 – EL32 Gray

37 North Waterbridge Dr
Powder Selections

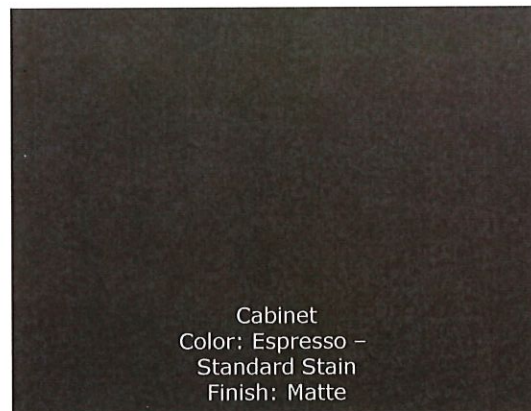
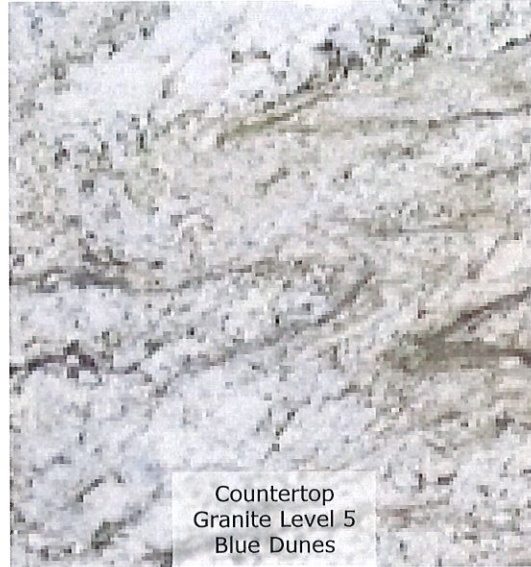

37 North Waterbridge Dr
Utility Selections

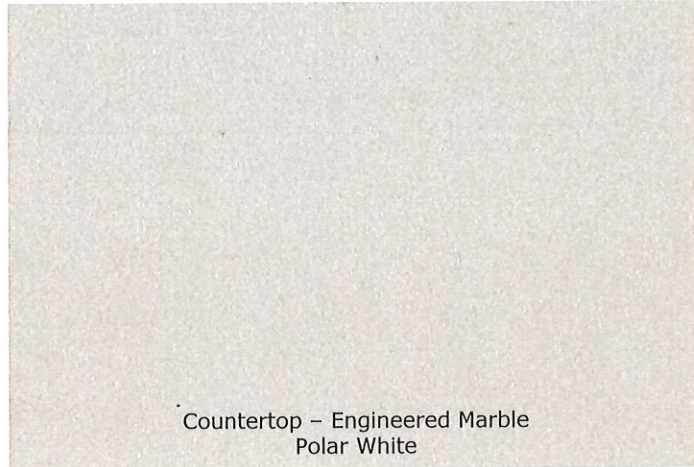

Countertop – Engineered Marble
Polar White

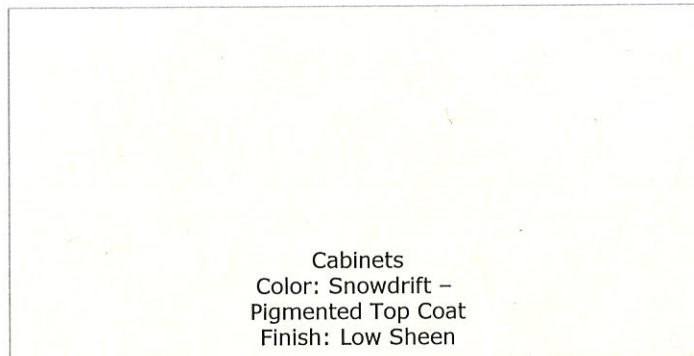

Cabinets
Color: Snowdrift –
Pigmented Top Coat
Finish: Low Sheen



Floor
Tile Level 7
Mount Claire 12x24 – MC30 Ash

Tile Shade and Texture Spectrum

STS-Shade and Texture Spectrum

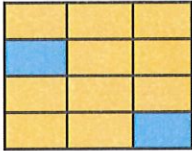

Light STS- The least amount of shade and texture variation attainable in naturally fired clay products.

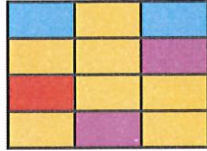

Moderate STS- Light to moderate shade and texture variation within each carton.



High STS- High shade and texture variation within each carton.

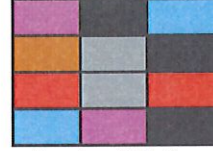

Random STS- Very high shade variation within each carton.

All tile varies some degree from piece to piece, shade to shade, and run to run. We suggest viewing several pieces from pieces from the current run whenever possible.

Tile Color: Elect Gray Variation: L M H R

Tile Color: Mount Claire Ash Variation: L M H R

Tile Color: Manor Predella Pebble Lumen White Variation: L M H R

Tile Color: Memor Petal Gray Variation: L M H R

Tile Color: Hawthorne Beveled Refined White Variation: L M H R

Tile Color: _____ Variation: L M H R

Tile Color: _____ Variation: L M H R

Tile Color: _____ Variation: L M H R

Tile Color: _____ Variation: L M H R

Tile Color: _____ Variation: L M H R

Homebuyer Signature: _____ Date: _____

Design Consultant: _____ Date: _____

BE INFORMED – Ceramic and Porcelain Tiles

REV 10.26.2018

Tile is an exceptionally durable floor and wall covering. Tile is a kiln-fired product. As with all fired products, there will be some variation in size and shade. This is an inherent quality of tile and results in varying color and sizing from tile to tile.

Small grout lines show irregularities in tile size. Wisenbaker will only install a 3/16" grout joint width on ceramic and porcelain tiles. _____

Grout can stain. Advanced Performance Grout promotes stain resistance, but can still stain if not properly cared for. _____

Electrical outlets and windows located on the backsplash will interrupt patterns, accents, and grout lines in backsplash tile patterns. The same can be expected on bath wall surrounds. Plumbing fixtures, towel bars and soap dishes can interrupt patterns, accents and grout lines. _____

If different tiles are used (for examples, stone and granite, or granite and tile) in a backsplash pattern, it will cause "lippings" (one tile sticking out further than the other) due to the different thickness of each material type. _____

Floor tile and mosaic tiles do not come with border trim pieces. If you choose a floor tile or mosaic tile for your backsplash be aware that you will have exposed edges on the perimeter. _____

Please be aware that due to warping in the tile, caused by the manufacturing process, certain patterns will show warping inconsistencies more than others. A "broken joint pattern", also known as a "subway", "staggered" or "offset" pattern will show warping and "lippings" at the grout joint that can be seen and felt. This is not a sign of a poor installation or manufacturing defect, rather certain pattern layouts will make this natural variation more noticeable. Wisenbaker adheres to the guidelines set forth by Tile Council of North America and ANSI standards regarding acceptable tile lippage and warpage. _____

Tiles are not guaranteed against dye lot variations, texture differences, or lack of uniformity in color. Similarly, grout colors are also subject to variations. Often tiles will not have trim available; if it is available, and if it is offered, observable variations between a wall tile and its trim pieces are normal. _____

The industry has established realistic guidelines for tolerance levels. Please understand that the samples from which you are selecting are representative of, but not necessarily exactly what will be installed in your home. _____

The perception of color, texture, patterns, etc., in a smaller sample may be different when the entire application is grouted and completed. For example, the color may be more or less intense, the texture more or less pronounced, and the shading more or less obvious. Manufactures discontinue colors and patterns from time to time. If this occurs, you will be notified that a reselection is required. _____

Mesh Mounted Mosaic or Listel's

As a rule, mesh mounted tile mosaics (whether assembled on sheets or listels) will have noticeable differences in the thickness of the finished grout joints. This is due to the fact that the tile edges are not mechanically finished, which means they will produce more natural variations in grout joint spacing. In addition, all tile has a certain amount of surface or thickness variation from piece to piece as part of the firing process. This can and will create the look of an uneven or crooked installation. Please be aware that these variations should not be viewed as a product defect or the result of an installation error. Please be aware that the overall look of a mesh mounted tile mosaic install will be altered by the addition of the grout required to complete the install. _____

Address and community where selections will be installed

Homebuyer Signature

Date

Design Consultant Signature

Date

Refer to www.Wisenbaker.com for additional information

Be Informed Know Your Natural Stone Tile

Natural stone flooring has been a favorite product of elegant homes for many years. This quarried product with its unique, natural veining and impurities, offers perhaps the most unique flooring available. Many of its characteristics are listed below.

Your stone floor will vary in color and shade from the sample you selected. _____

Stone is a product of nature. Minerals and impurities become part of the stone. This is not a defect in your stone. For this reason there will be variations in the color, shade and finished look of each tile in a natural stone floor. _____

Grout can stain. Advanced Performance Grout promotes stain resistance, but can still stain if not properly cared for. _____

Stone is a porous material and for that reason the finish cannot be guaranteed. _____

Veining will occur. Veins tend to be natural weak areas in the stone and may crack. _____

Finish, shine and shading may vary from one piece to another. _____

Stone is very porous and it will stain, scratch and etch. _____

We do not seal the stone. If you elect to do so, please know that sealing the stone will change the color and appearance of it. _____

Part of the natural beauty of tumbled stone is that it has been broken by a tumbling process. You will have irregular edges, holes and veining, the majority of which will be filled with grout during the grouting process. _____

The industry has developed realistic guidelines for tolerance levels. Please understand that the samples from which you are selecting are representative of, but not necessarily exactly, what will be installed in your home. _____

The perception of color, texture, patterns, etc. in a smaller sample may be different when the entire application is grouted and completed. For example, the color may be more or less intense, the texture more or less pronounced and the shading more or less obvious. Manufacturers discontinue colors from time to time. If this occurs, you will be notified that a reselection is required. _____

Mesh Mounted Mosaic or Listels

As a rule, mesh mounted natural stone tile mosaics (whether assembled on sheets or listels) will have noticeable differences in the thickness of the finished grout joints. This is due to the fact that the tile edges are not mechanically finished, which means they will produce more natural variations in grout joint spacing. This can and will create the look of an uneven or crooked installation. Please be aware that these variations should not be viewed as a product defect or the result of an installation error. Please be aware that the overall look of a mesh mounted tile mosaic install will be altered by the addition of the grout required to complete the install. _____

Address and community where selections will be installed

Homebuyer Signature

Date

Design Consultant Signature

Date

Refer to www.Wisenbaker.com for additional information

Be Informed Know Your Engineered Wood Floor

In recent years wood flooring, of many different species, has become a favorite. The natural beauty and unique graining of each wood floor makes it a little different and personal. The factory-controlled finish is contamination free and superior to job site application in regards to speed of installation and application of stain and wear layers.

_____ Wood is a natural product and will have variations in color, tone and grain.

_____ Wood floors will scratch and indent. If you have large pets you may want to carefully consider the use of hard wood floors.

_____ Natural color change will occur during the aging process of your wood floor. This is called patina.

_____ High heels will cause indentations on your floor. A 100-pound woman in high heels exerts 1,000 pounds of pressure.

_____ Use **Bona Hardwood Floor Cleaner** regularly to clean your floors. **DO NOT use Murphy's Oil Soap**, polishes, waxes, or any cleaning products without referring to www.Wisenbaker.com for links to manufacturer's maintenance guidelines. **Water and wood floors do not mix. Do not wet mop, damp mop, or steam mop, your wood floors.**

_____ Hand-scraped wood will look different installed on your floor than installed in the showroom or as a sample. Lighting can affect the overall appearance of the flooring and with darker woods this will be more noticeable. Influencers such as lighting, grain and scraping patterns and finish gloss level may cause the floor to look shiny or glossy in one spot and matte or satin in another. Some boards will be rougher and some smoother. The scraping will be more pronounced and/or deeper in some areas than others. This is natural in a hand-scraped floor, is desirable and is not a defect.

_____ Engineered wood floors are not sanded on the job site. They are pre-finished, therefore "over boarding" may take place (one plank being slightly higher than another). This is mainly prevalent in square edge products.

_____ Due to species and staining limitations, stair railings, newel posts, shoe molding, transitions and stair nosing will not match your hardwood floors manufactured finish in exact color or sheen. Please consider this prior to choosing wood for your stairs.

_____ When transitioning from wood flooring to a different hard surface, like tile or vinyl plank, you will find a threshold transition. This piece of wood transition will be stained to coordinate with the wood floor. The purpose of the transition is to bridge the height difference between the wood and the adjoining surface. Please be aware that the transition will be seen and will not be flush to either flooring surface.

_____ It's recommended that you maintain the relative humidity inside your home between 40% and 50% with an indoor temperature range of 60 to 80 degrees Fahrenheit. The maximum range for relative humidity is 35% to 55%. Failure to do so could result in damage such as cupping, bowing, splintering, etc.

_____ The industry has established realistic guidelines for tolerance levels. Please understand that the samples from which you are selecting are representative of, but not necessarily exactly what will be installed in your home. The perception of color, texture, patterns, etc. in a smaller sample may be different when the entire application is completed. For example, the color may be more or less intense, the texture more or less pronounced, and the shading more or less obvious. Manufacturers discontinue colors and patterns from time to time. If this occurs, you will be notified that a reselection is required.

Address and community where selections will be installed

Homebuyer Signature

Date

Design Consultant Signature

Date

Be Informed Know Your Carpet

Carpet is one of the most widely used floor coverings in the country, and for good reason. It is beautiful, durable, and available in many different textures, types, and colors. As with all floor coverings, there are characteristics of carpet that you need to know. While most Wisenbaker carpets have stain protectors, no carpet is stain proof.

_____ Seams will be visible. Seams will be more visible in a lighter colored carpet than in a darker one.
_____ Seams will be more visible in shorter pile heights than in longer pile heights.

_____ All carpet shows tracks. We offer some textured carpets that track "less", but not "track proof".

_____ Colors and shades do vary from one dye lot to another.

_____ Some carpet styles will shed after installation for a period of time. This "fuzz" is normal.

_____ Use an upright vacuum cleaner for routine cleaning. (at least twice a week under normal use).

_____ Hot water extraction (steam cleaning) is the industry preferred method of professional cleaning.
_____ Insist on truck mounted equipment.

_____ Application of **stain resist chemical** offered by in home cleaning companies WILL void any stain resist warranties.

_____ The industry has established realistic guidelines for tolerance levels. Please understand that the samples from which you are selecting are representative of, but not necessarily exactly what will be installed in your home.

_____ Please be aware that when seaming two different types of carpets together seams will be accentuated due to the seaming together of two types of colors, patterns and pile heights.

_____ The perception of color, texture, patterns etc. in a smaller sample may be different when the entire application is completed. For example, the color may be more or less intense, the texture more or less pronounced, and shading more or less obvious. Manufacturers discontinue colors and patterns from time to time. If this occurs, you will be notified that a reselection is required.

Refer to www.Wisenbaker.com for additional information.

Address and community where selections will be installed

Homebuyer Signature

Date

Design Consultant Signature

Date



Granite/Marble Information Sheet

Congratulations on choosing natural granite/marble for your new countertops. Before you finalize your decision, please read this document to become more familiar with the natural characteristics of this product.

*Due to the fact that granite is a product of nature, the characteristics of a particular sample will not be uniformly present in other samples of the same color. A sample serves only to indicate, in a general way, the color markings, and texture usually found in a block of granite/marble.

*Because of the inherent characteristics, no two pieces of granite/marble, such as sections of a kitchen countertop, will be identical. The countertops or areas of the countertops will not be replaced due to color and/or texture variation within or between the pieces of your installation. If granite tile is used on the backsplash, it will not match the slab countertops.

*Because granite/marble is natural and is quarried from the ground, it contains inherent characteristics:

-Hairline cracks (caused during the quarrying process and are visible)

-Fissures (a natural clef in the formation which are mistaken for a crack)

-Pits (small crystals that loosen and may fall out during polishing leaving small voids in the surface)

-Inclusions (areas of stone which do not look like the rest of the stone and may vary in small to countertop size)

-Some colors may have a "grain" or pattern direction. The Fabricator will attempt to maintain that grain or pattern direction throughout a given countertop, but may be unable to.

*Any movement of cabinets, walls, or general settling of your home could cause any of these to open and/or become very noticeable. The Marble Institute of America deems it appropriate to repair any surface blemishes or cracks during the fabrication and installation process.

*Granite/marble is quarried from the ground. It is impossible to do seamless or seemingly seamless installations of countertops. Granite/marble countertops can be seen and felt. Granite/marble slabs are not always perfectly flat causing some seams to be uneven from front to back. Granite/marble slabs frequently vary thickness from one end to another +/- 1/8", so the total potential variance in thickness between slabs could be as much as 1/4". When this occurs, the thicker slab will be feathered to match the thinner slab at the edge seam location.

*Since it is quarried material, slab sizes are random. The maximum guaranteed size of a countertop will be 100"x54". Occasional random counters may exceed this dimension by a few inches, but the

increased size is not guaranteed from house to house. When necessary, seams may be included in the sink or cook tops cutouts.

*Being very porous, granite/marble may absorb many types of liquids and will be prone to staining. To help resist stains, granite/marble must be sealed with a penetrating sealer. A sealer should be reapplied every 12 months to maintain its repellent characteristics. No sealer is a guarantee against stains and sealers do not repel oils. Food oils, present in most foods, must be cleaned promptly to prevent staining.

*The polish of granite is very durable; however, it can be scratched with other household items. The finish may be dulled with the application of unapproved cleaning agents. It is not recommended to use abrasive cleaners on granite surfaces and avoid spray cleaners.

*To clean granite it's best to use warm soapy water and a soft cloth or Simple Green for more difficult spots.

*Granite/marble slabs are not sealed from the factory or at the time of installation but is recommended to seal it once a year with a granite/marble or Natural Stone sealer by the homeowner or a professional.

*Any overhang over more than 12" will need some type of support in place provided by the builder.

*Most all seams will be in the center of the cooktops on long cooktop runs and in the center of the kitchen sink on Islands

*Granite/marble is not heat proof. *It is recommended to use a trivet or hot pads*, especially when using cooking units such as electric frying pans, slow-cookers, or roaster ovens. Do not place hot pots, pans or dishes directly onto the surfaces.

Homebuyer Signature

Date

Builder Representative

Date



Darling Homes Countertop Information, Care and Maintenance Sheet

Quartz and Cambria quartz

- *Quartz is a non-porous, homogeneous and highly durable and resistant to scratching, but not scratch proof, staining and water absorption and is virtually maintenance free.
- *It is composed of 93% Natural Quartz and 7% high quality polyester resin.
- *Quartz surfaces are relatively hard to scratch, but they still can occur. Avoid using stone or harder materials directly on your countertops. *Certain stoneware dishes (like pizza stones) containing rough silica can scratch your countertops as you turn them or drag them on the top.*
- *Clean with warm soapy water and a soft cloth or Simple Green for stubborn spots and a light nylon brush can be used to agitate the area. Do not use strong abrasive and/or alkaline cleaning products.
- *Quartz is not heat proof. *It is recommended to use a trivet or hot pads*, especially when using cooking units such as electric frying pans, slow-cookers, or roaster ovens. Do not place hot pots, pans or dishes directly onto the surfaces.
- *Quartz does not need to be sealed.
- *All Edges are available, except Chiseled.
- *Any overhang over more than 12" will need some type of support from the builder.
- *Most all seams will be in the center of the cooktops on long cooktop runs and in the center of the kitchen sink on Islands.
- *Cambria Quartz will not book match perfect on seams with certain colors due to no two slabs match exactly. We do our best to match them with the movement of available slabs.
- *Cambria Quartz Costal series are smaller sized slabs at 120"x55" and are available in these color: Beaumont, Seagrove, Kelvin Grove, Summerhill.

Mountain Top Stone

- *Mountain Top Stone is an Engineered Marble and not as durable as quartz.
- *Mountain Top Stone *cannot* be used in kitchens.
- *For cleaning it's best to use warm soapy water with a soft cloth or Simple green for more difficult spots.
- *Any cabinet over 94" long will have a seam in the center of the top.
- *The only edge offered is a square edge.
- *Mountain top is not heat proof. *It is recommended to use a trivet or hot pads*, especially when using cooking units such as electric frying pans, slow-cookers, or roaster ovens. Do not place hot pots, pans or dishes directly onto the surfaces.
- *Mountain Top Stone thickness is 1.2 cm (5/8").

Neolith

*Neolith is a Sintered Stone Surface made up of Granite, Quartz, Glass Minerals and Silica.

*Neolith has the following qualities.

- Resistant to high temperatures
- Scratch resistant not scratch proof
- Easy to clean
- Greenguard certified
- Hygienic (suitable for contact with food)
- Waterproof and liquid-resistant with an absorption level near zero (0.08)

*There will be a seam at all ninety-degree corners (L shaped cabinets) and if the run of cabinets is longer than 126" there will be a seam directly under one edge of the cooktop (see drawing).

*Neolith can only be used on straight runs of cabinets and the cabinets cannot have cookout bump-outs due to the resulting ninety-degree angle.

*Neolith can only be used on islands 4' x 10' or smaller.

*All sink cut outs will have a small radius in each corner and the exposed edge cut out will show the body color of the slab.

*Any overhang will need to have some type of support provided by the builder.

*Neolith thickness is 12mm (1/2").

*The only available edge for Neolith is 1 1/2" miter.

Homebuyer Signature

Date

Builder Representative

Date

Darling Homes Counter Top Edges

Standard Edges



Square Edge

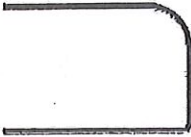

Waterfall Edge

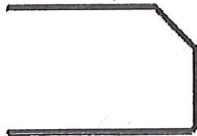

Bevel Edge

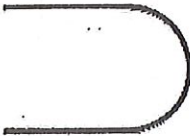

Bullnose Edge

Mountain Top Stone

Square Edge Only

Neolith Edge

Mitered Edge Only