

ALDERNEY FARMHOUSE

BELLVILLE, TEXAS



GENERAL NOTES:

THIS DESIGN COMPLIES WITH 2012 INTERNATIONAL RESIDENTIAL CODE, PUBLISHED BY THE INTERNATIONAL CODE COUNCIL. PERCH PLANS, LLC DOES NOT ASSUME ANY RESPONSIBILITY FOR ADHERING TO LOCAL AND STATE CODES. IT IS USER'S SOLE RESPONSIBILITY TO DETERMINE THE NECESSARY LOCAL AND STATE CODES WHICH THE DESIGNS MAY NEED IN ORDER TO BE IN COMPLIANCE. YOU UNDERSTAND THAT WE DO NOT PROVIDE ANY SERVICES IN RELATION TO THE DESIGNS AVAILABLE FOR PURCHASE ON OUR SITE, INCLUDING BUT NOT LIMITED TO BUILDING SERVICES OR OTHER PROFESSIONAL SERVICES SUCH AS GEOTECHNICAL ENGINEER'S SOILS REPORT, STRUCTURAL ENGINEER FOR FOUNDATION AND FRAMING DESIGN. WE STRONGLY ENCOURAGE YOU TO WORK WITH PROFESSIONALS IN THE IMPLEMENTATION OF OUR DESIGNS.

ANY CHANGES TO THE DESIGNS AS PURCHASED ARE DONE AT YOUR OWN RISK. WE WILL ENTERTAIN REQUESTS FOR MODIFICATIONS AND MAY ACCEPT OR DENY THE SERVICE REQUEST AT OUR SOLE DISCRETION.

YOU ARE SOLELY RESPONSIBLE FOR PROVIDING, AT YOUR OWN EXPENSE, ALL EQUIPMENT NECESSARY TO USE THE SERVICES.

DRAWING SHEET INDEX:

COVER PAGE	A - 0.1
SITE PLAN	A - 1.1
ROOF PLAN	A - 1.2
FLOOR PLANS	A - 2.1
REFLECTED CEILING PLANS	A - 2.2
EXTERIOR ELEVATIONS - FRONT / RIGHT	A - 3.1
EXTERIOR ELEVATIONS - REAR / LEFT	A - 3.2
INTERIOR ELEVATIONS	A - 4.1
INTERIOR ELEVATIONS	A - 4.2
INTERIOR ELEVATIONS	A - 4.3
DETAILS	A - 5.1
DETAILS	A - 5.2
DETAILS	A - 5.3
MEP PLANS	MEP - 1

AREA CALCULATIONS:

CONDITIONED AREA-	
FIRST FLOOR	1384 SF
SECOND FLOOR	922 SF
	2306 SF
UNCONDITIONED AREA-	
COVERED PORCHES	258 SF
TOTAL	2564 SF

PERCH PLANS

© All Rights Reserved. These drawings are the property of Perch Plans, LLC. No part of these drawings may be reproduced or transmitted in any form or by any means, electronic or mechanical, including photocopying, recording, or by any information storage and retrieval system, without the prior written permission of Perch Plans, LLC.

NAME ALDERNEY FARMHOUSE
 ADDRESS LOT 1 HOLLAND ST.
 CITY BELLVILLE, ST TX Zip 77418
 PERCH PLANS, LLC 100 BRAZOS ST
 AUSTIN, TX 78701
 P-844-817-1999

DATE 20 JUL. 2017
 JOB #

A-0.1
1 of 14

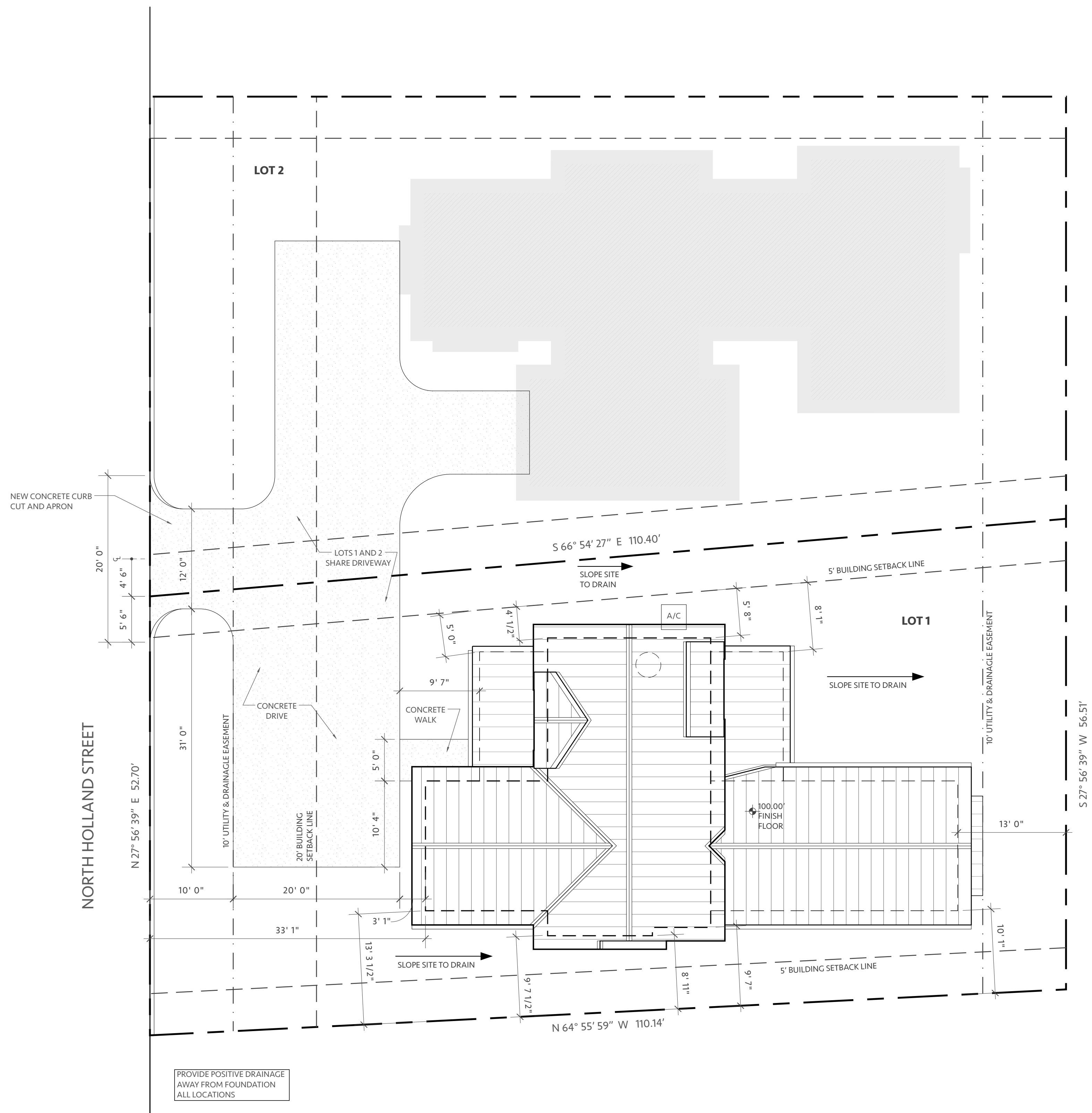

SITE PLAN
SCALE: 1/8" = 1'-0"



SITE INFORMATION:	
AREA CALCULATIONS:	
CONDITIONED SPACE	2306 SF
COVERED PORCHES	258 SF
TOTAL	2564 SF

- GENERAL SITE PLAN NOTES:**
1. REPORT ANY AND ALL ERRORS, DISCREPANCIES, OR OMISSIONS TO THE ARCHITECT PRIOR TO THE ORDERING OF ANY MATERIALS AND/OR THE COMMENCEMENT OF ANY WORK.
 2. VERIFY LOCATION OF HOUSE AND DRIVEWAY LAYOUT WITH OWNER AND ARCHITECT.
 3. FINAL GRADING TO PROVIDE FOR POSITIVE DRAINAGE FROM THE FOUNDATION.
 4. SITE INFORMATION IS BASED ON A PROFESSIONAL SURVEY PROVIDED BY THE OWNER.

CODE COMPLIANCE:	
BUILDING CODE	IRC 2012 (W/ LOCAL AMENDMENTS SEC. 25-12-1)
ENERGY CODE	IECC 2012 (W/ LOCAL AMENDMENTS SEC. 25-12-263)
ELECTRICAL CODE	NEC 2011 (W/ LOCAL AMENDMENTS SEC. 25-12-114)
MECHANICAL CODE	UMC 2012 (W/ LOCAL AMENDMENTS SEC. 25-12-133)
PLUMBING CODE	UPC 2012 (W/ LOCAL AMENDMENTS SEC. 25-12-153)
FIRE CODE	IFC 2012
ACCESSIBILITY CODE	TAS 2012 (W/ LOCAL ORD. NO. 20140130-021, SEC. R320)

NAME: ALDERNEY FARMHOUSE
ADDRESS: LOT 1 HOLLAND ST.
CITY: BELLVILLE, ST. TX ZIP: 77418
PERCH PLANS, LLC
100 BRAZOS ST.
AUSTIN, TX 78701
H-844-817-1999

PERCH
PLANS

REGISTERED ARCHITECT
MORTY A. BROWN
2015
STATE OF TEXAS

DATE: 20 JUL. 2017
JOB #: A-1.1
2 of 14

© All Rights Reserved. These drawings shall be used only for the project, site, location, and time for which they were prepared and may vary by any method, for any purpose without previous written permission from PERCH PLANS.

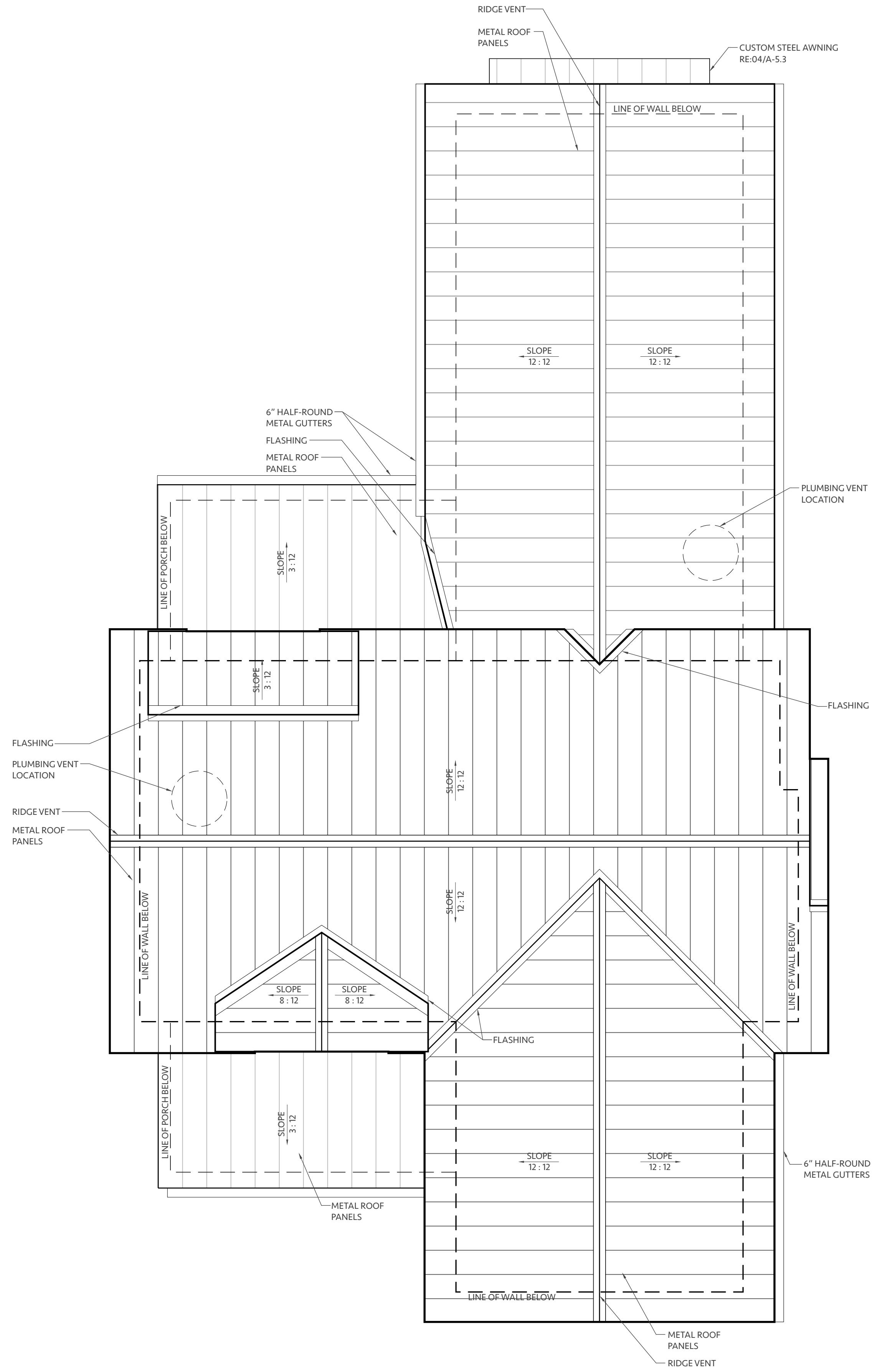

01

ROOF PLAN

SCALE: 1/4" = 1'-0"



DATE 20 JUL. 2017

JOB #

A-1.2

3 of 14



NAME ALDERNEY FARMHOUSE

ADDRESS LOT 1 HOLLAND ST.

CITY BELLEVILLE, ST. TX, ZIP 77418

PERCH PLANS, LLC 100 BRAZOS ST. AUSTIN, TX 78701
 P: 844-817-1999

PERCH
PLANS

© All Rights Reserved. These drawings shall be used only for the project and site for which they were prepared. No part of these drawings may be reproduced or transmitted in any form or by any means, electronic, mechanical, photocopying, recording, or by any information storage and retrieval system, without prior written permission from PERCH PLANS.

AREA CALCULATIONS:	
CONDITIONED AREA-	
FIRST FLOOR	1384 SF
SECOND FLOOR	922 SF
	2306 SF
UNCONDITIONED AREA-	
COVERED PORCHES	258 SF
TOTAL	2564 SF

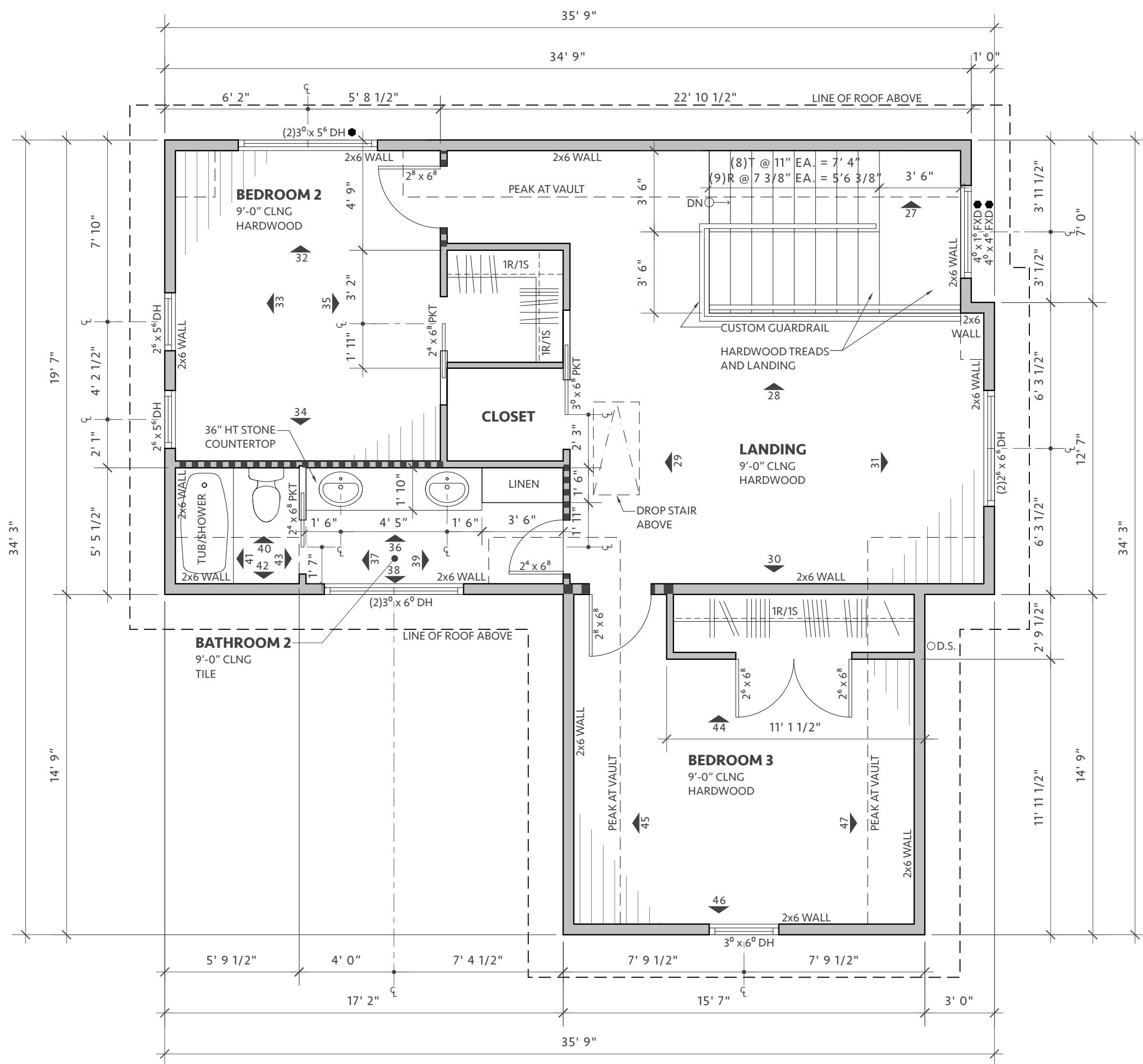

02 SECOND FLOOR PLAN
SCALE: 1/4" = 1'-0"

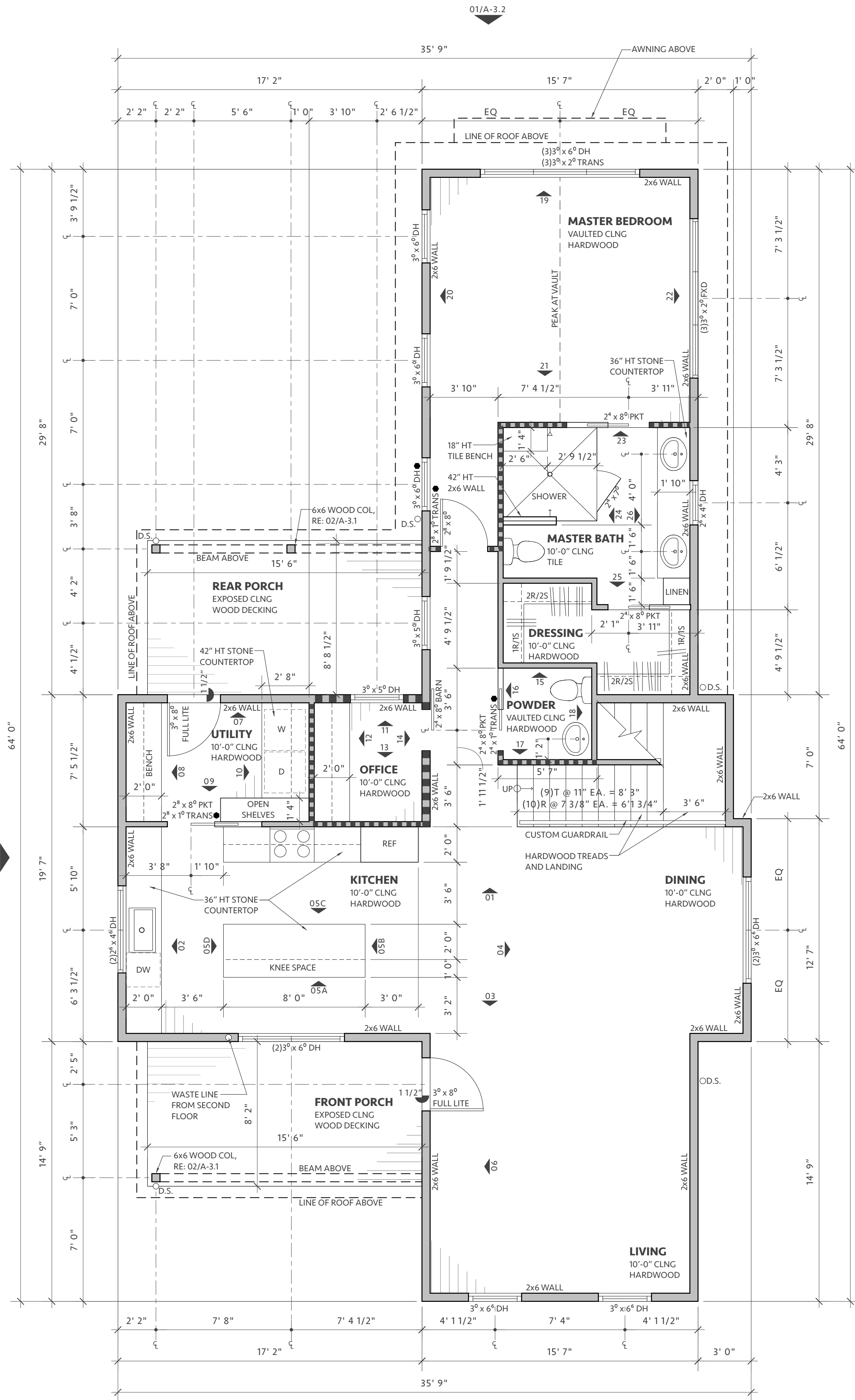

01 FIRST FLOOR PLAN
SCALE: 1/4" = 1'-0"

- GENERAL FLOOR PLAN NOTES:**
- ALL CONSTRUCTION TO CONFORM TO ALL APPLICABLE LOCAL, STATE, AND NATIONAL BUILDING CODES.
 - REPORT ANY AND ALL DISCREPANCIES, ERRORS, AND/OR OMISSIONS IN THESE DOCUMENTS TO THE ARCHITECT PRIOR TO THE ORDERING OF ANY MATERIALS AND/OR THE COMMENCEMENT OF CONSTRUCTION.
 - ALL DIMENSIONS TO BE VERIFIED AT THE JOB SITE. UNDER NO CIRCUMSTANCE SHALL ANY DIMENSION BE SCALED FROM THESE DRAWINGS. ANY CRITICAL DIMENSIONS NOT GIVEN SHALL BE BROUGHT TO THE ATTENTION OF THE ARCHITECT PRIOR TO CONSTRUCTION.
 - WINDOW HEADS ARE 8'-0" A.F.F. FIRST FLOOR AND SECOND FLOOR UNLESS NOTED OTHERWISE.
 - DOOR AND WINDOW ROUGH OPENINGS SHALL BE SUCH THAT THE OUTSIDE EDGES OF ADJACENT DOOR AND WINDOW TRIM IS ALIGNED, UNLESS OTHERWISE NOTED.
 - WINDOW UNIT SIZES ARE APPROXIMATE UNIT SIZES. VERIFY ACTUAL SIZES AND ROUGH OPENINGS REQUIREMENTS WITH MANUFACTURER.
 - DOOR AND WINDOW HEADS, JAMBS & SILLS TO ALIGN WITH ADJACENT UNITS UNLESS NOTED OTHERWISE.
 - REVIEW MEP AND RCP PLANS PRIOR TO FRAMING TO ALLOW FOR PROPER CENTERING OF RECESSED LIGHT FIXTURES, VENTS, ETC.

WALL LEGEND

FRAME WALL:	FULL HEIGHT:	
	HALF WALL:	
	SOUND INS:	
	STONE:	

SYMBOL LEGEND

TEMPERED GLASS:	
-----------------	--

PERCH PLANS

NAME: ALDERNEY FARMHOUSE
 ADDRESS: LOT 1 HOLLAND ST.
 CITY: BELLVILLE, ST TX ZIP: 77418
 PERCH PLANS, LLC 100 BRAZOS ST
 AUSTIN, TX 78701
 H-844-817-1999

DATE: 20 JUL. 2017
 JOB #

A-2-1
 4 of 14

REGISTERED ARCHITECT
 MONTY A. BROWN
 2015
 STATE OF TEXAS

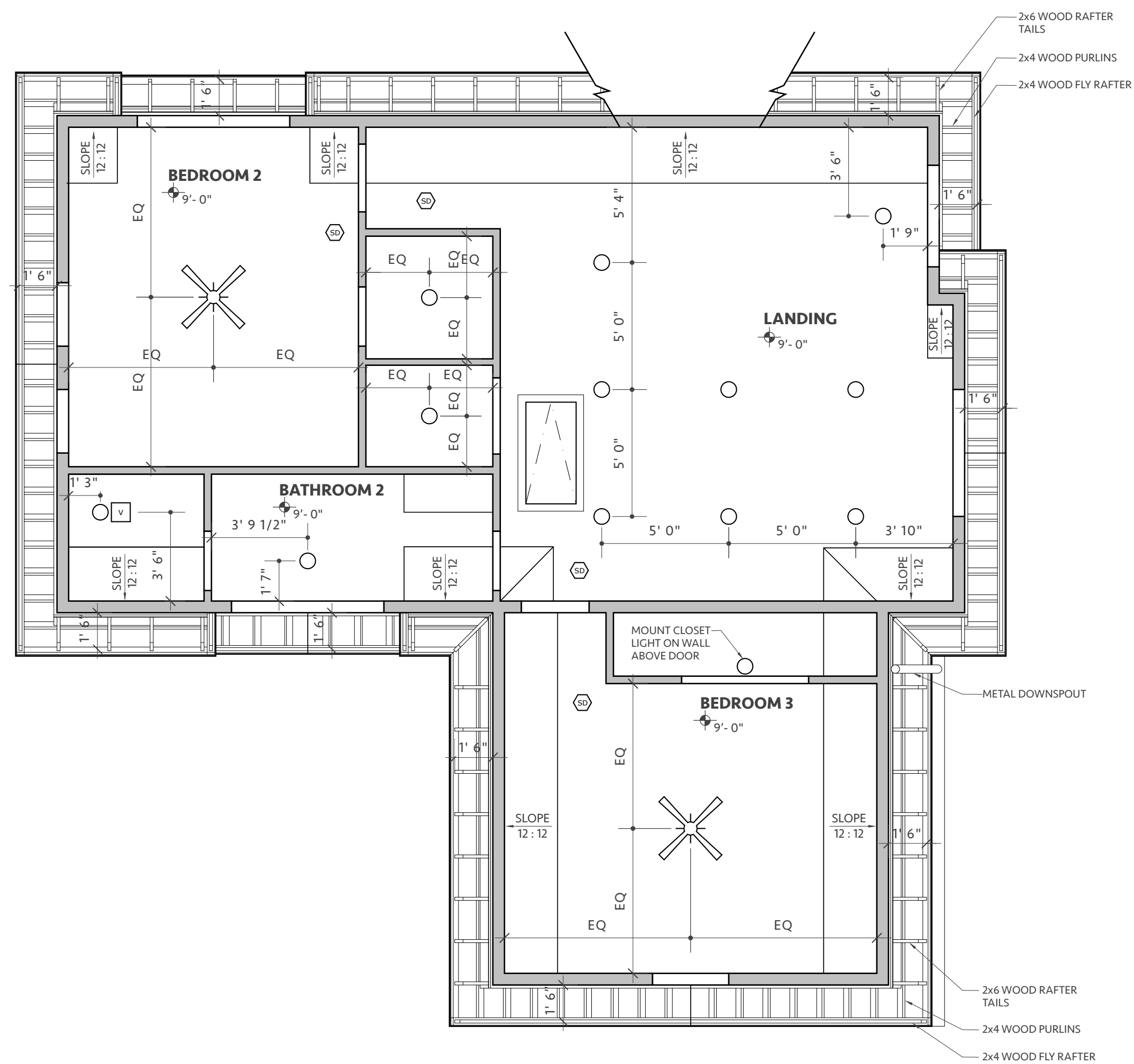

02 RCP - SECOND FLOOR
SCALE: 1/4" = 1'-0"

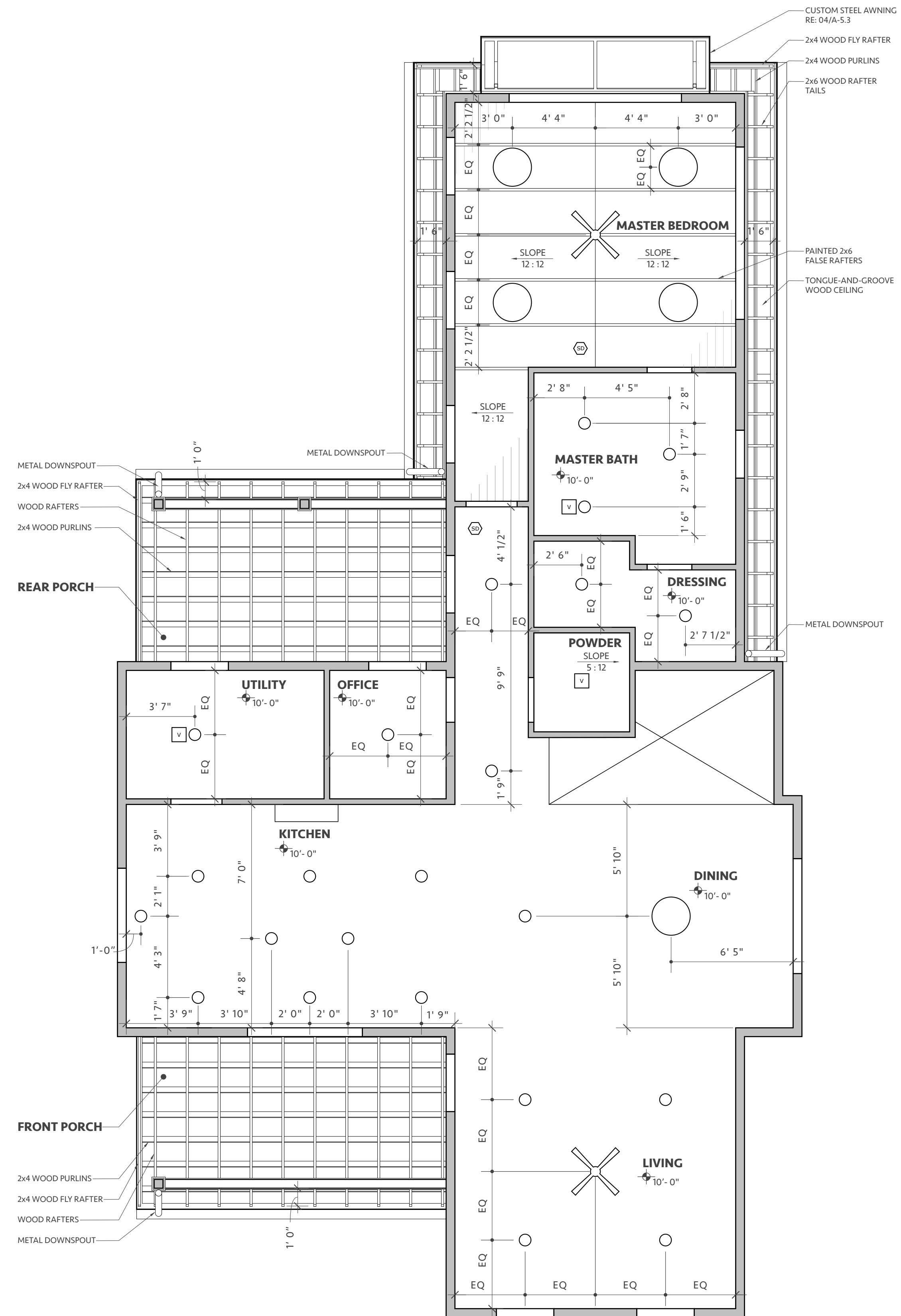

01 RCP - FIRST FLOOR
SCALE: 1/4" = 1'-0"

NAME ALDERNEY FARMHOUSE
 ADDRESS LOT 1 HOLLAND ST.
 CITY BELLVILLE, ST. TX ZIP 77418
 PERCH PLANS, LLC 100 BRAZOS ST.
 AUSTIN, TX 78701
 H-844-817-1999

DATE 20 JUL. 2017
 JOB # A-2-2
 5 of 14

REGISTERED ARCHITECT
 TONY A. BROWN
 2015
 STATE OF TEXAS

PERCH PLANS
© All Rights Reserved. These architectural plans are the sole property of the architect. No portion, reproduction, or reuse may be made without the written permission of the architect.

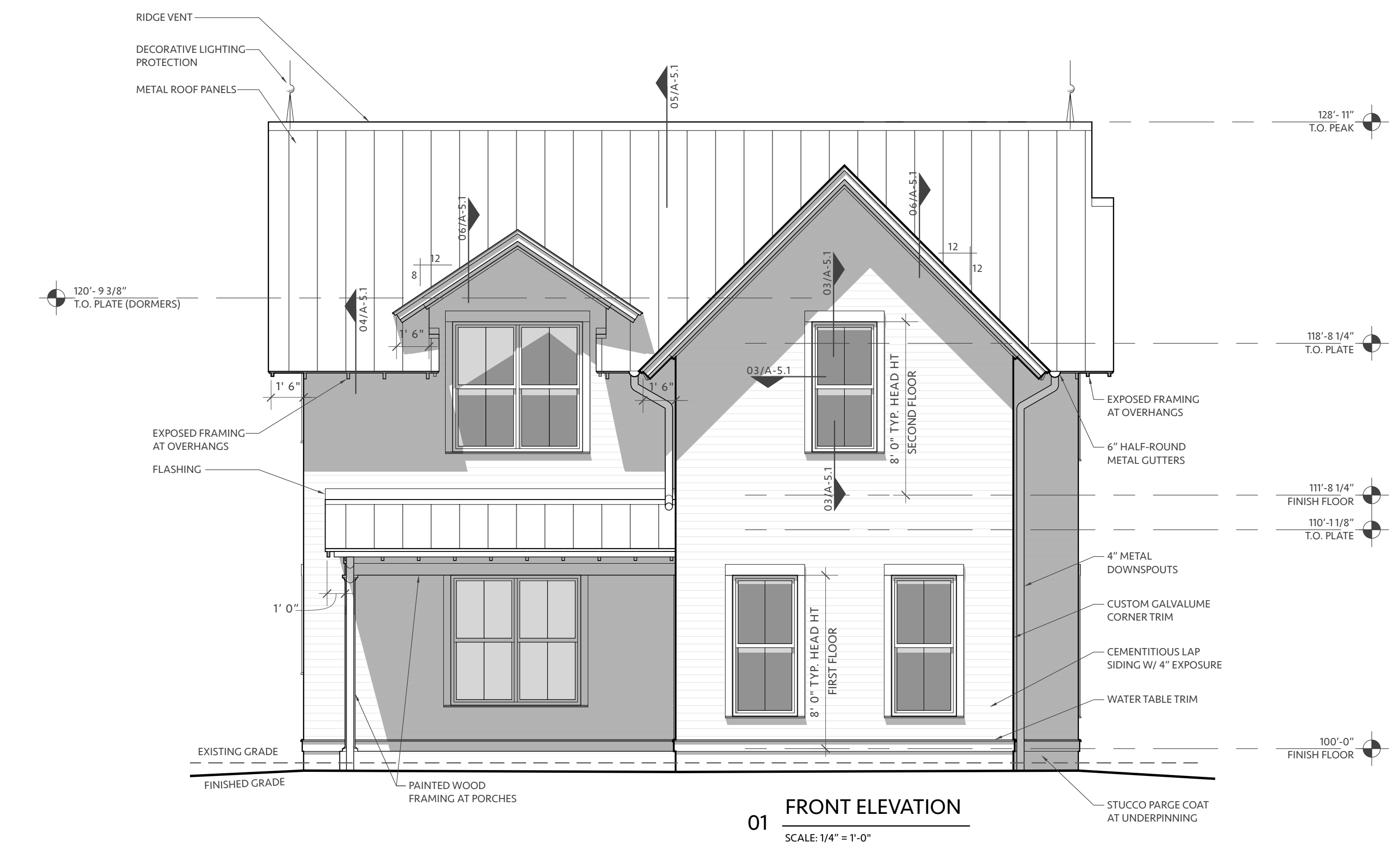

01 FRONT ELEVATION
SCALE: 1/4" = 1'-0"

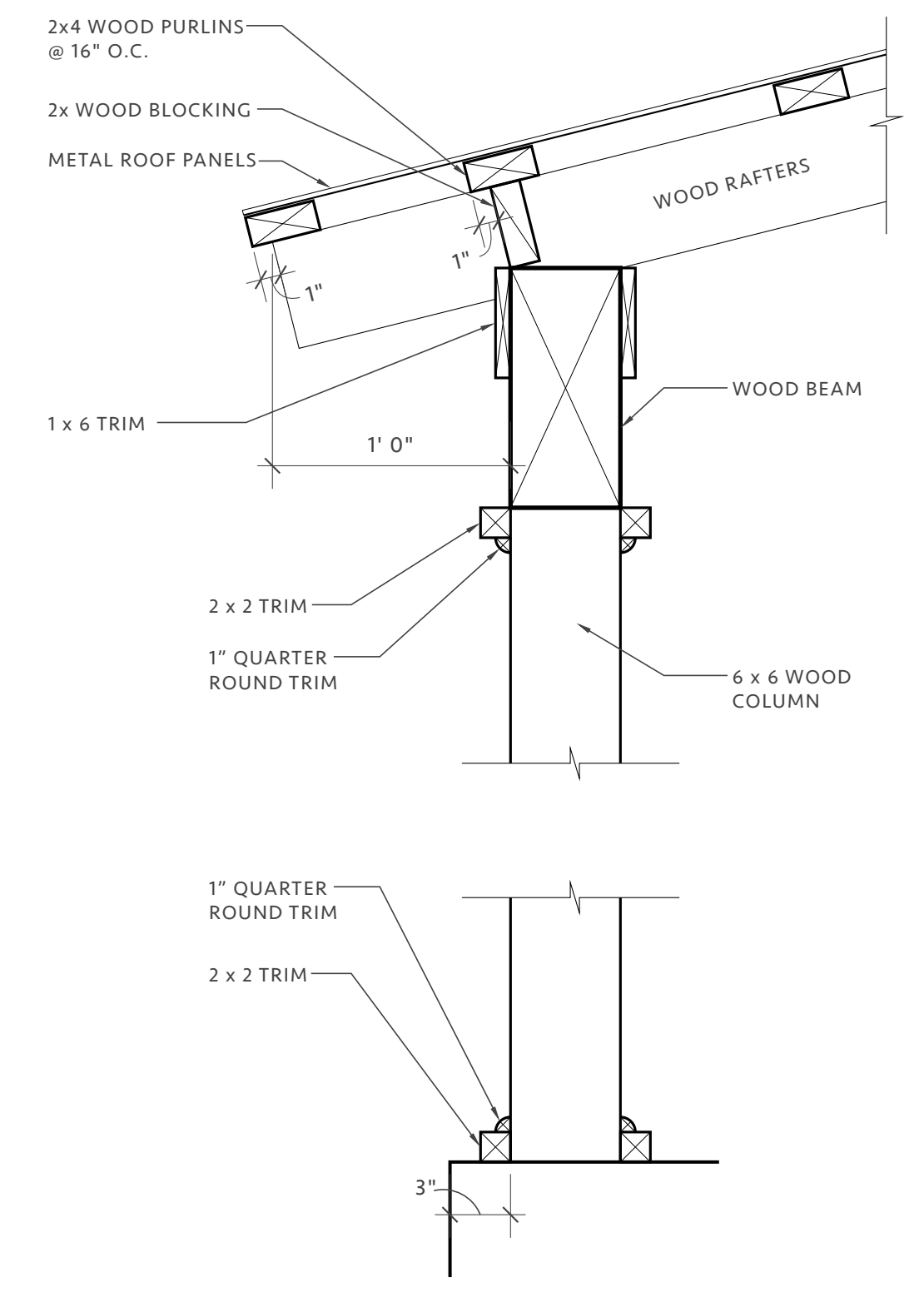

02 PORCH COLUMN
SCALE: 1 1/2" = 1'-0"

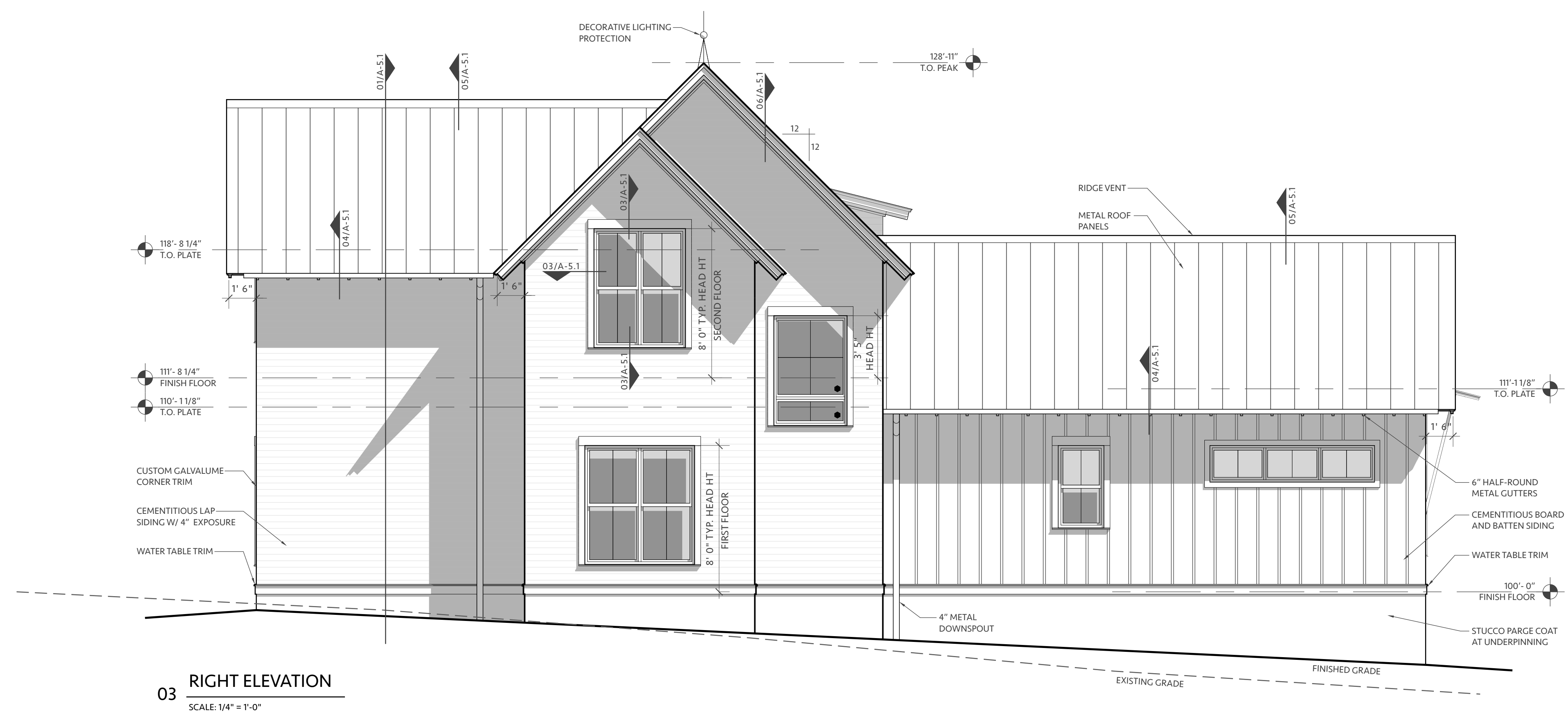

03 RIGHT ELEVATION
SCALE: 1/4" = 1'-0"

SYMBOL LEGEND	
●	TEMPERED GLASS

-PERCH PLANS

© All Rights Reserved. These architectural plans are the sole property of the architect. No portion hereof may be reproduced or transmitted in any form or by any method, electronic or mechanical, including photocopying, recording, or by any information storage and retrieval system, without the prior written permission of the architect.

NAME: ALDERNEY FARMHOUSE
 ADDRESS: LOT 1 HOLLAND ST.
 CITY: BELLVILLE, ST. TX ZIP: 77418
 PERCH PLANS, LLC 100 BRAZOS ST. AUSTIN, TX 78701
 P: 844-817-1999

DATE: 20 JUL. 2017
 JOB #: A-3.1
 6 of 14

A-3.1

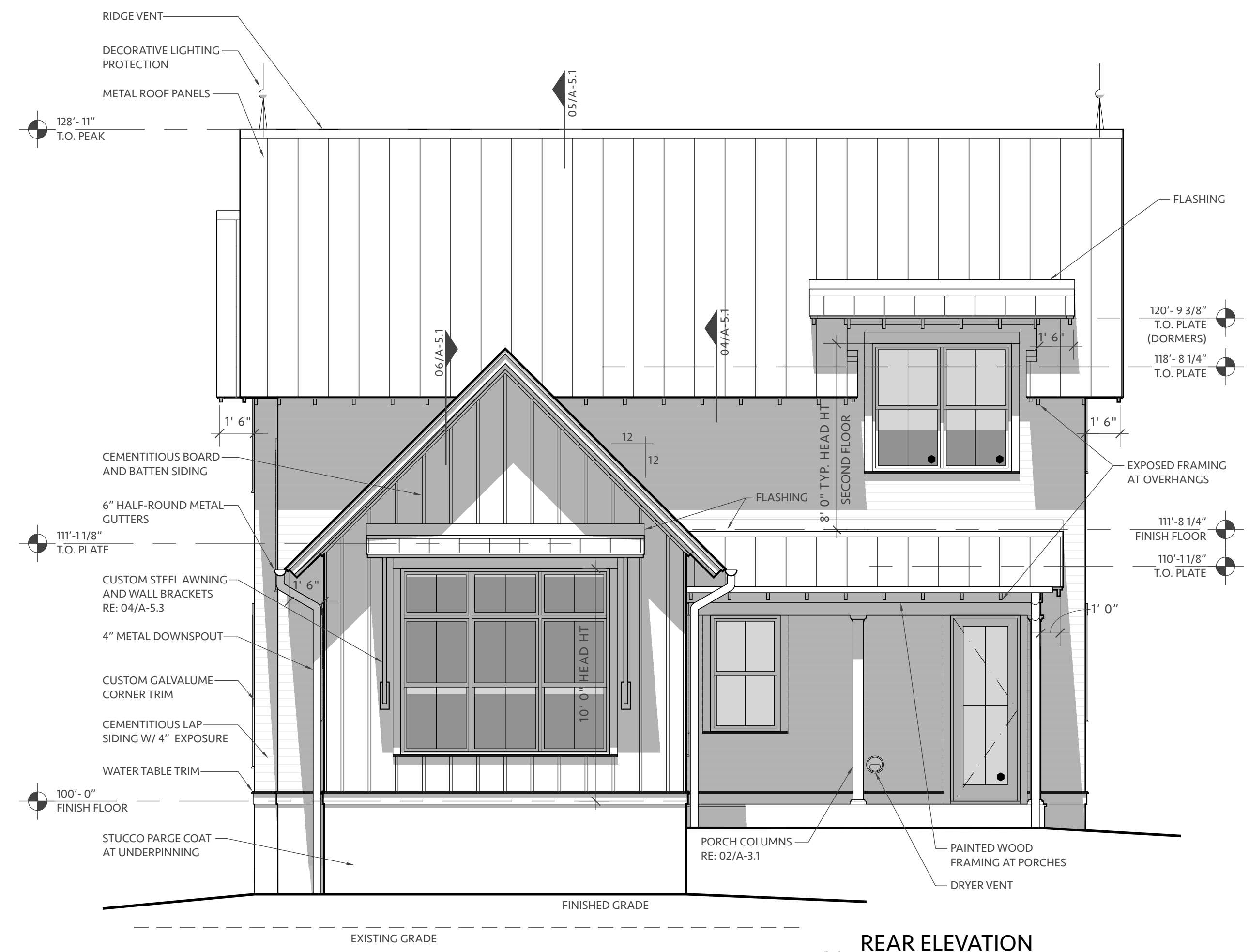

01 REAR ELEVATION
SCALE: 1/4" = 1'-0"



02 LEFT ELEVATION
SCALE: 1/4" = 1'-0"

SYMBOL LEGEND	
●	TEMPERED GLASS

PERCH PLANS

© All Rights Reserved. These architectural plans are the property of the architect. No portion of these plans may be reproduced or transmitted in any form, by any method, for any purpose without the prior written permission of the architect.

NAME: ALDERNEY FARMHOUSE
 ADDRESS: LOT 1 HOLLAND ST.
 CITY: BELLVILLE, ST. TX ZIP: 77418
 PERCH PLANS, LLC 100 BRAZOS ST. AUSTIN, TX 78701
 P: 844-817-1999

A-3-2

DATE: 20 JUL. 2017
 JOB #

7 of 14

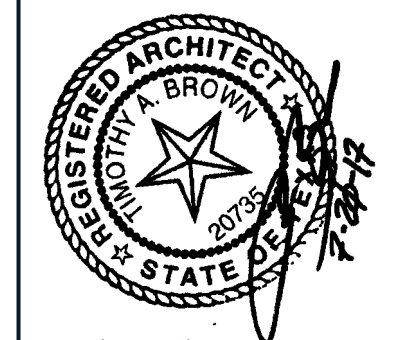

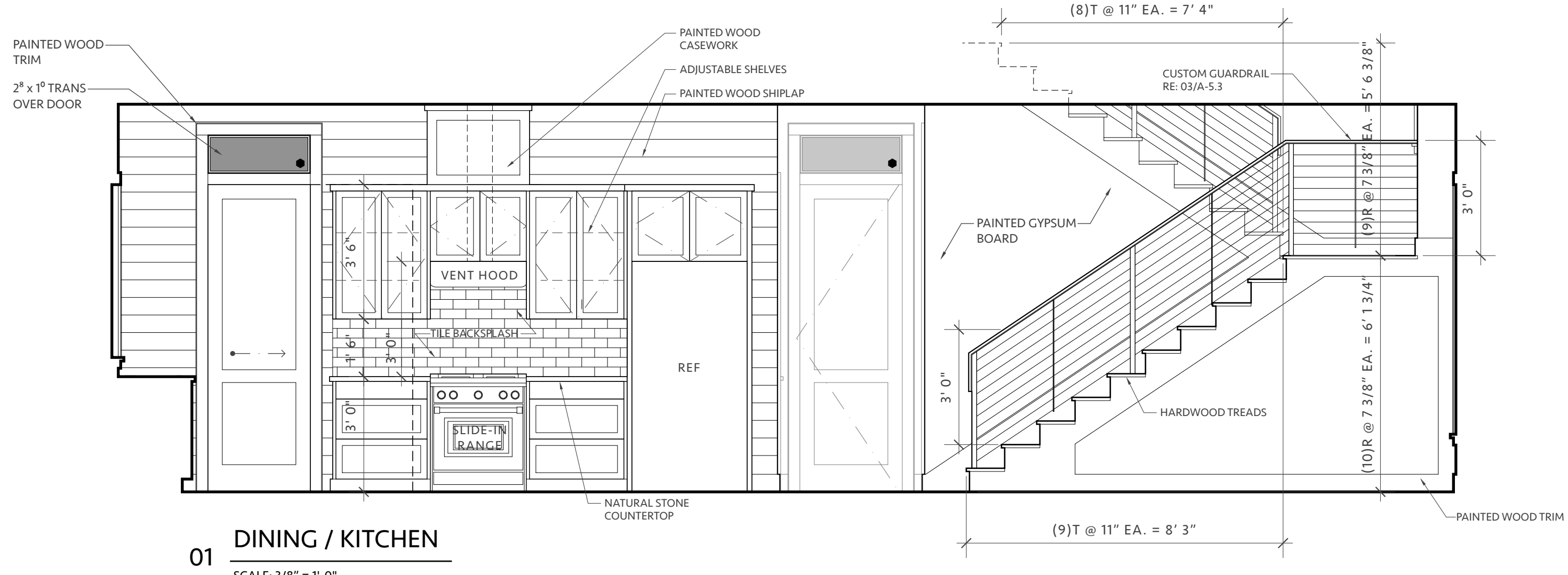

01 DINING / KITCHEN
SCALE: 3/8" = 1'-0"

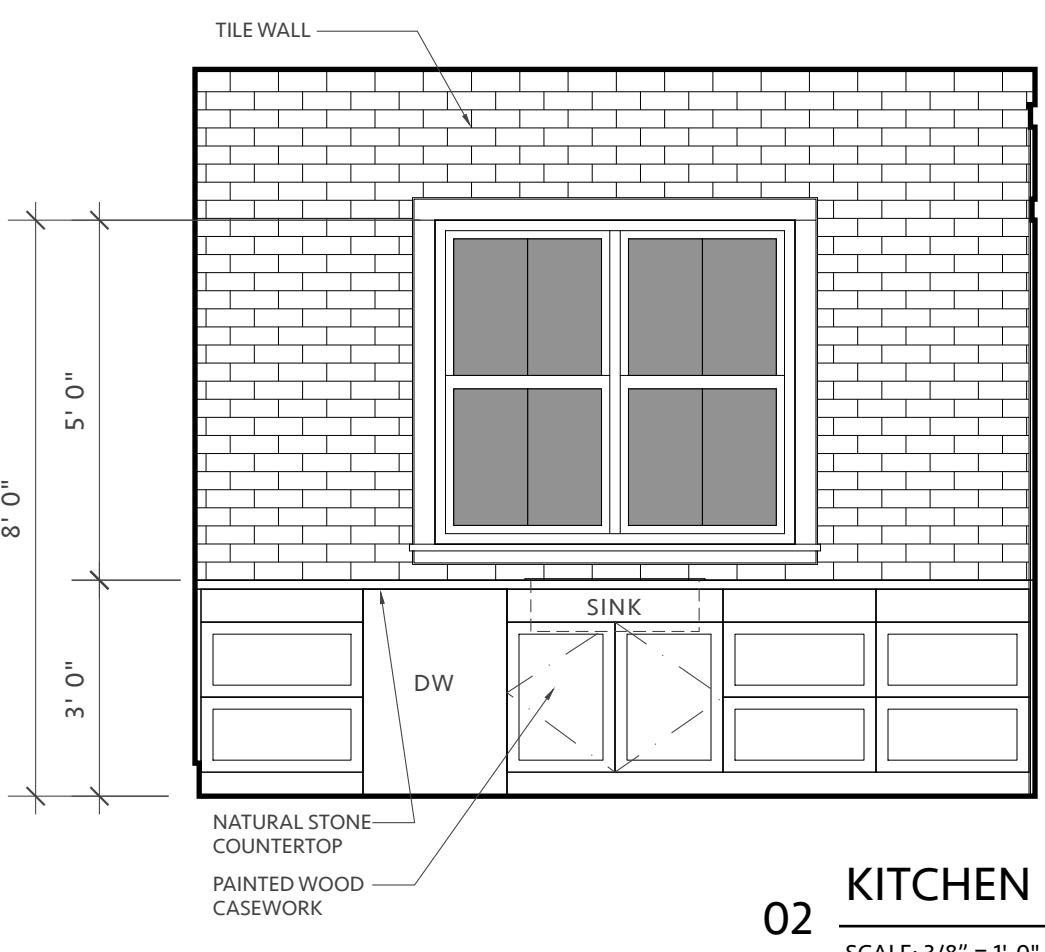

02 KITCHEN
SCALE: 3/8" = 1'-0"

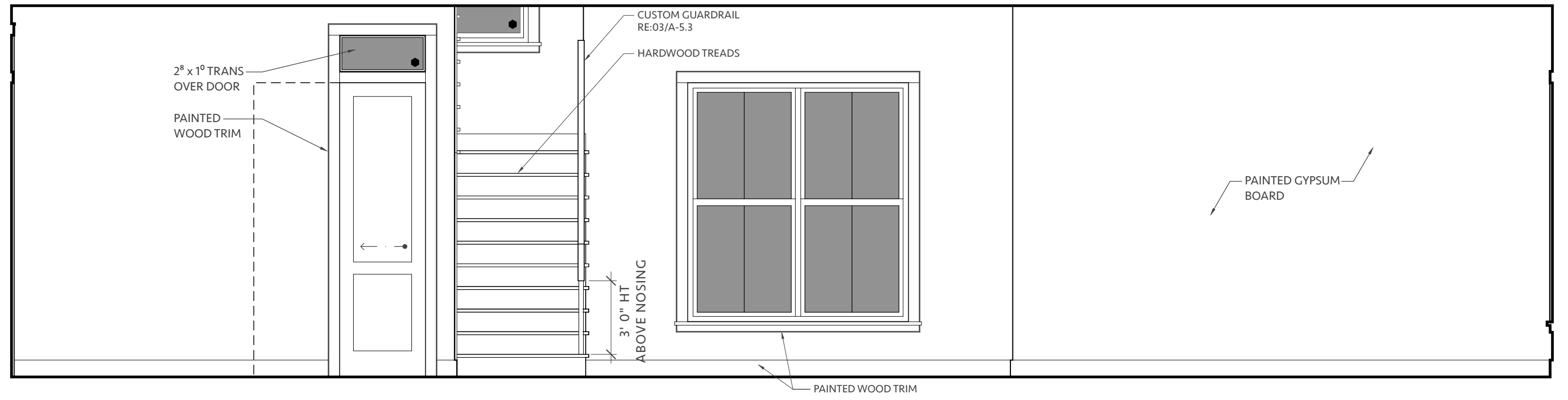
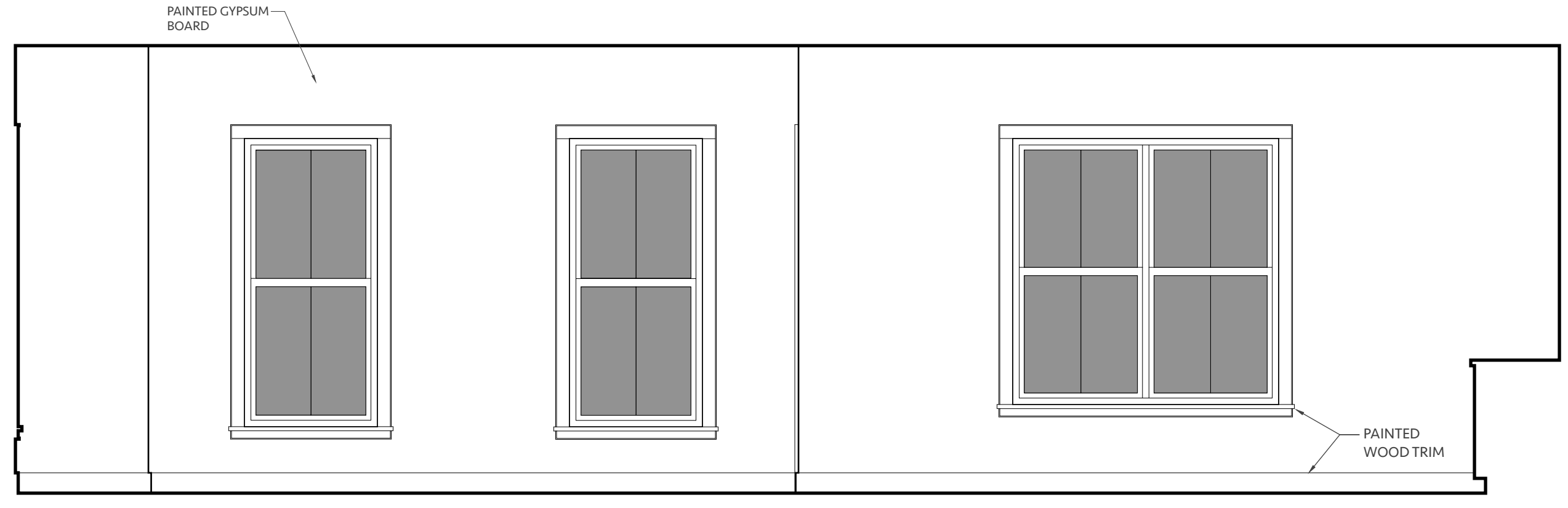

03 KITCHEN / LIVING
SCALE: 3/8" = 1'-0"

04 LIVING / DINING
SCALE: 3/8" = 1'-0"

SYMBOL LEGEND

TEMPERED GLASS: ●

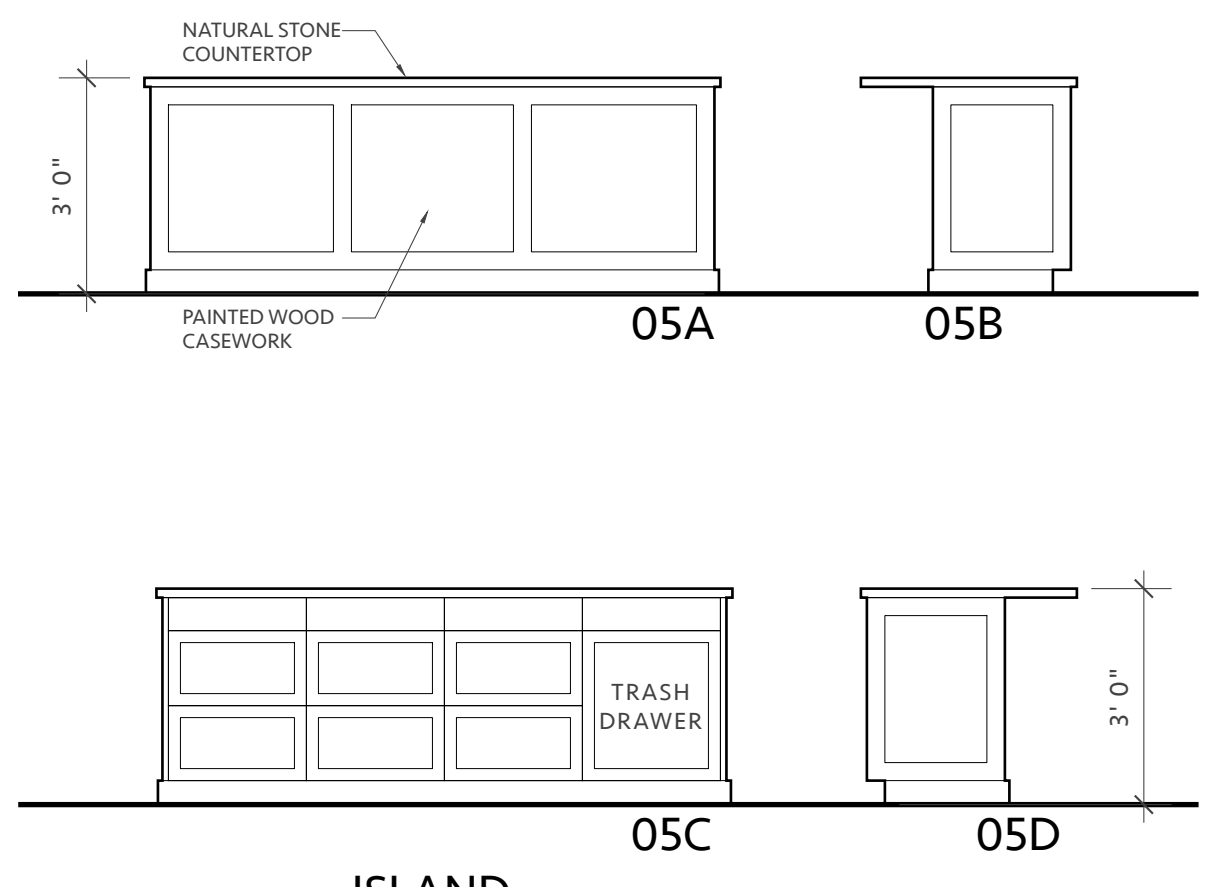

05 ISLAND
SCALE: 3/8" = 1'-0"

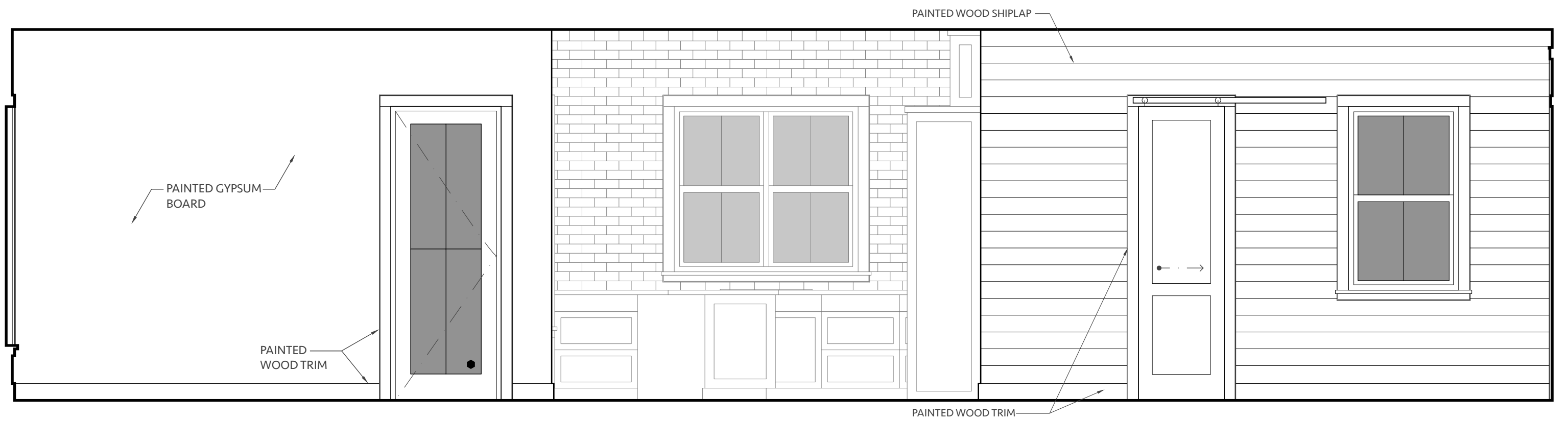

06 KITCHEN / LIVING
SCALE: 3/8" = 1'-0"

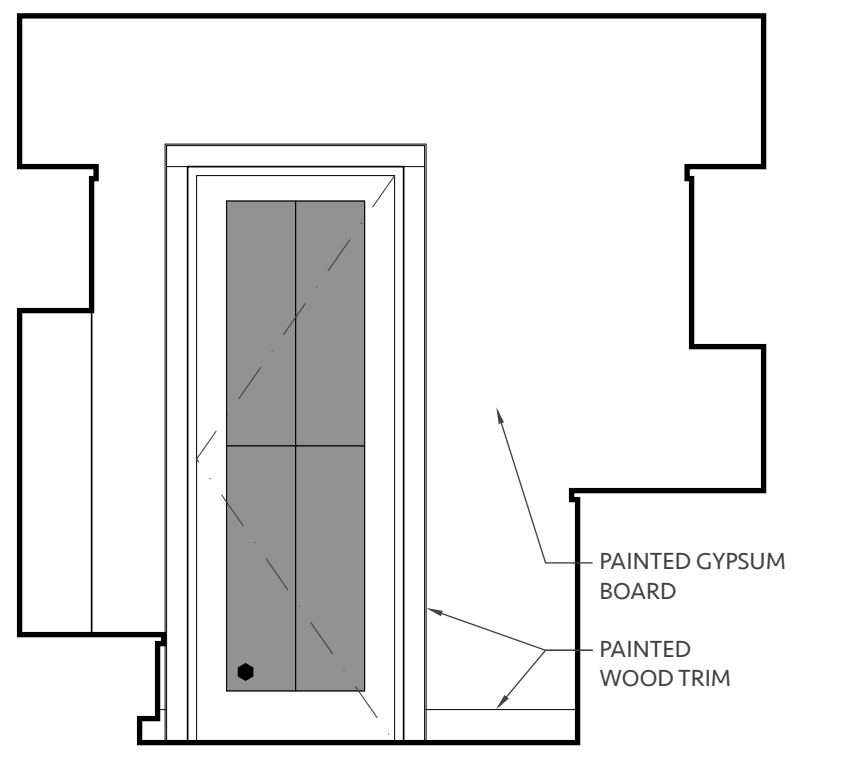

07 UTILITY
SCALE: 3/8" = 1'-0"

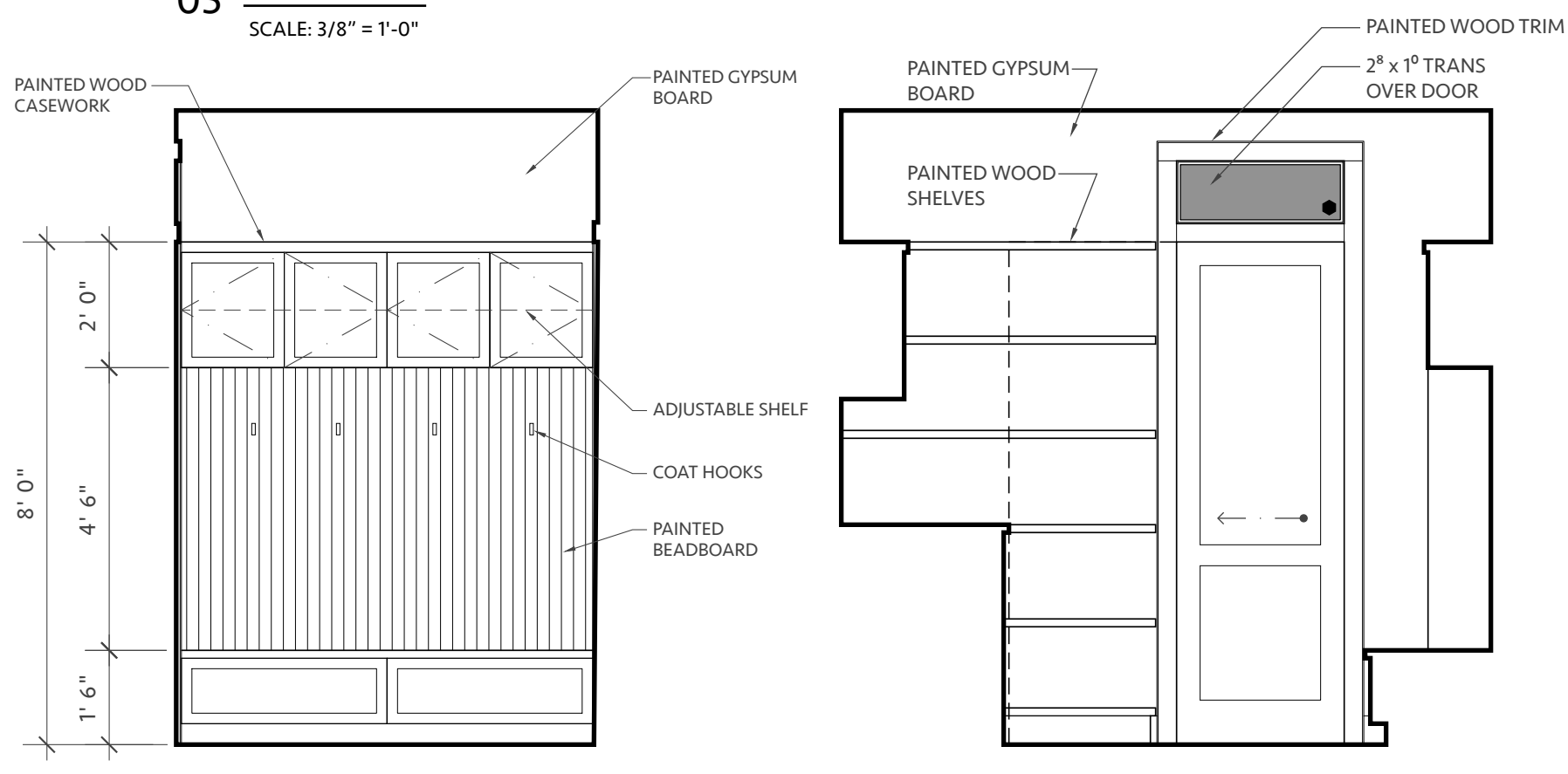

08 UTILITY
SCALE: 3/8" = 1'-0"

09 UTILITY
SCALE: 3/8" = 1'-0"

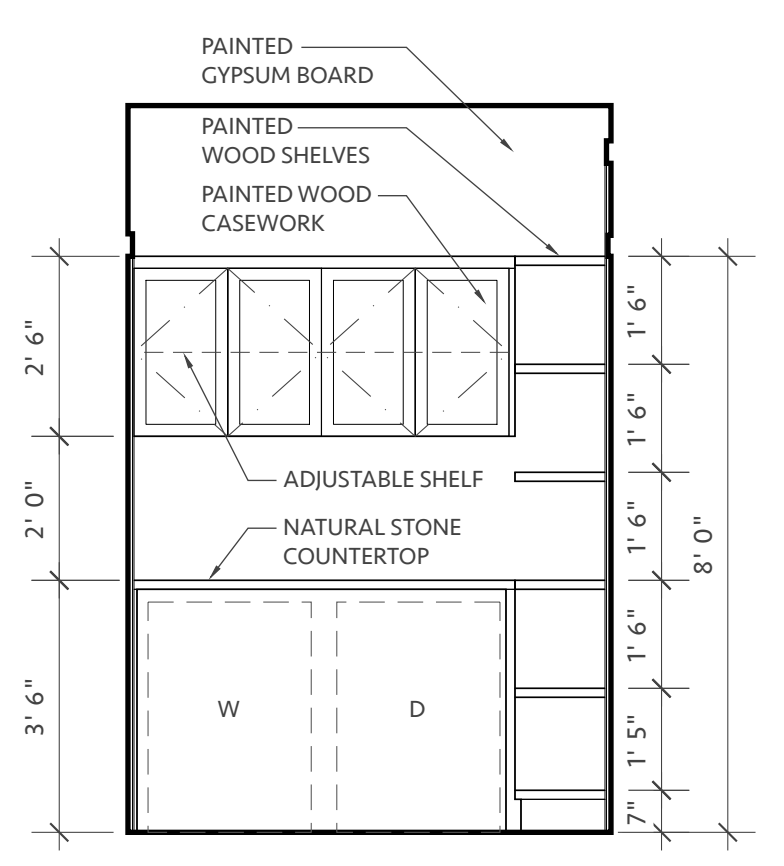

10 UTILITY
SCALE: 3/8" = 1'-0"

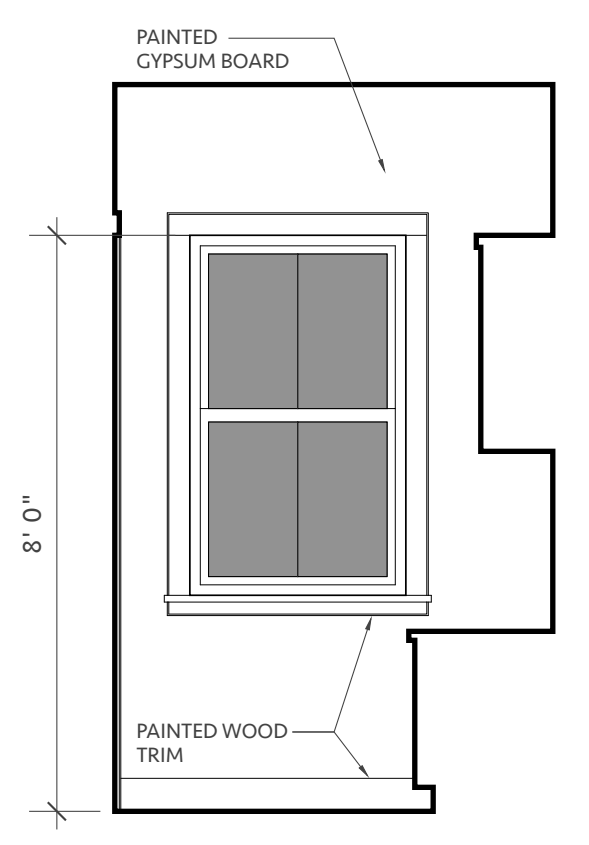

11 OFFICE
SCALE: 3/8" = 1'-0"

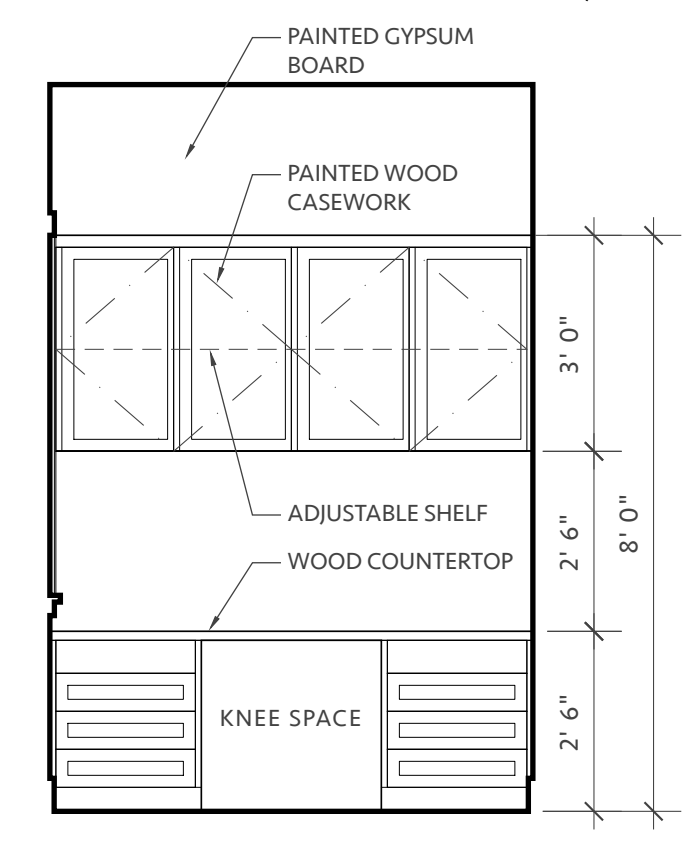

12 OFFICE
SCALE: 3/8" = 1'-0"

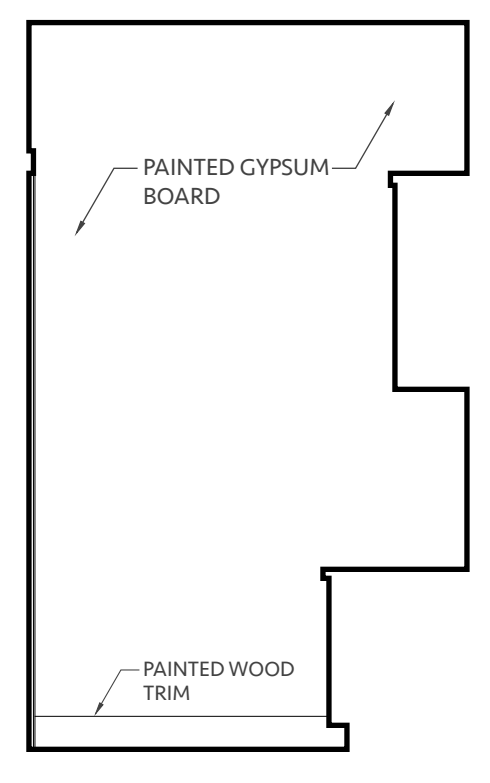

13 OFFICE
SCALE: 3/8" = 1'-0"

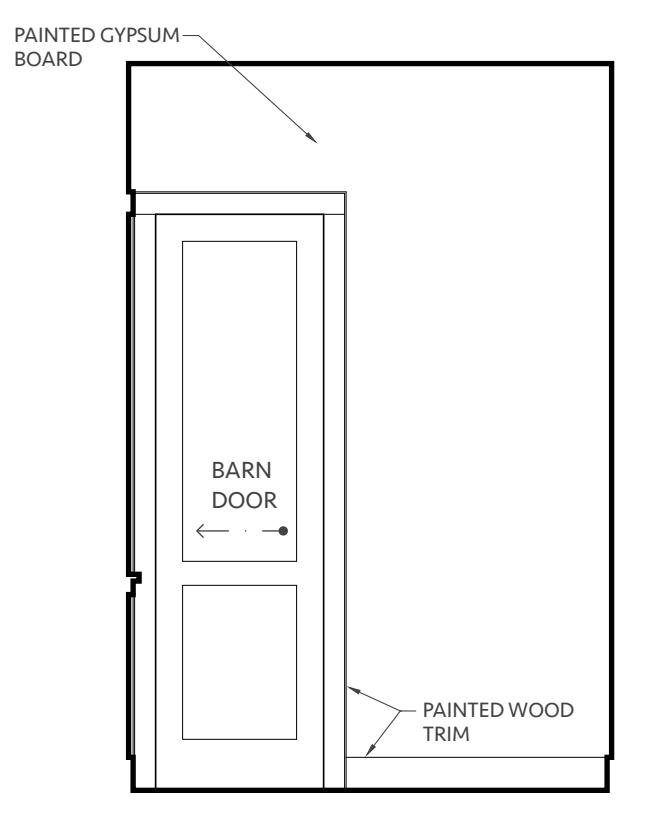

14 OFFICE
SCALE: 3/8" = 1'-0"

PERCH PLANS

NAME: ALDERNEY FARMHOUSE
 ADDRESS: LOT 1 HOLLAND ST.
 CITY: BELLVILLE, ST TX ZIP: 77418
 PERCH PLANS, LLC
 100 BRAZOS ST. AUSTIN, TX 78701
 P: 512-817-1999

DATE: 20 JUL. 2017
 JOB #:
 A-4-1
 8 of 14

REGISTERED ARCHITECT
 MONTY A. BROWN
 2015
 STATE OF TEXAS

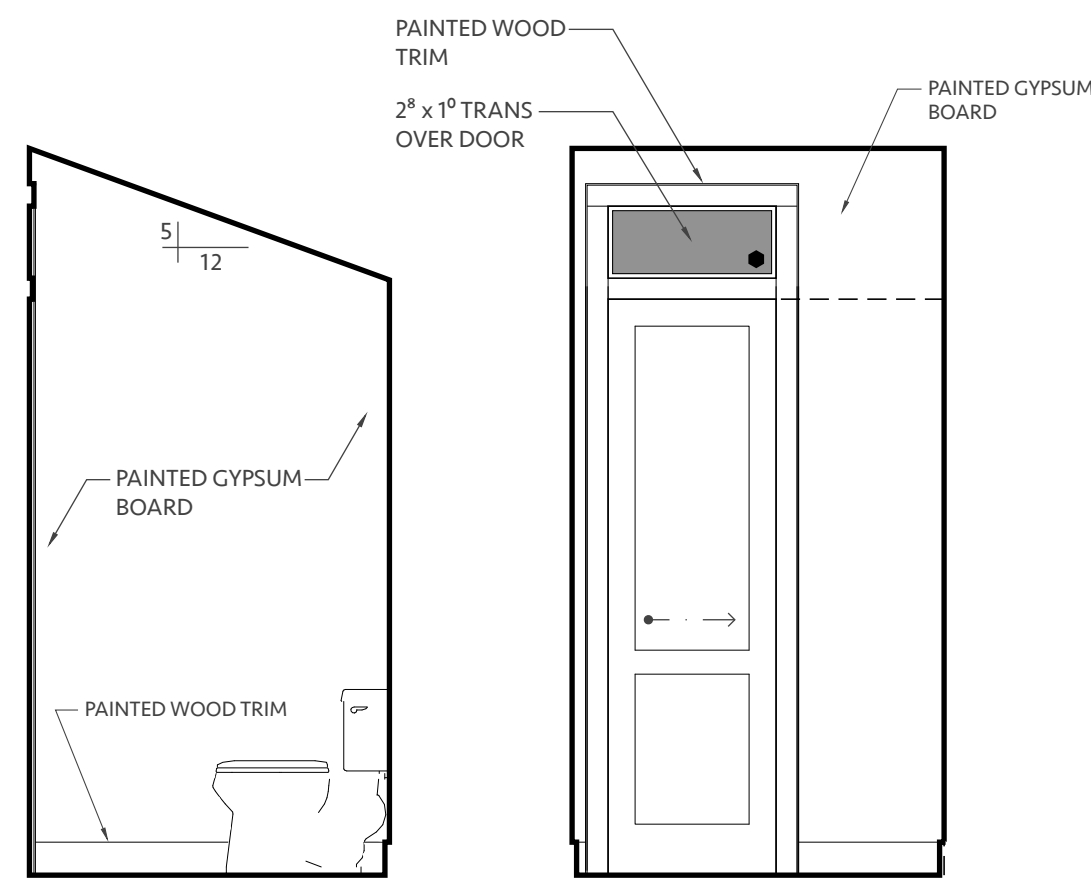

15 POWDER
SCALE: 3/8" = 1'-0"

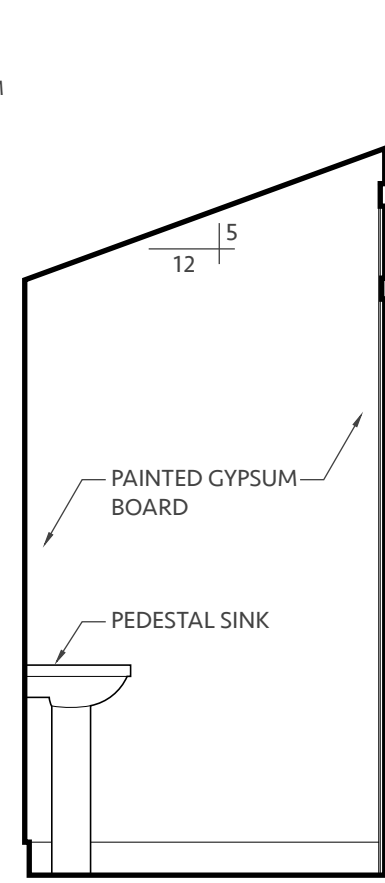

17 POWDER
SCALE: 3/8" = 1'-0"

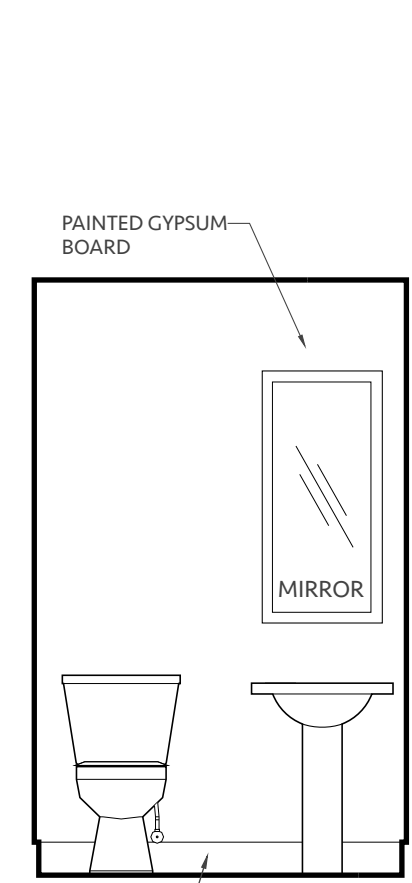

18 POWDER
SCALE: 3/8" = 1'-0"

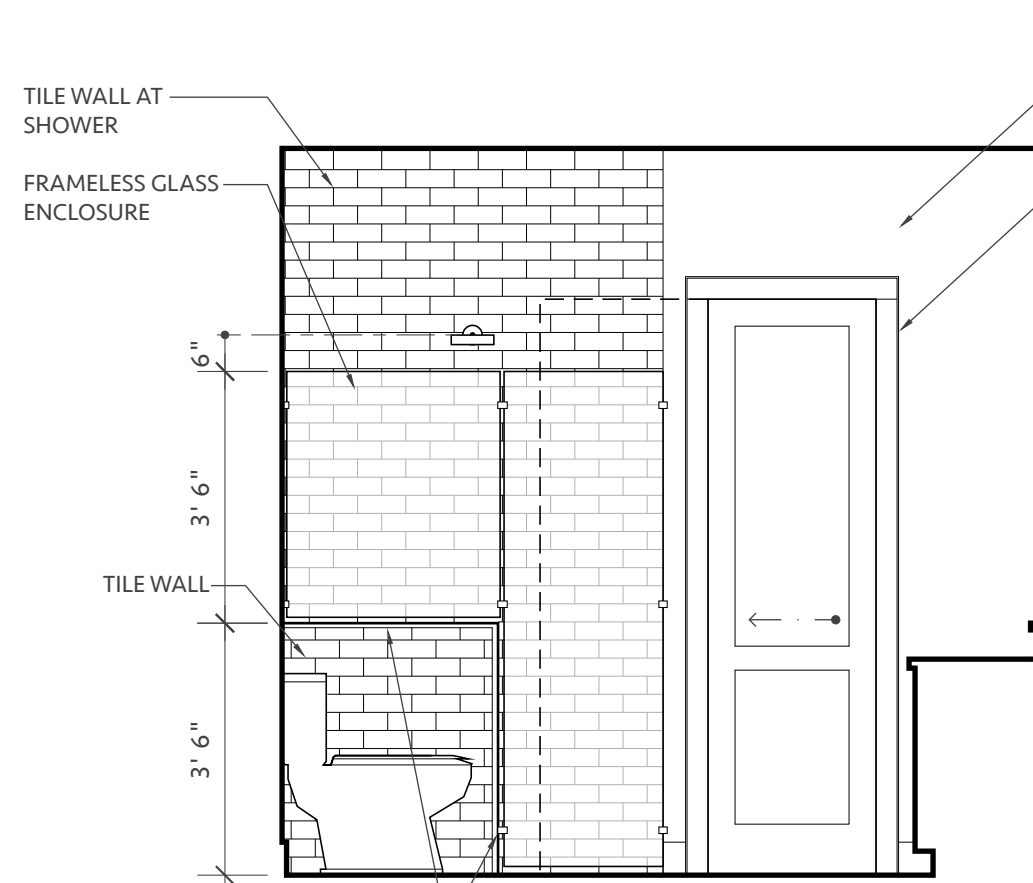

19 MASTER BATH
SCALE: 3/8" = 1'-0"

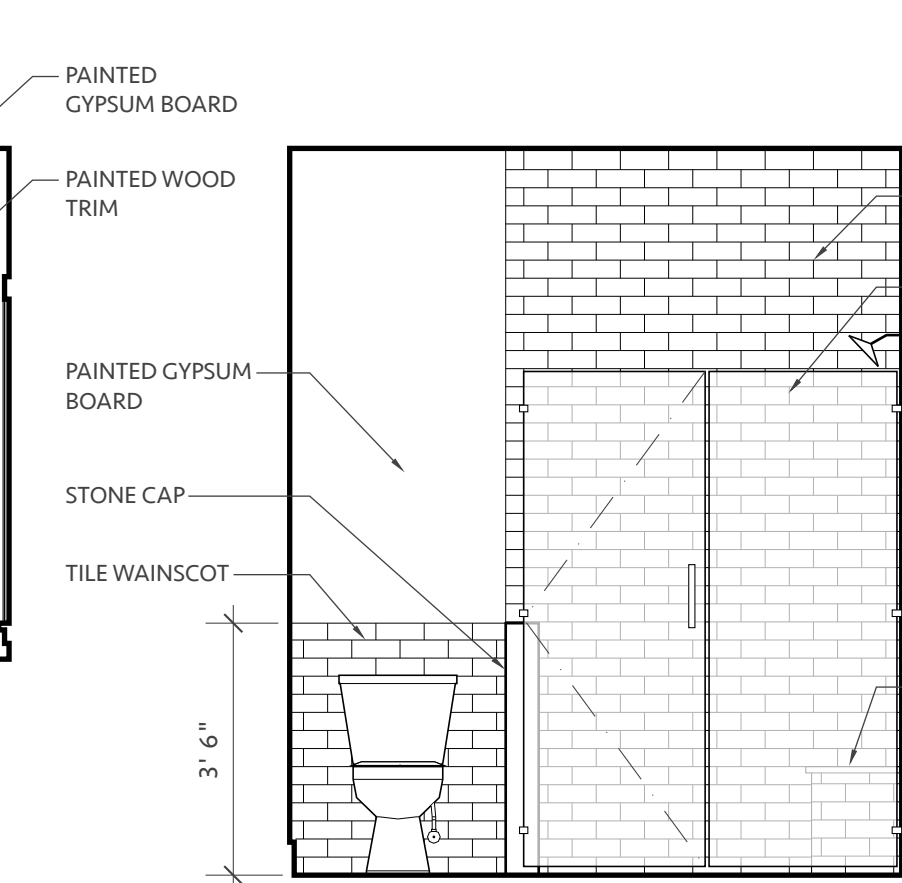

20 MASTER BATH
SCALE: 3/8" = 1'-0"

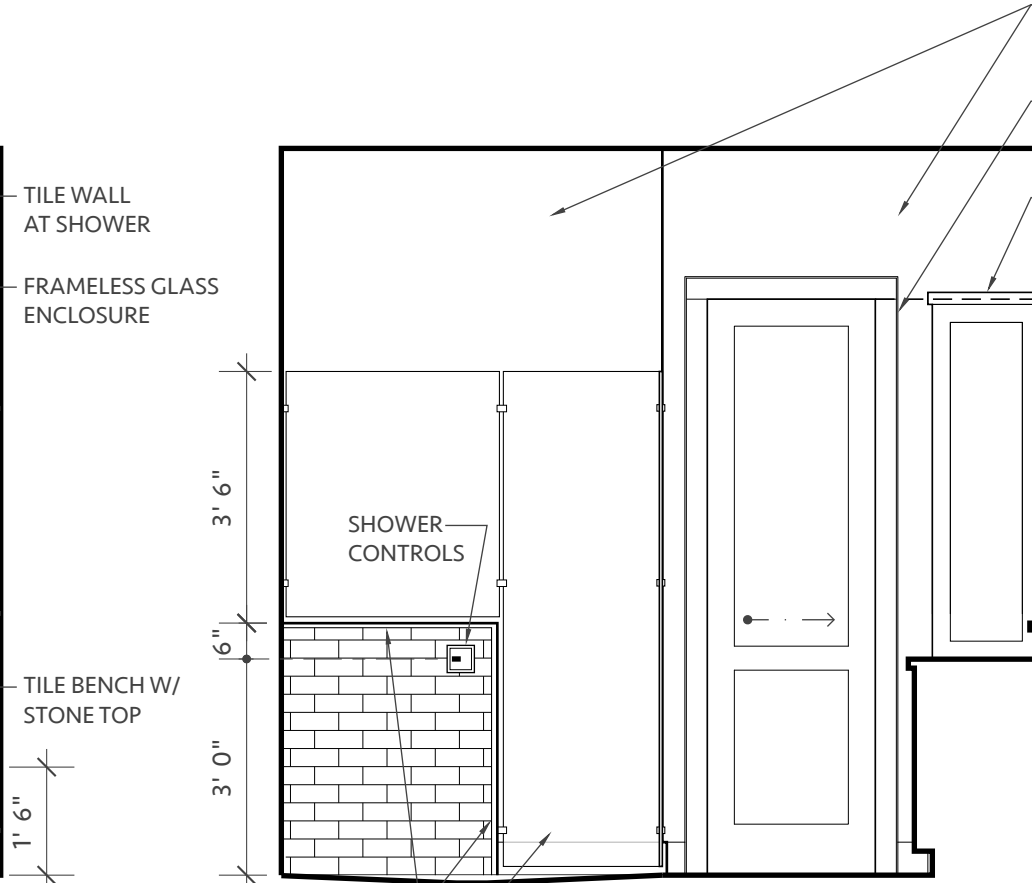

21 MASTER BATH
SCALE: 3/8" = 1'-0"

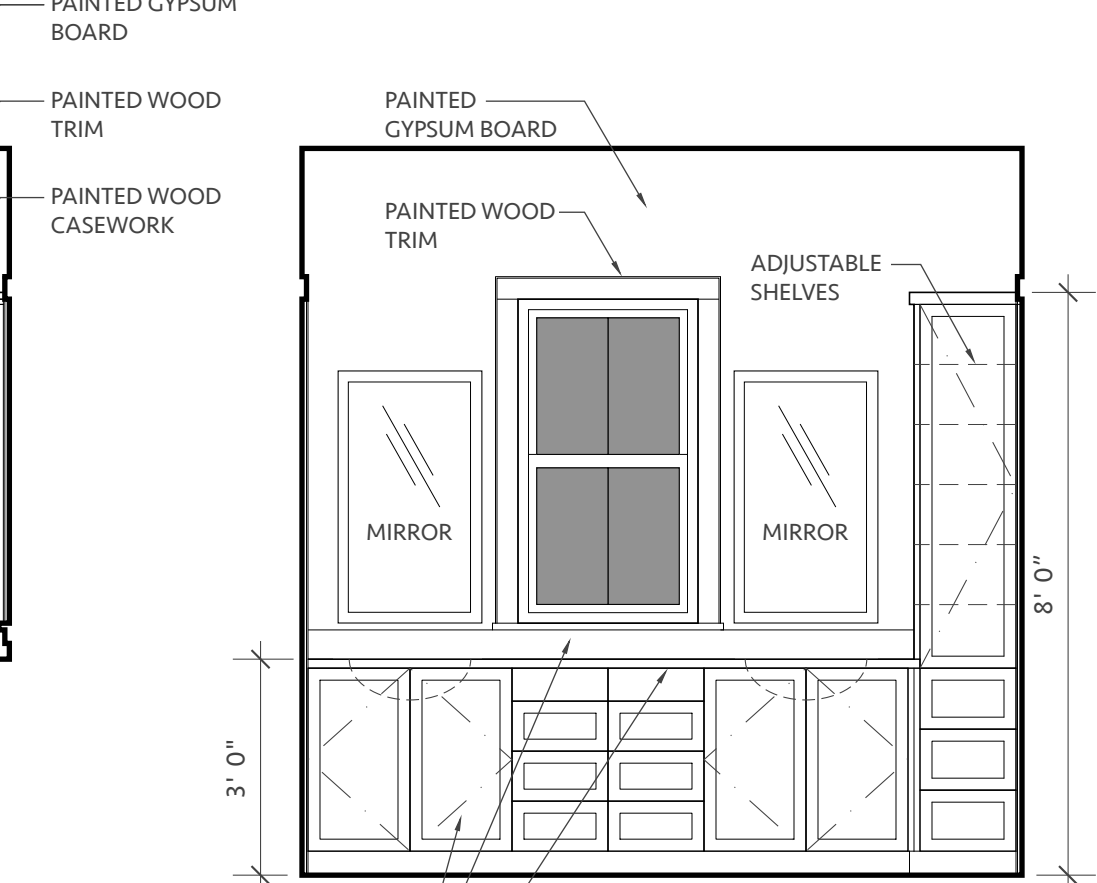

22 MASTER BATH
SCALE: 3/8" = 1'-0"

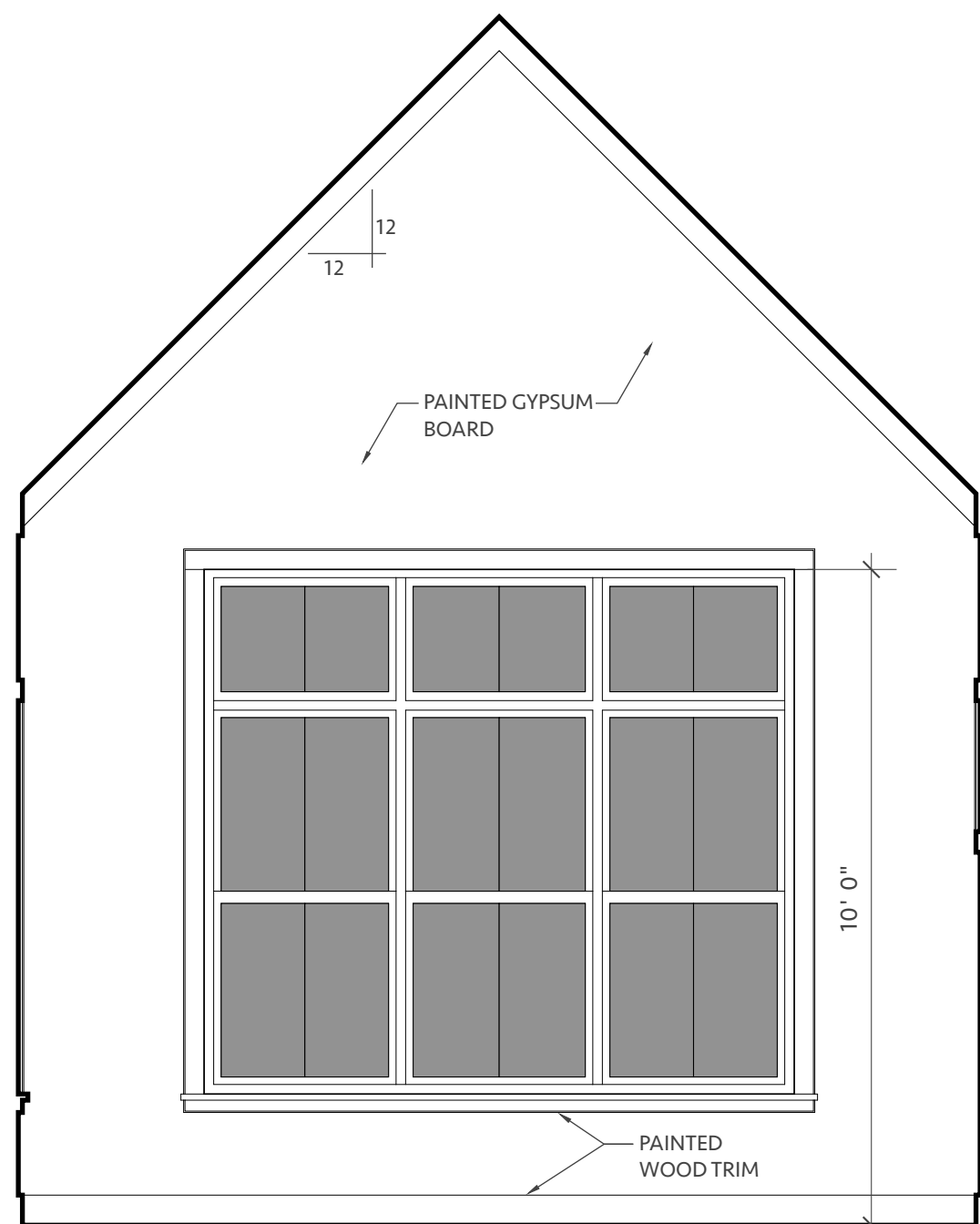

23 MASTER BEDROOM
SCALE: 3/8" = 1'-0"

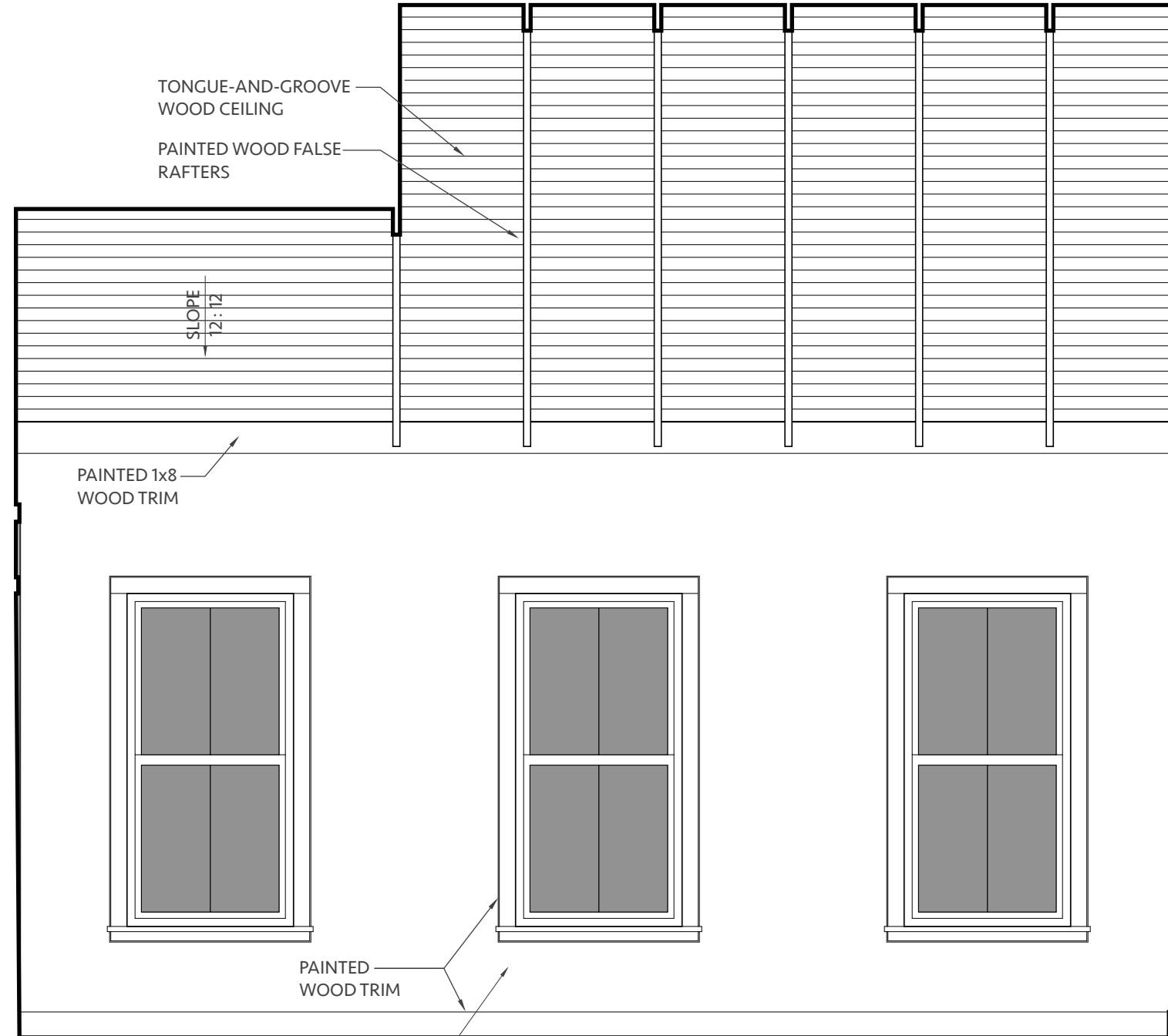

24 MASTER BEDROOM
SCALE: 3/8" = 1'-0"

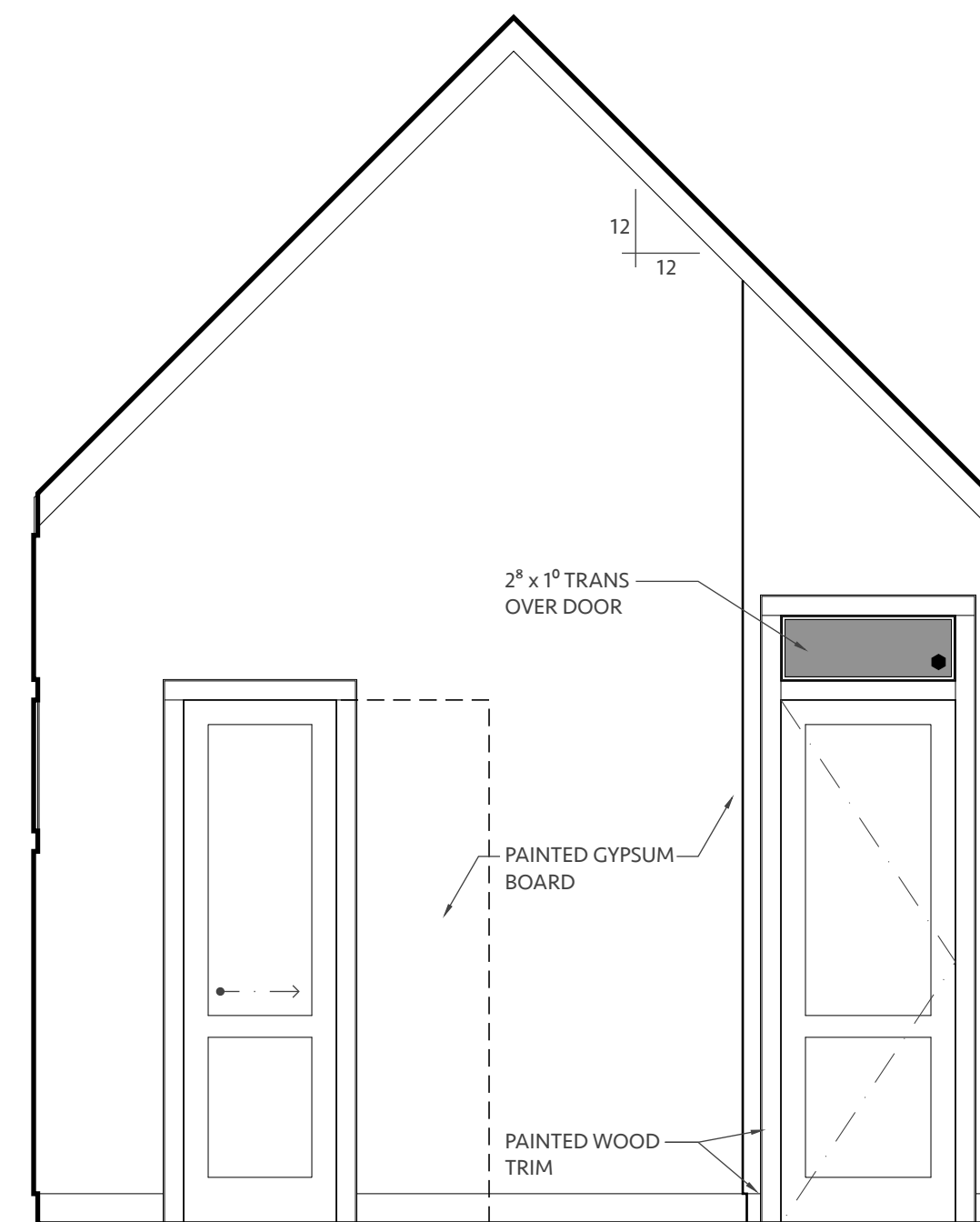

25 MASTER BEDROOM
SCALE: 3/8" = 1'-0"

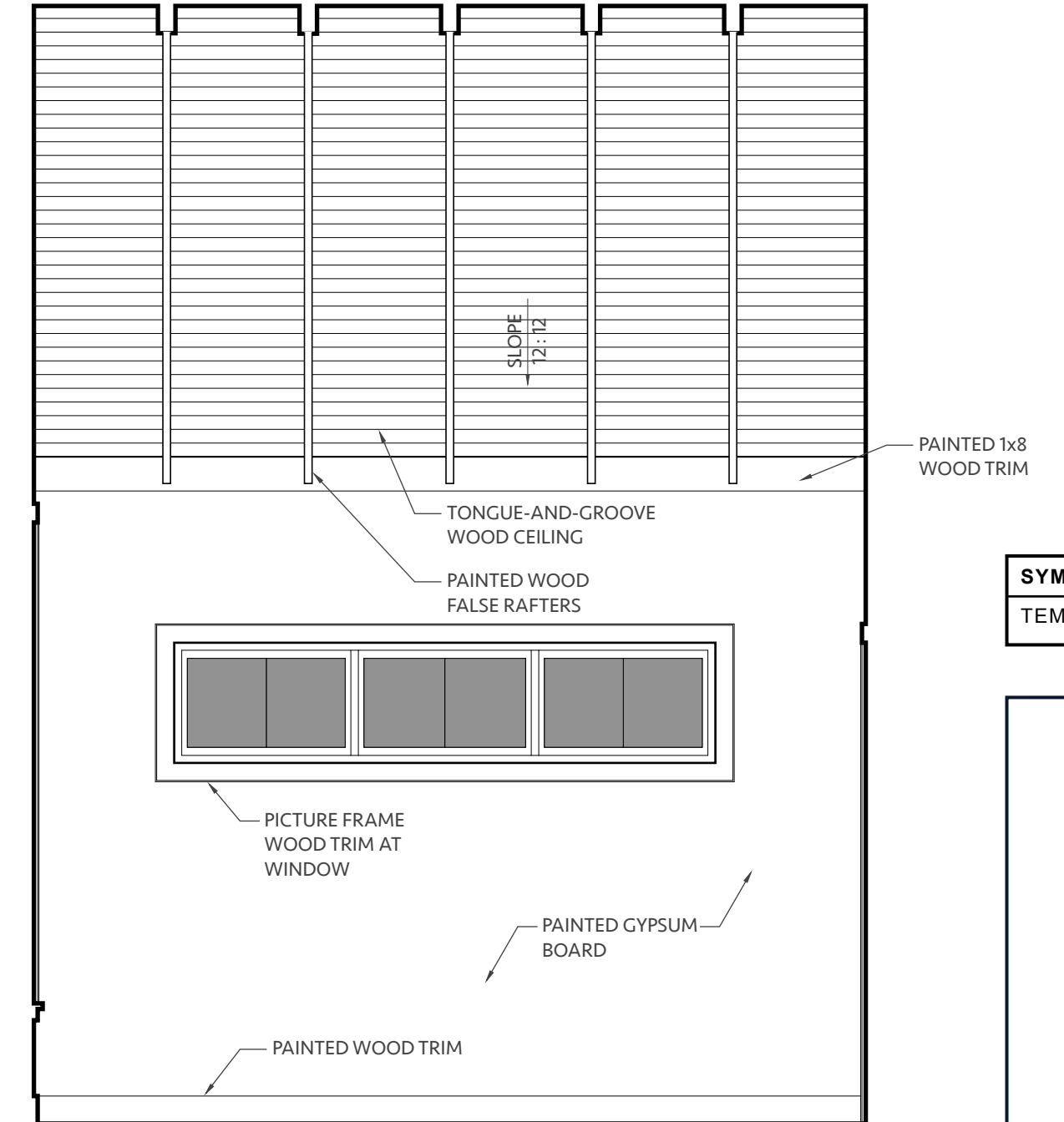

26 MASTER BEDROOM
SCALE: 3/8" = 1'-0"

SYMBOL LEGEND
TEMPERED GLASS: ●

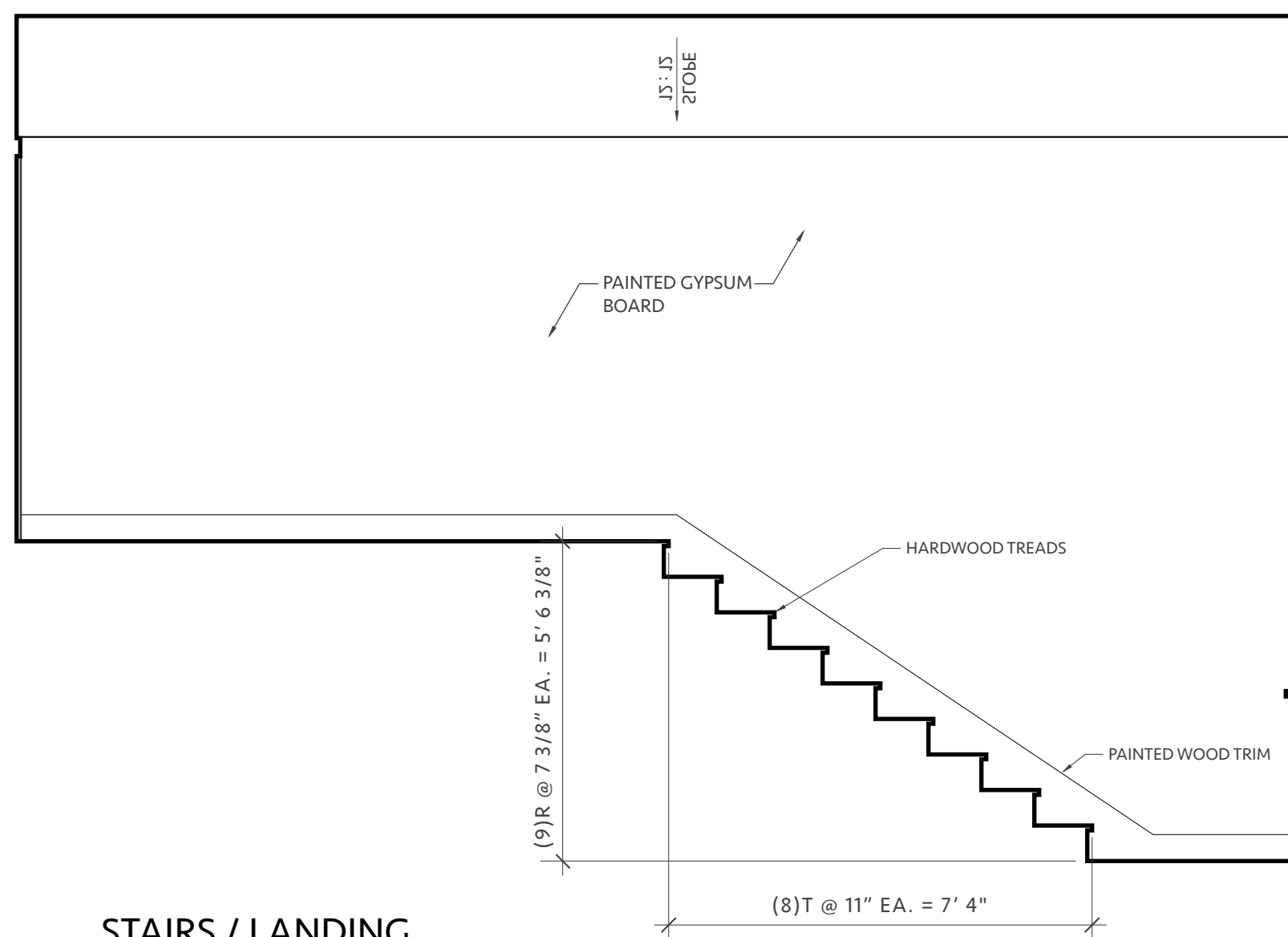

27 STAIRS / LANDING
SCALE: 3/8" = 1'-0"

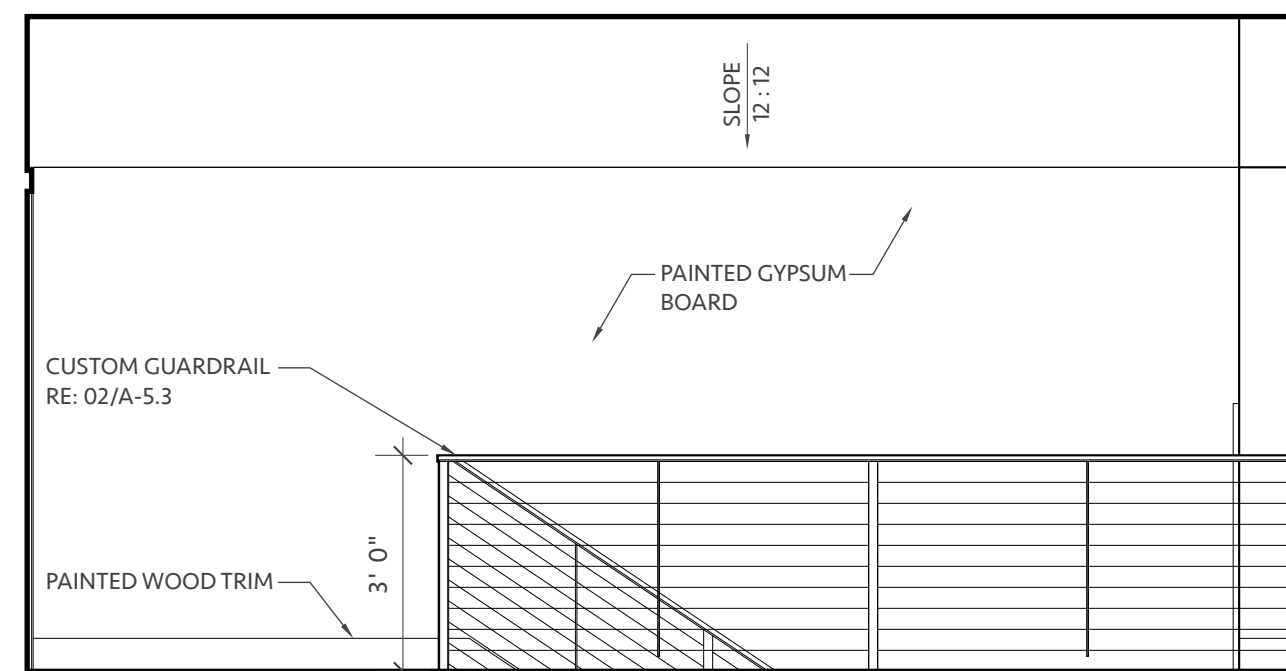

28 LANDING
SCALE: 3/8" = 1'-0"

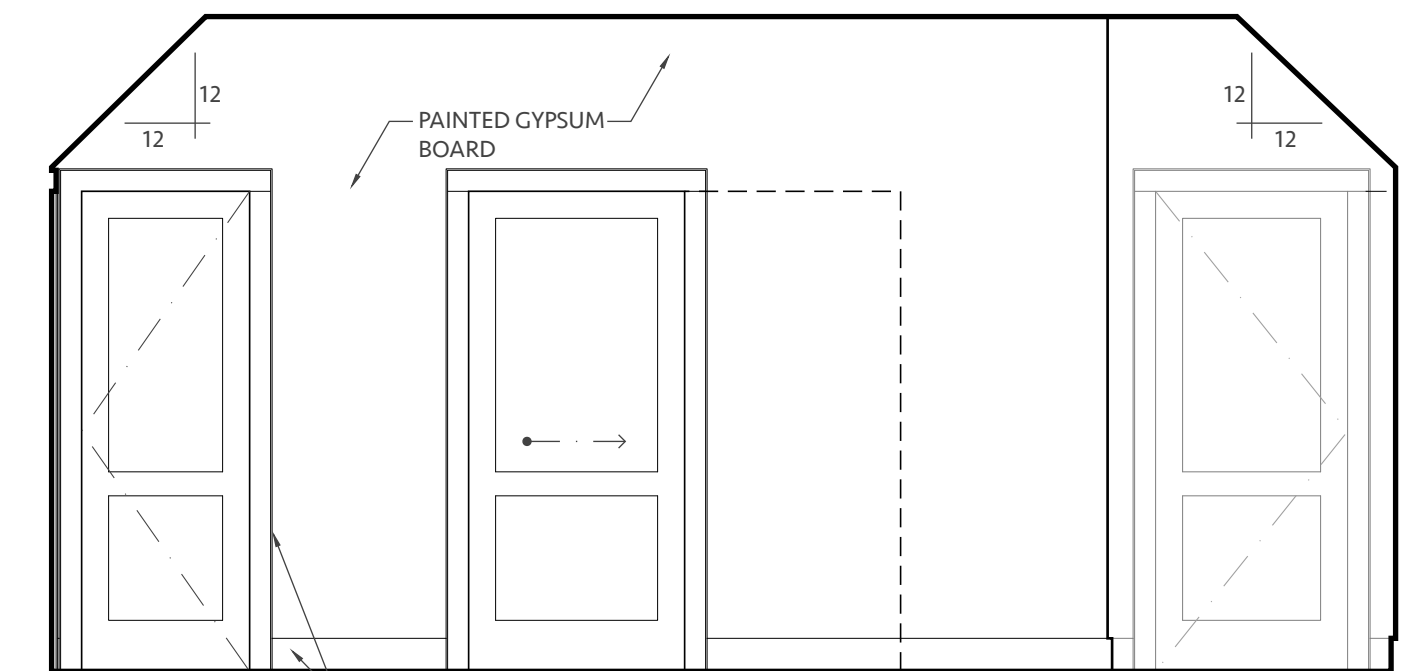

29 LANDING
SCALE: 3/8" = 1'-0"

PERCH PLANS

NAME ALDERNEY FARMHOUSE
ADDRESS LOT 1 HOLLAND ST.
CITY BELLVILLE, ST TX ZIP 77418
PERCH PLANS, LLC 100 BRAZOS ST
AUSTIN, TX 78701
H-844-817-1999

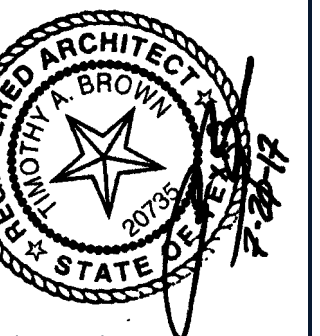

DATE 20 JUL. 2017

JOB #
A-4.2
9 of 14

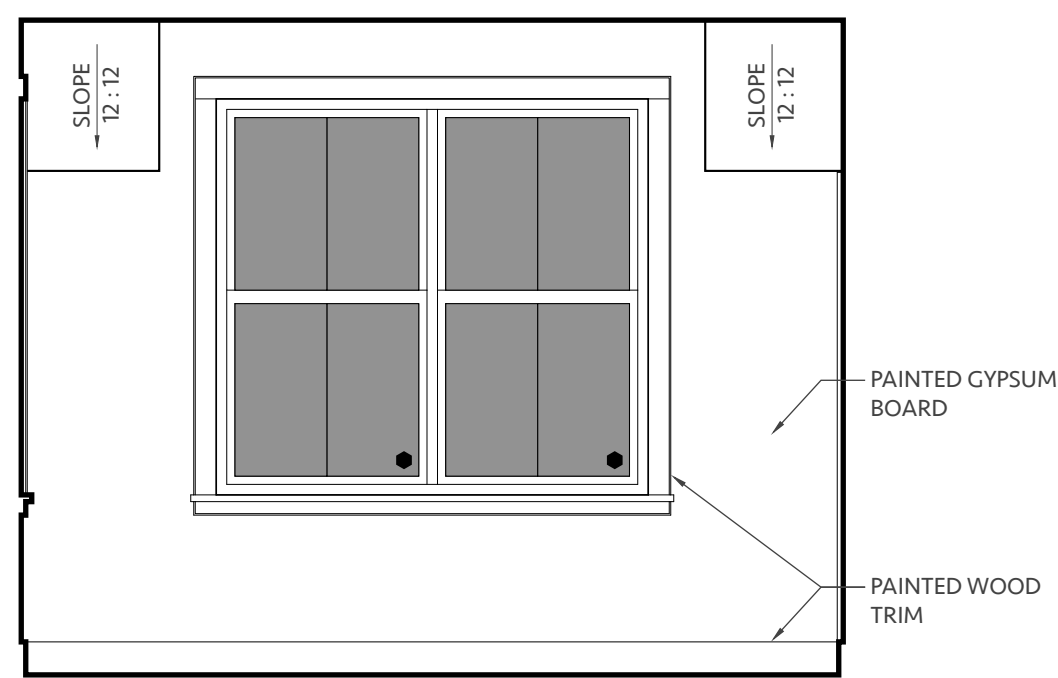

32 **BEDROOM 2**
SCALE: 3/8" = 1'-0"

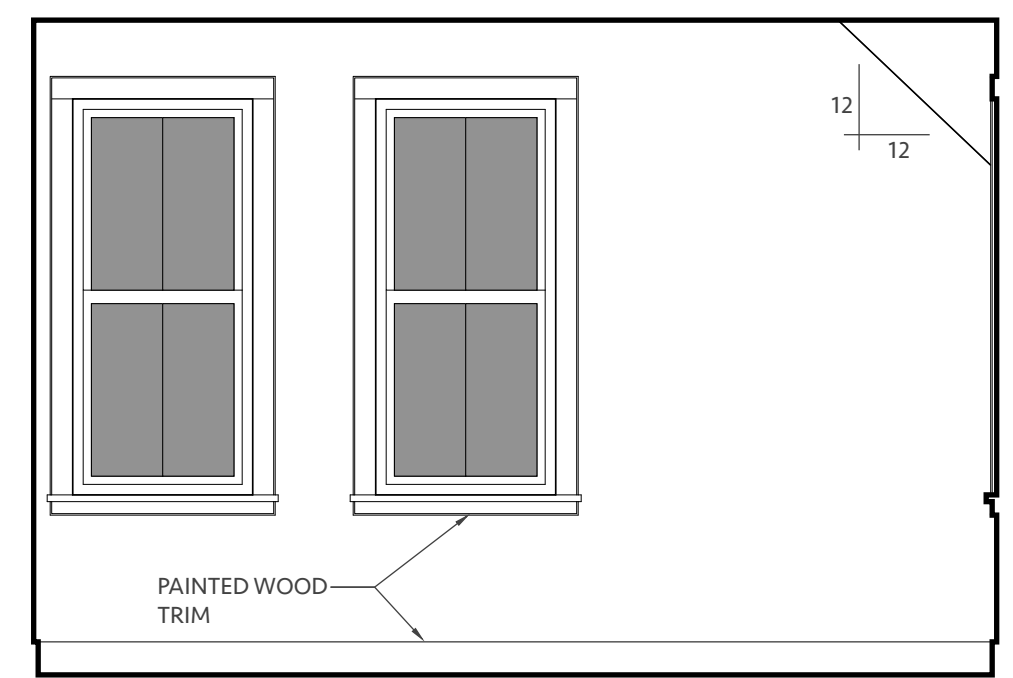

33 **BEDROOM 2**
SCALE: 3/8" = 1'-0"

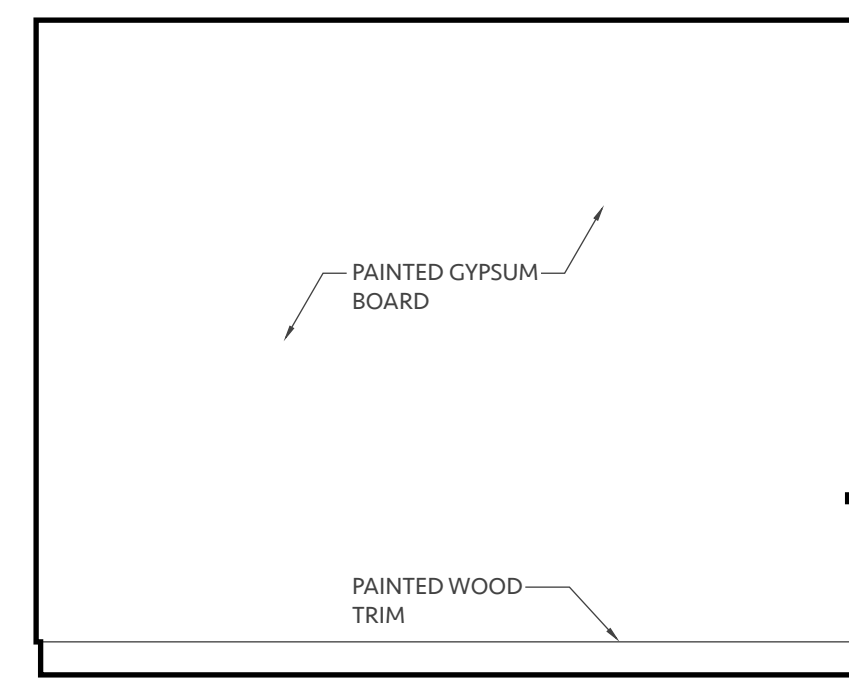

34 **BEDROOM 2**
SCALE: 3/8" = 1'-0"

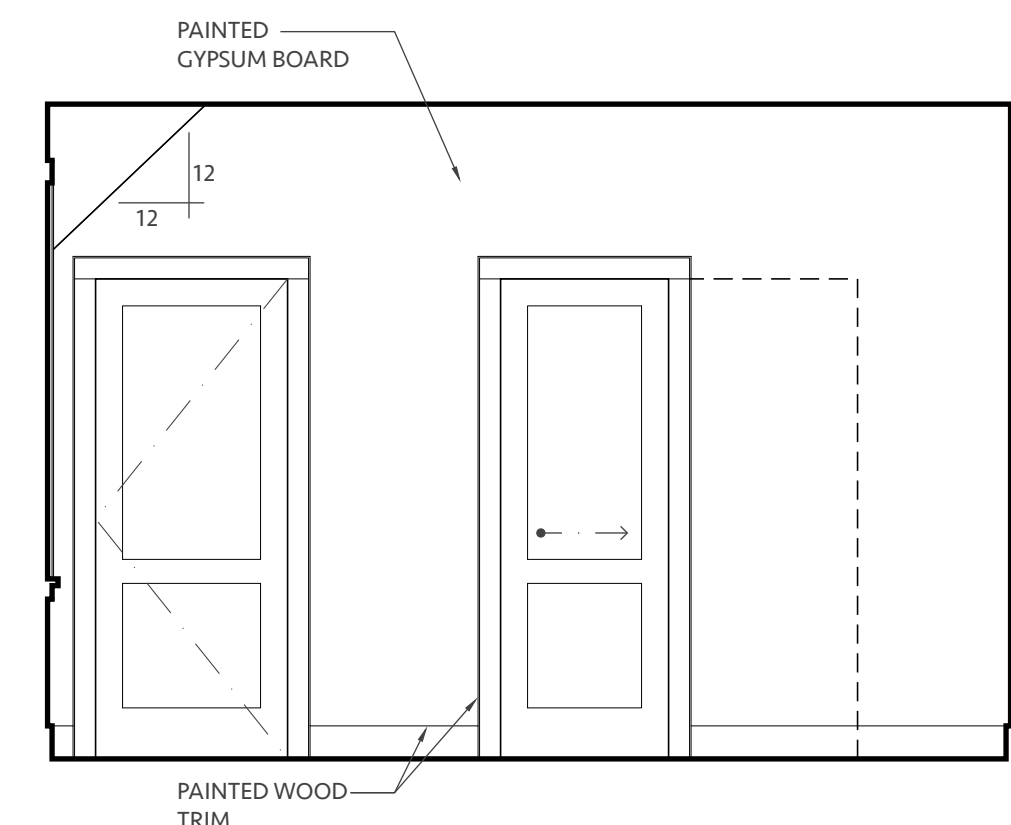

35 **BEDROOM 2**
SCALE: 3/8" = 1'-0"

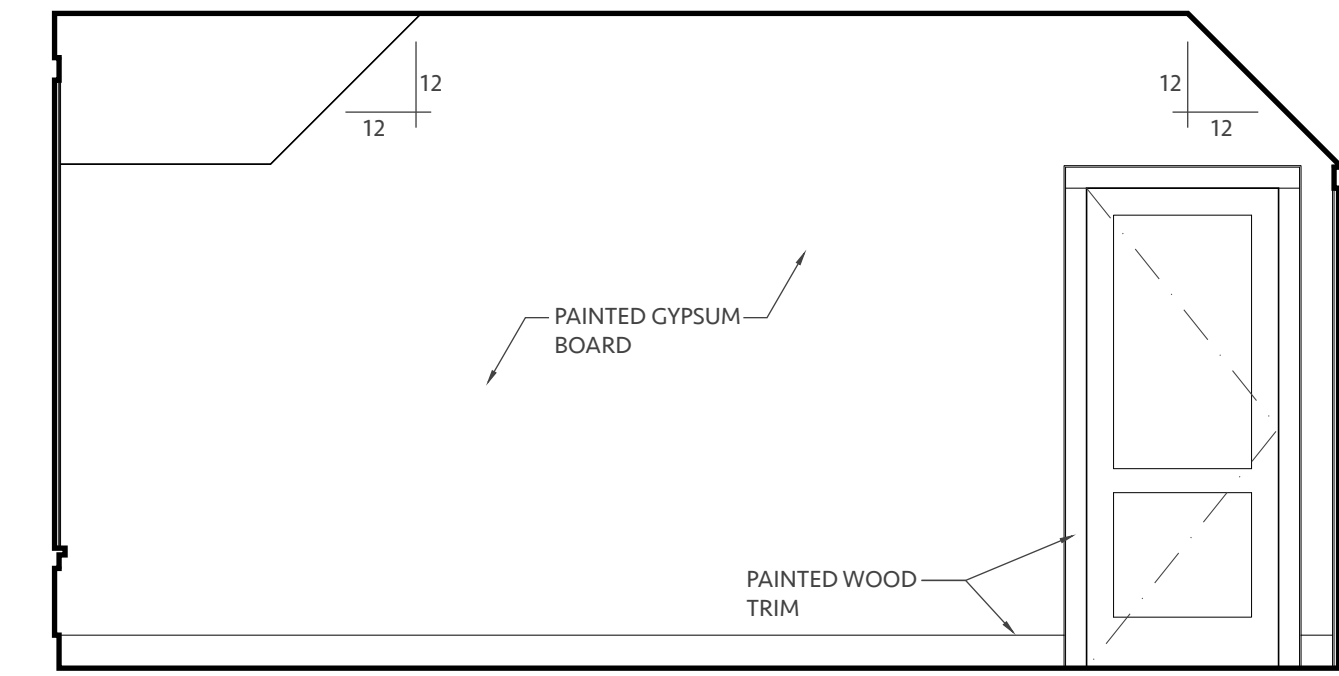

30 **LANDING**
SCALE: 3/8" = 1'-0"

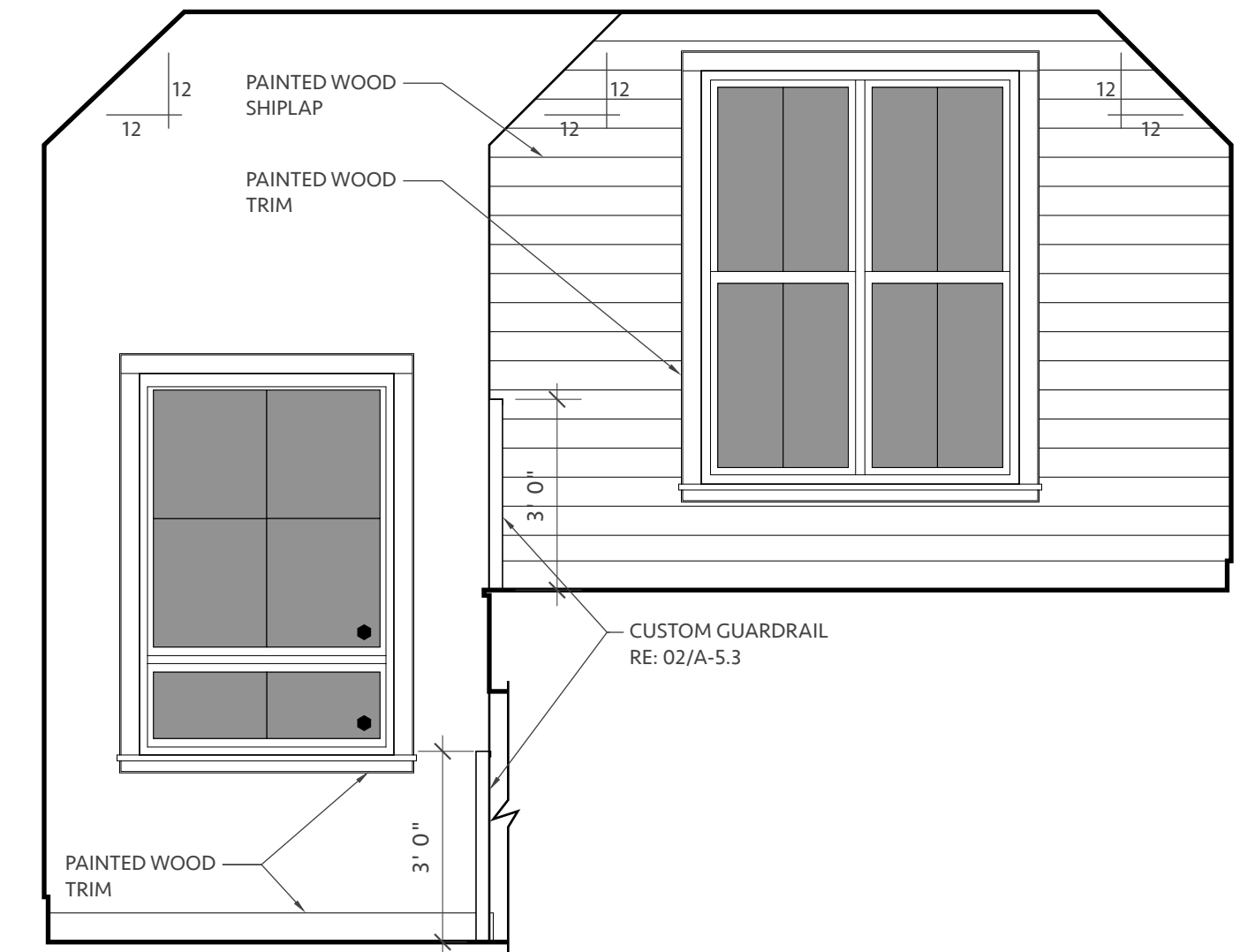

31 **LANDING**
SCALE: 3/8" = 1'-0"

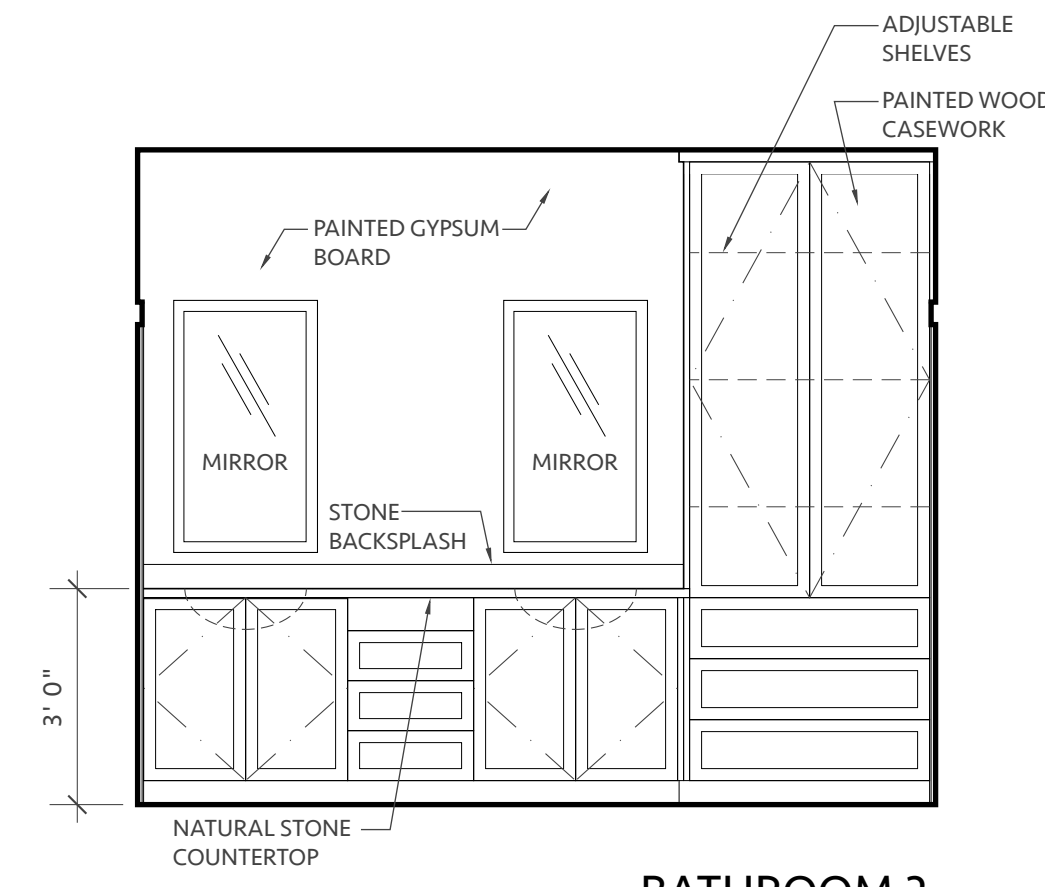

36 **BATHROOM 2**
SCALE: 3/8" = 1'-0"

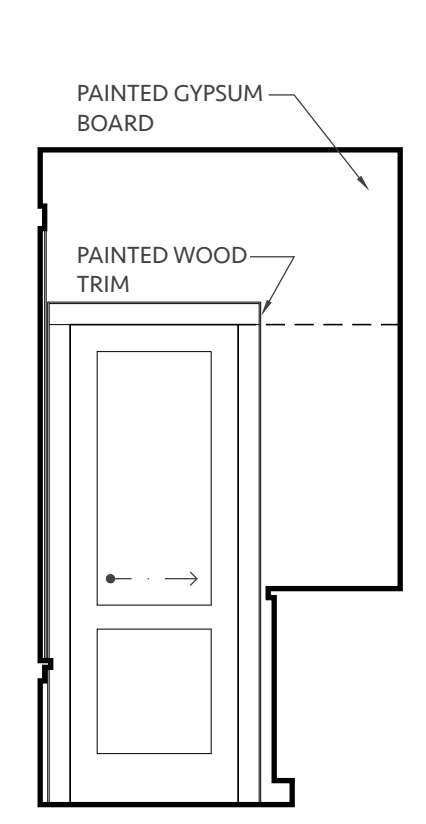

37 **BATHROOM 2**
SCALE: 3/8" = 1'-0"

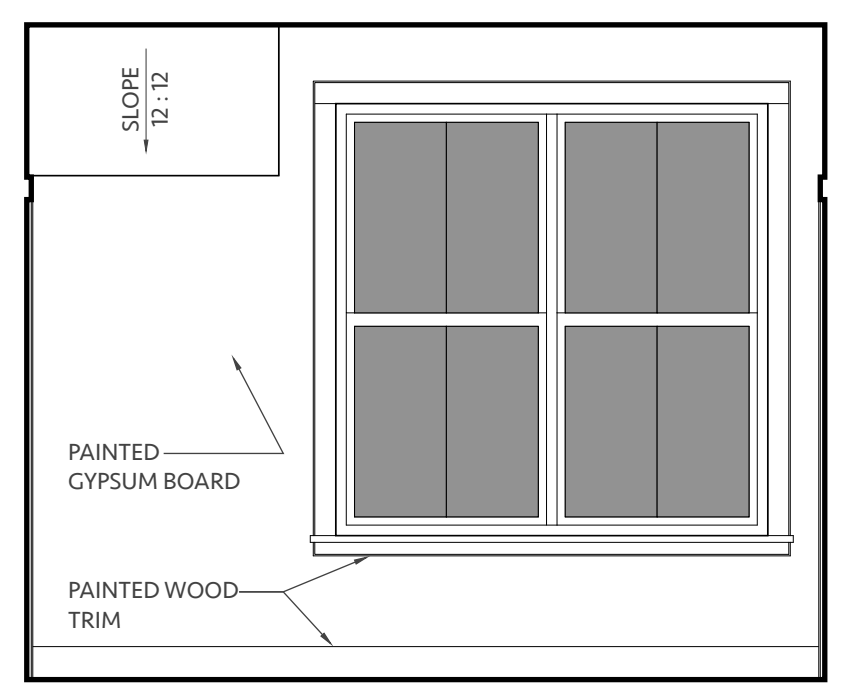

38 **BATHROOM 2**
SCALE: 3/8" = 1'-0"



39 **BATHROOM 2**
SCALE: 3/8" = 1'-0"

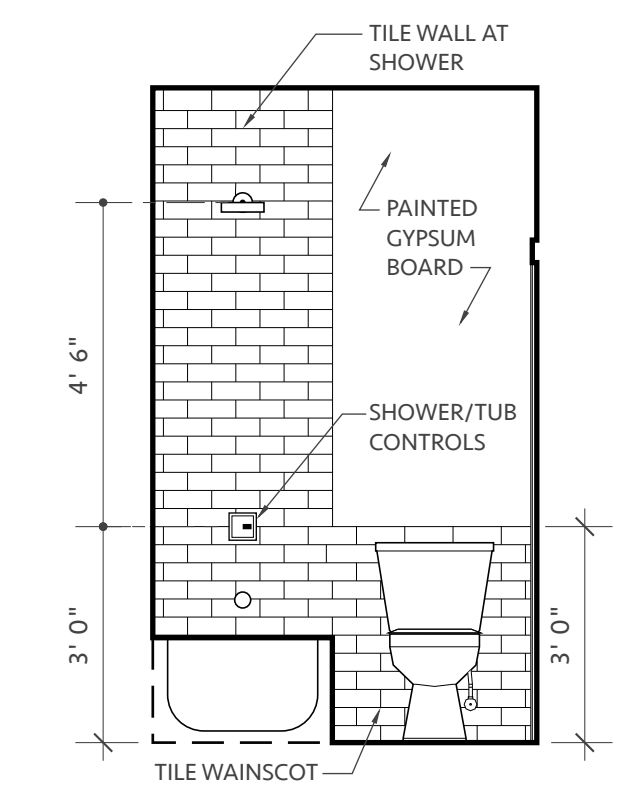

40 **BATHROOM 2**
SCALE: 3/8" = 1'-0"

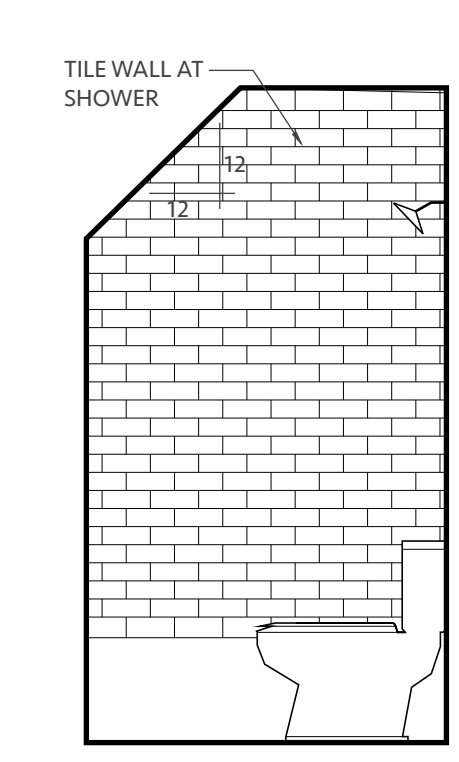

41 **BATHROOM 2**
SCALE: 3/8" = 1'-0"

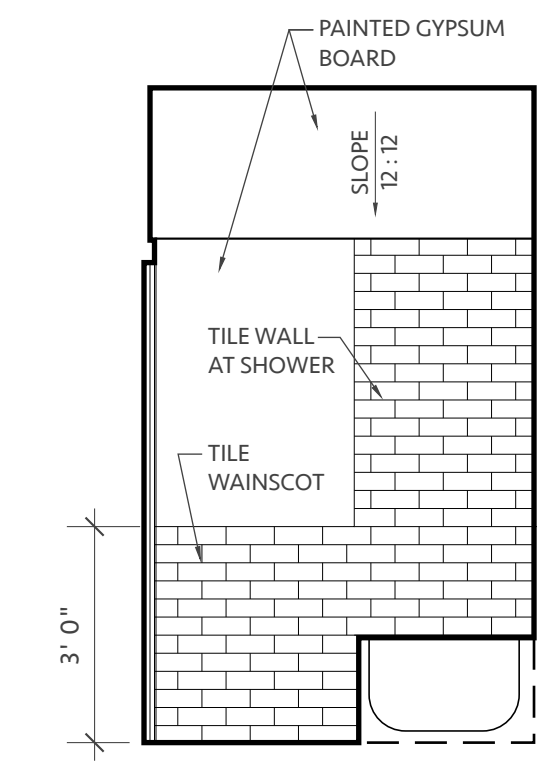

42 **BATHROOM 2**
SCALE: 3/8" = 1'-0"

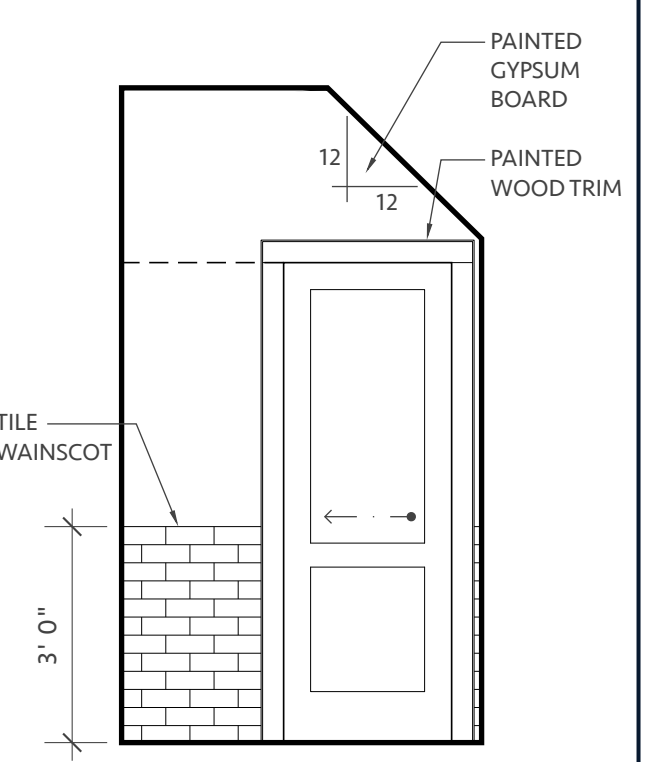

43 **BATHROOM 2**
SCALE: 3/8" = 1'-0"

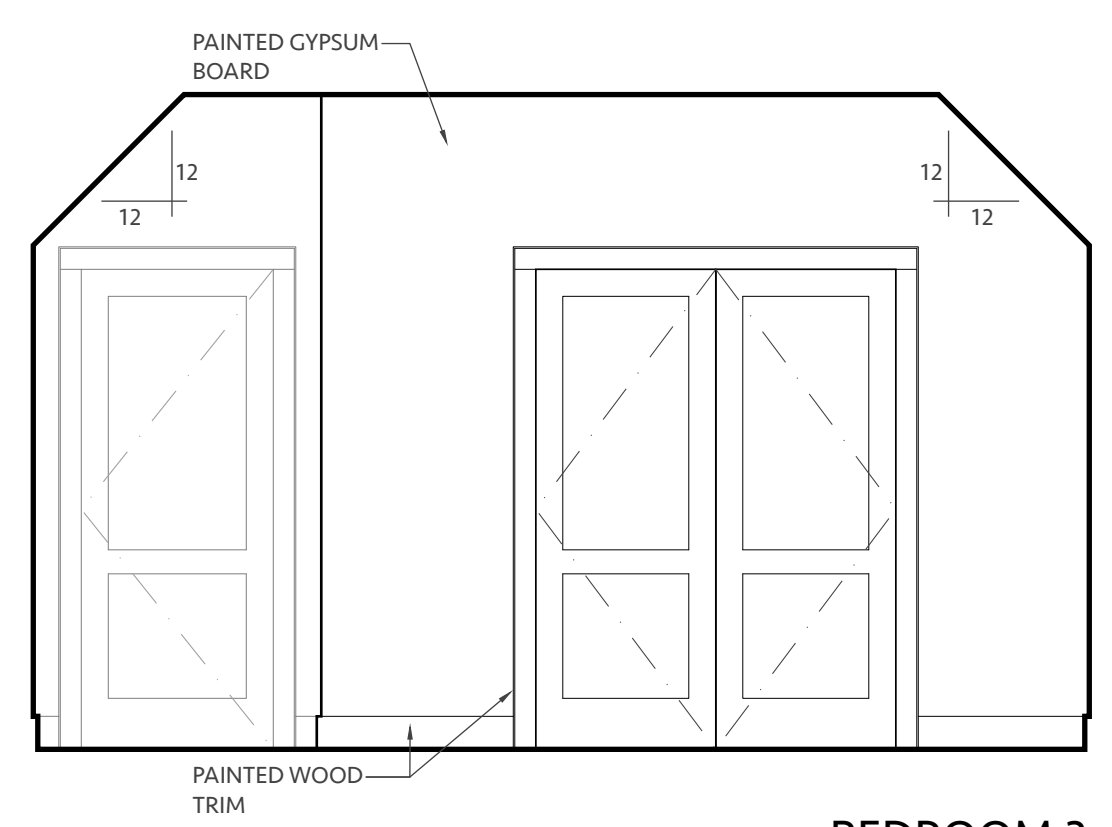

44 **BEDROOM 3**
SCALE: 3/8" = 1'-0"

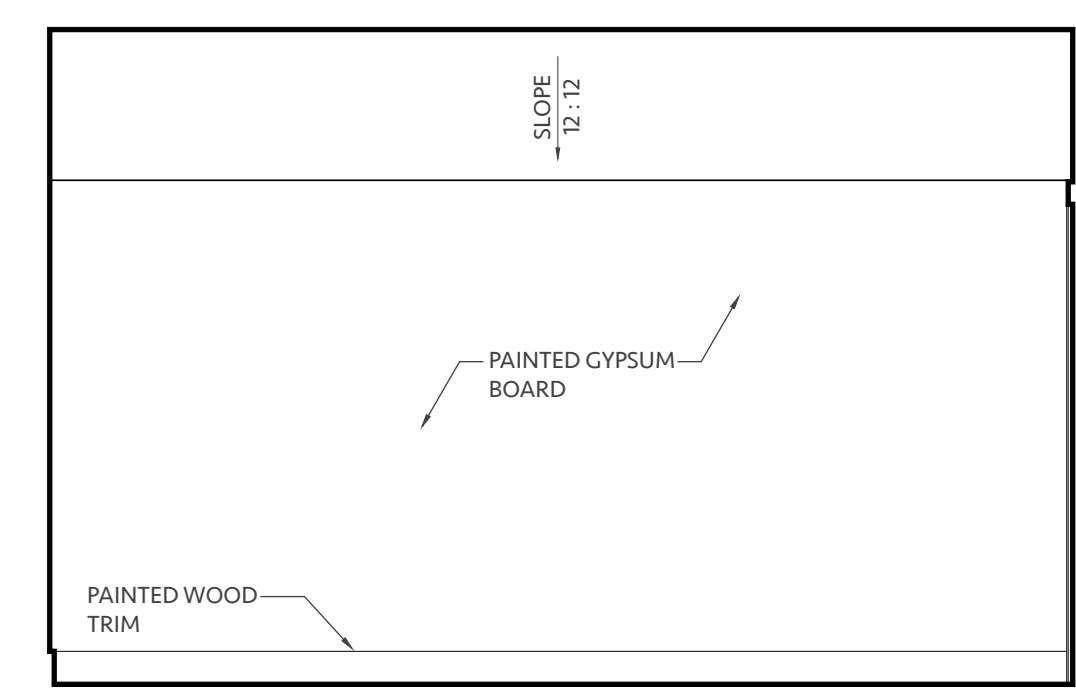

45 **BEDROOM 3**
SCALE: 3/8" = 1'-0"

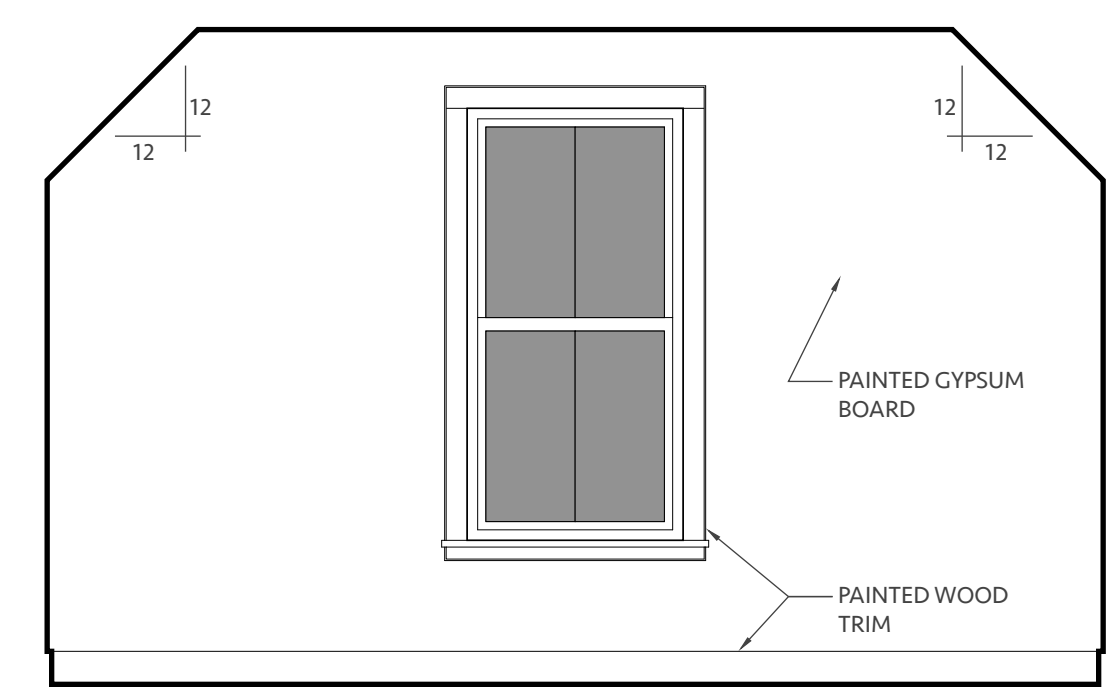

46 **BEDROOM 3**
SCALE: 3/8" = 1'-0"

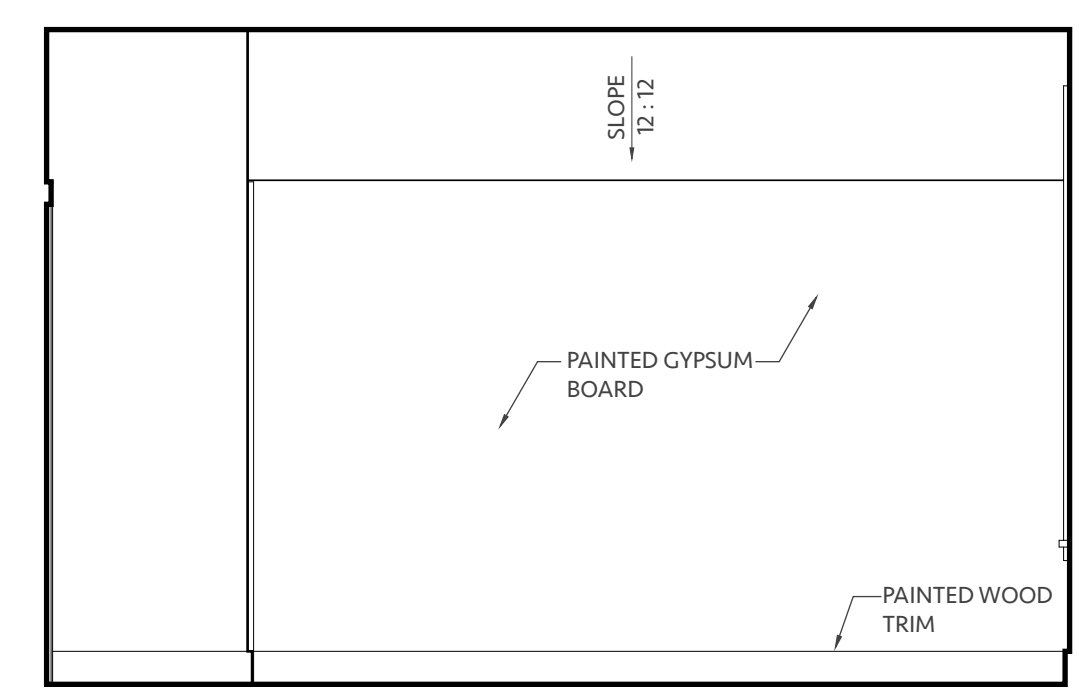

47 **BEDROOM 3**
SCALE: 3/8" = 1'-0"

SYMBOL LEGEND	
TEMPERED GLASS:	●

PERCH PLANS

NAME: ALDERNEY FARMHOUSE
 ADDRESS: LOT 1 HOLLAND ST.
 CITY: BELLVILLE, ST. TX. ZIP: 77418
 PERCH PLANS, LLC
 100 BRAZOS ST. AUSTIN, TX 78701
 P: 844-817-1999

DATE: 20 JUL. 2017
 JOB #: A-4-3
 10 of 14

A-4-3

REGISTERED ARCHITECT
 MORTY A. BROWN
 2015
 STATE OF TEXAS

© All Rights Reserved. These architectural plans are the sole property of the architect. They are to be used only for the project and location specified. No part of these plans may be reproduced or transmitted in any form, by any method, for any purpose without the prior written permission from the architect.

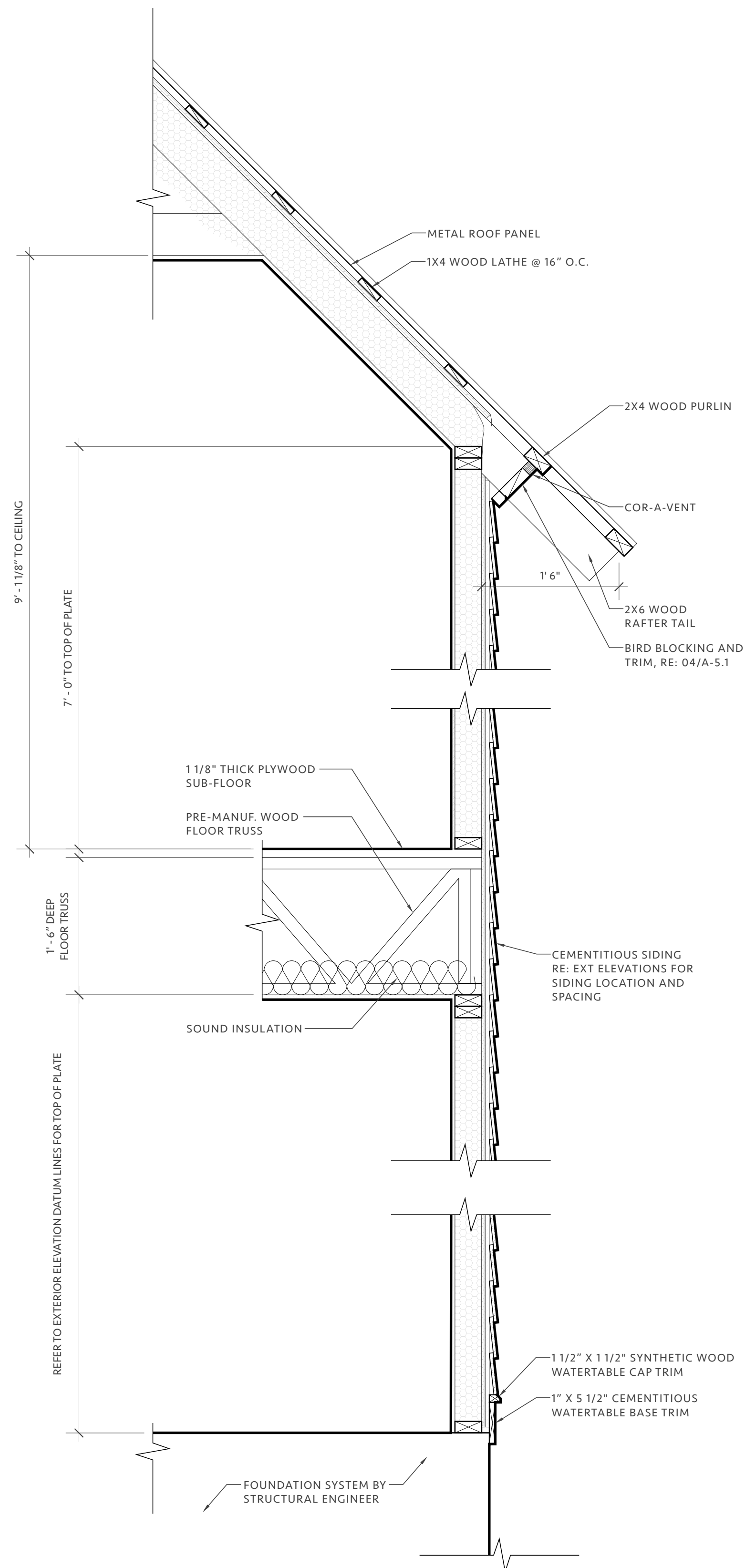

01 TYPICAL WALL SECTION
SCALE: 1" = 1'-0"

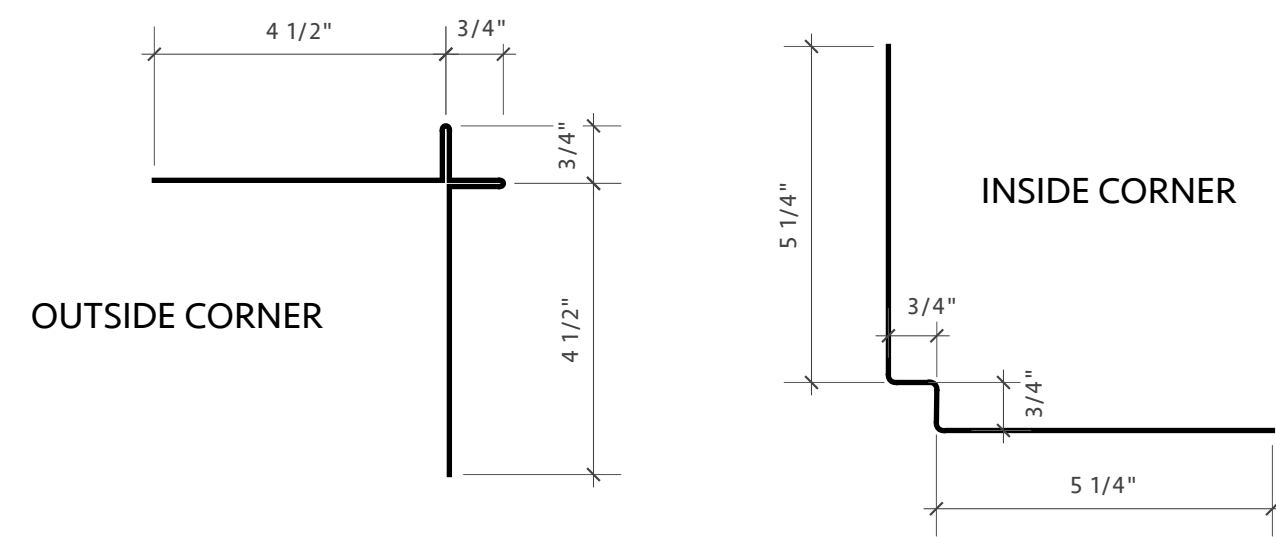

02 EXTERIOR CORNER TRIM
SCALE: 1" = 3"

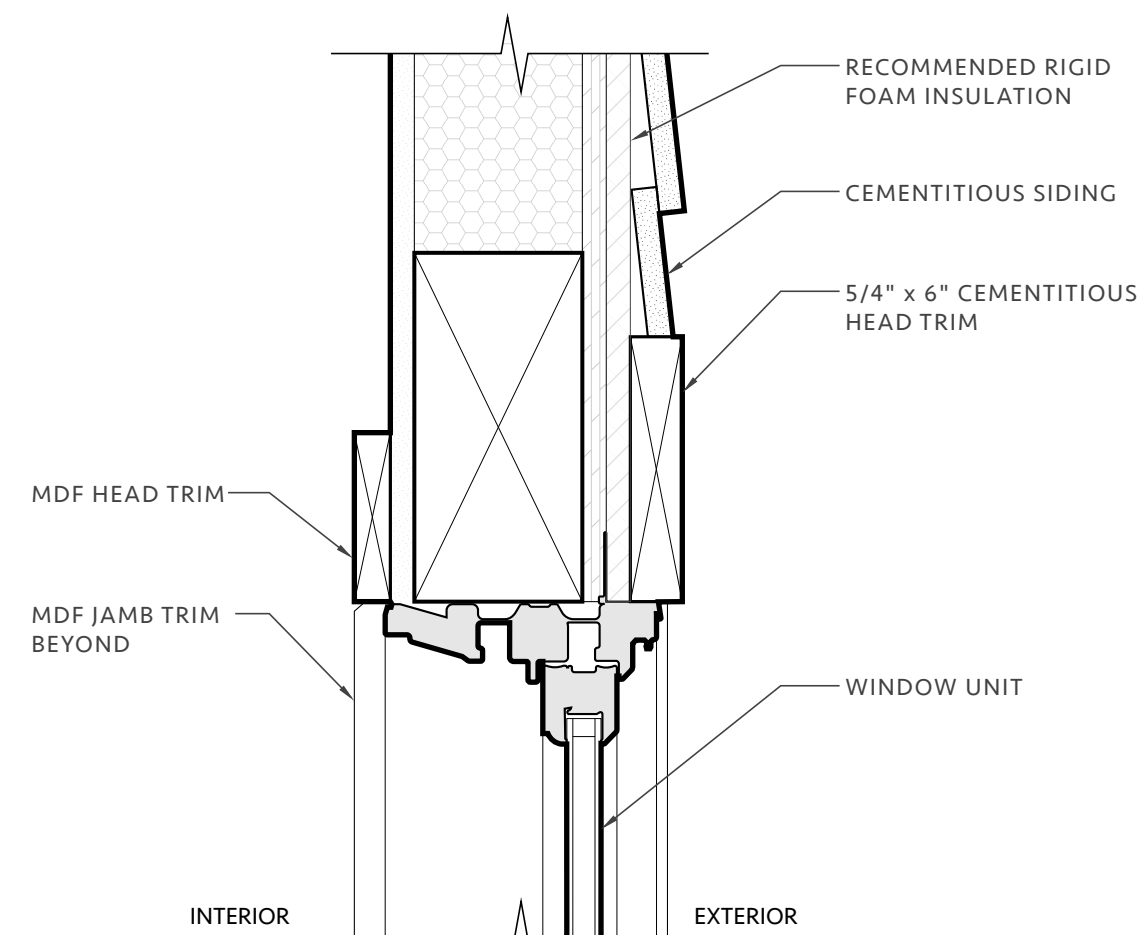

HEAD

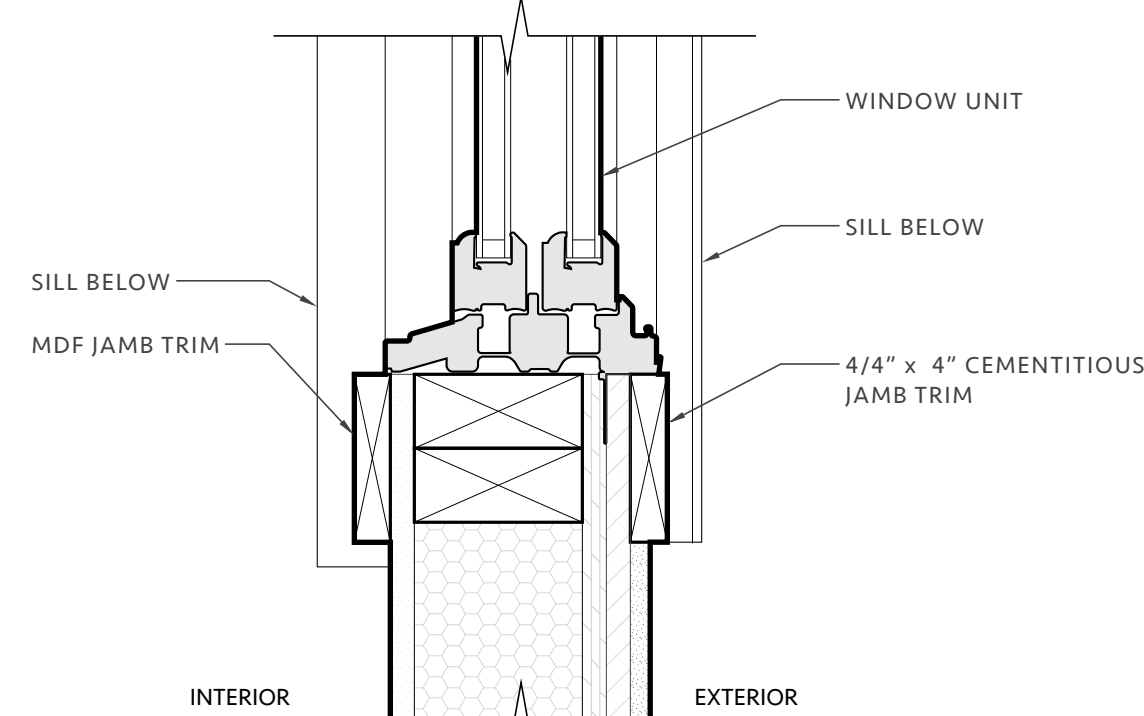

JAMB

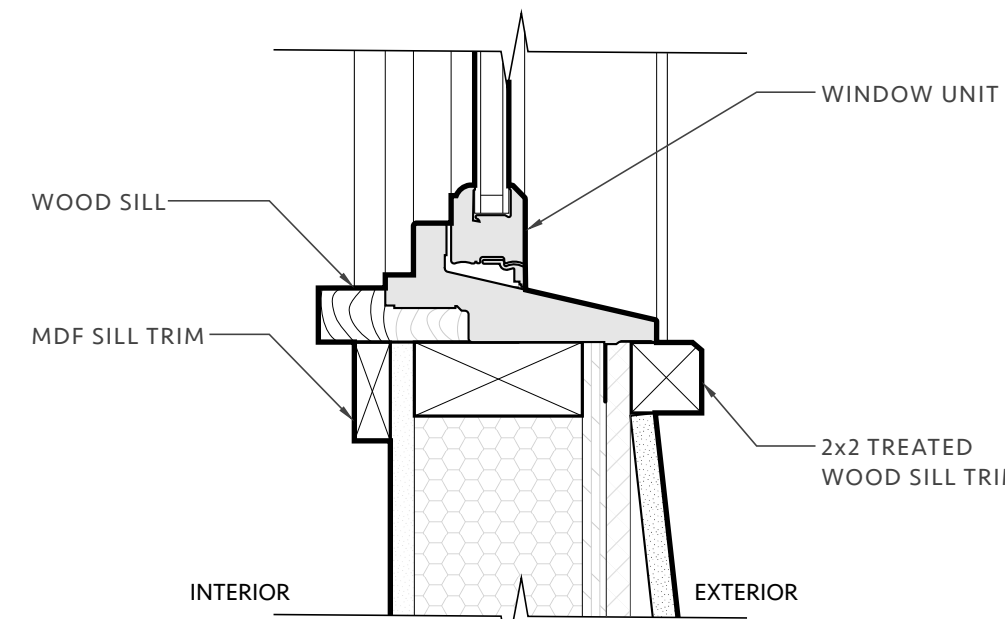

SILL

03 TYPICAL WINDOW DETAILS
SCALE: 3" = 1'-0"

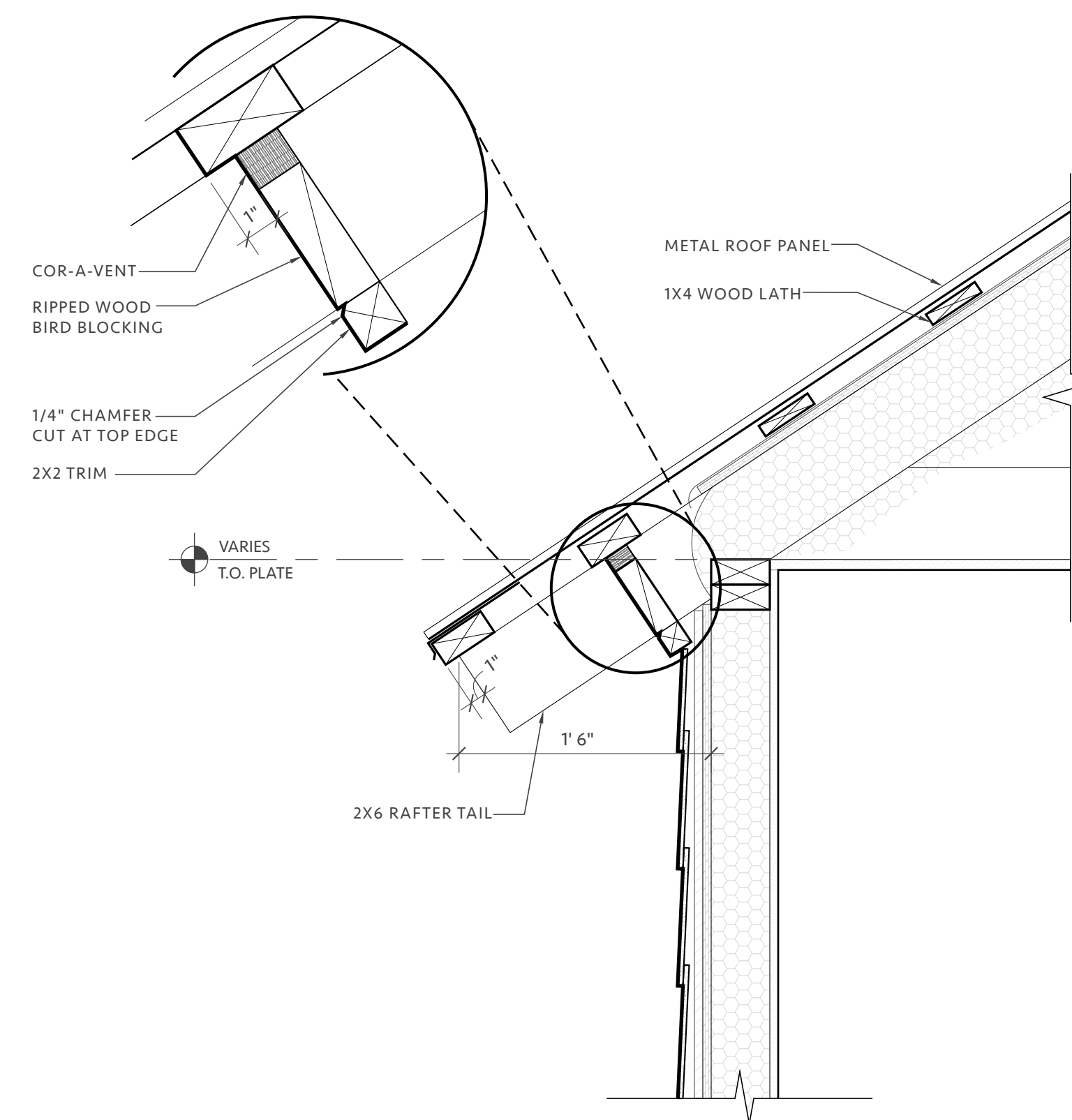

04 TYPICAL ROOF OVERHANG
SCALE: 1 1/2" = 1'-0"

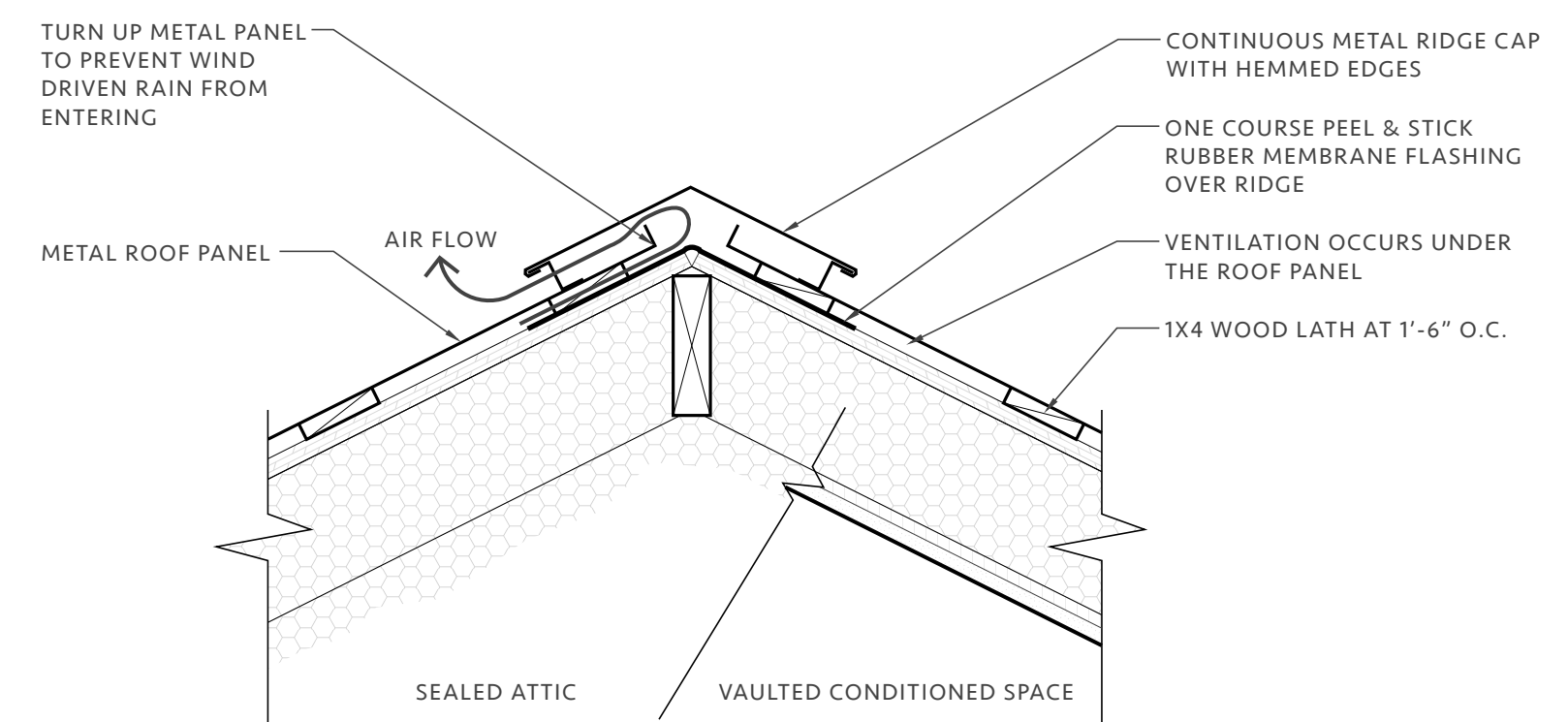

05 RIDGE VENT DETAIL
SCALE: 1 1/2" = 1'-0"

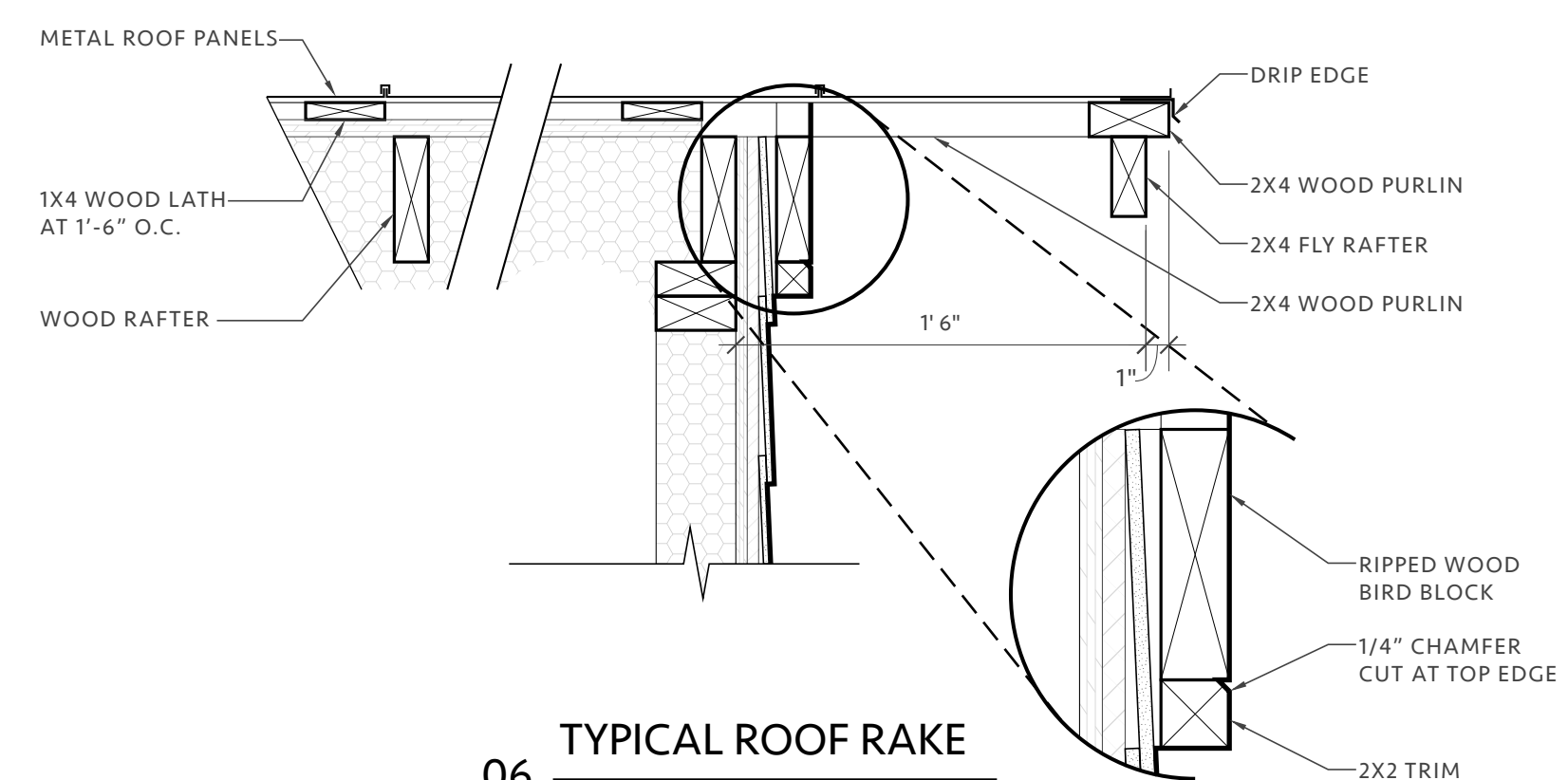

06 TYPICAL ROOF RAKE
SCALE: 1 1/2" = 1'-0"

NAME: ALDERNEY FARMHOUSE

ADDRESS: LOT 1 HOLLAND ST.

CITY: BELLVILLE, ST. TX. ZIP: 77418

PERCH PLANS, LLC

100 BRAZOS ST.

AUSTIN, TX 78701

H-844-817-1999

DATE: 20 JUL. 2017

JOB #:

A-5.1

11 of 14

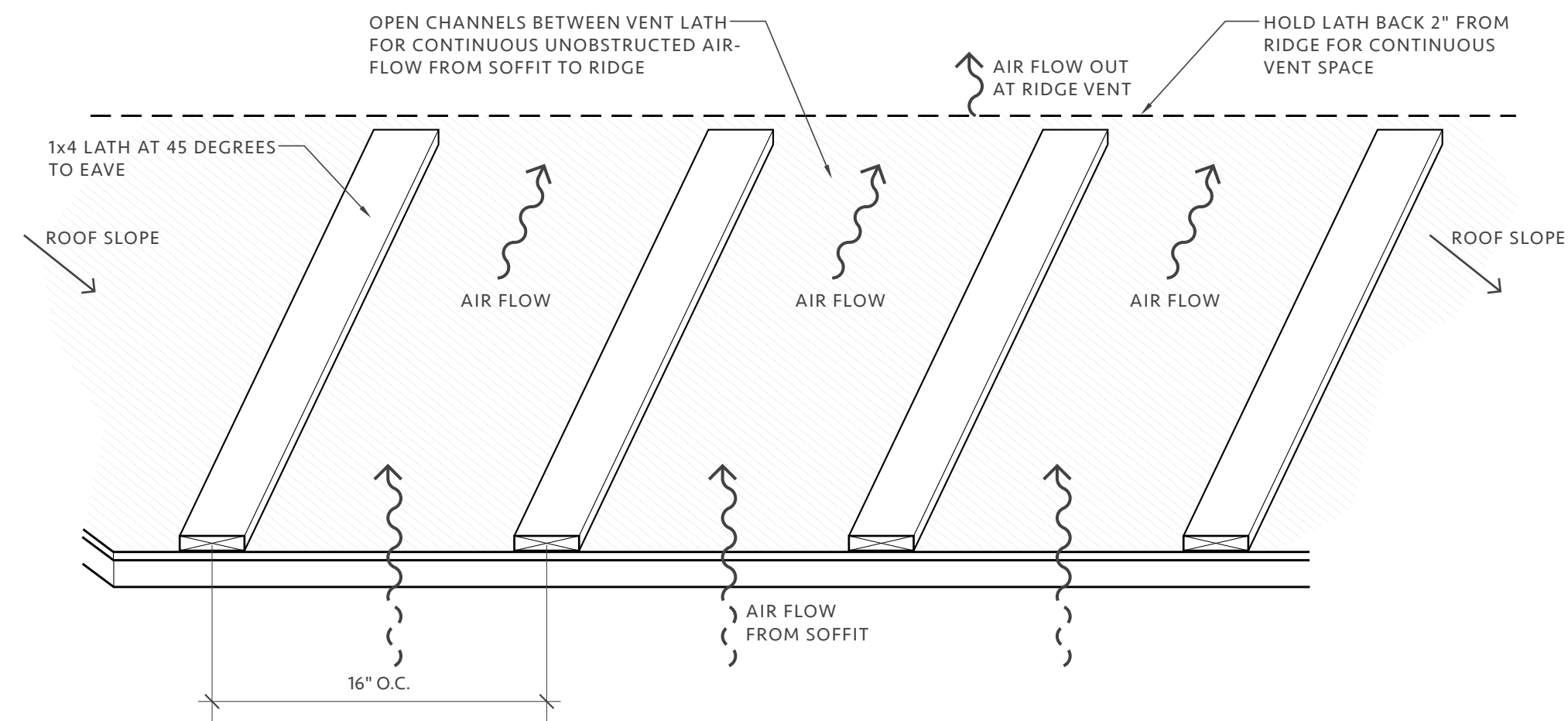

01 ROOF LATH DETAIL
SCALE: 1 1/2" = 1'-0"

NOTE: INSTALL BUILDER'S FELT AND METAL LATH AFTER OPENING ARE FULLY FLASHED

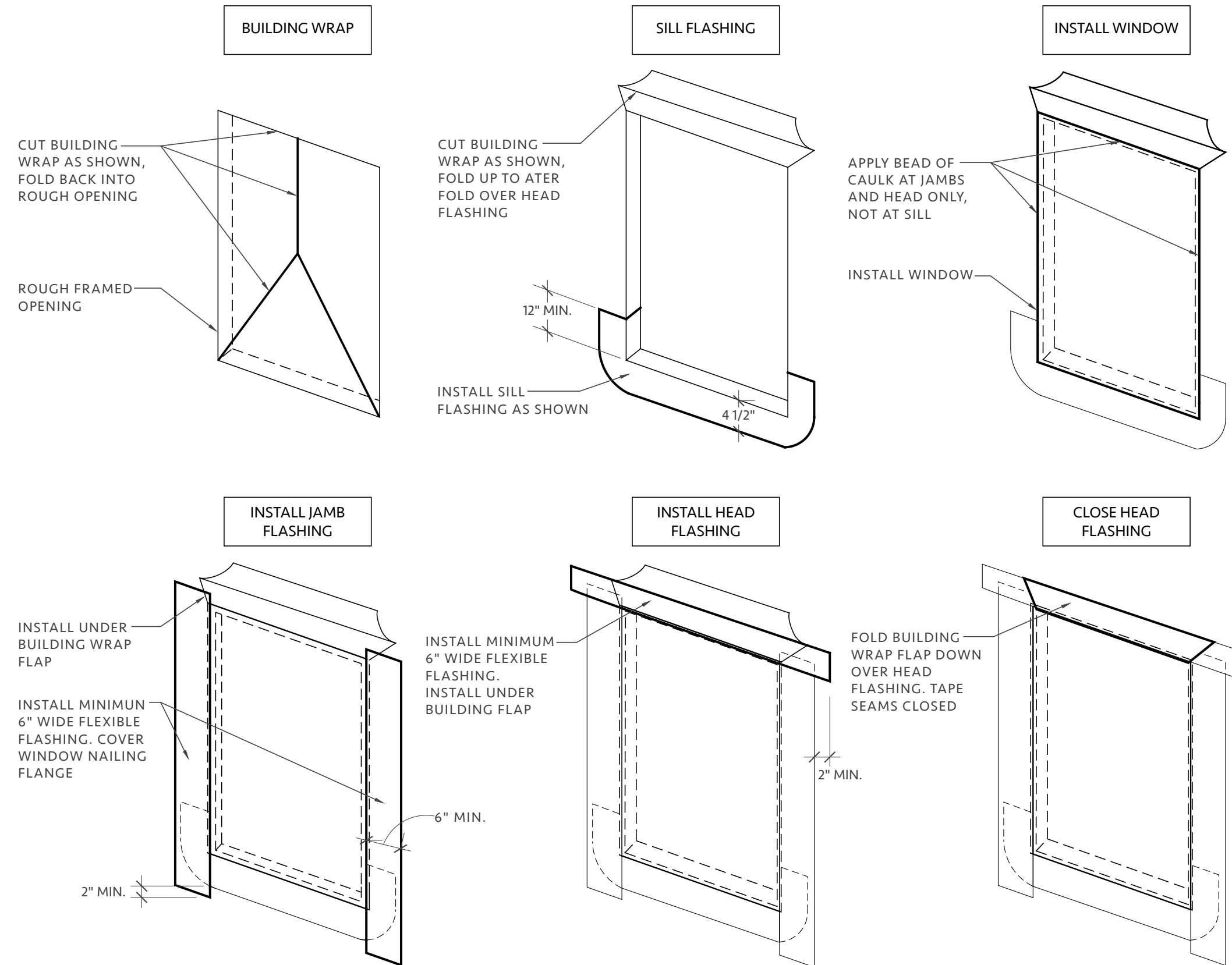

02 TYPICAL FLASHING DETAIL
SCALE: 1 1/2" = 1'-0"

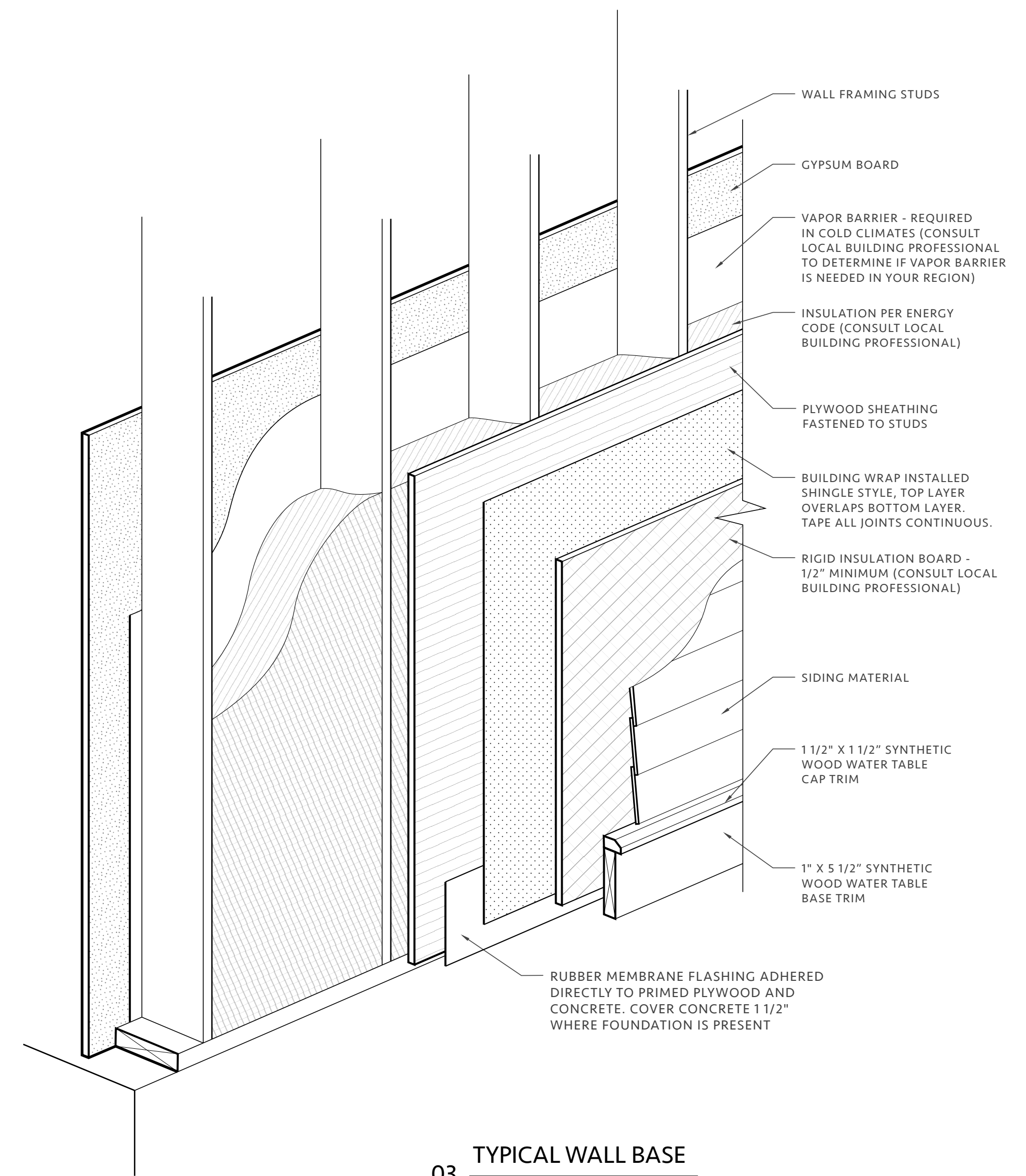

03 TYPICAL WALL BASE
SCALE: 1 1/2" = 1'-0"

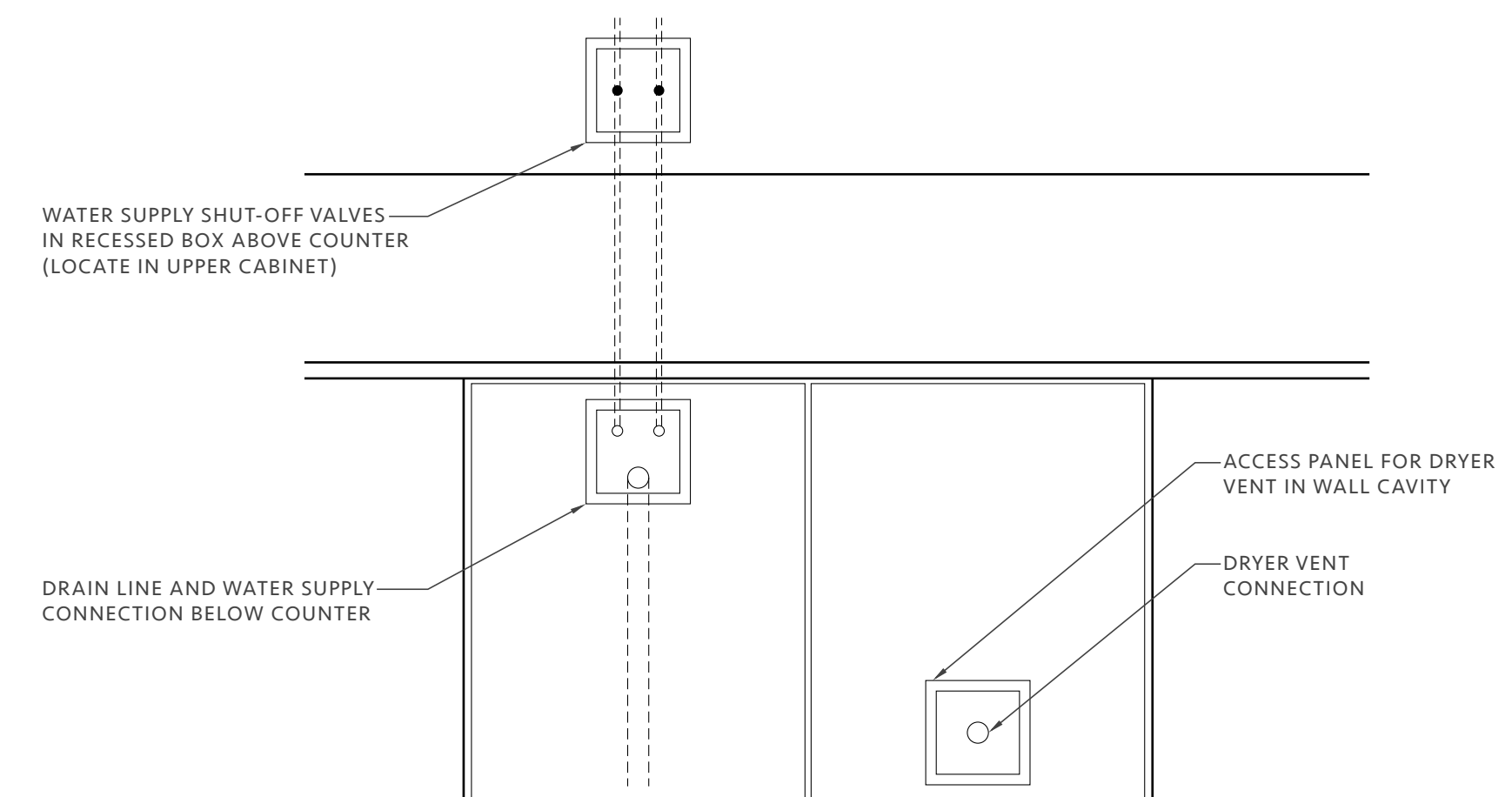

04 WASHING MACHINE/ DRYER DETAIL
SCALE: 3/4" = 1'-0"

PERCH PLANS

NAME: ALDERNEY FARMHOUSE
 ADDRESS: LOT 1 HOLLAND ST.
 CITY: BELLVILLE, ST. TX, ZIP: 77418
 PERCH PLANS, LLC
 100 BRAZOS ST.
 AUSTIN, TX 78701
 H-844-817-1999

DATE: 20 JUL. 2017
 JOB #:
 A-5-2
 12 of 14

© All Rights Reserved. These architectural plans are the sole property of the architect. They are to be used only for the project and location specified. No part of these plans may be reproduced or transmitted in any form, by any method, for any purpose without the prior written permission from PERCH PLANS.

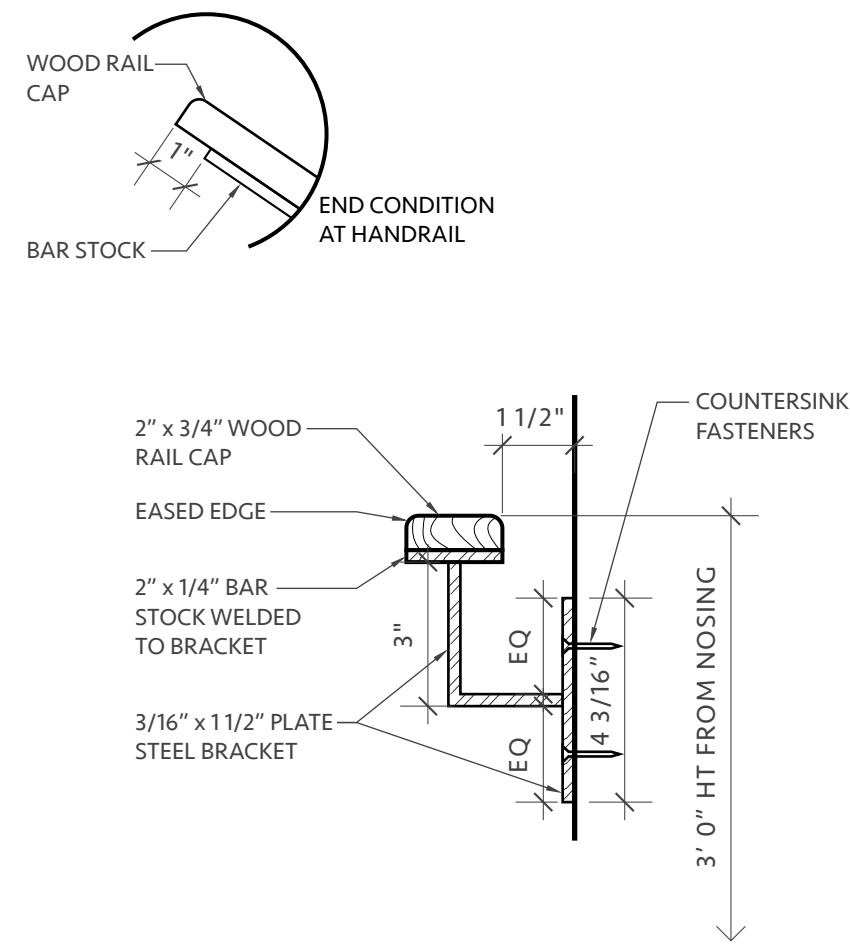

01 **HANDRAIL**
SCALE: 3" = 1'-0"

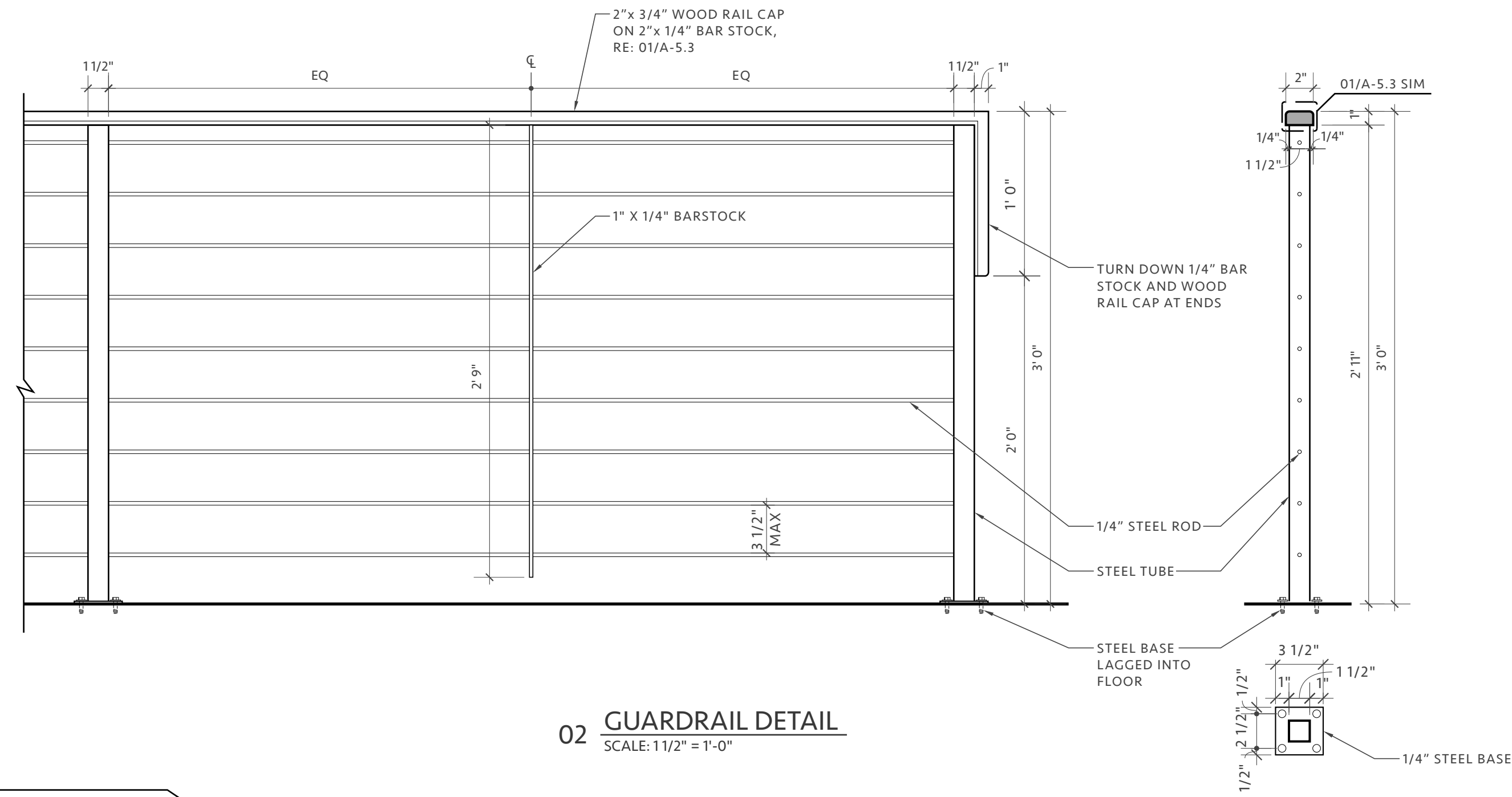

02 **GUARDRAIL DETAIL**
SCALE: 1 1/2" = 1'-0"

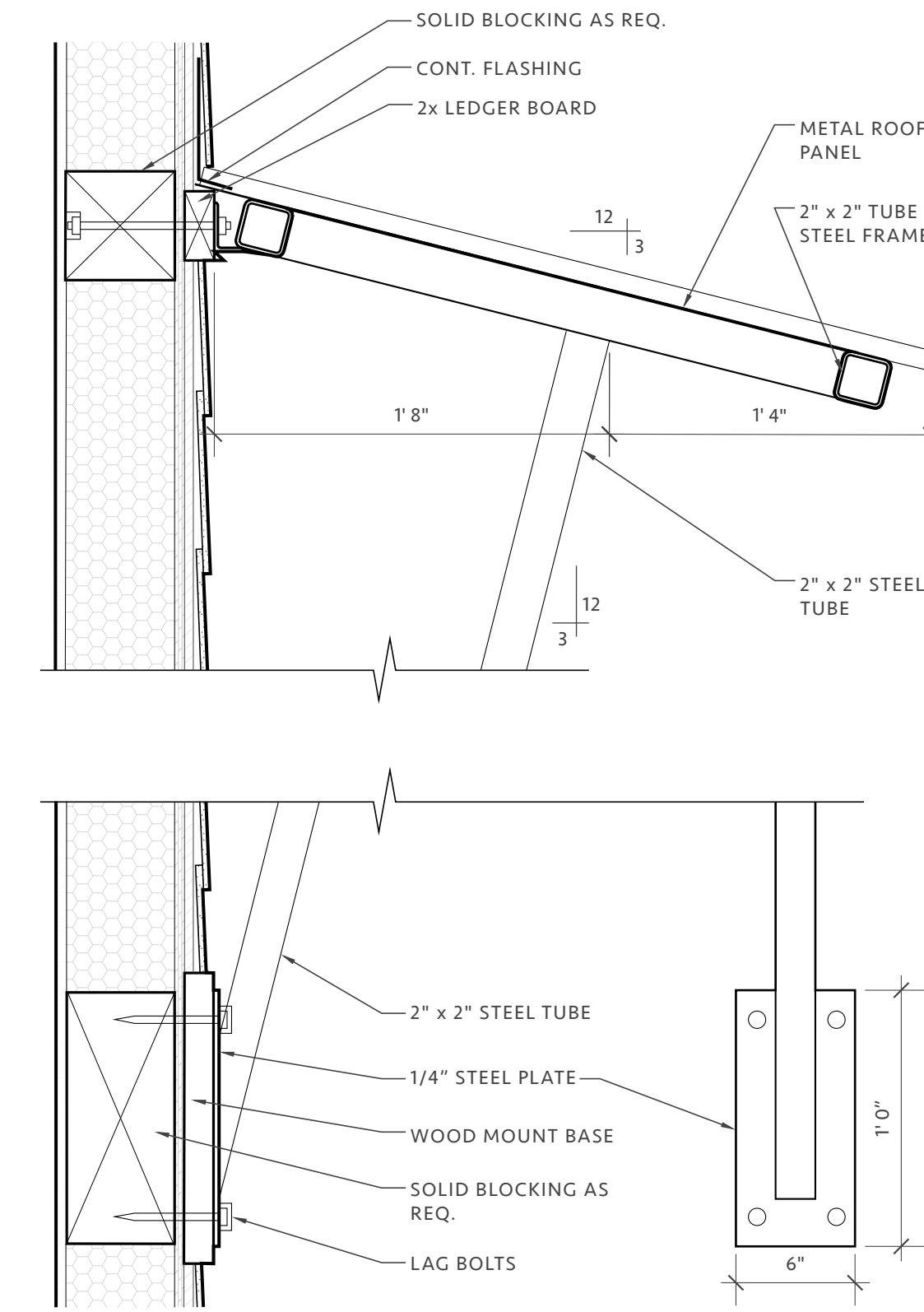

04 **STEEL AWNING DETAIL**
SCALE: 1 1/2" = 1'-0"

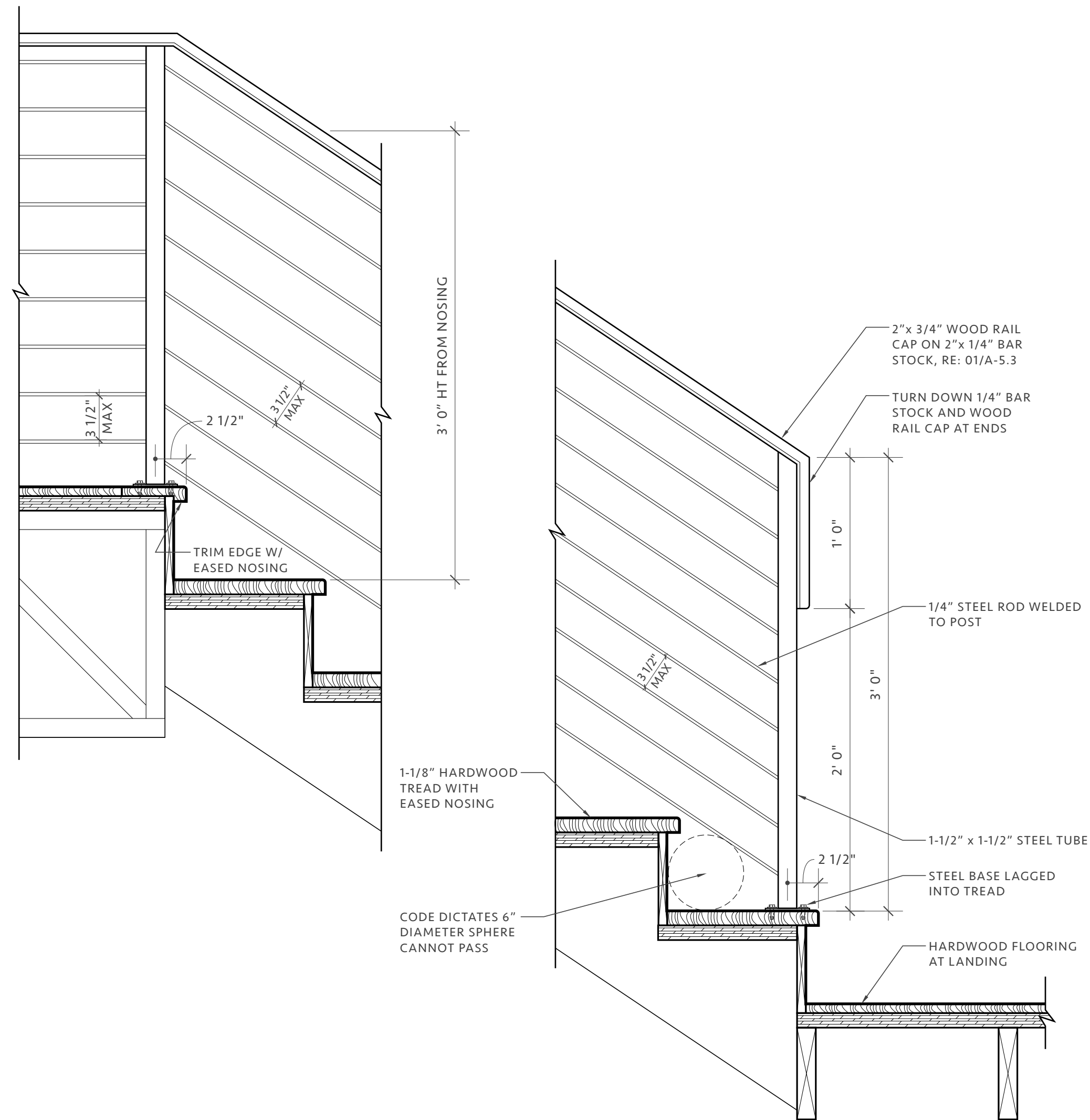

03 **GUARDRAIL AT STAIR**
SCALE: 1 1/2" = 1'-0"

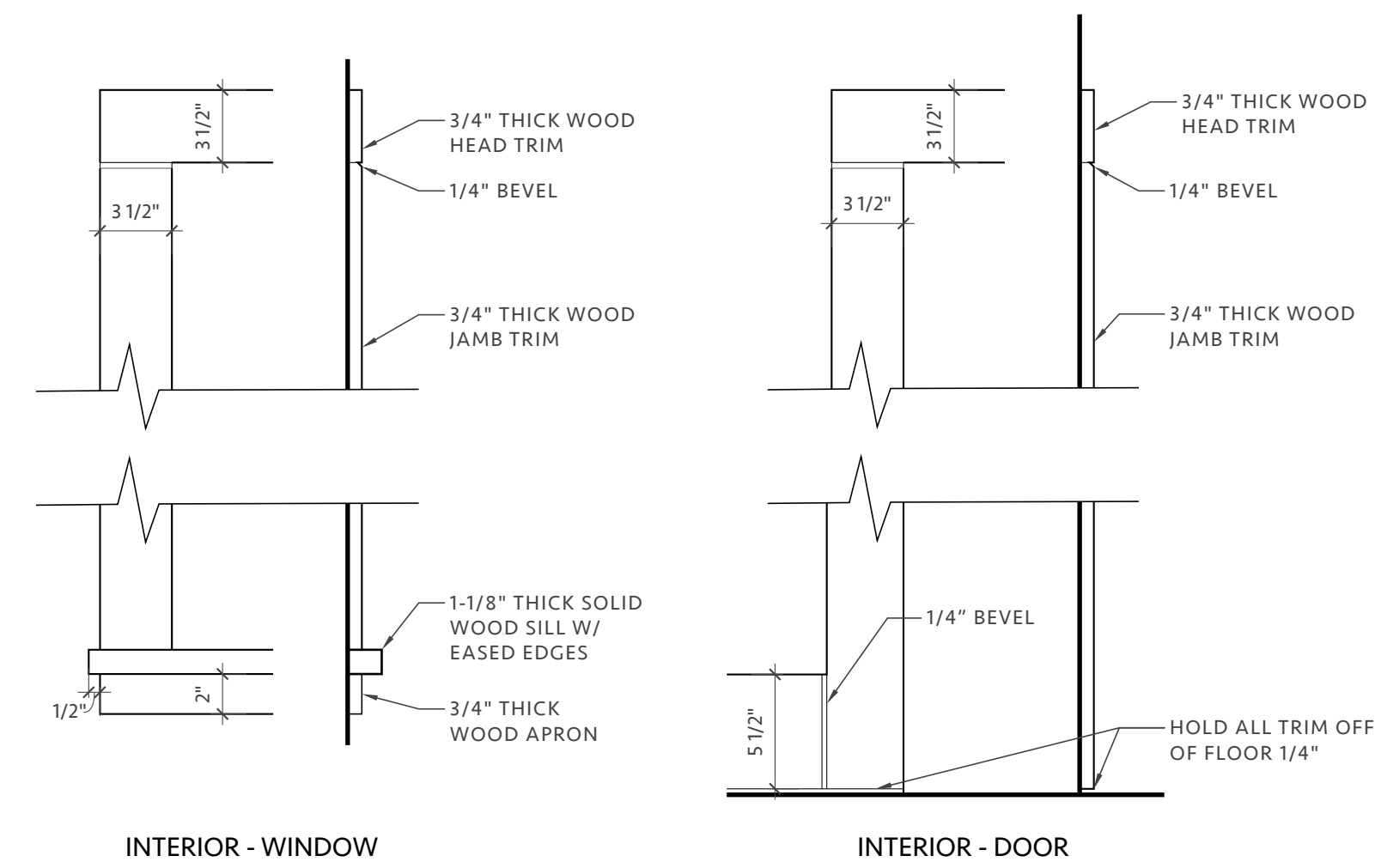

05 **TYPICAL INTERIOR TRIM CONDITIONS**
SCALE: 1 1/2" = 1'-0"

PERCH PLANS

NAME: ALDERNEY FARMHOUSE
ADDRESS: LOT 1 HOLLAND ST.
CITY: BELLVILLE, ST TX ZIP: 77418
PERCH PLANS, LLC 100 BRAZOS ST. AUSTIN, TX 78701
P: 844-817-1999

REGISTERED ARCHITECT
MONTY A. BROWN
STATE OF TEXAS

DATE: 20 JUL. 2017
JOB #:
A-5.3
13 of 14

SYMBOLS LEGEND			
⌘	SWITCH (46" A.F.F. U.N.O.)	⌘	RECESSED CAN LIGHT FIXTURE
⌘	FAN SPEED CONTROL SWITCH	⌘	FLUORESCENT FIXTURE
⌘	TIMER SWITCH	—	UNDER-COUNTER LED FIXTURE
▼	TELEPHONE/ DATA	⌘	WALL MOUNTED FIXTURE
⌘	DUPLEX RECEPTACLE (12" A.F.F. U.N.O.)	⌘	HOSE BIBB
⌘	DUPLEX RECEPTACLE MOUNTED AT X" A.F.F.	—	1/4" WATER SUPPLY LINE
⌘	WEATHER PROOF DUPLEX RECEPTACLE	⌘	THERMOSTAT
⌘	GFCI CIRCUIT OUTLET	⌘	CABLE OUTLET
⌘	240V RECEPTACLE	⌘	SMOKE/ CO DETECTOR
⌘	FLOOR RECEPTACLE (VERIFY LOCATION W/ OWNER)	⌘	VENT/ TIMER SWITCH
⌘	PUSH-BUTTON CONTROL	⌘	SHUT-OFF VALVE
⌘	SHOWER HEAD	⌘	CEILING FAN (NO LIGHT)
⌘	TUB FILLER	⌘	CEILING FAN (W/ LIGHT)
+	TEMPERATURE/PRESSURE CONTROLS		
⌘	ELECTRICAL PANEL		
⌘	SURFACE MOUNTED LIGHT FIXTURE		

- GENERAL MEP NOTES:**
1. ALL MECHANICAL, ELECTRICAL, AND PLUMBING WORK TO CONFORM TO LOCAL, STATE, AND NATIONAL CODES, WHICH TAKE PRECEDENCE OVER THESE DRAWINGS. REPORT ANY ERRORS, DISCREPANCIES, OR OMISSIONS TO THE ARCHITECT BEFORE STARTING ANY WORK.
 2. SUPPLY POWER TO ALL EQUIPMENT AND APPLIANCES AS REQUIRED PER MANUFACTURER'S RECOMMENDATIONS.
 3. NO ELECTRICAL WIRING LESS THAN NO. 12 AWG ALLOWED.
 4. ALL BATHROOM VENTS TO BE CONTROLLED BY TIMER SWITCHES.
 5. ALL ACCENT AND RECESSED LIGHT FIXTURES TO BE CAREFULLY CENTERED ON THEIR RESPECTIVE CABINETS, NICHES, ETC.
 6. CEILING FANS AT 8'-0" A.F.F. - U.N.O.
 7. OUTLETS AT KITCHEN, BATH, & EXTERIORS TO BE G.F.C.I. CIRCUIT.
 8. COORDINATE ALL SECURITY AND SOUND FREE PRE-WIRING W/ OWNER.
 9. LOCATE DOORBELL CHIME W/OWNER.

FIXTURE SCHEDULE:

L-1	Recessed Can Light Fixture
L-2	Chandelier
L-3	Pendant 1
L-4	Under-cabinet Fixture
L-5	Wall Sconce 1
L-6	Vent
L-7	Pendant 2
L-8	Ceiling Fan w/ No Light Kit
L-9	Pendant 3
L-10	Surface Mounted Ceiling Fixture 1
L-11	Surface Mounted Wall Fixture 2
L-12	Ceiling Fan w/ Light Kit
L-13	Exterior Wall Sconce
L-14	Fluorescent Light Fixture
P-1	Kitchen Sink
P-2	Toilet
P-3	Bathroom Lavatory w/Pedestal
P-4	Bathroom Lavatory
P-5	Shower Head and Controls
P-6	Shower Head/Tub Filler and Controls
P-7	Bathtub

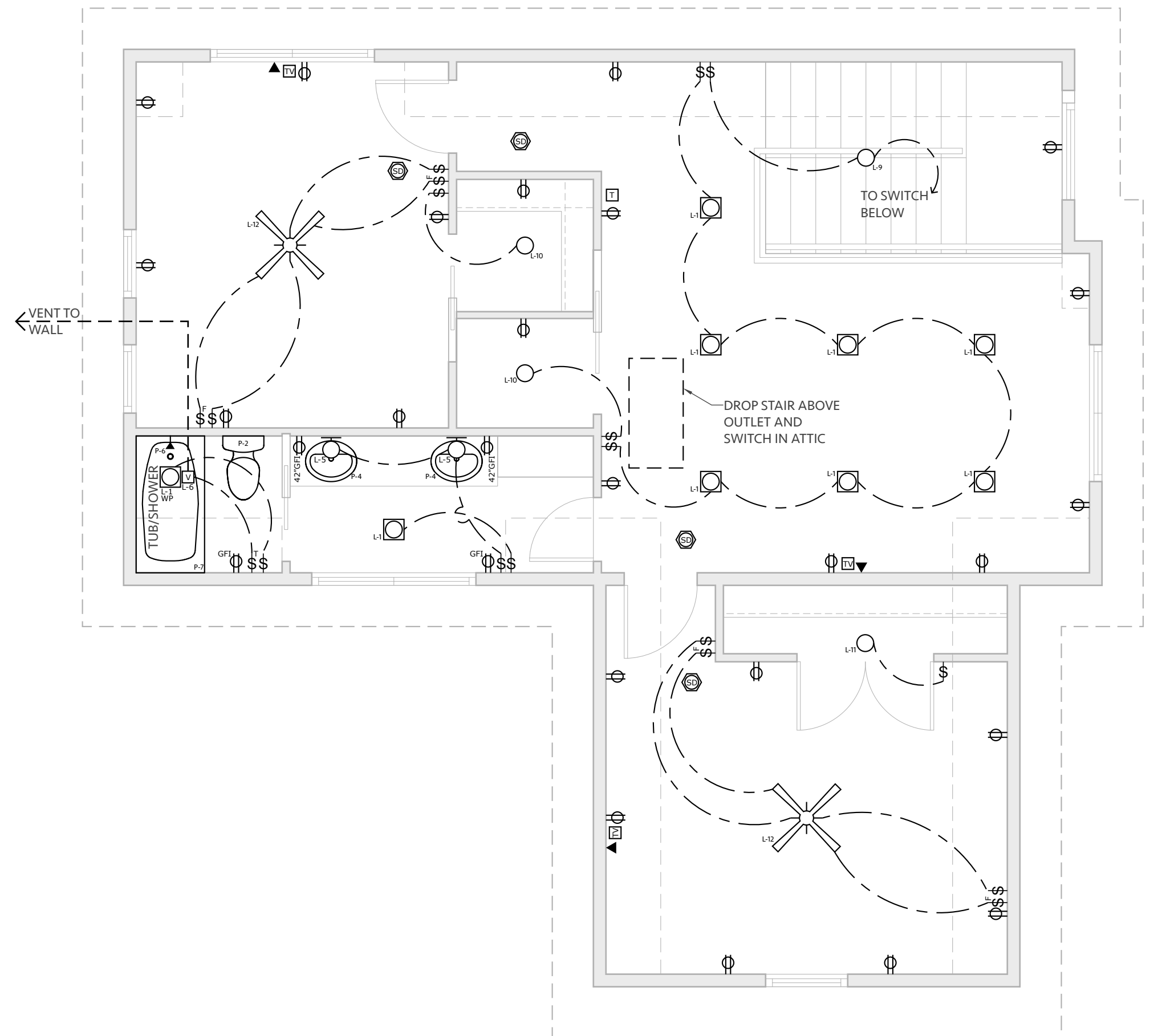

02 **MEP - SECOND FLOOR**
SCALE: 1/4" = 1'-0"

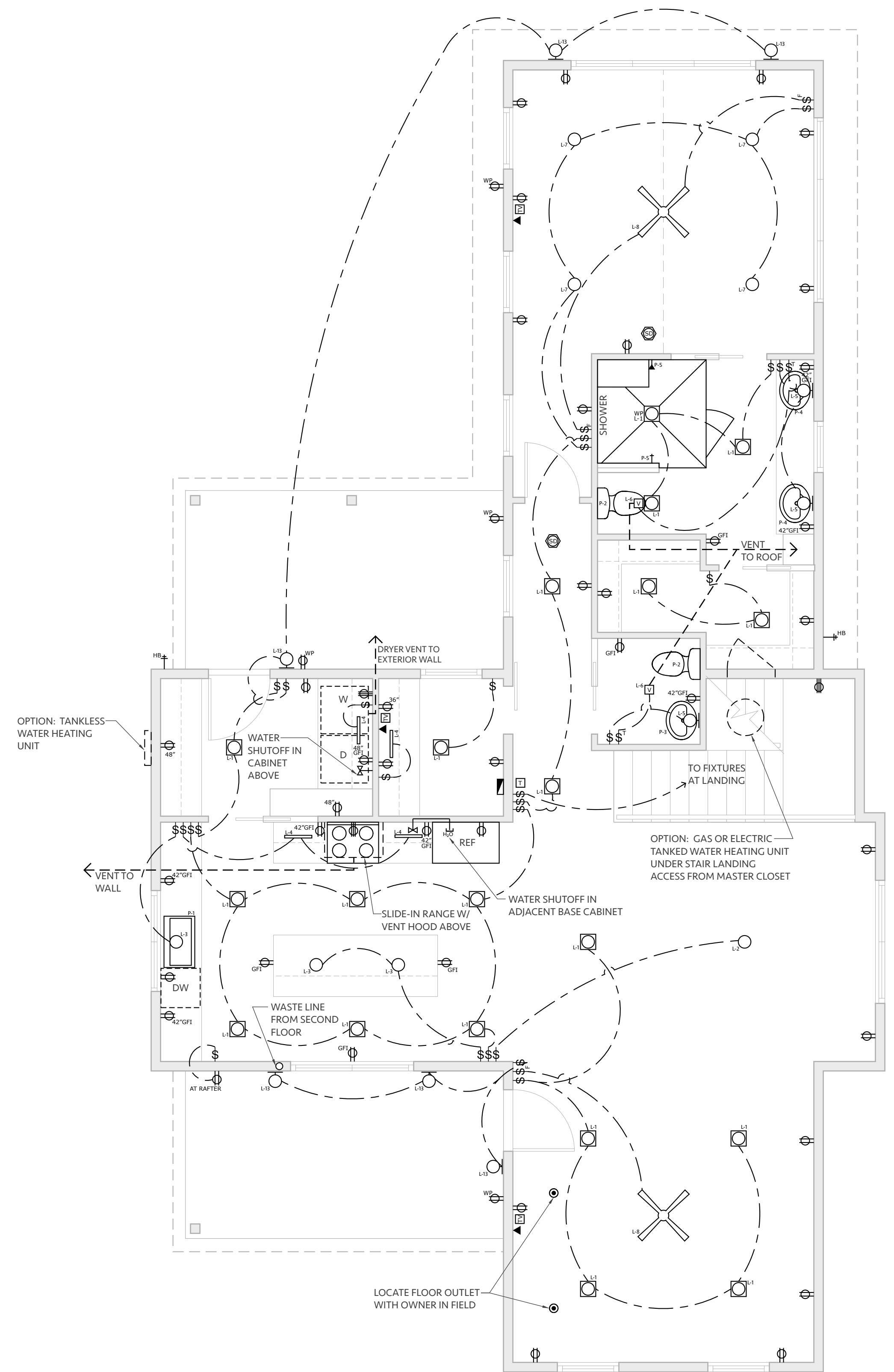

01 **MEP - FIRST FLOOR**
SCALE: 1/4" = 1'-0"

PERCH PLANS

NAME: ALDERNEY FARMHOUSE
 ADDRESS: LOT 1 HOLLAND ST.
 CITY: BELLVILLE, ST TX ZIP: 77418
 PERCH PLANS, LLC
 100 BRAZOS ST
 AUSTIN, TX 78701
 P: 512-817-1999

DATE: 20 JUL. 2017
 JOB #:
 REGISTERED ARCHITECT
 MONTY A. BROWN
 STATE OF TEXAS
 No. 10151
 EXP. 12/31/2018

MEP-1
14 of 14