



**FACTORY**  
BUILDER STORES

---

# APPLIANCES • CABINETS

Specifications for Project  
**SAMSUNG PACKAGE AND REFRIGERATOR**

Mary Garcia - Misc Cod

---

9715 Burnet Road  
Austin  
8328664920

Mary Garcia  
[mgarcia@factorybuilderstores.com](mailto:mgarcia@factorybuilderstores.com)

** REMINDER:** To ensure a smooth project it is the responsibility of the homeowner / purchaser of appliances for this project to share all the attached specifications to ensure the cabinet provider, contractor, or any other tradesperson have all the information required to complete their work accurately.

Specifications are subject to change. If any tradesperson has questions regarding the attached specifications please contact our sales associate.

# SAMSUNG PACKAGE AND REFRIGERATOR

Mary Garcia - Misc Cod

## SAMSUNG PACKAGE AND REFRIGERATOR

<i>Models</i>	<i>Pages</i>
<b>NX58H5600SS</b> Samsung Range	3-4
<b>ME16K3000AS</b> Samsung Microwave	5-6
<b>DW80M2020US</b> Samsung Dishwasher	7-8
<b>RS22T5201SR</b> Samsung Refrigeration	9-10



### Factory Builder Stores

factorybuilderstores.com

### Mary Garcia

8328664920

BT Quote **107105**

Version 2.2

Fri, Jul 24, 2020

4:15 PM CDT



steelcod.com/sp/fbst/BNQNTQUC

#### Note about page numbers:

Because the original manufacturer's documents are not altered in any way, the page numbers displayed on the page may not correspond to the page number within this package.

#### All specifications are intended for initial planning purposes only.

Manufacturers reserve the right to change specifications at any time without notice. Always consult the installation instructions found on the manufacturer's website or included with the appliances before installation.

# NX58H5600SS

5.8 cu. ft. Freestanding Gas Range with Convection

## Features

- 5 Gas Burners
  - Right Front: 17K BTU
  - Left Front: 15K BTU
  - Right Rear: 5K BTU
  - Left Rear: 9.5K BTU
  - Center: 9.5K BTU (Oval with Griddle)
- Large Oven Capacity – 5.8 cu. ft.
- Cast Iron 3 Piece Grates
- Griddle
- Convection Oven
- Storage Drawer
- Grate Indicator Marks

## Convenience

- Auto Oven Light
- Auto Shut-Off Option
- Proofing
- Sabbath Mode
- Delay Start
- Child Safety Lock
- Self Clean
- 4 Easy Cook Presets
- 2 Chrome Oven Racks



Versatile Cooktop



Convection Oven

## Available Color



Stainless Steel

## Signature Features

### CONVECTION OVEN

- The convection fan system is great for baking and broiling because heat is distributed thoroughly and food cooks evenly. Enjoy faster results each time.

### GRIDDLE

- Cook a variety of breakfast foods or grilled sandwiches at once on the removable stovetop griddle.

### LARGE CAPACITY

- Our extra-spacious 5.8 cu. ft. large-capacity oven easily handles turkey roasters and large baking sheets.

### GRATE INDICATOR MARKS

- Indicator marks located on the grates allow cookware to be ideally placed for precise cooking.



Ranked **“Highest in Customer Satisfaction with Ranges, Cooktops and Ovens.”**\*

—J.D. Power

**SAMSUNG**

# NX58H5600SS

5.8 cu. ft. Freestanding Gas Range with Convection

## Installing Your Range

\*30" minimum clearance between the top of the cooking surface and the bottom of an unprotected wood or metal cabinet; or 24" minimum when the bottom of the wood or metal cabinet is protected by not less than 1/4" flame retardant millboard covered with not less than no.28 MSG sheet steel, 0.015" stainless steel, 0.024" aluminum or 0.020" copper.

\*\*15" minimum between the countertop and the adjacent cabinet bottom.

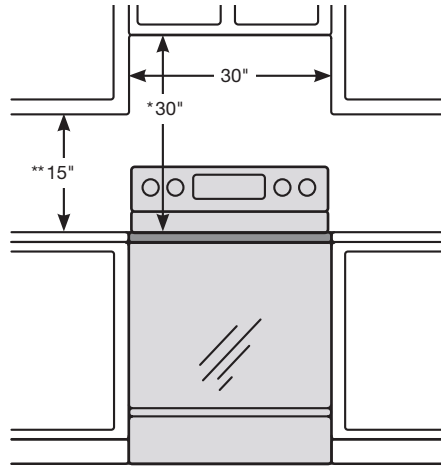

**IMPORTANT:** To eliminate the risk of burns or fire caused by reaching over heated surface units, cabinet storage space located above the surface units should be avoided. If cabinet storage is to be provided, the risk can be reduced by installing a range hood that projects horizontally a minimum of 5" beyond the bottom of the cabinets.

## Dimensions

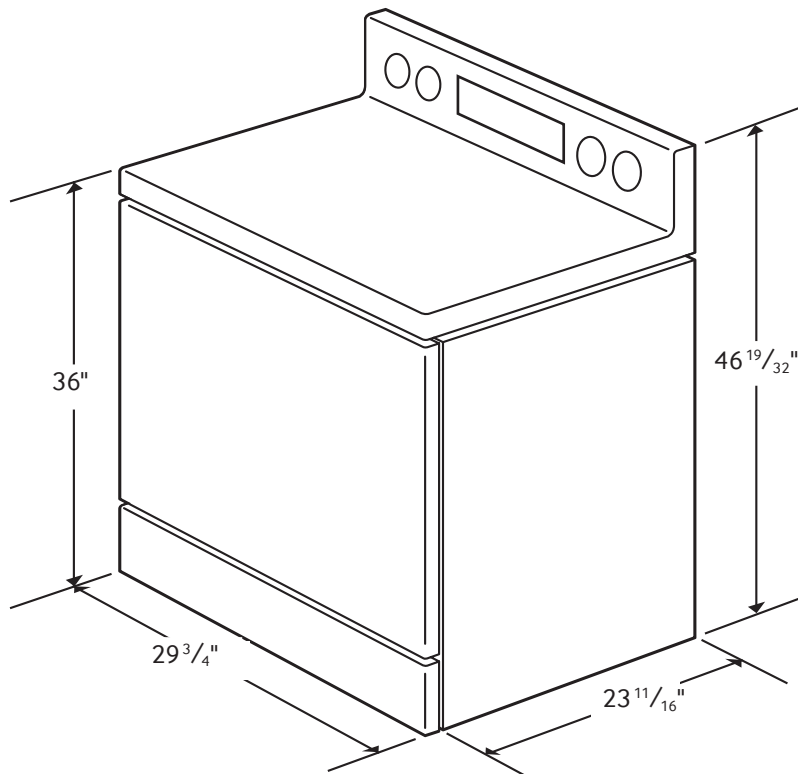

### Total Power (BTU)

56,000 BTU

### Power Source

120 V/60 Hz

### Black Enamel 5 Burner Cooktop

- Right Front: 17000 BTU
- Left Front: 15000 BTU
- Right Rear: 5000 BTU
- Left Rear: 9500 BTU
- Center Rear: 9500 BTU (Oval with Cast Iron Griddle)

### Oven

- Bake: 150°F - 550°F
- Convection Bake: 150°F - 550°F
- Bake Burner: 18000 BTU
- Broil Burner: 13500 BTU
- Convection Roast: 150°F - 550°F
- Proofing
- Sabbath Mode

### Storage Drawer

Capacity: 0.7 cu. ft.

### Warranty

One (1) Year All Parts and Labor

Five (5) Years Gas Cooktop

### Product Dimensions & Weight (WxHxD)

Actual Oven Dimensions:

25" x 19" x 21 1/8"

Outside Net Dimensions:

29 3/4" x 46 19/32" x 23 11/16"

Weight: 200 lbs.

### Shipping Dimensions & Weight (WxHxD)

Dimensions:

32 7/8" x 50 9/16" x 30 1/8"

Weight: 216 lbs.

Color

Stainless Steel

Model #

NX58H5600SS

UPC Code

887276977423

**SAMSUNG**

\*Samsung received the highest numerical score for ranges, cooktops and ovens in the proprietary J.D. Power 2014 Kitchen Appliance Study<sup>SM</sup>. Study based on 15,380 total responses measuring 17 ranges, cooktops and oven brands and measures opinions of consumers about their new appliance purchased in the past 24 months. Proprietary study results are based on experiences and perceptions of consumers surveyed in January-March 2014. Your experiences may vary. Visitjdpower.com.

Actual color may vary. Design, specifications, and color availability are subject to change without notice. Non-metric weights and measurements are approximate.

©2014 Samsung Electronics America, Inc. 85 Challenger Road, Ridgefield Park, NJ 07660. Tel: 800-SAMSUNG. samsung.com. Samsung is a registered trademark of Samsung Electronics Co. Ltd.

# ME16K3000AS

1.6 cu. ft. OTR Microwave

## Features

- 1.6 cu. ft. Oven Capacity
- 2-Speed/300 CFM Ventilation System
- LED Display
- Cooking Presets
- Eco Mode
- Microwave Distribution System: Turntable

## Convenience

- Interior Light: Incandescent (1)
- Cooktop Lighting: High/Low/Off
- Vent Fan Control: On/Off



2-Speed/300 CFM Ventilation System



LED Display

## Available Colors



Stainless Steel  
(shown)



White



Black

## Signature Features

### 1.6 CU. FT. CAPACITY

- Accommodates a variety of snacks and meals.
- Enough room to accommodate everyday meals.

### 2-SPEED/300 CFM VENTILATION SYSTEM

- Powerful ventilation system that eliminates steam, fumes, and odor from the kitchen.
- Quiet system clears the air with 300 cubic feet per minute of turbo ventilation.

### LED DISPLAY

- Striking ice blue LED display provides a stylish accent to enhance any kitchen interior.
- Time and setting are clearly visible for greater cooking convenience.

**SAMSUNG**

# ME16K3000AS

1.6 cu. ft. OTR Microwave

## Installing Your Microwave

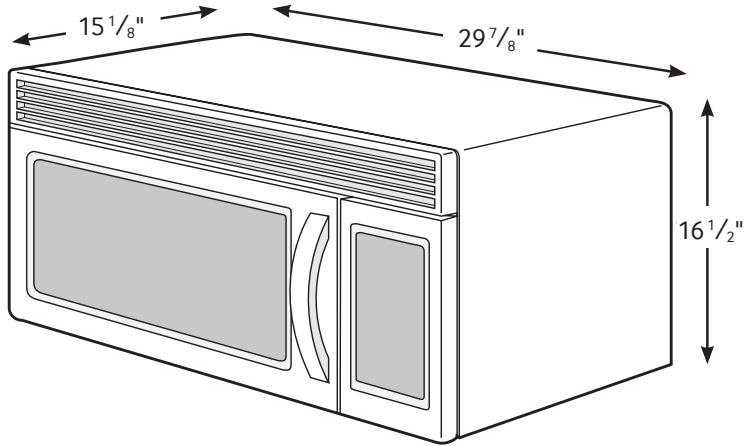

This microwave oven is designed for adaptation to the following three types of ventilation:

- A. Outside Top Exhaust (Vertical Duct)
- B. Recirculating (Non-Vented Ductless)
- C. Outside Back Exhaust (Horizontal Duct)

- The space between the cabinets must be 30" wide and free of obstructions.
- This microwave oven is for installation over ranges up to 36" wide.
- The microwave must be level. Use a level to make sure the cabinet bottom is level. If the cabinets have a front overhang only, with no back or side frame, install the mounting plate down the same distance as the front overhang depth. This will keep the microwave level.

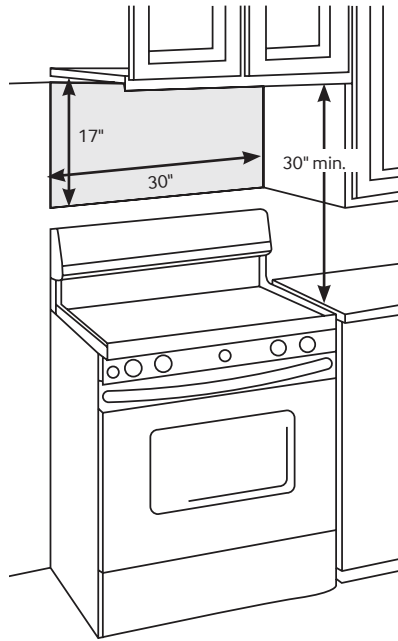

## Specifications

- Oven Cavity: 1.6 cu. ft.
- Power Output: 1000 W
- Power Consumption: 1580 W/13.5 A
- Power Source: 120 V/60 Hz
- Control Method: Digital (Membrane Touch)
- Display: LED
- Cooking Control: 10 Power Levels Including Defrost
- Cooking Timer: Digital, up to 99 Minutes, 99 Seconds
- Microwave Distribution System: Turntable
- Glass Turntable Diameter: 11 8/16"
- Vent Fan: 300 CFM
- Vent Fan Control: On/Off
- Cooktop Lighting: High/Low/Off

## Warranty

One (1) Year All Parts and Labor  
Ten (10) Years Parts on Magnetron

## Product Dimensions & Weight (WxHxD)

Cavity Dimensions:  
19<sup>5</sup>/<sub>16</sub>" x 9<sup>5</sup>/<sub>8</sub>" x 14<sup>3</sup>/<sub>8</sub>"

Outside Net Dimensions:  
29<sup>7</sup>/<sub>8</sub>" x 16<sup>1</sup>/<sub>2</sub>" x 15<sup>1</sup>/<sub>8</sub>"

Weight: 44.2 lbs. (Stainless)  
43.3 lbs. (White, Black)

## Shipping Dimensions & Weight (WxHxD)

Dimensions:  
33<sup>3</sup>/<sub>8</sub>" x 19<sup>15</sup>/<sub>16</sub>" x 19<sup>7</sup>/<sub>16</sub>"

Weight: 51.8 lbs. (Stainless)  
50.8 lbs. (White, Black)

Color	Model #	UPC Code
Stainless Steel	ME16K3000AS	887276120287
White	ME16K3000AW	887276120300
Black	ME16K3000AB	887276120270

FOR EASIER INSTALLATION AND PERSONAL SAFETY, WE RECOMMEND THAT TWO PEOPLE INSTALL THIS MICROWAVE OVEN.

IMPORTANT: Do not grip or use handle during installation.

NOTE: If your cabinet is metal, use the nylon grommet around the power cord hole to prevent cutting of the cord.

NOTE: We recommend using filler blocks if the cabinet front hangs below the cabinet bottom shelf.

IMPORTANT: If filler blocks are not used, case damage may occur from overtightening screws.

NOTE: When mounting the microwave oven, thread power cord through hole in bottom of top cabinet.

Do not pinch cord or lift oven by pulling cord.

**SAMSUNG**

Actual color may vary. Design, specifications, and color availability are subject to change without notice.  
Non-metric weights and measurements are approximate.

©2017 Samsung Electronics America, Inc. 85 Challenger Road, Ridgefield Park, NJ 07660. Tel: 800-SAMSUNG. [samsung.com](http://samsung.com).  
Samsung is a registered trademark of Samsung Electronics Co. Ltd.

# DW80M2020US

SAMSUNG

## Samsung Dishwasher



### Signature Features

#### Stainless Steel Interior Door

- The interior door is covered with stainless steel that's more durable, hygienic, and quieter.\*

#### Height-Adjustable Upper Rack

- Easily fit dish ware of various shapes and sizes.

#### Digital Water Leakage Sensor

- Identifies leaks as small as 2.4 ounces and shuts itself off before water can escape.

\*Than similar competitors models.

### Available Color



Stainless Steel



Stainless Steel Interior Door



Height-Adjustable Upper Rack

### Features

- Fully Integrated Top Control
- Advanced Wash System
- ENERGY STAR® rated: 249 kWh/Year
- Touch Control
- 4 Wash Cycles
- 5 Options
- 14 Place Settings

### Convenience

- Child Lock
- Delay Start
- Height-Adjustable Upper Rack

# DW80M2020US

# SAMSUNG

## Samsung Dishwasher

### Installation Specifications

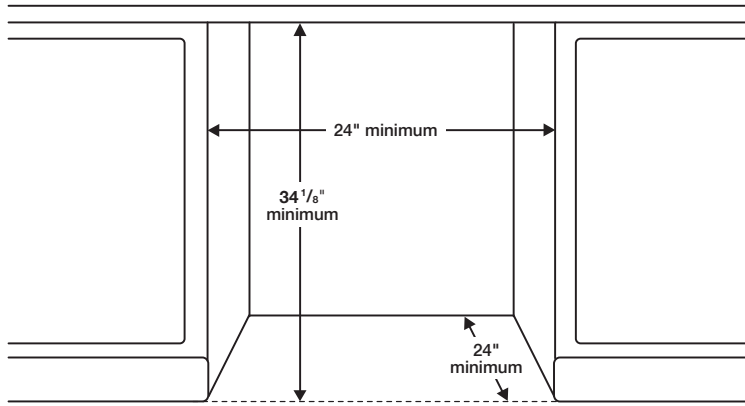

### Features

- 4 Wash Cycles: Auto, Normal, Heavy, Express 60
- 5 Options: Hi-Temp Wash, Sanitize (Anti-bacterial – NSF), Delay Start, Child Lock, Heated Dry

### Convenience

- Child Lock
- Digital Water Leakage Sensor
- Height-Adjustable Upper Rack
- Polypropylene Racking
- Upper Rack: 2 Cup Shelves
- Silverware Basket

### Warranty

One (1) Year All Parts and Labor

Five (5) Year Limited on Printed Circuit Board and Interior Nylon Racks

### Product Dimensions & Weight (WxHxD)

Dimensions:

23<sup>3</sup>/<sub>4</sub>" x 33<sup>3</sup>/<sub>4</sub>" x 24<sup>5</sup>/<sub>8</sub>"

Weight: 62.9 lbs.

### Dimensions

Side View

Rear View

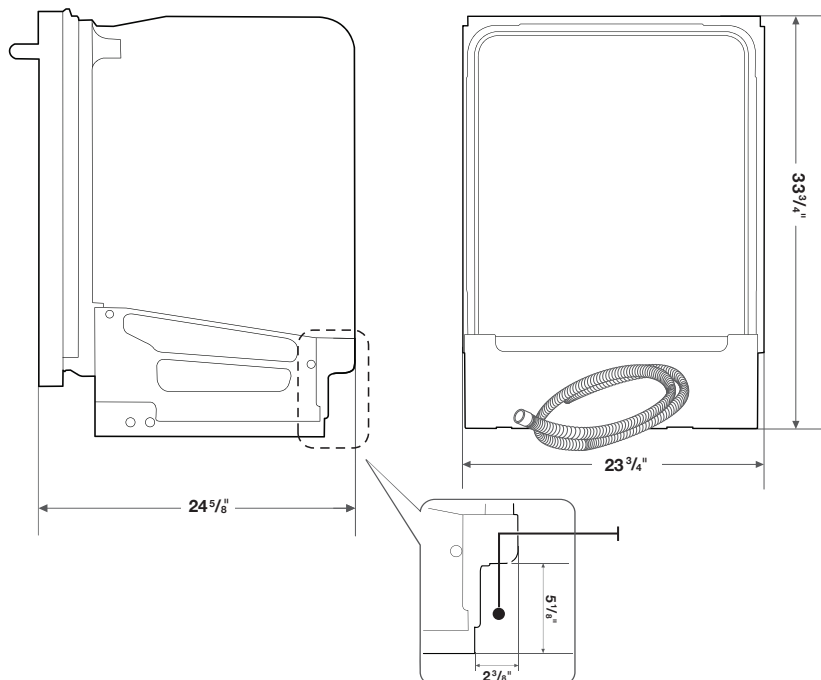

### Shipping Dimensions & Weight (WxHxD)

Dimensions:

26<sup>1</sup>/<sub>2</sub>" x 35" x 29<sup>1</sup>/<sub>2</sub>"

Weight: 78 lbs.

### Color

Stainless Steel

### Model #

DW80M2020US

### UPC Code

887276196381



# RS22T5201SR

SAMSUNG

## 22 cu. ft. Side-By-Side Counter Depth Refrigerator



### Signature Features

#### Built-in Look with Counter Depth

Built-in look, for a seamless fit. The smooth and streamlined exterior design features beautiful flat doors, a minimal display dispenser, and easy to open recessed handles that blend beautifully into your cabinetry, adding function and style to your kitchen.

#### Fingerprint Resistant Finish

A finish that withstands everyday smudges, so you spend less time cleaning.

#### All-Around Cooling

Multi-air vents keep every item on every shelf evenly cooled.

### Available Colors



Fingerprint Resistant  
Stainless Steel (shown)



Fingerprint Resistant  
Black Stainless Steel



Built-in Look with Counter Depth

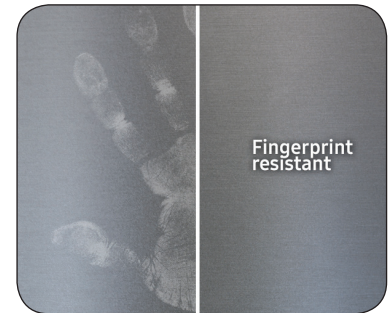

Fingerprint Resistant Finish

### Design

- Built-in Look with Counter Depth
- Fingerprint Resistant Finish
- Minimal Display Dispenser: external filtered water and ice
- LED Lighting
- Four Gallon Door Bins
- Two Clear Drawers

### Convenience

- Wi-Fi and Bixby Enabled
- Adjustable Top Shelf
- Door Alarm
- Water Filter Indicator
- Sabbath Mode

### Performance

- All-Around Cooling
- In-Door Ice Maker - Stores up to 4.4 lbs of ice

### Rating



ENERGY STAR® rated:  
640 kWh/yr



ADA Compliant

# RS22T5201SR

SAMSUNG

## 22 cu. ft. Side-By-Side Counter Depth Refrigerator

### Installation Specifications

1. Measure the height, width and depth of the opening, making sure to include baseboards, molding tile, countertop overhang, etc. Check to be sure there is enough room to open the door (consider walls, islands or other obstacles when measuring).
2. Refer to illustration below to determine dimensions.
3. Allow 2.5" of clearance on hinge side of refrigerator when installing next to a wall where handle may make contact.
4. Allow 1" minimum clearance at rear for proper air circulation and water/electrical connections. Allow a 3/8" minimum clearance at sides and top for ease of installation.
5. Ensure each door and entryway in the home is wide enough for the refrigerator to be moved through easily.

For optimal usage and to be able to open refrigerator doors completely, do not install next to a wall.

Please note: The following dimension and cutout information is for planning purposes only. For complete installation details, consult manual packed with product, or download manual online at [samsung.com](http://samsung.com).



### Dimensions

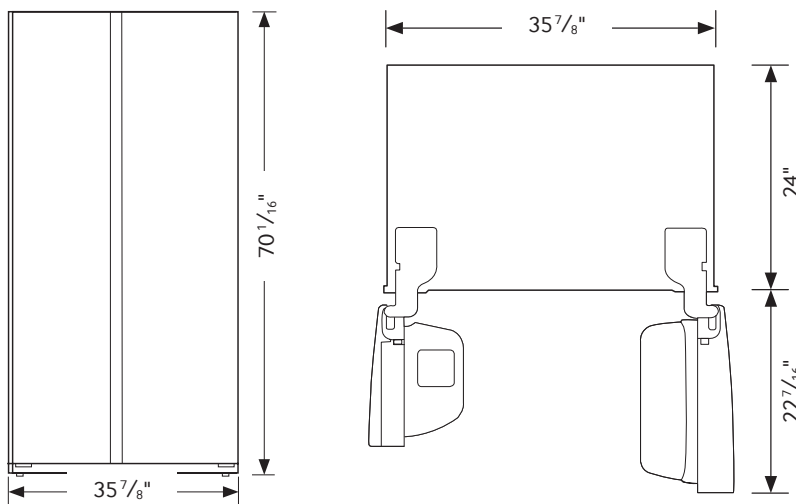

**Total Capacity: 22.0 cu. ft.**

**Refrigerator: 14.6 cu. ft.**

- 4 Tempered Glass Shelves
- 2 Clear Drawers, 1 with Flip Cover
- 5 Door Bins
  - 3 Gallon Bins
  - 2 Door Bins
- LED Lighting

**Freezer: 7.4 cu. ft.**

- External Filtered Water and Ice Dispenser (Crushed or Cubed Ice)
- In-Door Ice Maker
- 5 Tempered Glass Shelves
- 1 Drawer with Flip Cover
- 2 Door Bins
- LED Lighting

### Accessories

Water Filter: HAF-QIN

### Warranty

One (1) Year Parts and Labor on Refrigerator  
Five (5) Years Parts and Labor on Sealed Refrigeration System Only\*  
Ten (10) Years Parts and Five (5) Years Labor on Digital Inverter Compressor

\*Compressor, evaporator, condenser, drier and connecting tubing.

### Product Dimensions & Weight

Dimensions (WxHxD with hinges, handles, doors and dispenser): 35<sup>7</sup>/<sub>8</sub>" x 70<sup>1</sup>/<sub>16</sub>" x 28<sup>5</sup>/<sub>8</sub>"

Dimensions (WxHxD without hinges and door): 35<sup>7</sup>/<sub>8</sub>" x 68<sup>5</sup>/<sub>8</sub>" x 24"

Dimensions (WxHxD with hinge and door, no handle): 35<sup>7</sup>/<sub>8</sub>" x 70<sup>1</sup>/<sub>16</sub>" x 28<sup>5</sup>/<sub>8</sub>"

Weight: 238 lbs

### Shipping Dimensions & Weight (WxHxD)

Dimensions: 37<sup>3</sup>/<sub>4</sub>" x 75<sup>3</sup>/<sub>8</sub>" x 30<sup>1</sup>/<sub>8</sub>"

Weight: 247 lbs

Color	Model #	UPC Code
Fingerprint Resistant Stainless Steel	RS22T5201SR	887276372174
Fingerprint Resistant Black Stainless Steel	RS22T5201SG	887276372167