



# TRENDMAKER HOMES

**Starling** 2,279 Sq. Ft.  
3 Bedrooms | 2 Baths | 2 Car Garage

DS  
DG

DS  
KT

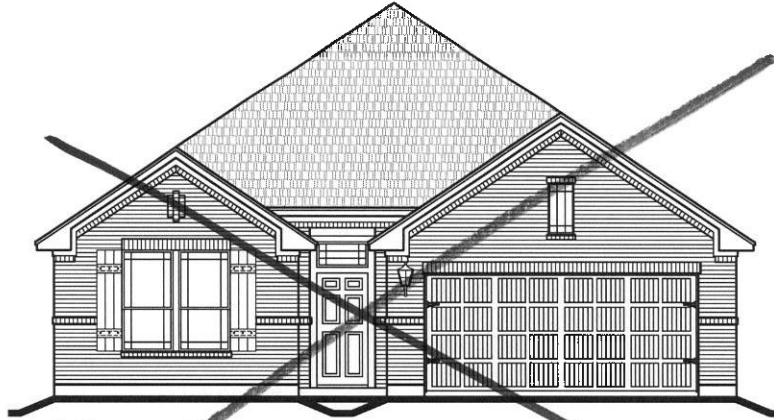

Elevation - A

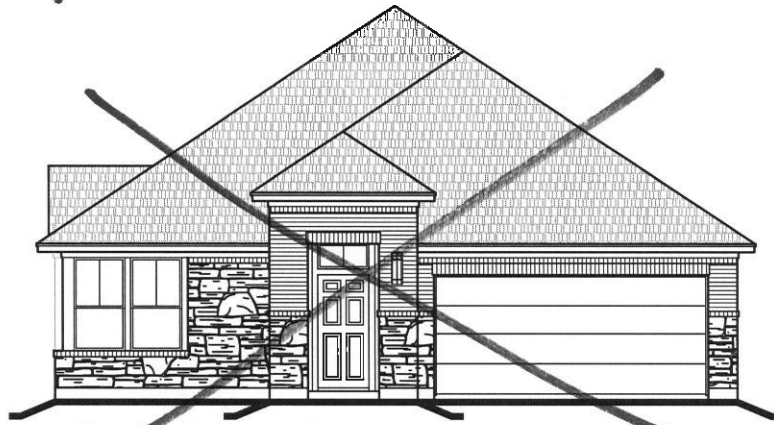

Elevation - B

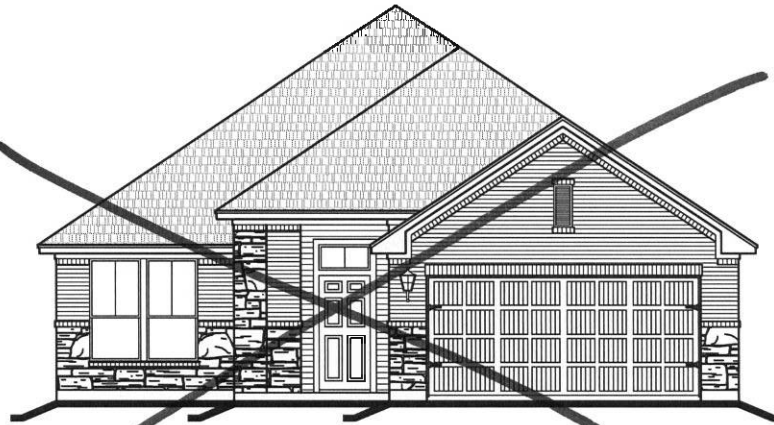

Elevation - C



Elevation - D

Floorplans, square footage, specifications, prices, and available options may vary by elevation and/or community and are subject to change without prior notice. Images are an artist's conception and not a guarantee of final specifications. Please see your Trendmaker New Home Advisor for details and additional information.

TrendmakerHomes.com  
L301

LAST REVISED 02/27/20





# TRENDMAKER HOMES

**Starling** 2,279 Sq. Ft.  
3 Bedrooms | 2 Baths | 2 Car Garage

DS  
DG

DS  
kt

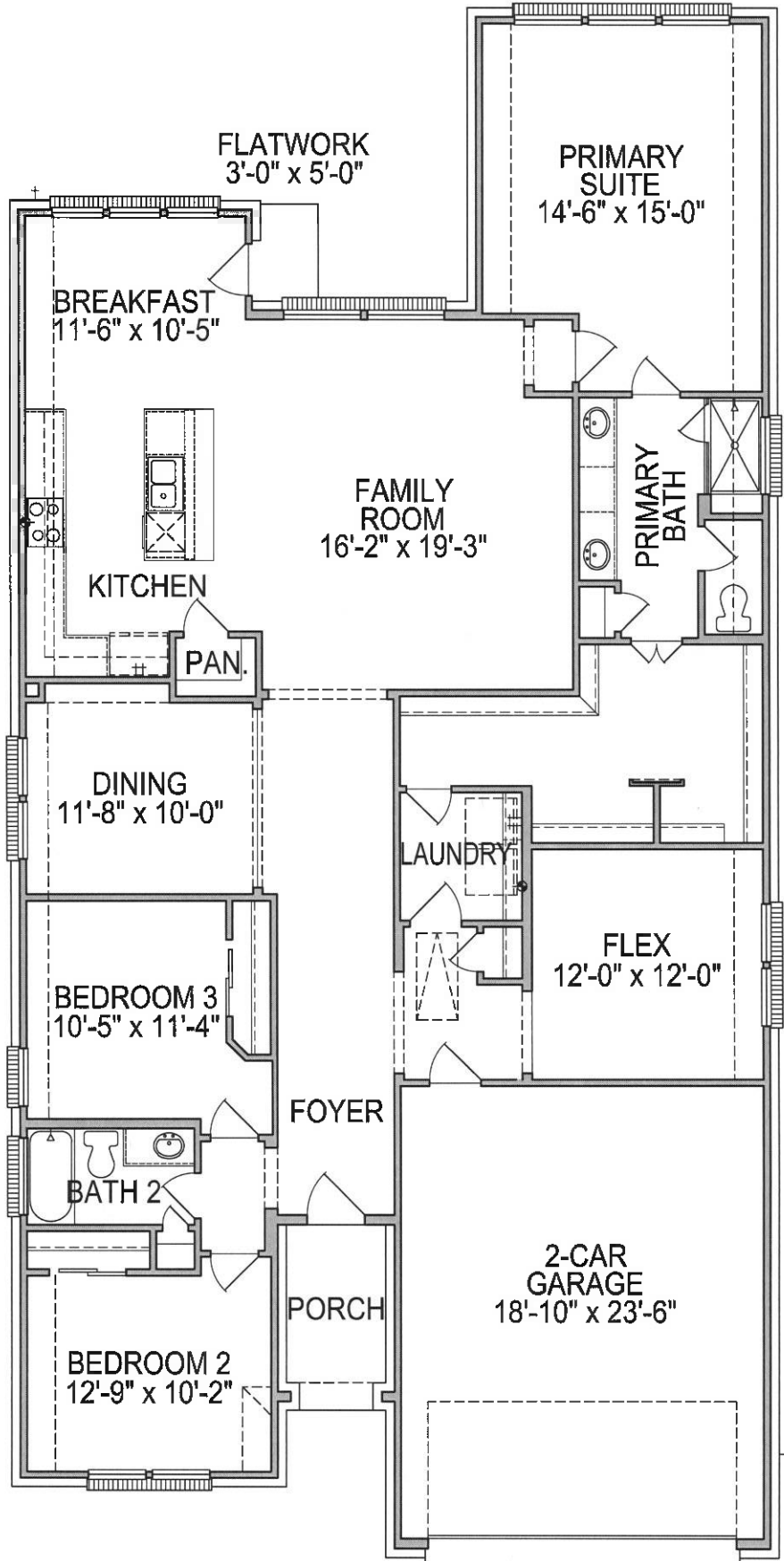

## FIRST FLOOR PLAN

Floorplans, square footage, specifications, prices, and available options may vary by elevation and/or community and are subject to change without prior notice. Images are an artist's conception and not a guarantee of final specifications. Please see your Trendmaker New Home Advisor for details and additional information.

TrendmakerHomes.com  
L301

LAST REVISED 02/27/20





Starling 2,279 Sq. Ft.  
3 Bedrooms | 2 Baths | 2 Car Garage



Plan Options

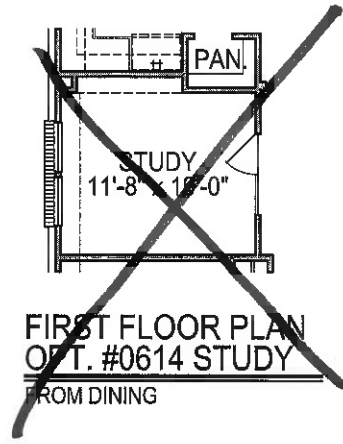
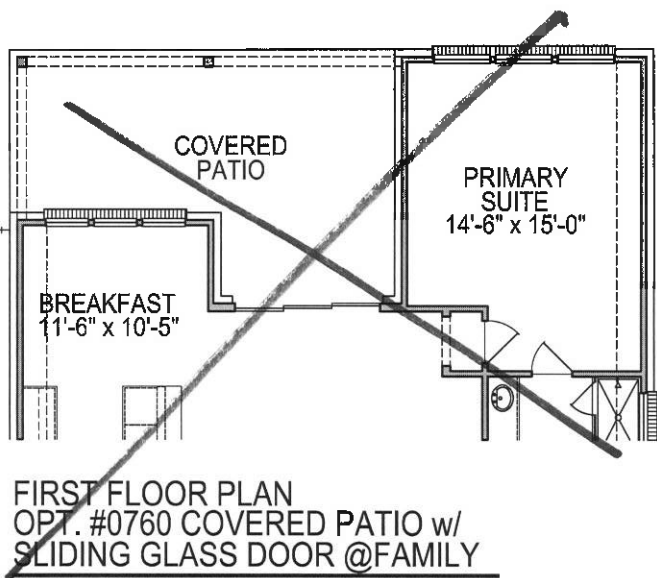
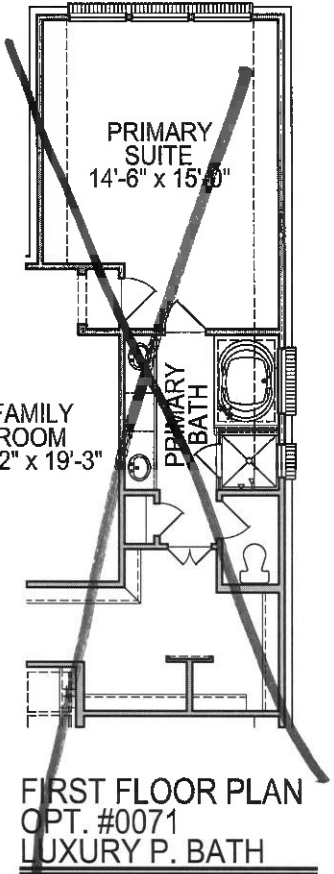
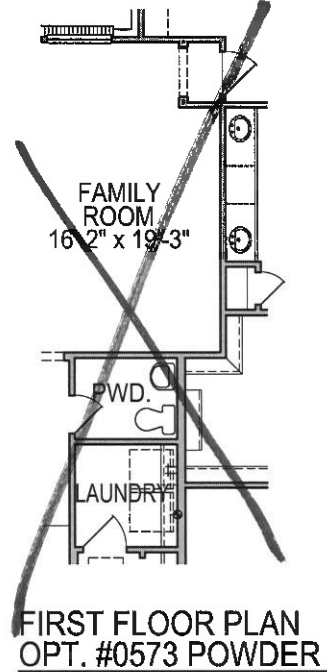
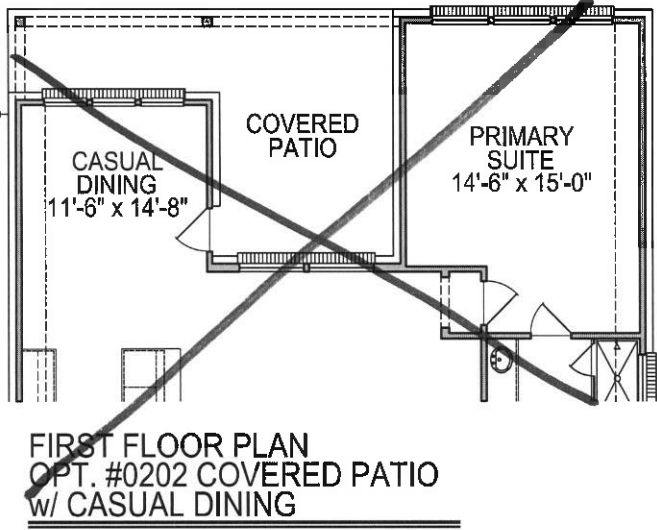
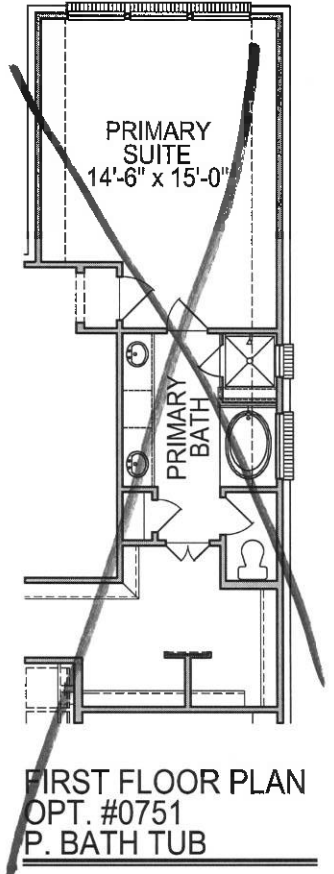
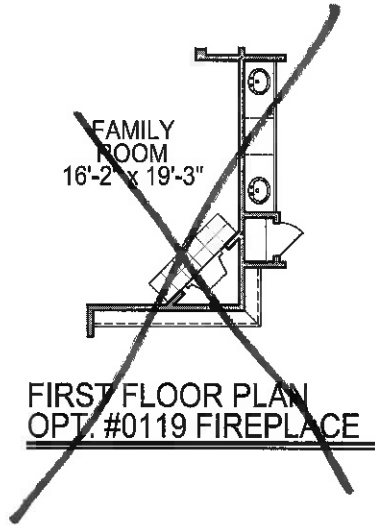
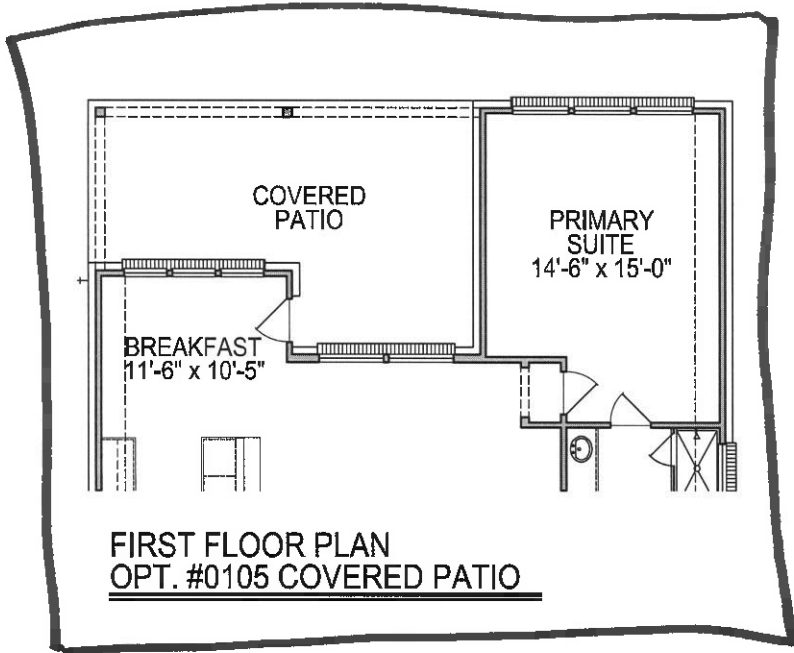

Floorplans, square footage, specifications, prices, and available options may vary by elevation and/or community and are subject to change without prior notice. Images are an artist's conception and not a guarantee of final specifications. Please see your Trendmaker New Home Advisor for details and additional information.





Starling 2,279 Sq. Ft.  
3 Bedrooms | 2 Baths | 2 Car Garage

Plan Options

DS  
DG KT

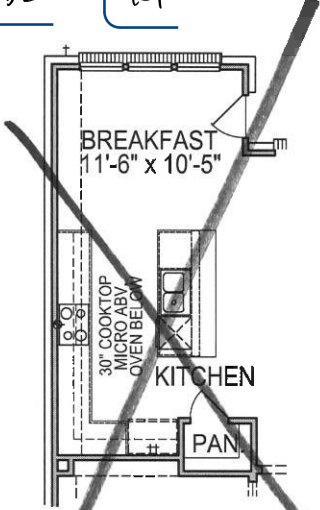

**FIRST FLOOR PLAN  
OPT. #0102 ALT.  
KITCHEN APPLIANCE #1**  
-30" COOKTOP W/ MICRO ABOVE  
-BUILT-IN OVEN BELOW COOKTOP

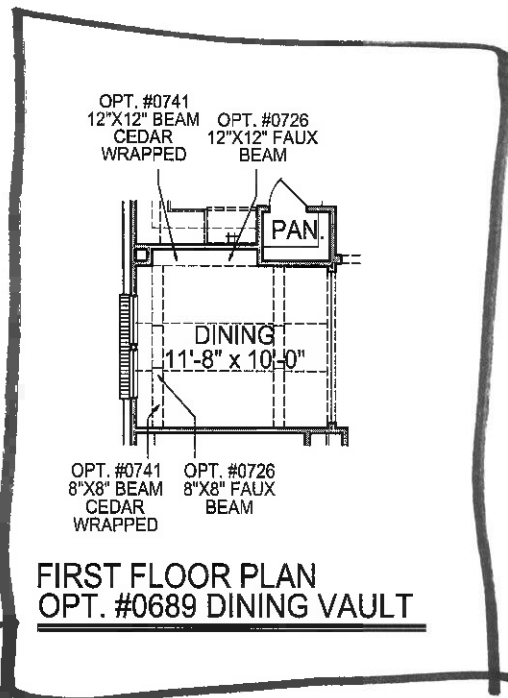

**FIRST FLOOR PLAN  
OPT. #0689 DINING VAULT**

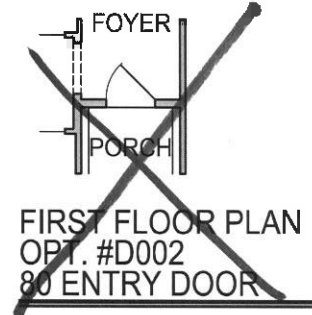

**FIRST FLOOR PLAN  
OPT. #D002  
80" ENTRY DOOR**

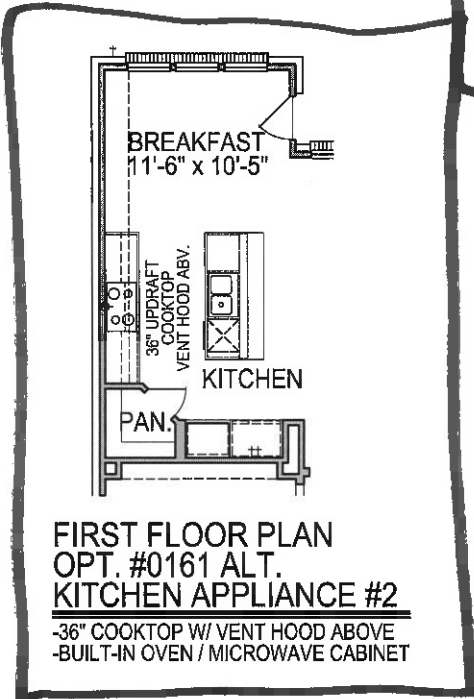

**FIRST FLOOR PLAN  
OPT. #0161 ALT.  
KITCHEN APPLIANCE #2**  
-36" COOKTOP W/ VENT HOOD ABOVE  
-BUILT-IN OVEN / MICROWAVE CABINET

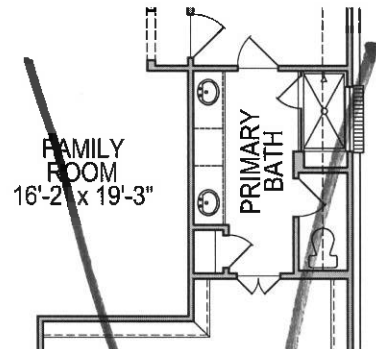

**FAMILY ROOM  
16'-2" x 19'-3"**

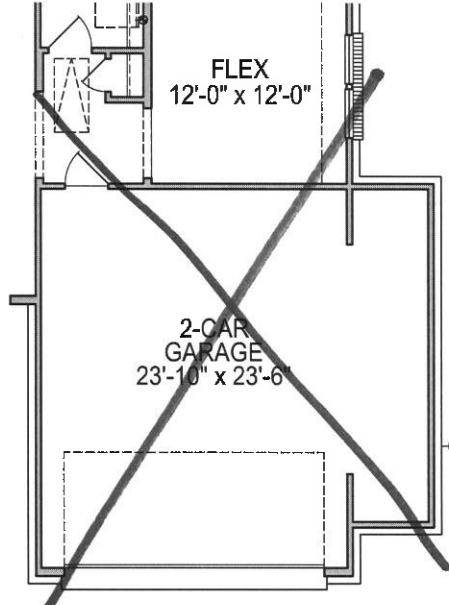

**FIRST FLOOR PLAN  
OPT. #0613 5' GARAGE EXT.**

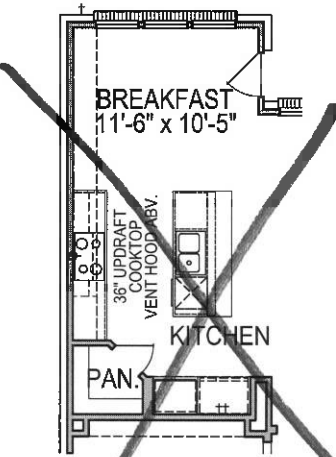

**FIRST FLOOR PLAN  
OPT. #0103 ALT.  
KITCHEN APPLIANCE #3**  
-36" COOKTOP W/ VENT HOOD ABOVE  
-BUILT-IN DOUBLE OVEN CABINET

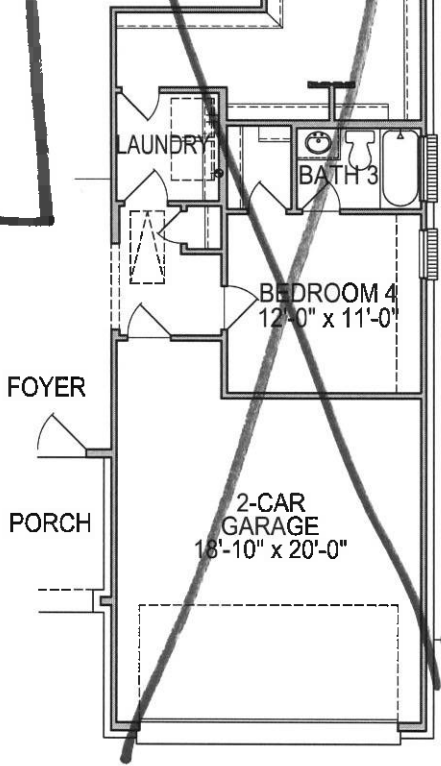

**FIRST FLOOR PLAN  
OPT. #0733 BED 4/BATH 3  
FROM FLEX**

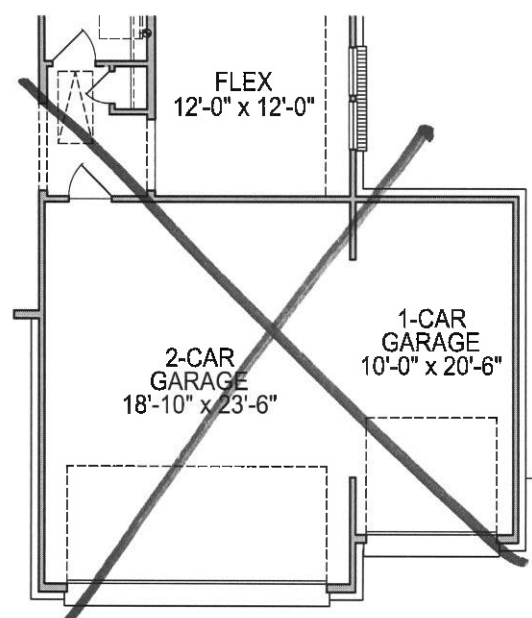

**FIRST FLOOR PLAN  
OPT. #0593 1 CAR GARAGE EXT.**

Floorplans, square footage, specifications, prices, and available options may vary by elevation and/or community and are subject to change without prior notice. Images are an artist's conception and not a guarantee of final specifications. Please see your Trendmaker New Home Advisor for details and additional information.

TrendmakerHomes.com  
L301

LAST REVISED 02/27/20

