

A CUSTOM ADDITION/REMODEL FOR:  
**LDM HOMES, LLC**

4310 APOLLO ST.  
 HOUSTON TX, 77018

SHEET INDEX

ARCHITECTURAL / STRUCTURAL

- P1 ---- SITE PLAN
- P2 ---- CITY OF HOUSTON DETAILS
- P3 ---- CITY OF HOUSTON DETAILS
- D1 ---- DEMOLITION PLAN
- A1 ---- 1ST. FLOOR PLAN
- A2 ---- 1ST. FLOOR PLAN (NO DIMS)
- A3 ---- 2ND. FLOOR PLAN
- A4 ---- 2ND. FLOOR PLAN (NO DIMS)
- A5 ---- FLOOR PLAN NOTES
- A6 ---- 1ST. FLOOR ELECTRICAL PLAN
- A7 ---- 2ND. FLOOR ELECTRICAL PLAN
- A8 ---- EXTERIOR ELEVATIONS (FRONT & RIGHT)
- A9 ---- EXTERIOR ELEVATIONS (REAR & LEFT)
- S1 ---- FOUNDATION PLAN & DETAILS
- S2 ---- 1ST. FLOOR CEILING FRAMING
- S3 ---- 2ND. FLOOR CEILING FRAMING
- S4 ---- ROOF FRAMING PLAN
- S5 ---- NOTES & DETAILS
- S6 ---- NOTES & DETAILS

PROJECT INFORMATION

AREA CALCULATION:		
EXISTING 1ST FLOOR LIVING AREA	1,148	S.F.
PROPOSED 1ST FLOOR LIVING ADDITION	214	S.F.
PROPOSED 2ND FLOOR LIVING AREA	861	S.F.
PROPOSED TOTAL LIVING AREA	1,075	S.F.
TOTAL FLOOR LIVING AREA	2,223	S.F.
EXISTING DETACHED 2-CAR GARAGE	494	S.F.
PROPOSED COV. PORCH	47	S.F.
TOTAL COVERED AREA	2,764	S.F.

VICINITY MAP

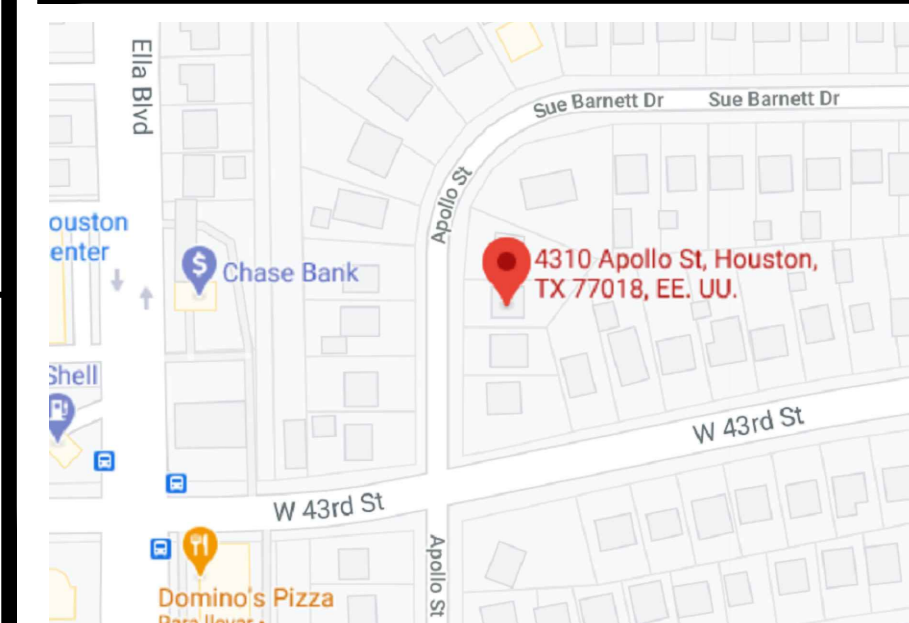

ISSUE DATE: 05-07-21

**DESIGNER**  
 HOUSTON PLANS & PERMITS, LLC  
 1235 N. LOOP WEST, SUITE 1104  
 HOUSTON TX, 77008  
 PLANSANDPERMITS.NET  
 (281) 372-1555

BY	REV.	DESCRIPTION	DATE
DRAWN BY: BH			DATE DRAWN: 10-14-20
CHECKED BY:			

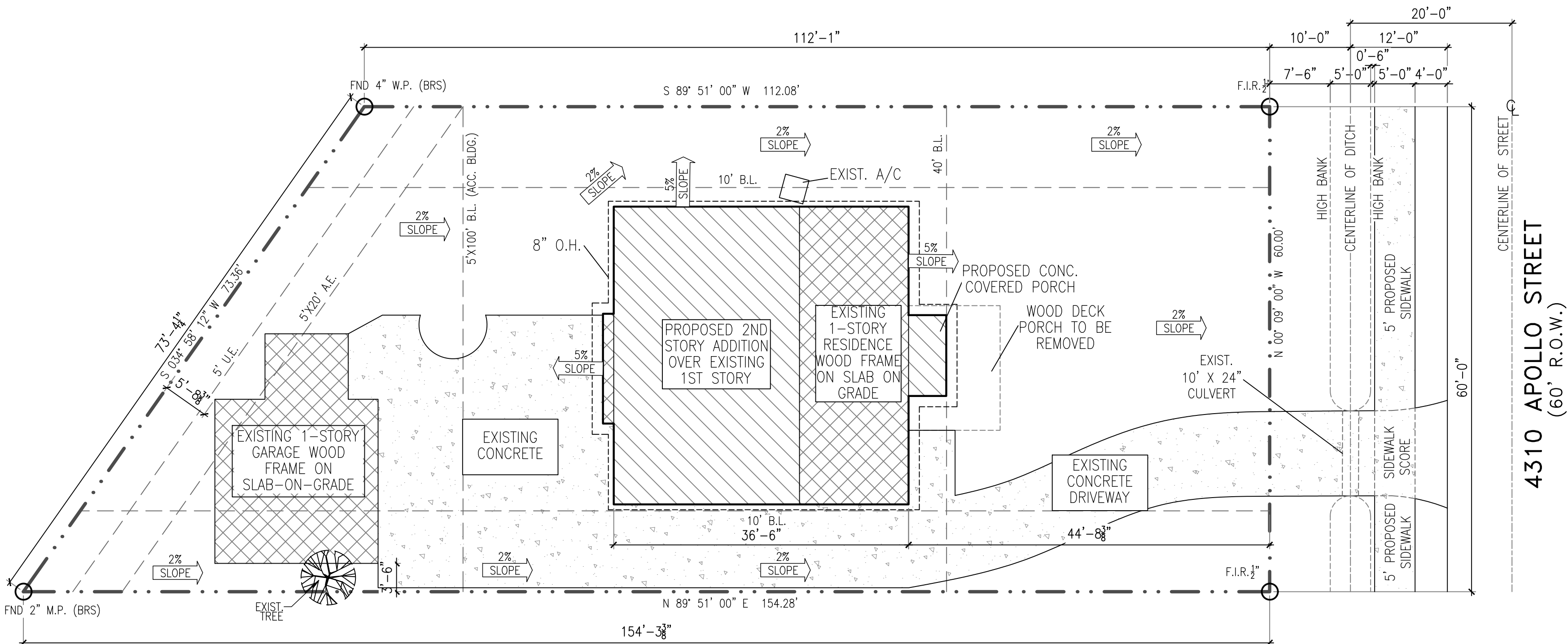

4310 APOLLO STREET  
 (60' R.O.W.)

**GENERAL NOTES**

- Type M copper tubing and pipe shall not be used
- Water riser must be metal above ground schedule 40 PVC may only be used on the exterior of the building below grade
- Entire project shall be constructed in accordance with 2012 I.R.C. and the 2012 NEC
- Refer to structural for compliance with wind load design criteria
- Aluminum wiring shall not be used and copper 12/2 with ground is the smallest conductor size allowed
- All drainage and runoff shall be collected on-site or directed on surface to street. Drainage and runoff is not allowed to be directed on to adjacent properties.
- All mechanical equipment exhaust must terminate on the exterior of the structure
- Fences require a separate permit
- General contractor Must verify all dimensions for set backs, utility easements, and bldg lines.

**IMPERVIOUS AREA PERCENTAGE CALCULATION**

	ADDITION SQ. FT.	FINAL SQ. FT.
1. BUILDINGS	1,903 SF	1,903 SF
2. PAVING	1,856 SF	1,856 SF
<b>TOTALS</b>	<b>3,759 SF</b>	<b>3,759 SF</b>

**TOTAL AREA OF LOT: 7,990 SF**  
 ( 3,759 SF / 7,990 SF ) X 100= 47.04%

**NOTE:**  
 F.F. ELEV. NOT LESS THAN 12" ABOVE NEAREST SANITARY SEWER MANHOLE RIM, OR 4" ABOVE THE CROWN OF STREET, EXCEPT ON FLOOD ZONE TO BE VERIFIED WITH APPLICABLE CODE REQUIREMENTS FOR FINISH FLOOR ELEVATION.

**CONTRACTOR TO VERIFY WITH APPLICABLE CODE REQUIREMENTS FOR FIN. FLOOR ELEVATION**

**DRAINAGE NOTES**

DRAINAGE (LOTS) R401.3 2012 IRC (EFFECTIVE JUNE 6, 2012) LOTS SHALL BE GRADED TO PROVIDE A POSITIVE DRAINAGE PATH AWAY FROM THE FOUNDATION. THE FALL SHALL BE A MINIMUM OF 8 INCHES IN THE FIRST 10 FEET (5% SLOPES). THE SITE PLAN SHALL DEPICT THE SLOPES.

DRAINAGE (LOTS) R401.3 EXCEPTION 2012 IRC AMENDMENTS (EFFECTIVE JUNE 6, 2012) IF A SWALE OR DRAIN IS USED DUE TO A PHYSICAL BARRIER OR LOT LINE THE PLANS MUST INDICATE THE POSITIVE DRAINAGE DETAILS. IMPERVIOUS SURFACES WITHIN 10 FEET OF THE BUILDING FOUNDATION SHALL BE SLOPE A MINIMUM OF 2% AWAY FROM THE BUILDING.

**NOTE:**  
 ALL EXISTING TREES ON THE LOT WILL REMAIN UNLESS OTHERWISE NOTED.

**NOTE:**  
 EXISTING DRIVEWAY/CULVERT, TO BE REMAIN AS IS.

**LOT 25, BLK 55  
 GARDEN OAKS SEC 5**

**SITE PLAN**

SCALE: 3/32"=1'-0"

**PROJECT: LDM HOMES, LLC**

**ADDRESS: 4310 APOLLO ST.**

**HOUSTON, TX 77018**  
**DESIGNER ADDRESS:**  
 1235 North Loop West Suite #1104 Houston TX, 77008  
 information@plansandpermits.net  
 P: 281.372.1555



**SHEET NO.**

**P1**









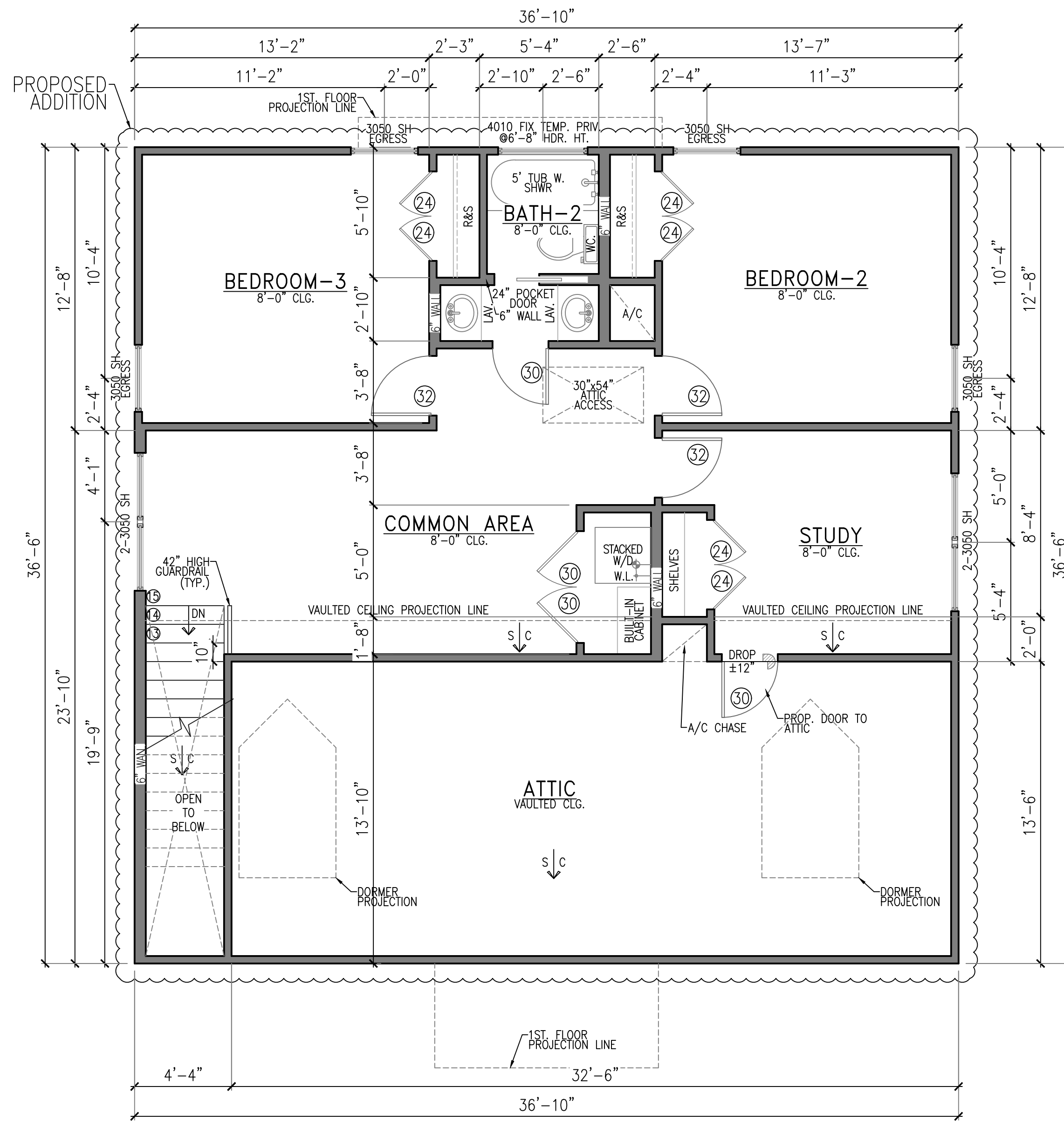

AREA CALCULATION:	
EXISTING 1ST FLOOR LIVING AREA	1,148 S.F.
PROPOSED 1ST FLOOR LIVING ADDITION	214 S.F.
PROPOSED 2ND FLOOR LIVING AREA	861 S.F.
PROPOSED TOTAL LIVING AREA	1,075 S.F.
TOTAL FLOOR LIVING AREA	2,223 S.F.
EXISTING DETACHED 2-CAR GARAGE	494 S.F.
PROPOSED COV. PORCH	47 S.F.
TOTAL COVERED AREA	2,764 S.F.

FLOOR PLAN NOTES
SEE NOTES ON SHEET "A5"

TO THE BEST OF MY KNOWLEDGE, THESE PLANS ARE DRAWN TO COMPLY WITH OWNERS'S SPECIFICATIONS. CONTRACTOR AND/OR OWNER SHALL VERIFY ALL DIMENSIONS, DETAILS, AND SPECIFICATIONS BEFORE CONSTRUCTION. DESIGNER WILL NOT BE LIABLE FOR HUMAN ERROR AFTER CONSTRUCTION IS STARTED. THE INFORMATION, SPECIFICATIONS, AND DESIGNS APPEARING IN THIS SHEET ARE PROPERTY OF HOUSTON PLANS AND PERMITS, LLC. ANY UNAUTHORIZED USE OR DUPLICATION IN WHOLE OR IN PART IS STRICTLY PROHIBITED.

\*\*NOTE: CLIENT TO VERIFY SIZE OF WINDOWS DUE TO CHANGE IN CEILING HEIGHT

FLOOR PLAN  
 2ND FLOOR

SCALE: 1/4"=1'-0"

BY	REV.	DESCRIPTION	DATE

DATE DRAWN: 10-14-20  
 DRAWN BY: BH  
 CHECKED BY:

PROJECT: **LDM HOMES, LLC**  
 ADDRESS: 4310 APOLLO ST.  
 HOUSTON, TX 77018  
 DESIGNER ADDRESS:  
 1235 North Loop West Suite #1104 Houston TX, 77008  
 information@plansandpermits.net  
 P: 281.372.1555

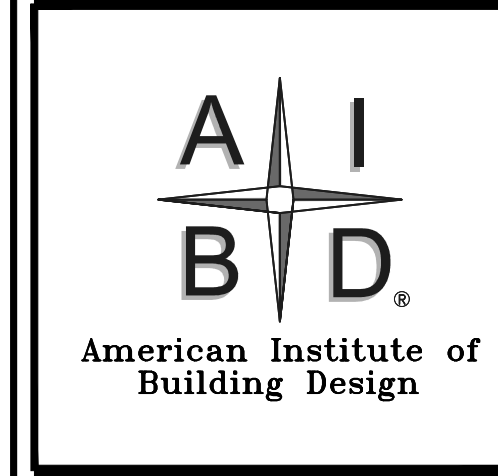

SHEET NO.  
**A3**







AREA TO BE REMODELED

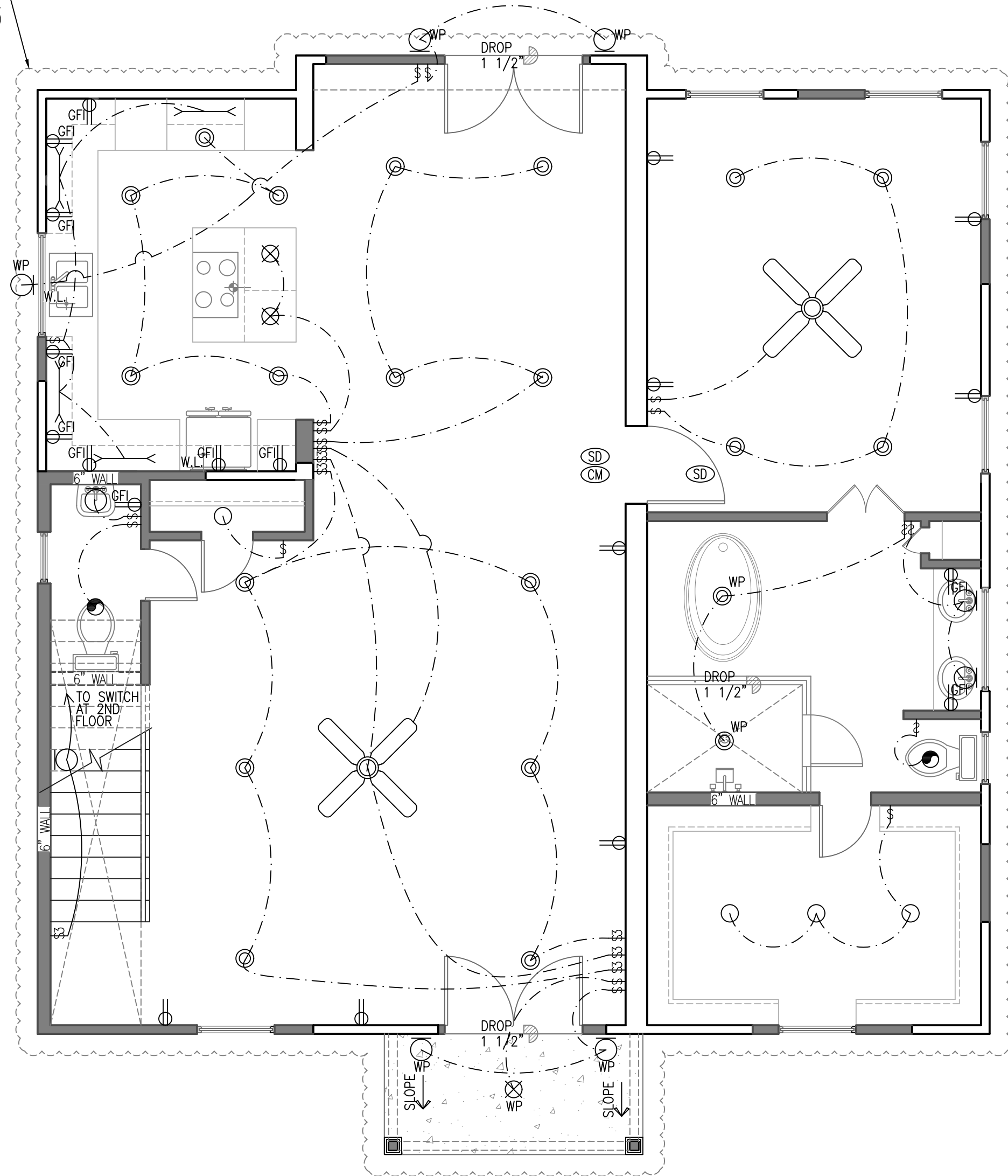

ELECTRICAL PLAN NOTES
SEE NOTES ON SHEET "A5"

TO THE BEST OF MY KNOWLEDGE, THESE PLANS ARE DRAWN TO COMPLY WITH OWNERS'S SPECIFICATIONS. CONTRACTOR AND/OR OWNER SHALL VERIFY ALL DIMENSIONS, DETAILS, AND SPECIFICATIONS BEFORE CONSTRUCTION. DESIGNER WILL NOT BE LIABLE FOR HUMAN ERROR AFTER CONSTRUCTION IS STARTED. THE INFORMATION, SPECIFICATIONS, AND DESIGNS APPEARING IN THIS SHEET ARE PROPERTY OF HOUSTON PLANS AND PERMITS, LLC. ANY UNAUTHORIZED USE OR DUPLICATION IN WHOLE OR IN PART IS STRICTLY PROHIBITED.

**ELECTRICAL PLAN**  
1ST FLOOR

SCALE: 1/4"=1'-0"

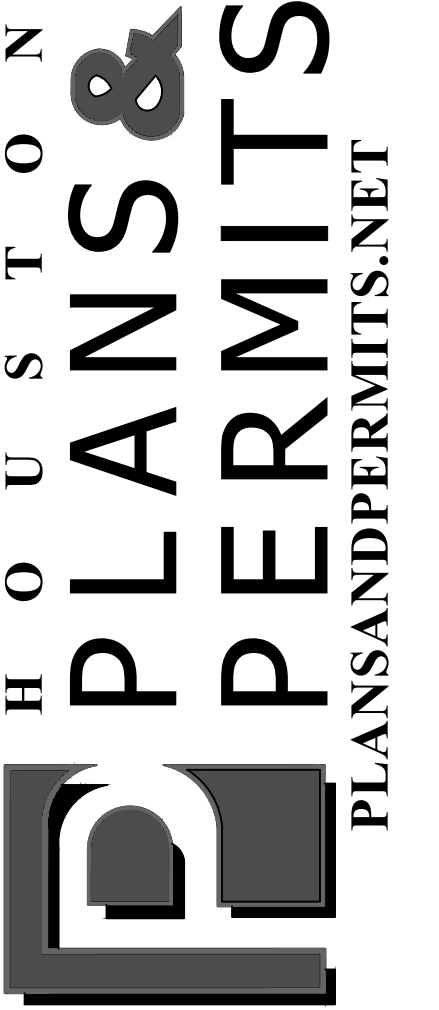

BY	REV.	DESCRIPTION	DATE

DRAWN BY: BH  
CHECKED BY:   
DATE DRAWN: 10-14-20

PROJECT: **LDM HOMES, LLC**

ADDRESS: **4310 APOLLO ST.**

DESIGNER ADDRESS: **HOUSTON, TX 77018**  
1235 North Loop West Suite #1104 Houston TX, 77008  
information@plansandpermits.net  
P: 281.372.1555



**SHEET NO.**

**A6**



TO THE BEST OF MY KNOWLEDGE, THESE PLANS ARE DRAWN TO COMPLY WITH OWNERS'S SPECIFICATIONS. CONTRACTOR AND/OR OWNER SHALL VERIFY ALL DIMENSIONS, DETAILS, AND SPECIFICATIONS BEFORE CONSTRUCTION. DESIGNER WILL NOT BE LIABLE FOR HUMAN ERROR AFTER CONSTRUCTION IS STARTED. THE INFORMATION, SPECIFICATIONS, AND DESIGNS APPEARING IN THIS SHEET ARE PROPERTY OF HOUSTON PLANS AND PERMITS, LLC. ANY UNAUTHORIZED USE OR DUPLICATION IN WHOLE OR IN PART IS STRICTLY PROHIBITED.

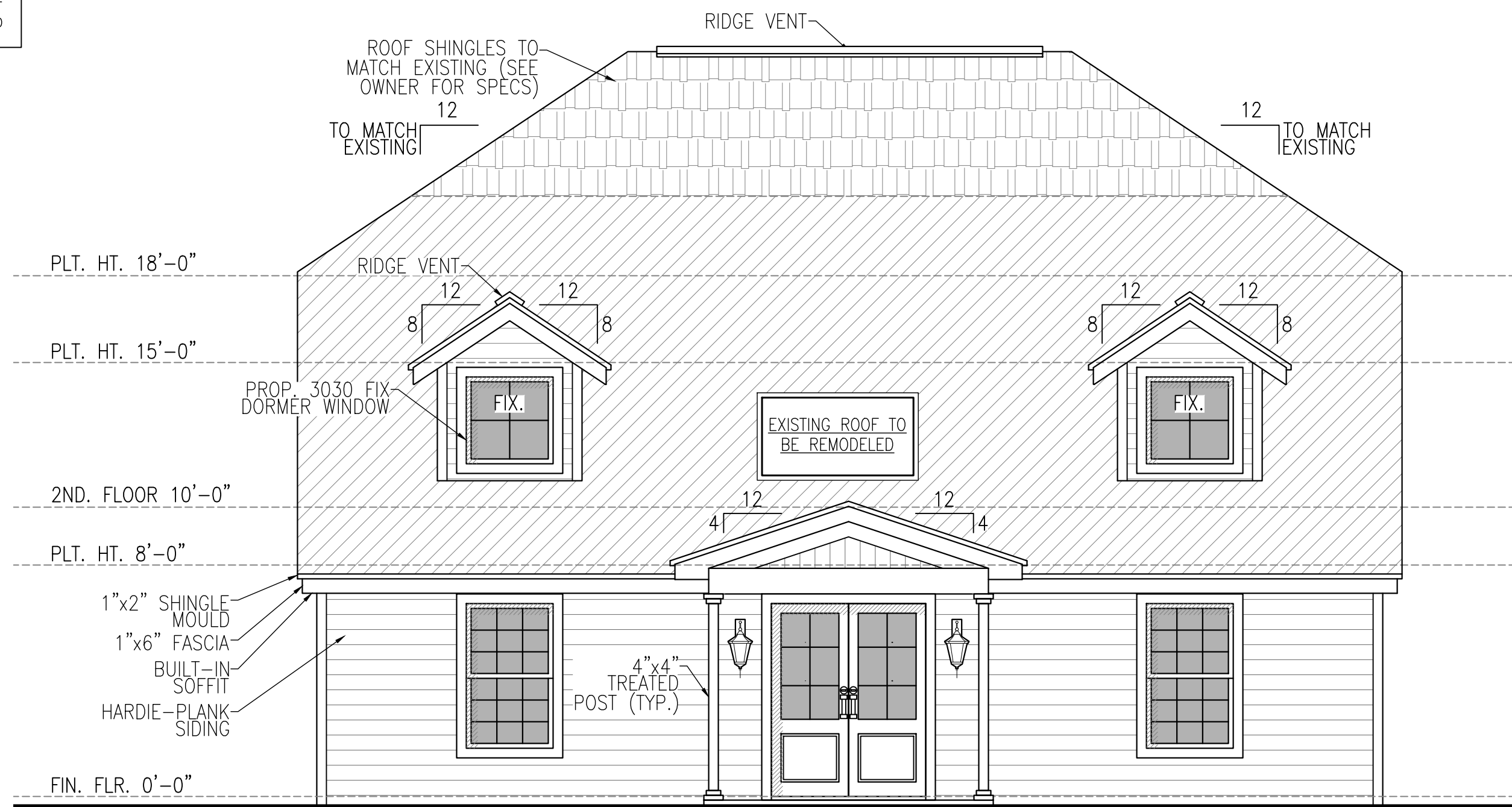

**EXTERIOR ELEVATION**

FRONT

SCALE: 1/4"=1'-0"

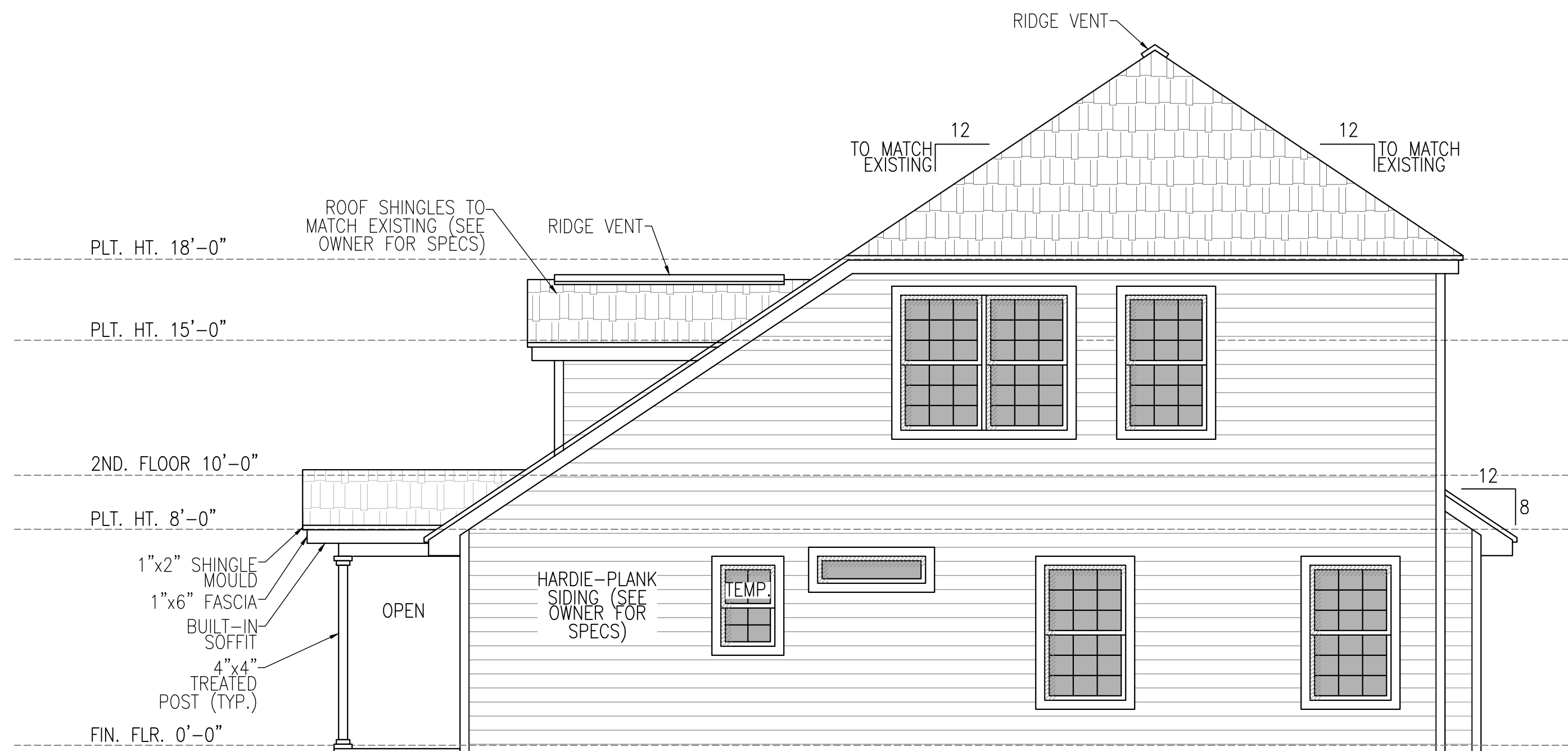

**EXTERIOR ELEVATION**

RIGHT

SCALE: 1/4"=1'-0"

BY	REV.	DESCRIPTION	DATE

DRAWN BY: BH  
 CHECKED BY:  
 DATE DRAWN: 10-14-20

**PROJECT: LDM HOMES, LLC**

**ADDRESS: 4310 APOLLO ST.**

**HOUSTON, TX 77018**

**DESIGNER ADDRESS:**  
 1235 North Loop West Suite #1104 Houston TX, 77008  
 information@plansandpermits.net  
 P: 281.372.1555



**American Institute of Building Design**

**SHEET NO.**

**A8**





**GENERAL FOUNDATION NOTES**

- GENERAL NOTES:
  - THESE GENERAL NOTES SHALL APPLY TO THE STRUCTURAL DRAWINGS, UNLESS OTHERWISE NOTED.
  - UNLESS OTHERWISE INDICATED, ALL DETAILS OF DESIGN, WORKMANSHIP AND MATERIALS SHALL CONFORM TO THE LATEST EDITION OF THE INTERNATIONAL RESIDENTIAL CODE (IRC - 2012), WITH CITY OF HOUSTON AMENDMENTS, SOUTHERN BUILDING CODE, TEXAS WIND STORM BUILDING STORM CODE, TEXAS WIND STORM CONSTRUCTION GUIDELINES AND LOCAL BUILDING CODES.
- FOUNDATION NOTES:
  - SEE FOUNDATION PLAN FOR LOCATIONS OF BEAMS, BELLBOTTOMS, DROPS, ETC. THE CONTRACTOR SHALL VERIFY OVERALL DIMENSIONS AND PLUMBING LOCATION PRIOR TO POURING CONCRETE.
  - ALL FOUNDATION EXCAVATION TO BE CARRIED TO UNDISTURBED MATERIAL OR PLACED IN APPROVED ENGINEERED FILL. EXCAVATIONS SHALL BE FREE OF LOOSE MATERIAL AND WATER.
  - OVER EXCAVATION OF MATERIALS SHALL BE BACKFILLED WITH CONCRETE.
  - ALL BACKFILL AROUND FOOTINGS, BEHIND WALLS AND UNDER SLABS SHALL BE COMPACTED. SEE SOIL REPORT FOR SITE PREPARATION SPECIFICATIONS, IF AVAILABLE.
  - BACKFILLS AGAINST FOUNDATION WALLS WILL NOT BE PERMITTED UNTIL THE WALL HAS REACHED 28 DAY STRENGTH AND ALL SUPPORTING STRUCTURE IS IN PLACE.
  - STEP FOOTING AT A RATIO OF ONE VERTICAL TO TWO HORIZONTAL, WITH A MAXIMUM VERTICAL STEP OF 2'-0" UNLESS NOTED OTHERWISE.
  - WATERPROOFING OF FOUNDATIONS AND RETAINING WALLS SHALL BE THE RESPONSIBILITY OF THE OWNER OR CONTRACTOR AND IS NOT THE RESPONSIBILITY OF THE ENGINEER.
  - ANY UNUSAL SITE CONDITIONS (e.g. LOOSE FILL, SUBSURFACE WATER, ETC.) SHALL BE REPORTED TO THE ENGINEER.
  - CONCRETE AND REINFORCING FOR DRILLED FOOTINGS SHALL BE PLACED IMMEDIATELY AFTER EXCAVATION.
  - ALL PIPES THROUGH EXTERIOR GRADE BEAMS SHALL BE SLEEVED. ALL PIPES SHALL BE LOCATED AT MID-DEPTH OF GRADE BEAMS. SIZE OF SLEEVES SHALL NOT EXCEED 1/3 OVERALL DEPTH OF GRADE BEAM. SPACING OF SLEEVES SHALL NOT BE CLOSER THAN 5 DIAMETERS ON THE CENTER.
- REINFORCING CONCRETE:
  - REINFORCING CONCRETE SHALL CONFORM TO APPLICABLE REQUIREMENTS OF THE IRC-2012 AND A.C.I. STANDARD 318.
  - ALL CONCRETE USED IN FOUNDATIONS AND SLABS ON GRADE SHALL HAVE A 28 DAY COMPRESSIVE STRENGTH OF NOT LESS THAN 3000 psi.
  - THE MAXIMUM SLUMP SHALL NOT EXCEED 5 INCHES.
  - PROVIDE # 3's @ 15" ON CENTER EACH WAY IN ALL SLABS ON GRADE, PLACED 1 1/2" DOWN FROM TOP OF SLAB, UNLESS OTHERWISE NOTED.
  - PROVIDE WELDED WIRE FABRIC IN FLAT SHEETS, NOT IN ROLLS.
  - PROVIDE CONTROL JOINTS IN ALL EXPOSED SLABS ON GRADE. THE MAXIMUM SPACING OF CONTROL JOINTS SHALL BE 20'-0" O.C., UNLESS OTHERWISE NOTED.
  - POUR SLAB IN STRIP POURS, NOT IN CHECKERBOARD PATTERN.
  - PROVIDE VERTICAL CONTROL JOINTS IN ALL CONCRETE WALLS. THE MAXIMUM SPACING OF CONTROL JOINTS SHALL BE 20'-0", UNLESS OTHERWISE NOTED. CUT ALTERNATE HORIZONTAL REINFORCING BARS, EACH FACE.
  - ADDITIVES CONTAINING CALCIUM CHLORIDE SHALL NOT BE USED.
- REINFORCING STEEL:
  - ALL REINFORCING STEEL SHALL CONFORM TO ASTM A615 GRADE 60 UNLESS OTHERWISE INDICATED, EXCEPT #3 OR SMALLER MAY BE ASTM A615 GRADE 40.
  - WELDED WIRE FABRIC SHALL CONFORM TO ASTM A185.
  - ALL REINFORCING STEEL SHALL BE ACCURATELY LOCATED AND ADEQUATELY SECURED IN POSITION BEFORE AND DURING PLACEMENT OF CONCRETE.
  - ALL DETAILS OF FABRICATION AND INSTALLATION OF REINFORCING STEEL SHALL BE IN ACCORDANCE WITH THE ACI MANUAL OF STANDARD PRACTICE.
  - LAP REINFORCING BAR SPLICES 40 BAR DIAMETERS, UNLESS OTHERWISE NOTED. (SPLICE REINFORCING STEEL 36" WHEN ALL BARS ARE SPLICED AT ANY ONE POINT).
  - BEND ALL HORIZONTAL BEAM AND WALL BARS 40 BAR DIAMETERS AROUND ALL CORNERS, OR 40 BAR DIAMETERS, SPLICE CORNER BARS, UNLESS OTHERWISE NOTED.
  - PROVIDE VERTICAL AND HORIZONTAL REINFORCING BARS IN CONCRETE AND MASONRY WALLS TO CONFORM TO THE MINIMUM PROVISIONS OF ACI 318, SECTION 14.3, UNLESS OTHERWISE NOTED.
  - PROVIDE THE FOLLOWING MINIMUM CONCRETE COVER OVER REINFORCING STEEL:  
CONCRETE CAST AGAINST AND PERMANENTLY EXPOSED TO EARTH . . . 3"  
CONCRETE EXPOSED TO EARTH OR WEATHER . . . 1 1/2"  
CONCRETE NOT EXPOSED TO WEATHER OR IN CONTACT WITH EARTH . . . 3/4"

**NOTE:**

F.F. ELEV. NOT LESS THAN 12" ABOVE NEAREST SANITARY SEWER MANHOLE RIM, OR 4" ABOVE THE CROWN OF STREET, EXCEPT ON FLOOD ZONE TO BE VERIFIED WITH APPLICABLE CODE REQUIREMENTS FOR FINISH FLOOR ELEVATION.

**NOTES:**

- SEE ARCHITECTURAL DWGS. FOR PLUMBING, EMBEDDED ITEMS, RECESSES UTILITIES ETC.
- COORDINATE ALL DIMENSIONS ( IF REQUIRED ) WITH ARCHITECTURAL DRAWINGS.
- CONTRACTOR PLEASE VERIFY ALL WALK DOOR AND O.H. DOOR LOCATIONS.
- SEE STRUCTURAL DWGS FOR ANCHORS, ETC.
- VERIFY FOUNDATION SLOPES WHERE REQUIRED

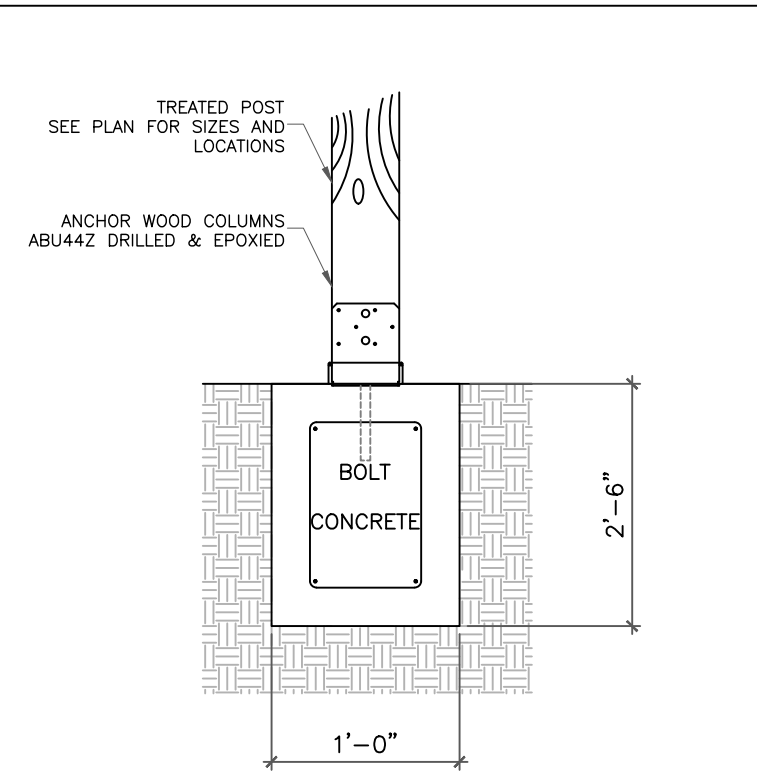

1 FOUNDATION DETAIL  
NOT TO SCALE

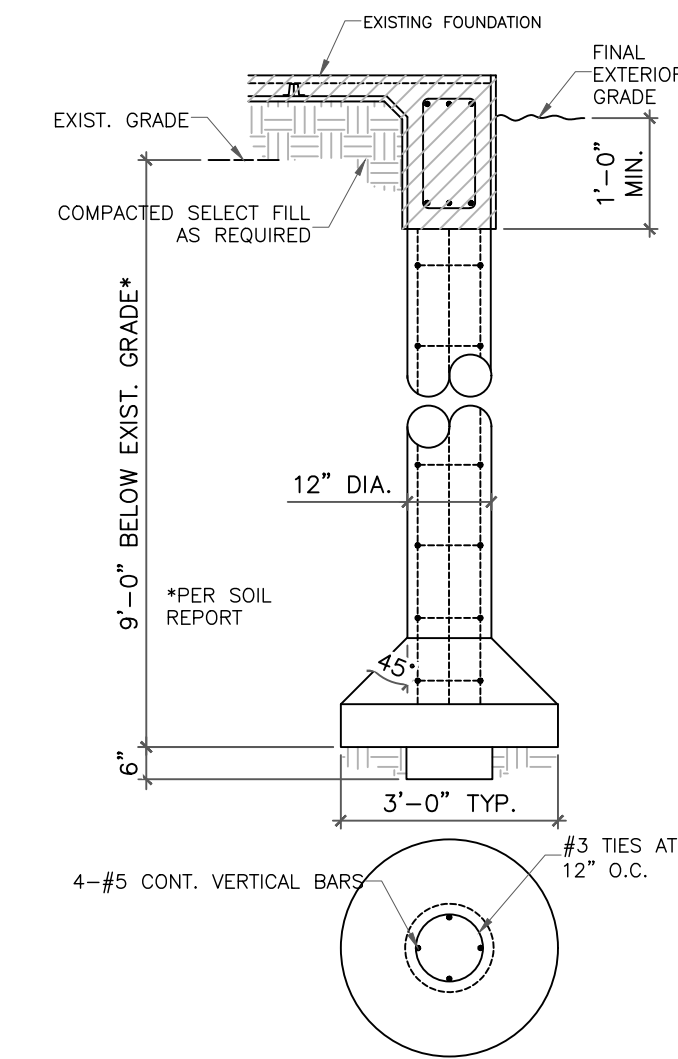

2 FOUNDATION DETAIL  
NOT TO SCALE

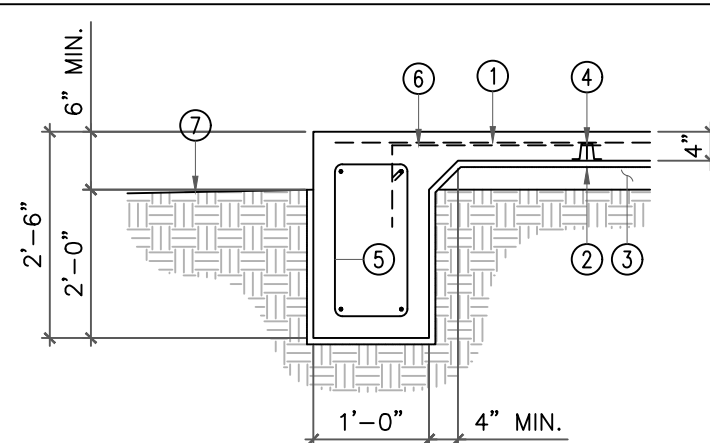

4 FOUNDATION DETAIL  
NOT TO SCALE

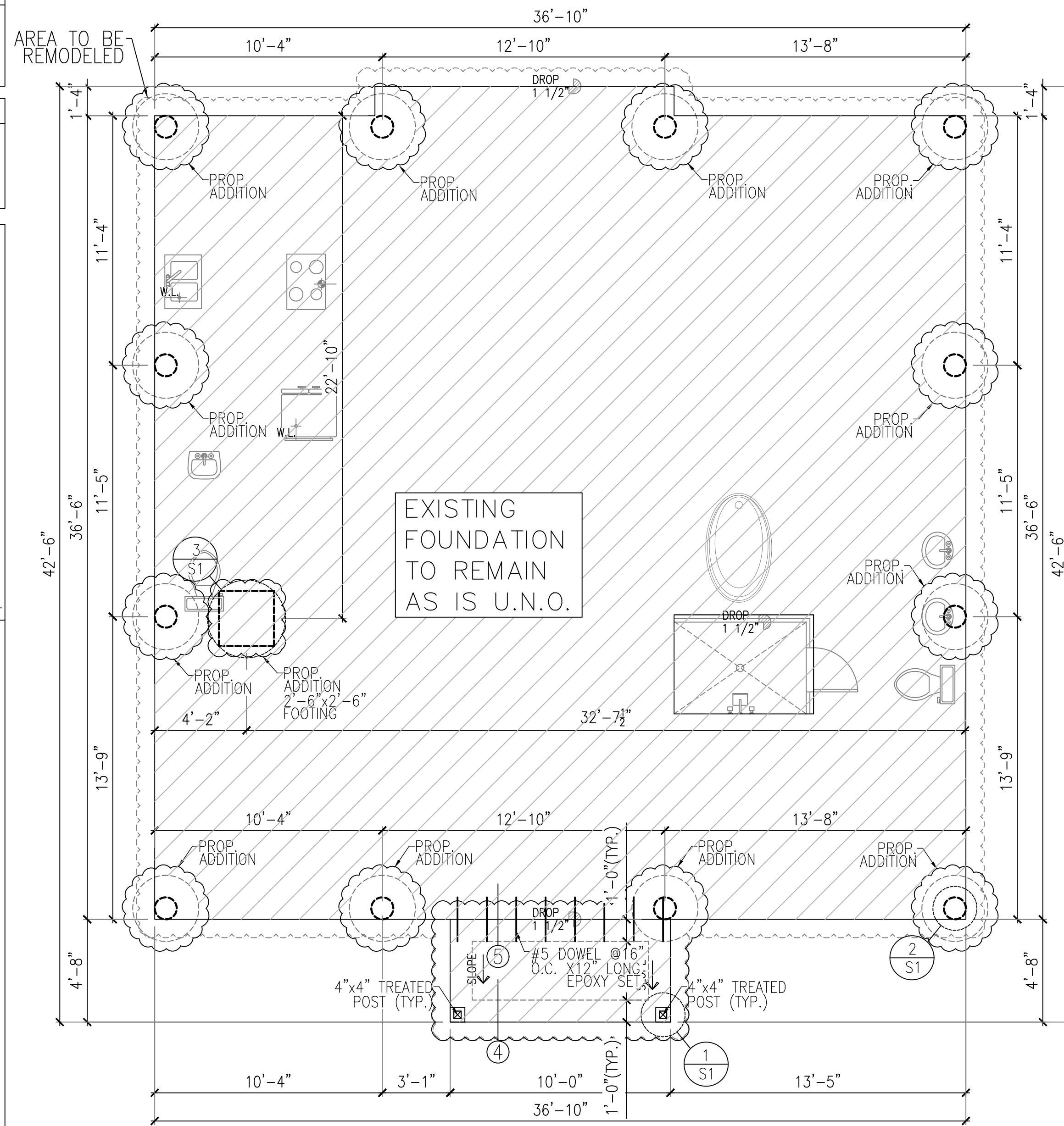

**NOTE:**

ALL SITE WORK PREPARATIONS SHALL BE PER GEOTECHNICAL REPORT  
REFERENCE: GEOTECHNICAL INVESTIGATION PROPOSED HOUSE BUILDING AT 1443 BLAIR STREET HOUSTON, TEXAS 77008 PROJECT No. G2020-164 AUGUST 05,2020  
BY: ASSOCIATED TESTING LABORATORIES 3143 YELLOWSTONE BLVD., HOUSTON, TEXAS 77054 TEL: 713-748-3717 FAX: 713-748-3748

**NOTE:**

SITE PREPARATION SHALL BE AS PER SOIL REPORT

**FOUNDATION PLAN**

SCALE: 1/4"=1'-0"

**NOTE:**

CONTRACTOR TO VERIFY FOUNDATION FOOTPRINT WITH ARCHITECTURAL PLAN PRIOR TO CONSTRUCTION

**NOTE:**

STRUCTURAL PLANS TO BE DESIGNED & REVIEWED BY A TEXAS STRUCTURAL LICENSED ENGINEER

**NOTE:**

TO THE BEST OF MY KNOWLEDGE, THE SOIL IS ADEQUATE FOR THE SIZE AND LOADS OF THE PROPOSED HOUSE. THE FOUNDATION IF CONSTRUCTED AS SHOWN IN THE PERMIT DRAWING WOULD BE IN CONFORMANCE WITH THE SPECIFICATIONS AND THE APPLICABLE WORKMANSHIP PROVISION OF THE IRC-2012 BUILDING CODE.

FOR S1: 1 POUND PER SQUARE FOOT = 0.0479 KPA.  
a. WHEN SOIL TESTS ARE REQUIRED BY SECTION R401.4, THE ALLOWABLE BEARING CAPACITIES OF THE SOIL SHALL BE PART OF THE RECOMMENDATIONS.  
b. WHERE THE BUILDING OFFICIAL DETERMINES THAT IN-PLACE SOILS WITH AN ALLOWABLE BEARING CAPACITY OF LESS THAN 1,500 PSF ARE LIKELY TO BE PRESENT AT THE SITE, THE ALLOWABLE BEARING CAPACITY SHALL BE DETERMINED BY A SOILS INVESTIGATION.

3 FOUNDATION DETAIL  
NOT TO SCALE

5 FOUNDATION DETAIL  
NOT TO SCALE

**LDM HOMES, LLC**

4310 APOLLO ST.

HOUSTON, TX 77018

PROJECT:

ADDRESS:

**SHEET NO.**

**S1**



USE	LIVE LOAD
ATTICS W/ LIMITED STORAGE	20
ATTIC W/O STORAGE	10
DECKS	40
EXTERIOR BALCONIES	60
FIRE ESCAPES	40
GUARDRAILS AND HANDRAILS	200i
GUARDRAILS IN-FILL COMPONENTS	50i
PASSENGER VEHICLE GARAGES	50a
ROOMS OTHER THAN SLEEPING ROOMS	40
SLEEPING ROOMS	30
STAIRS	40c

HEADER SCHEDULE	
(UNLESS OTHERWISE NOTED)	
SPAN	HEADER
2'-6" OR LESS	2-2x4's
4'-6" OR LESS	2-2x6's
6'-0" OR LESS	2-2x8's
7'-6" OR LESS	2-2x10's

CEILING FRAMING NOTES	
(UNLESS OTHERWISE NOTED)	
1. CEILING JOISTS - SYP #2.	
2. TYP. CEILING JOIST - 2"x6 @ 16" O.C., (U.N.O.)	
3. ALL BEAMS AND HEADERS SHALL BE SYP #2.	

DESIGN LOADS:	
LIVE LOAD	= 20 PSF.
DEAD LOAD	= 10 PSF.
WIND LOAD	= 110 MPH
	3 - SECOND GUST

NOTE:  
PROVIDE 1-1/8" WIDE 20 GA. GALV.  
STEEL STRAPS AT 32" O.C. W/10-10d  
NAILS AT THE RIDGE

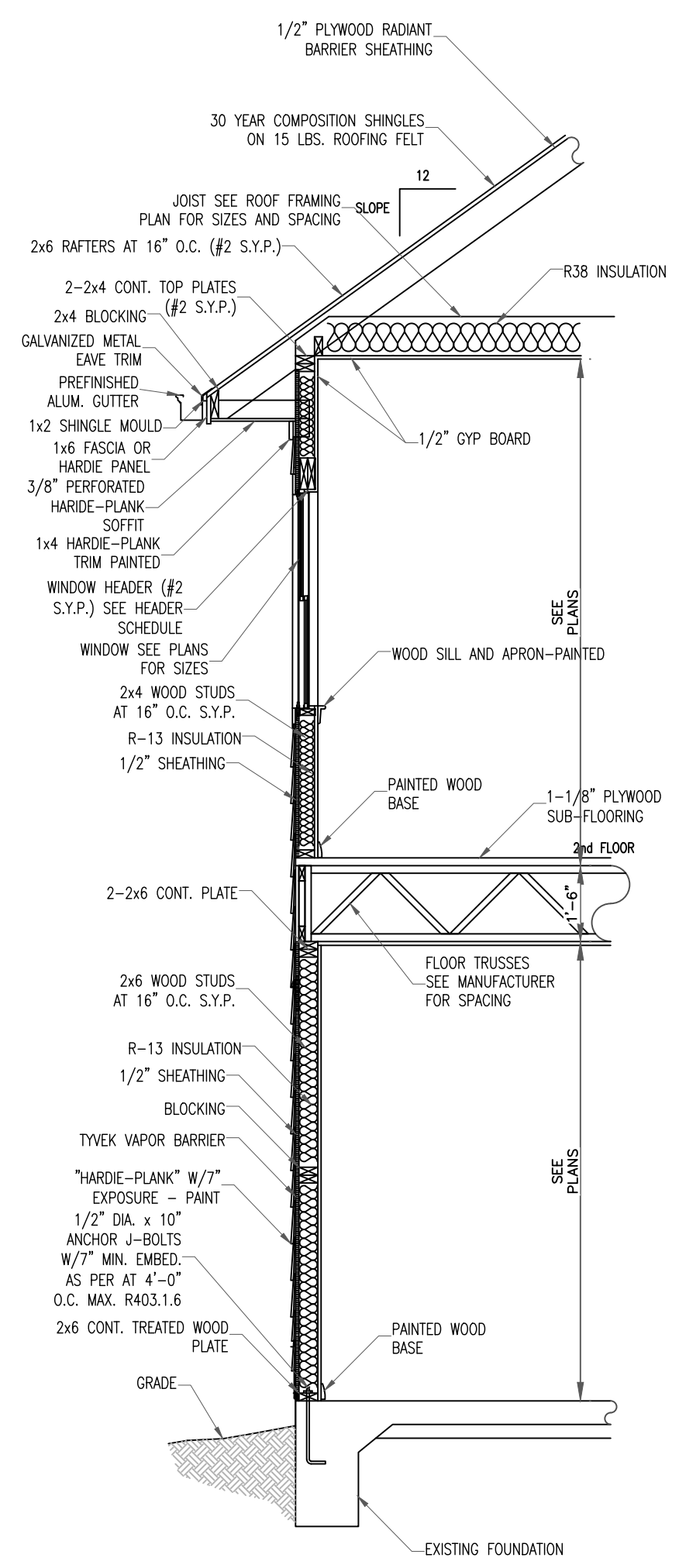

**A 2-STORY SIDING WALL SECTION**

AREA TO BE REMODELED

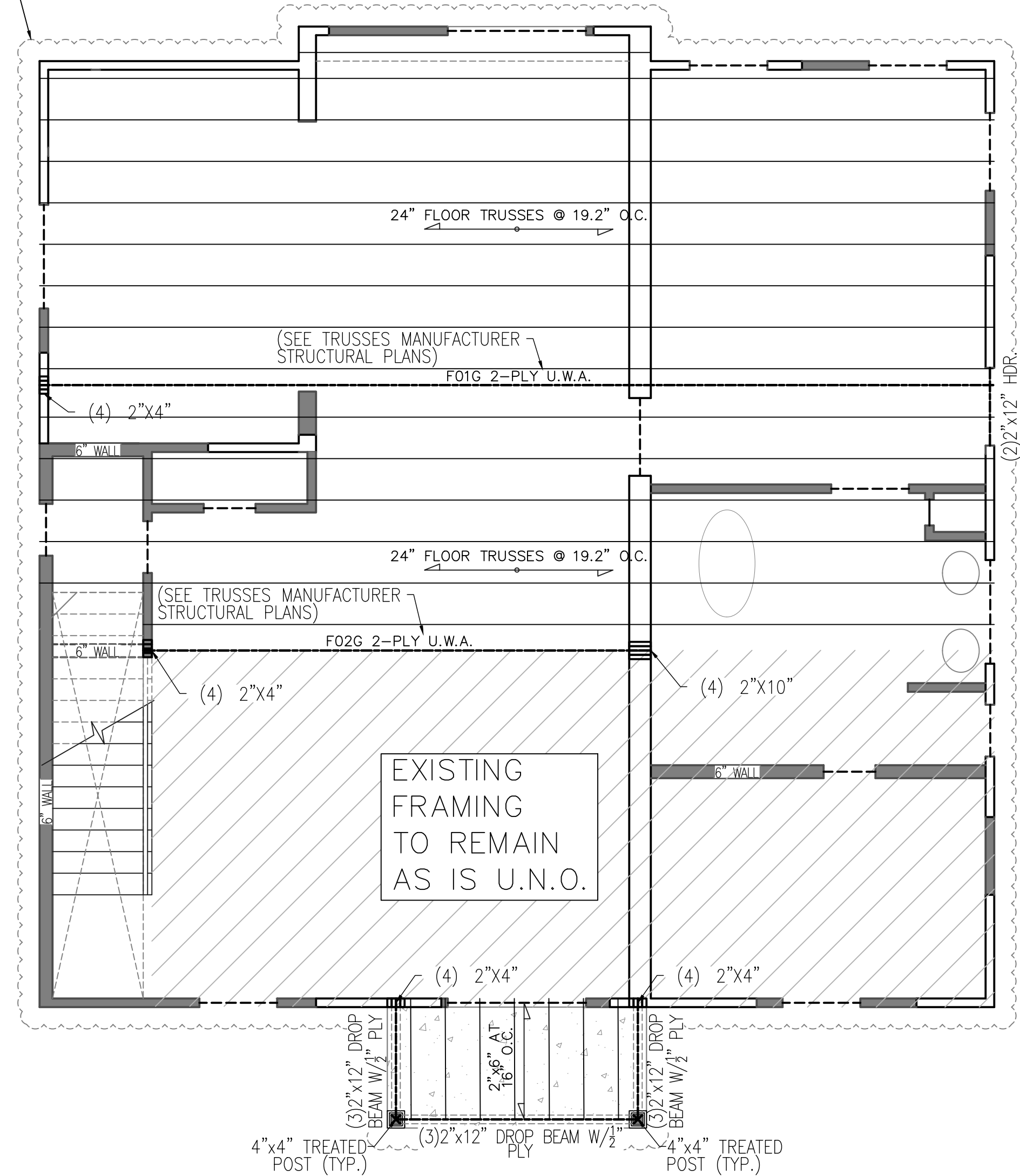

EXISTING FRAMING TO REMAIN AS IS U.N.O.

**CEILING FRAMING PLAN**

1ST. FLOOR

SCALE: 1/4"=1'-0"

**PROJECT: LDM HOMES, LLC**

**ADDRESS: 4310 APOLLO ST.**

**HOUSTON, TX 77018**

PROJECT:

ADDRESS:

**SHEET NO.**

**S2**



USE	LIVE LOAD
ATTICS W/ LIMITED STORAGE	20
ATTIC W/O STORAGE	10
DECKS	40
EXTERIOR BALCONIES	60
FIRE ESCAPES	40
GUARDRAILS AND HANDRAILS	200i
GUARDRAILS IN-FILL COMPONENTS	50i
PASSENGER VEHICLE GARAGES	50a
ROOMS OTHER THAN SLEEPING ROOMS	40
SLEEPING ROOMS	30
STAIRS	40c

HEADER SCHEDULE	
(UNLESS OTHERWISE NOTED)	
SPAN	HEADER
2'-6" OR LESS	2-2x4's
4'-6" OR LESS	2-2x6's
6'-0" OR LESS	2-2x8's
7'-6" OR LESS	2-2x10's

CEILING FRAMING NOTES	
(UNLESS OTHERWISE NOTED)	
1. CEILING JOISTS - SYP #2.	
2. TYP. CEILING JOIST - 2"x6 @ 16" O.C., (U.N.O.)	
3. ALL BEAMS AND HEADERS SHALL BE SYP #2.	

DESIGN LOADS:	
LIVE LOAD	= 20 PSF.
DEAD LOAD	= 10 PSF.
WIND LOAD	= 110 MPH 3 - SECOND GUST

NOTE:  
PROVIDE 1-1/8" WIDE 20 GA. GALV.  
STEEL STRAPS AT 32" O.C. W/10-10d  
NAILS AT THE RIDGE

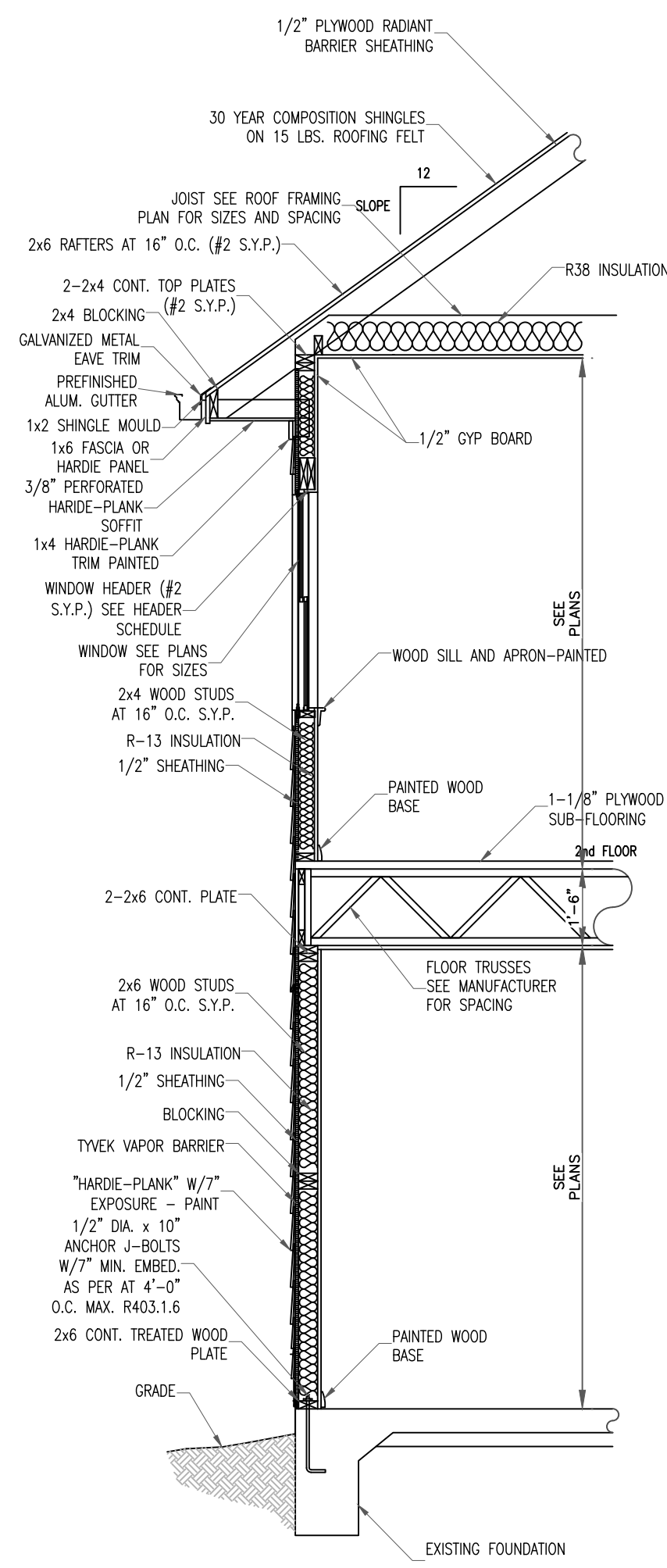

**A 2-STORY SIDING WALL SECTION**

PROPOSED ADDITION

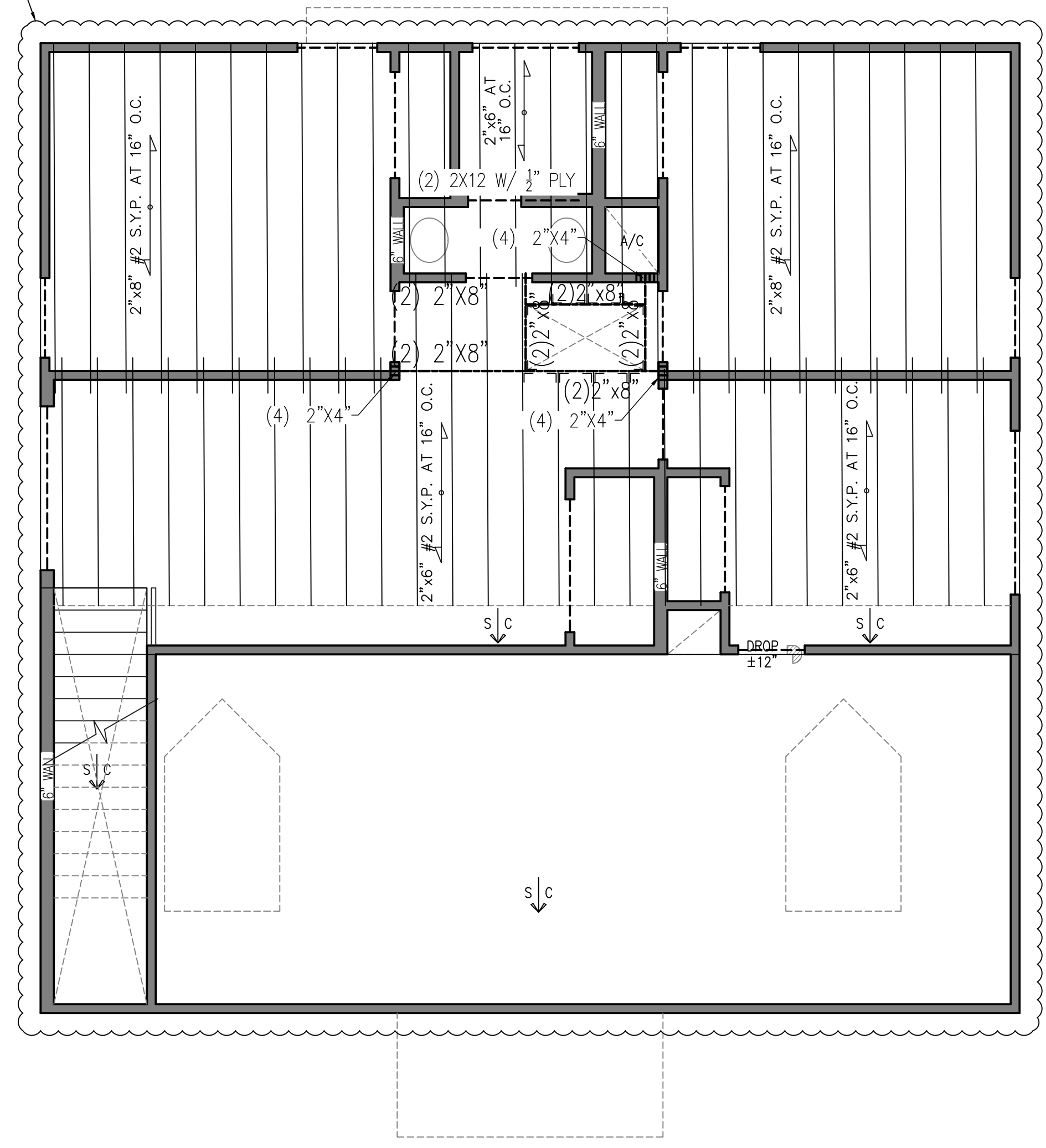

**CEILING FRAMING PLAN**  
2ND. FLOOR

SCALE: 1/4"=1'-0"

**PROJECT: LDM HOMES, LLC**

**ADDRESS: 4310 APOLLO ST.**

**HOUSTON, TX 77018**

**SHEET NO.**

**S3**



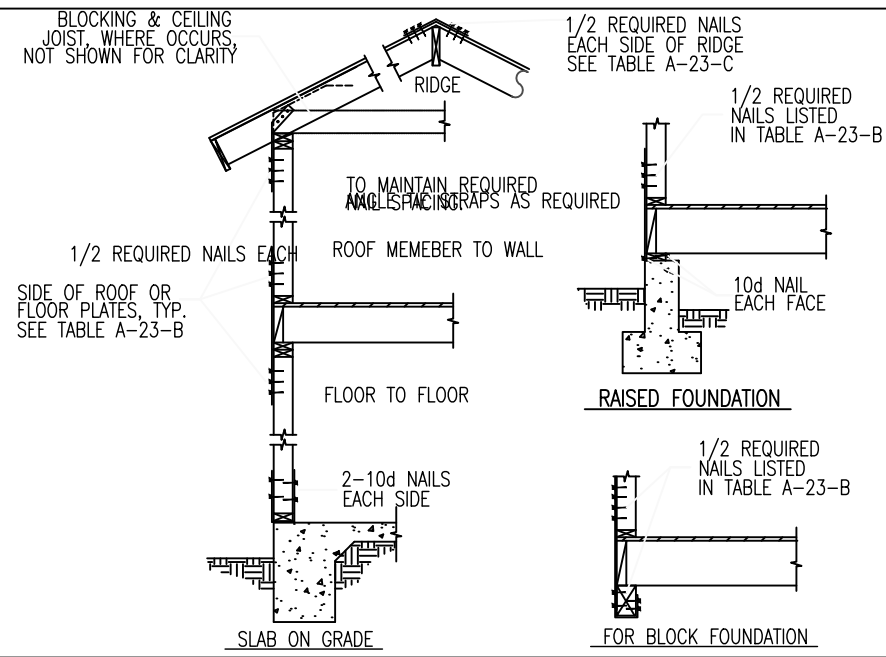

NOTE: CORROSION RESISTANT STEEL TIE STRAP 1 1/8" X 0.036" (129MM X 0.91MM) 0.036 INCH (0.91MM) (NO 20 GALVANIZED SHEET GAGE) AS 48" (1219MM) ON CENTER TYPICAL.

**DESIGN LOADS**

LIVE LOAD = 20 PSF.  
DEAD LOAD = 10 PSF.  
WIND LOAD = 110 MPH  
3 - SECOND GUST

USE	LIVE LOAD
ATTICS W/ LIMITED STORAGE	20
ATTIC W/O STORAGE	10
DECKS	40
EXTERIOR BALCONIES	60
FIRE ESCAPES	40
GUARDRAILS AND HANDRAILS	200i
GUARDRAILS IN-FILL COMPONENTS	50i
PASSENGER VEHICLE GARAGES	50a
ROOMS OTHER THAN SLEEPING ROOMS	40
SLEEPING ROOMS	30
STAIRS	40c

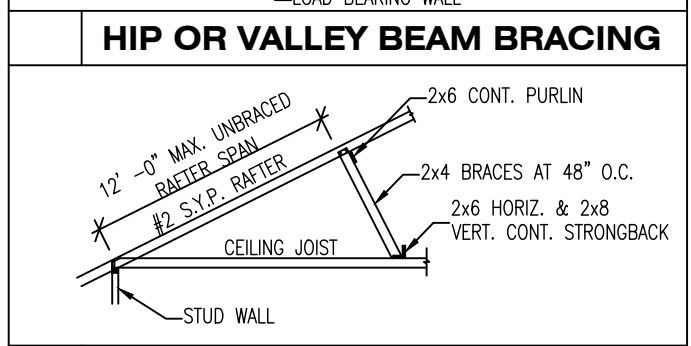
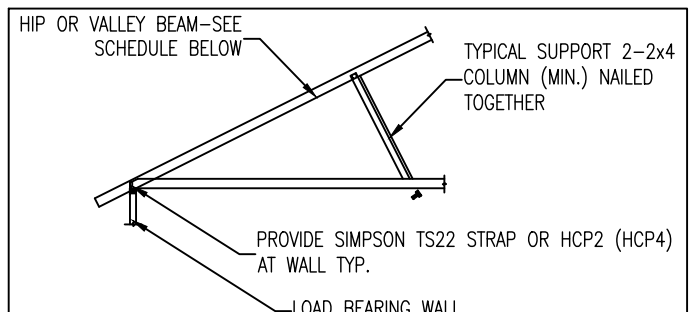

- ROOF NOTES:**
- ALL SLOPES FROM FRONT TO BACK ELEVATIONS ARE SEE PLAN / 12 PITCH AND SHALL MATCH EXISTING O.H. FROM FRAME UNLESS NOTED OTHERWISE.
  - ALL SLOPES FROM SIDE TO SIDE ELEVATIONS ARE SEE PLAN / 12 PITCH AND SHALL MATCH EXISTING OVERHANG FROM FRAME UNLESS NOTED OTHERWISE.
  - ALL RAKE OVERHANGS SHALL MATCH EXISTING FROM FINISH WALL UNLESS NOTED OTHERWISE.
  - ALL RAFTERS SHALL BE #2-2 x 6 @ 16" O.C. OR BETTER UNLESS NOTED OTHERWISE.
  - PROVIDE VALLEY FLASHING WHERE ROOF PITCHES CHANGE AND WHERE ROOF INTERSECTS WITH VERTICAL SURFACES.
  - GUTTERS AND DIVERTERS TO BE PROVIDED BY CONTRACTORS AS REQUIRED. (SEE CUSTOMER)
  - CONTRACTORS SHALL PROVIDE ADEQUATE ATTIC VENTILATION PER BUILDING CODES THROUGH CONTINUOUS SOFFIT VENTS TO RIDGE OR TURBINE VENTS. VERIFY WITH OWNER.

TABLE A-23-B ROOF AND FLOOR ANCHORAGE AT EXTERIOR WALLS

BASIC WIND SPEED X 1.81 FOR KNOTS	LOCATION	NUMBER OF NAILS		
		B	C	D
80	ROOF TO WALL	6-8d	8-8d	8-10d
	FLOOR TO FLOOR	---	4-10d	6-10d
	FLOOR TO FOUNDATION	---	4-10d	4-10d
90	ROOF TO WALL	8-8d	8-10d	10-10d
	FLOOR TO FLOOR	---	6-10d	8-10d
	FLOOR TO FOUNDATION	---	4-10d	6-10d
100	ROOF TO WALL	8-10d	10-10d	12-10d
	FLOOR TO FLOOR	6-10d	8-10d	10-10d
	FLOOR TO FOUNDATION	4-10d	6-10d	8-10d
110	ROOF TO WALL	10-10d	12-10d	12-10d
	FLOOR TO FLOOR	8-10d	10-10d	10-10d
	FLOOR TO FOUNDATION	6-10d	8-10d	8-10d

FIGURE A-23-1 COMPLETE LOAD PATH DETAILS

FOR FLOOR TO FOUNDATION ANCHORAGE, SEE SECTION 2365.5.4 NUMBER OF COMMON NAILS LISTED IS TOTAL REQUIRED FOR EACH TIE STRAP. THE TIE STRAPS SHALL BE SPACED AT 48" ON CENTER ALONG THE LENGTH OF THE WALL. THE NUMBER OF NAILS ON EACH SIDE OF THE ROOF OR FLOOR PLATE JOINTS SHALL BE EQUAL. NAILS SHALL BE SPACED TO AVOID SPLITTING THE WOOD, SEE FIGURES A-23-1 FOR ILLUSTRATIONS OF THESE TIE STRAPS.

- NOTE:**
- PROVIDE 2 x 6 PURLIN BRACING WITH 2 x 4 "I" COLUMN MINIMUM BRACED BACK TO LOAD BEARING WALL OR FLOAT BEAM.
  - PROVIDE 2 x 6 COLLAR BEAMS @ EVERY OTHER RAFTER @ 3' TO 4' BELOW RIDGE LINE.
  - RIDGE, HIP, AND VALLEY RAFTERS TO BE NEXT SIZE LARGER THAN CONNECTING MEMBER.

**NOTE:**

ALL NEW RAFTERS 2x6 @ 16" O.C.  
SYP. #2 GRADE OR BETTER (U.N.O.)

COORDINATE ALL DIMENSIONS, RECESS AND DROPS W/ ARCHITECTURAL DWGS

TABLE A-23-C RIDGE TIE-STRAP NAILING

BASIC WIND SPEED X 1.81 FOR KNOTS	NUMBER OF NAILS		
	B	C	D
80	6-10d	8-10d	10-10d
90	8-10d	10-10d	12-10d
100	10-10d	12-10d	14-10d
110	12-10d	14-10d	16-10d

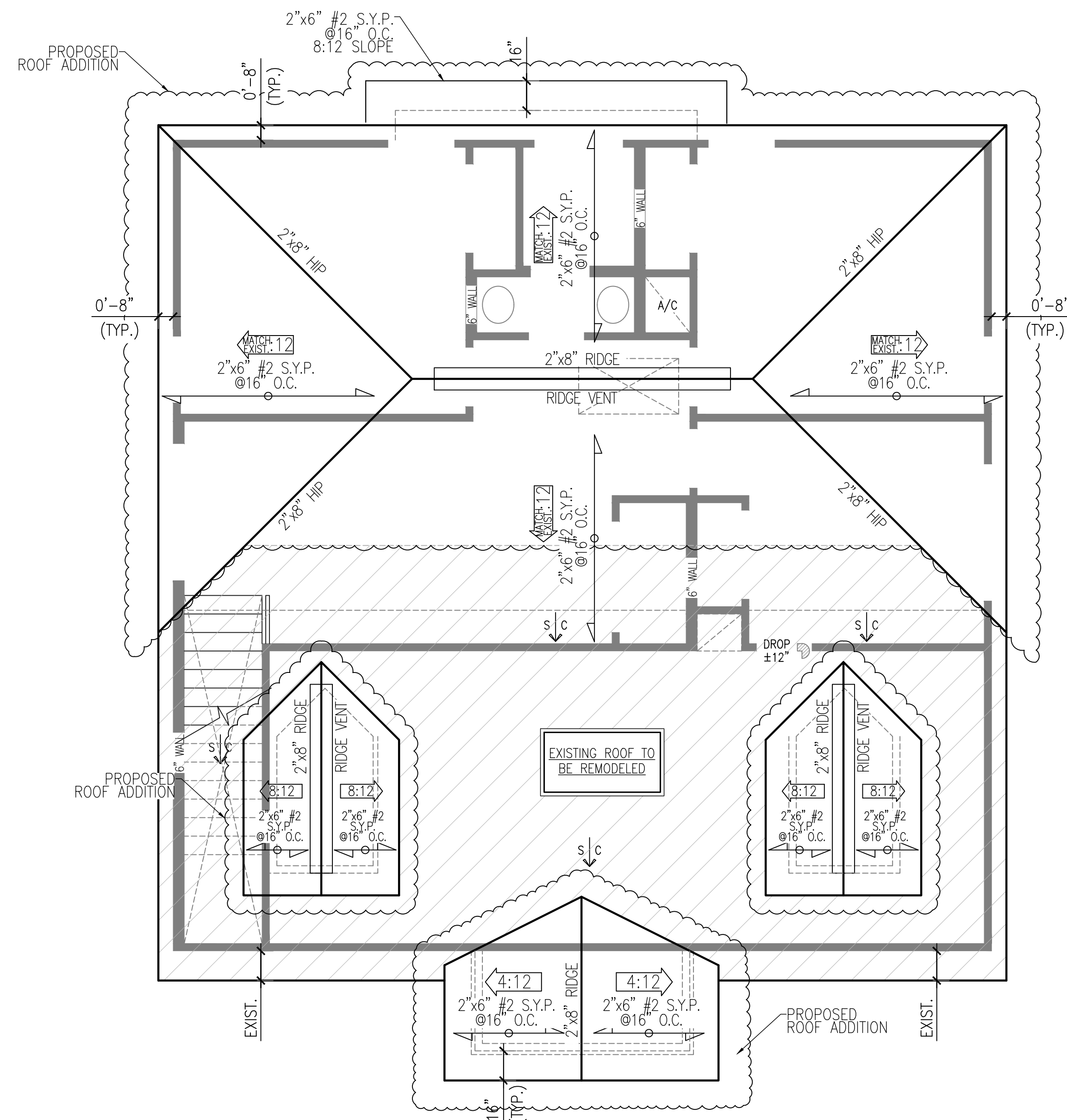

**3h Engineering & Construction, Inc**

TBPE FIRM NO. F-18626  
2500 East TC Jester, Suite 180  
Houston, Texas 77008

info@3h.engineering  
p. 281-819-3150

Jose A. Rocha  
5/27/21

**PROJECT:** LDM HOMES, LLC

**ADDRESS:** 4310 APOLLO ST.  
HOUSTON, TX 77018

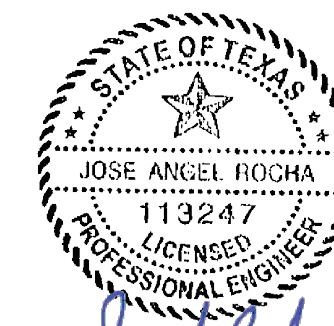

*Jose A. Rocha*  
5/27/21

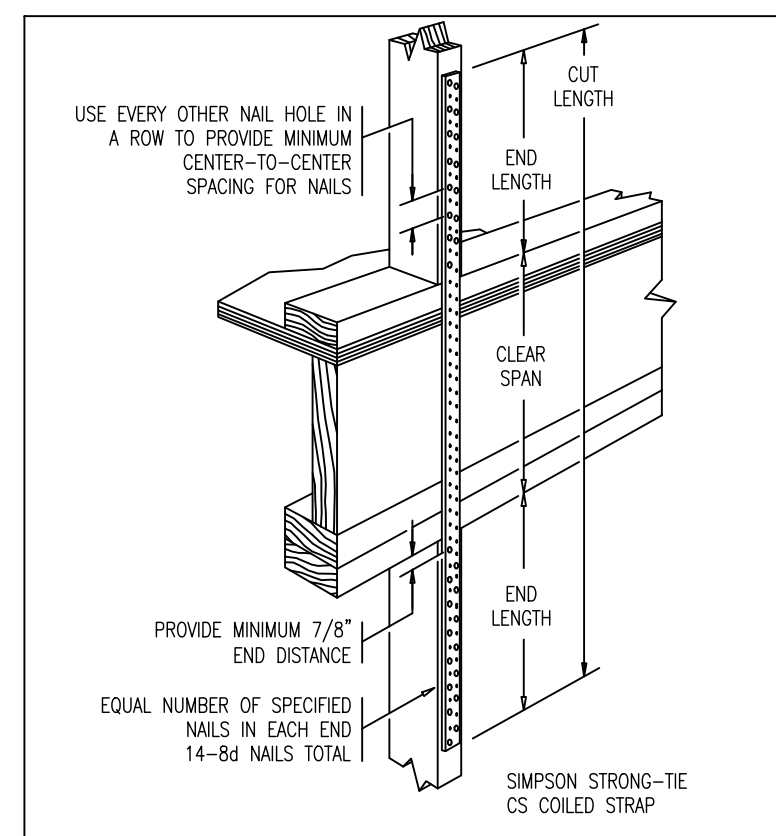
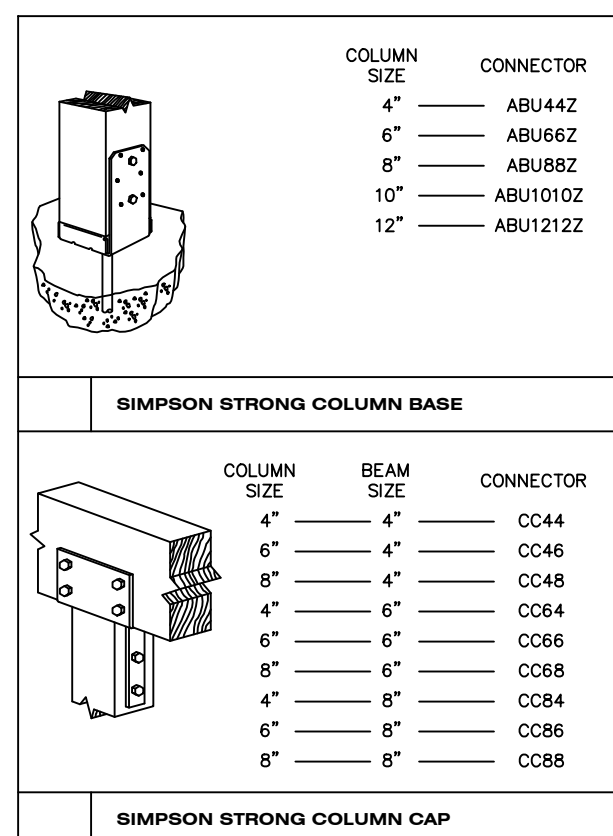
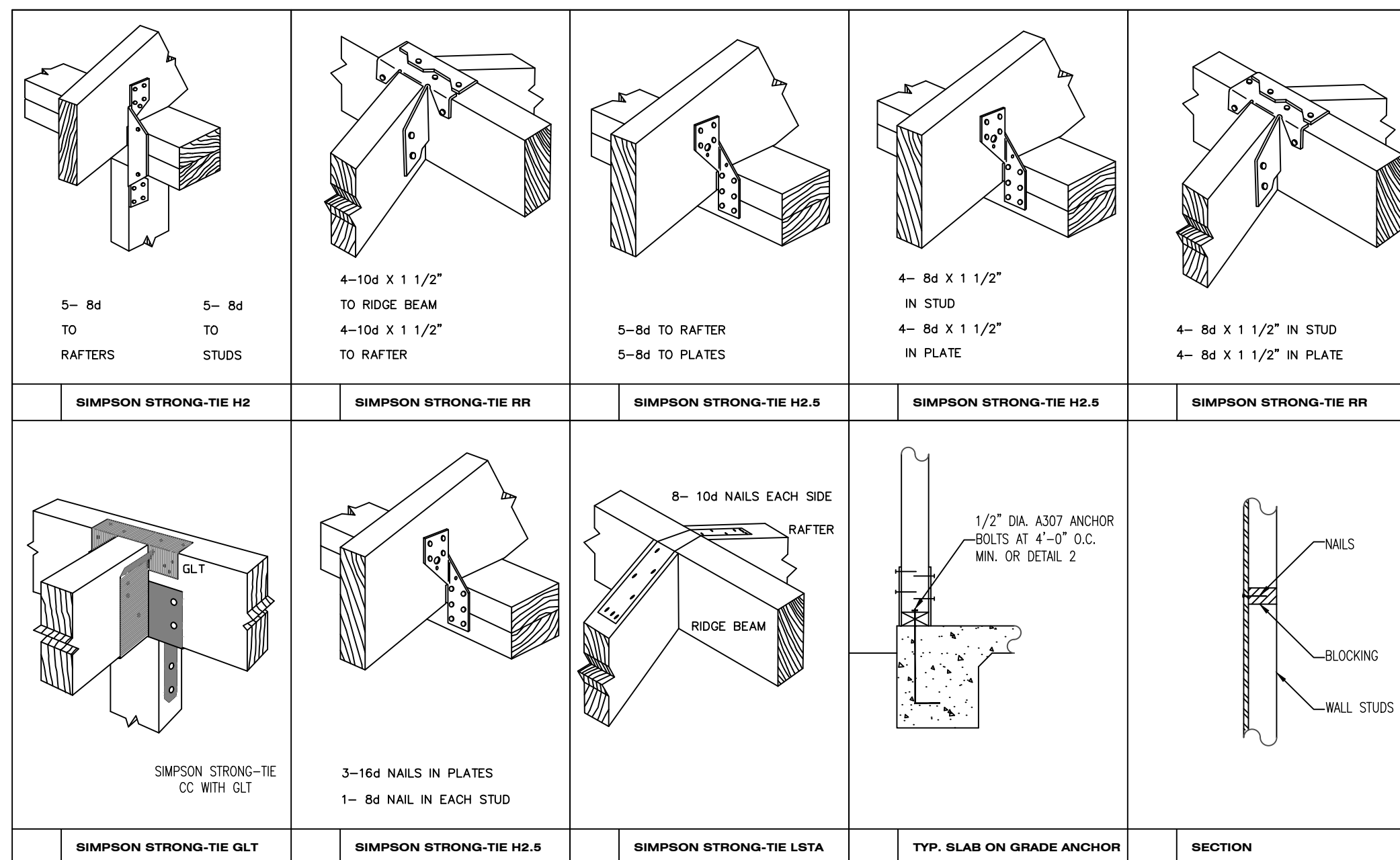

**DESIGN LOADS:**

LIVE LOAD = 20 PSF.  
DEAD LOAD = 10 PSF.  
WIND LOAD = 110 MPH  
3 - SECOND GUST

**NOTES:**

1. INSTALL HURRICANE STRAPS PER DETAILS D1 THRU D4 FOR STRAPS FOR MATCHING RAFTERS SEE D5.
2. WHERE RAFTERS ARE STAGGERED USE DETAIL RR ON D2.
3. WHERE RAFTERS AND STUDS MATCH USE DETAIL H2 ON D1.
4. WHERE STUD MATCH FROM THE FIRST FLOOR TO THE SECOND FLOOR USE CS ON D1.
5. WHERE RAFTERS DO NOT MATCH TO STUDS USE H2 ON D2.
6. TO TIE STUDS TO TOP PLATE WHERE RAFTERS DO NOT MATCH USE RSP4 ON D3.
7. CONNECT STUDS TO BOTTOM PLATE PER RSP4 ON D3.
8. ALL WALLS SHALL HAVE DIAGONAL BRACING PER WW ON D4. ALTERNATE BRACING IS 1X4 LET-IN FROM TOP PLATE TO BOTTOM PLATE.
- 9.

**FASTENER SCHEDULE FOR STRUCTURAL MEMBERS**  
**TABLE R602.3(1)**

DESCRIPTION OF BUILDING ELEMENTS	NUMBER & TYPE OF FASTENER a,b,c,d	SPACING OF FASTENERS
Joist to sill or girder, toe nail	3-8d	-
1"x6" subfloor or less to each joist, face nail	2-8d 2 staples, 1-3/4	-
2" subfloor to joist or girder, blind & face nail	2-16d	-
Sole plate to joist or blocking, face nail	16d	16" O.C.
Top or sole plate to stud, end nail	2-16d	-
Stud to sole plate, toe nail	4-8d or 2-16d	-
Double studs, face nail	16d	24" O.C.
Double top plates, face nail	16d	16" O.C.
Sole plate to joist or blocking at braced wall panels	3-16d	16" O.C.
Double top plates, minimum 48" offset of end joints, face nail in lapped area	8-16d	-
Blocking between joists or rafters to top plate, toe nail	3-8d	-
Rim joist to top plate, toe nail	8d	6" O.C.
Top plates, laps at corners & intersections, face nail	2-10d	-
Built-up header, two pieces with 1/2" spacer	16d	16" O.C. along each edge
Continued header, two pieces	16d	16" O.C. along each edge
Ceiling joists to plate, toe nail	3-8d	-
Continuous header to stud, toe nail	4-8d	-
Ceiling joist, laps over partitions, face nail	3-16d	-
Ceiling joist to parallel rafters, face nail	3-10d	-
Rafter to plate, toe nail	3-8d	-
1" brace to each stud & plate, face nail	2-8d 2 staples, 1-3/4	-
1"x6" sheathing to each bearing, face nail	2-8d 2 staples, 1-3/4	-
1"x8" sheathing to each bearing, face nail	3 staples, 1-3/4	-
Wider than 1"x8" sheathing to each bearing, face nail	3-8d 4 staples, 1-3/4	-
Built-up corner studs	16d	24" O.C.
Built-up girders & beams, 2-inch lumber layers	20d	Nail each layer as follows: 32" O.C. at top & bottom & staggered. Two nails at ends & at each splice
2" planks	2-16d	At each bearing
Roof rafters to ridge, valley or hip rafters: toe nail	4-16d	-
face nail	3-10d	-
Rafter ties to rafters, face	3-8d	-
Wood structural panels, subfloor, roof & wall sheathing to framing, & particleboard wall sheathing to framing		
5/16 - 1/2	6d common nail (subfloor, wall) 8d common nail (roof)	6      12 <sup>9</sup>
19/32 - 1	8d common nail	6      12 <sup>9</sup>
1-1/8 - 1-1/4	10d common nail or 8d deformed nail	6      12

**BRACING DETAILS**

SCALE: N.T.S.

**NAILING DETAILS**

SCALE: N.T.S.

**PROJECT:** LDM HOMES, LLC

**ADDRESS:** 4310 APOLLO ST.  
HOUSTON, TX 77018

**SHEET NO.**

**S5**



**FLOOR FRAMING NOTES:**

- FLOOR JOIST - SYP #2
- TYP. FLOOR JOIST - 2X12 @ 16" O.C. U.N.O.
- TYP. SHEATHING - 1 1/8" 48/24 APA RATED T & G GLUED & NAILED W/10 D @ 6" EDGES & 10" FIELD
- ALL BEAMS AND HEADERS SHALL BE SYP #2
- PROVIDE 2- 2X12 HEADERS AT ALL FIRST LEVEL OPENINGS U.N.O.
- DOUBLE JOIST UNDER ALL NON LOAD-BEARING PARTITIONS
- ALL FLUSH BEAM - TO - BEAM CONNECTIONS SHALL BE SIMPSON HGB OR HGLT (U.N.O.)
- DL = 10 PSF LL = 40 PSF

**CEILING FRAMING NOTES**

- CEILING JOISTS - SYP #2
- TYP. CEILING JOIST - 2X6 @ 16" O.C. U.N.O.
- ALL BEAMS AND HEADERS SHALL BE SYP #2
- HEADER SCHEDULE:

SPAN	HEADER
2'-6"	2 - 2x4
4'-6"	2 - 2x6
6'-0"	2 - 2X8
7'-6"	2 - 2X10

- ALL FLUSH BEAM - TO - BEAM CONNECTIONS SHALL BE SIMPSON HGB OR HGLT (U.N.O.)
- DL = 10 PSF LL = 20 PSF

**GENERAL NOTE**

FRAMING DESIGN CRITERIA BASED ON 2017 NFPA SPAN TABLES FOR JOISTS AND RAFTERS, AND SPIB GRADING RULES. VERIFY ALL DIMENSIONS, DROPS, OFFSETS, BRICKLEDGES, INSERTS AND OPENINGS WITH ARCHITECTURAL DRAWINGS.

**STUD WALL FRAMING NOTE**

FRAME EXTERIOR LOAD-BEARING STUD WALLS WITH UNBRACED HEIGHT GREATER THAN 10'-0" WITH 2X6 STUDS @ 16" O.C.

FRAME INTERIOR LOAD-BEARING STUD WALLS WITH UNBRACED HEIGHT GREATER THAN 10'-0" WITH 2 - 2x4 STUDS @ 16" O.C. OR 2X6 STUDS @ 16" O.C.

STUD WALLS SHALL BE DIAGONALLY BRACED W/ 1 X 4 LET-IN AT EACH END, AT 25" MAX. SPACING BETWEEN WALL STRAP TIES MST @ SECOND FLOOR AND ROOF, SPACED @ 32" O.C. H3 CONNECTORS AT SILL PLATE @ 16" O.C. ENDS.

**GENERAL FRAMING NOTES**

- HIP, VALLEY, AND RIDGE SHALL ALWAYS BE ONE SIZE LARGER THAN RAFTERS.
- PROVIDE COLLAR TIES AT UPPER 1/3 DISTANCE BETWEEN RIDGE BOARD AND JOIST AT 32" O.C.
- ALL RAFTERS 2X6 AT 16" O.C. UNLESS OTHERWISE NOTED.
- DOUBLE FLOOR JOIST UNDER ALL PARTITIONS PARALLEL TO JOIST BELOW.
- PROVIDE CROSSBRIDGING AT 8'-0" O.C. ON ALL 2X12 JOISTS.
- PROVIDE RAFTER TIES AT ALL PLATES WHERE JOIST ARE PERPENDICULAR TO RAFTERS.
- PROVIDE 2- 2X6 STRONGBACK ON SPANS OVER 10'-0".
- ALL STRUCTURAL FRAMING SHALL HAVE A 19% MAXIMUM MOISTURE CONTENT AT TIME OF INSTALLATION.
- STUD WALLS EXCEEDING 10'-0" SHALL HAVE FIRESTOPS SHALL BE 10'-7". RAFTERS ARE TO BE SUPPORTED BY CONTINUOUS 2 X 6 BRACES AT 48" O.C. MAXIMUM ANGLE FOR 2 X 6 BRACES = 45 DEG FROM VERT. MAXIMUM UNSUPPORTED LENGTH FOR 2 X 6 BRACES = 8'. ALL ROOF BRACING TO BE SUPPORTED BY A WALL 2-2 X 6 STRONGBACK SUPPORTED BY JOISTS OR (2) 2 X 12 DEPENDING ON CEILING JOIST DIRECTION (PROVIDE BLOCKING AT BRACE LOCATIONS), (U.N.O.) PROVIDE 2 X 6 COLLAR TIES 48" O.C. IN THE UPPER THIRD OF THE RAFTERS, (U.N.O.).
- PROVIDE 26 GA. GALVANIZED IRON FLASHING AT ALL VALLEYS, HIPS, AND RIDGES WHERE APPLICABLE. ALSO APPLY FOR PIPES PROJECTING THROUGH ROOF WITH FLANGE AND EXTEND FLANGE 8" BEYOND SLEEVE.
- ALL BEAM AND HEADER MATERIAL SHALL BE #2 SD19 SYP. ALL RAFTERS AND JOIST MATERIAL SHALL BE #2 SD19 SYP.
- ALL WALL STUD SHALL BE STUD GRADE SD19 FIR 16" O.C.
- ALL STEEL SHALL CONFORM TO ASTM A-36.
- ROOF LIVE LOAD = 20 PSF, SECOND FLOOR LIVE LOAD = 40 PSF, CEILING LIVE LOAD = 10 PSF, WIND LOAD 110 MPH
- ROOF DECKING SHALL BE 1/2" EXPOSURE 1 (CDX) OR WAFERBOARD APA RATED SHEATHING (24/0). SECOND FLOOR DECKING SHALL BE APA 1 1/8 PLYWOOD OR 2X6 T & G INSTALLED DIAGONALLY.
- FRAMING CONNECTORS SHALL BE SIMPSON STRONG-TIE MTS12 @ 32" O.C.

- CORNER SHEATHING (FROM CORNER TO A DISTANCE 8'-0" FROM CORNER) PROVIDE 1/2" PLYWOOD SHEATHING. BLOCK ALL UNSUPPORTED EDGES OF SHEATHING. NAIL W/ 8d NAILS AT 4" O.C. EDGES, 12" O.C. FIELD.
- ALL EXTERIOR WALL TO USE 1/2" O.S.B. (MIN) NAIL 4" O.C. AT EDGES, & 12" O.C. AT FIELD W/8d NAILS TYP. (U.N.O.)
- INSTALLATION: DRIVE NAILS FLUSH. DO NOT PENETRATE THE SURFACE OF THE SHEATHING.

**WIND STORM NOTES:**

- RAFTER HURRICANE TIES - CONNECT ALTERNATE RAFTERS TO SUPPORTS WITH SIMPSON H2.5 HURRICANE TIE
- ALIGN OPPOSING RAFTERS @ RIDGE AND CONNECT WITH SIMPSON LSTA STRAPS TIE WITH 10-10d NAILS (5 EA. SIDE)
- ROOF BRACING - 2 X 6 PURLIN WITH 2 X 4 BRACE @ 48" O.C. TO BEAM OR WALL BELOW
- ALL BEAM CONNECTIONS SIMPSON HGB OR HGLT
- PROVIDE FULL BEARING UNDER BEAMS CONTINUOUSLY TO FOUNDATION
- DL - 5 PSF LL 10 PSF UNIFORM DIST. LOAD FROM WALL ABOVE #/LF POINT LOAD FROM WALL OR COLUMN ABOVE # ALL NON LOAD BEARING TRUSSES @ 120 #/LF MIN. PLUS LOAD FROM WALL ABOVE ALL FLUSH BEAM CONNECTIONS SIMPSON HGB OR HGLT ALL FLUSH STEEL TO STEEL BEAMS CONNECTIONS 2- L 4" X 4" X 1/4" X 9' WITH 6- 3/4" # A307 BOLTS

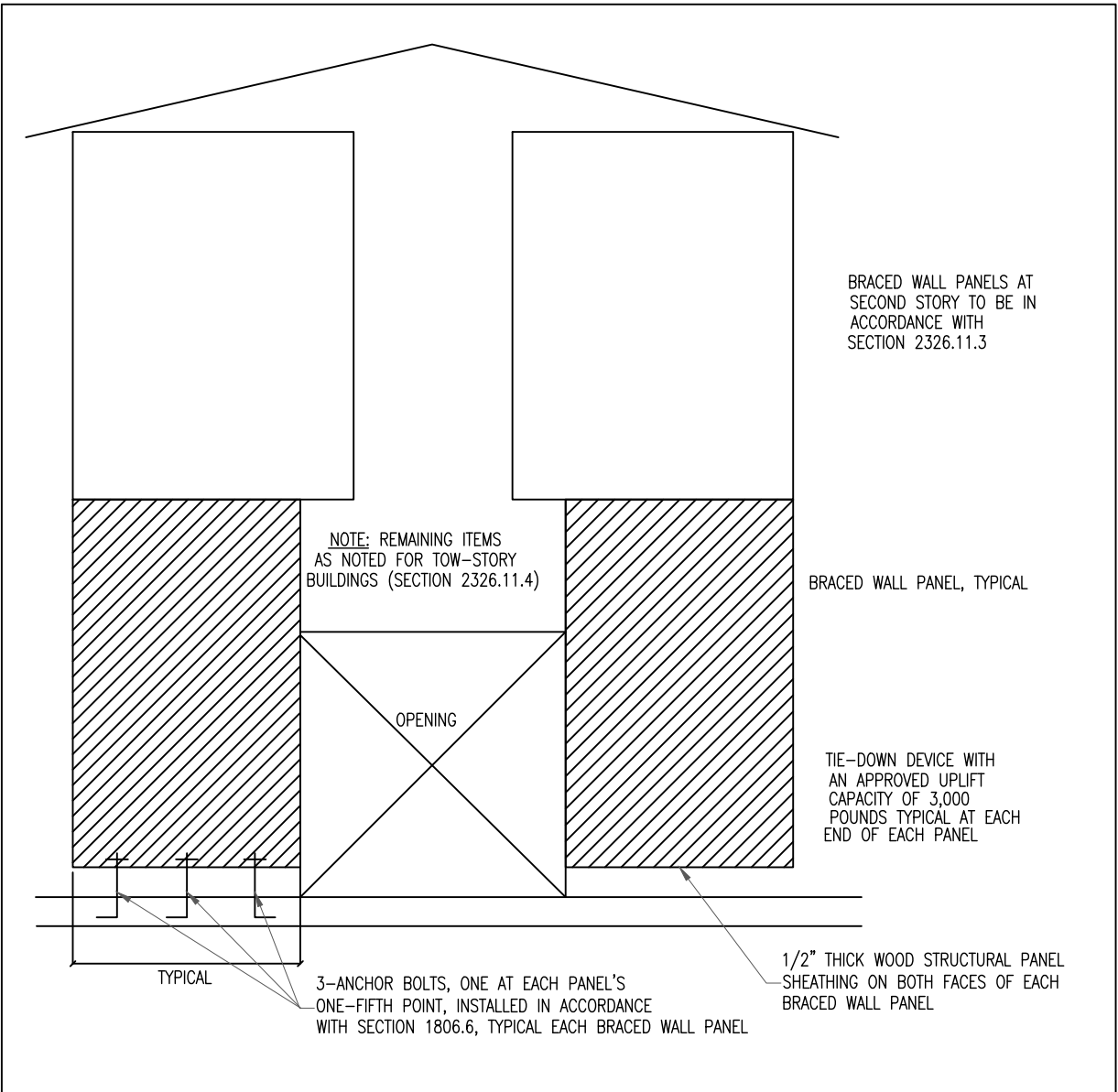
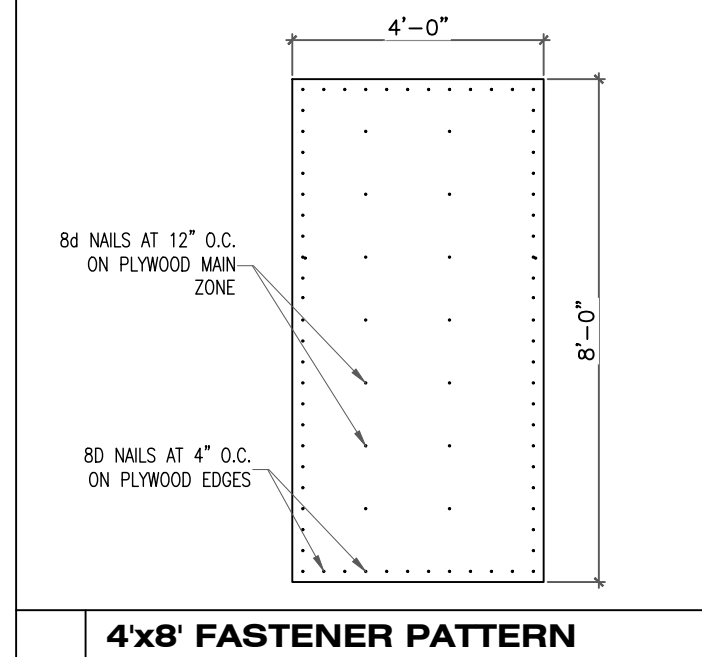

**DETAIL FOR SHEAR WALL PANEL**

**NOTES:**

- ALL EXTERIOR CORNER WALLS SHALL HAVE A MINIMUM OF ONE LAYER OF 1/2" PLYWOOD SHEATHING (STRUCTURAL GRADE) WITH 8d NAILS @ 4" O.C.
- SEE DETAIL FOR SHEAR WALLS. PROVIDE THE SHEATHING/NAILING PATTERN AS INDICATED ON THESE DRAWINGS.
- 1/2" DRYWALL WITH 5d COOLER NAILS @ 7" O.C. AT EDGES PROVIDE THIS AS STANDARD CONSTRUCTION FOR BOTH SIDES OF ALL INTERIOR STUD WALLS.
- PROVIDE BLOCKING AT ALL SHEATHING EDGES. PROVIDE DOUBLE STUDS W/ SIMPSON HTS AT EACH END OF THE SHEAR WALL.
- PROVIDE 1/2" ANCHOR BOLTS @ 4'-0" MAX. OR AT LEAST 2 BOLTS IN THE MIDDLE OF EACH SHEAR WALL WITH 7 INCHES OF EMBEDMENT
- PROVIDE CONTINUOUS HURRICANE CLIPS FROM ROOF TO FOUNDATION AS REQUIRED BY LOCAL BUILDING CODE.
- PROVIDE ONE LAYER OF 1/2" OSB SHEATHING (STRUCTURAL GRADE) AT A MAXIMUM DISTANCE OF 25'-0" ON ALL EXTERIOR WALLS.

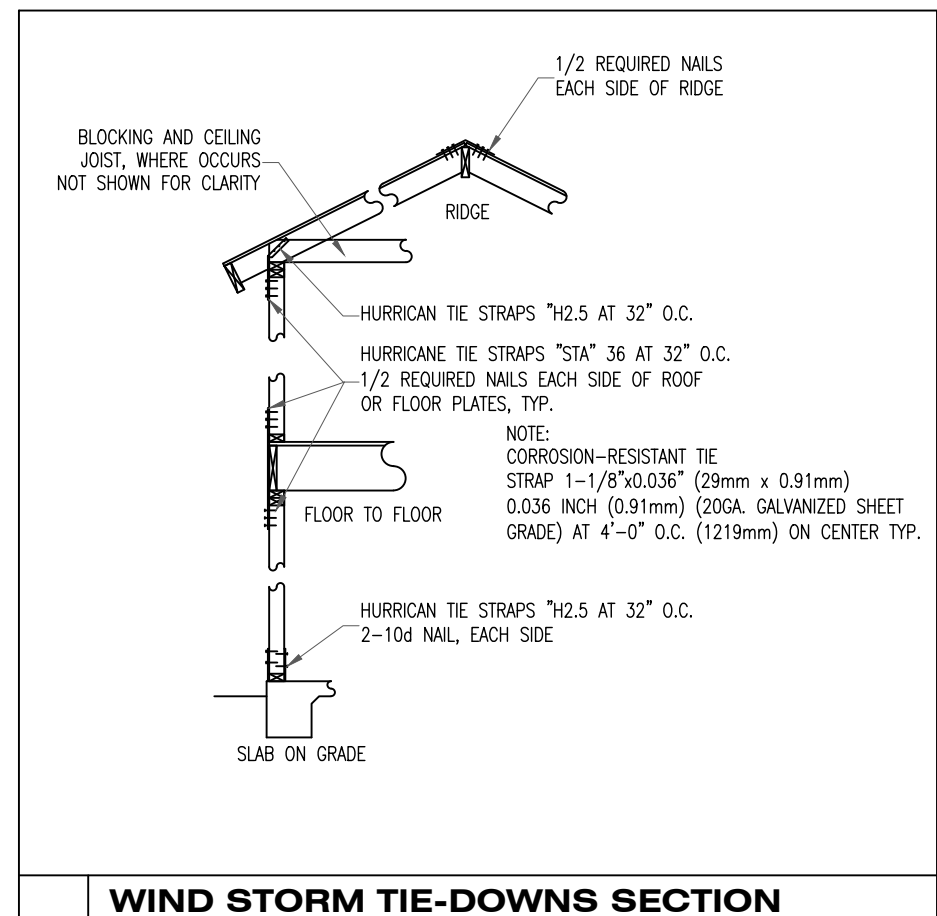

**BEAMS:**

(IF APPLICABLE) STEEL FLITCH BEAMS BE CONSTRUCTED WITH TWO ROWS OF 1/2" DIAM. BOLTS SPACED AT 24" O/C AND STAGGERED TOP AND BOTTOM (PROVIDE (2) BOLTS AT EACH END OF BEAM). HOLES SHALL BE 9/16" Ø AND DRILLED. EDGE CLEARANCE SHALL BE 1 1/2" FOR ALL BOLTS. WHEN ONE FLITCH BEAM IS "TEED" INTO ANOTHER THE BEAM SHALL BE SUPPORTED BY A SIMPSON EG5 HANGER. EDGE CLEARANCE SHALL BE 1-1/2" FOR ALL BOLTS. WOOD SHALL BE #2 KD 19 AND BOTH STEEL AND WOOD SHALL BE CONTINUOUS.

TRIPLE SECOND FLOOR JOISTS UNDER PARTITION WALLS ABOVE (U.N.O.). ALL JOISTS FRAMING TO BEAMS SHALL BE SUPPORTED BY SIMPSON U JOIST METAL HANGERS (U.N.O.). ALL BEAMS FRAMING TO BEAMS SHALL BE SUPPORTED BY SIMPSON B/HB METAL HANGERS (U.N.O.). ALL BEAMS FRAMING TO WALLS ARE TO BE SUPPORTED BY A MINIMUM OF (2) 2 X 4 OR (2) 2 X 6 STUDS UNLESS OTHERWISE NOTED.

HEADER SCHEDULE AS FOLLOWS (USE (2) 2 X 12'S WITH 1/2" PLYWOOD (U.N.O.) FOR FIRST FLOOR HEADERS):

SIZE	MAXIMUM SPAN	SIZE	MAXIMUM SPAN
2-2 X 6	4' - 6"	2-2 X 10	7' - 6"
2-2 X 8	6' - 0"	2-2 X 12	9' - 0"

THE NUMBER AND SIZE OF NAILS USED TO CONNECT WOOD MEMBERS SHALL BE ACCORDING TO TABLE 250 OF THE HOUSTON/UBC BUILDING CODE IS APPLICABLE (U.N.O.). MULTIPLE STUDS SHALL BE GLUED AND NAILED WITH 10d NAILS 24" O.C. MULTIPLE JOISTS SHALL BE GLUED AND NAILED WITH 3-16d NAILS 12" O.C. THERE SHALL BE NO SPLICES.

STUD WALLS 14" OR HIGHER SHALL HAVE 2 X 6, (2) 2 X 4 OR 4 X 4 STUDS AT 16" O.C. WALLS SUPPORTING TWO FLOORS ABOVE SHALL BE 2 X 6, (2) 2 X 4 OR 4 X 4 STUDS AT 16" O.C.

GLUED LAM. BEAMS TO BE SOUTHERN PINE AND INSTALLED PER THE AMERICAN INSTITUTE OF TIMBER CONSTRUCTION. FY = 2400 PSI, FV = 165 PSI, E = 1,800 PSI.

CONTRACTOR/OWNER SHALL VERIFY FIELD DIMENSIONS AND DETAILS, NOTIFY THE PROJECT ARCHITECT/ENGINEER OF ANY DISCREPANCY FOR REVIEW RECOMMENDATIONS AND REVIEW RECOMMENDATIONS AND REVISE THEM, IF NECESSARY. ALL CONSTRUCTION PROCEDURES SHALL CONFORM TO LOCAL CODES AND OSHA GUIDELINES.

(1) ADJUST TO COMPLY WITH MAX. DISTANCE OF 25'-0" O.C.

**SHEAR WALL SCHEDULE**

TYPE	SHEATHING / NAILING PATTERN
1	(1) LAYER OF 1/2" STRUCTURAL PLYWOOD w/ 8d NAILS @ 4" O.C. AT ALL EDGES (10 USE)
2	(1) LAYER OF 1/2" STRUCTURAL PLYWOOD w/ 8d NAILS @ 2.5" O.C. AT ALL EDGES
3	(2) LAYER OF 1/2" STRUCTURAL PLYWOOD w/ 10d NAILS @ 4" O.C. AT ALL EDGES
4	(2) LAYER OF 1/2" STRUCTURAL PLYWOOD w/ 10d NAILS @ 2.5" O.C. AT ALL EDGES
5	SEE DETAIL FOR SHEAR WALL #5
6	SEE DETAIL FOR SHEAR WALL #6

**RIIDGE TIE-STRAP NAILING**

BASIC WIND SPEED (MPH)	NUMBER OF NAILS EXPOSURE		
	B	C	D
x 1.61 FOR KPH			
110	12-10d	14-10d	16-10d

**ROOF AND FLOOR ANCHORAGE AT EXTERIOR WALLS**

BASIC WIND SPEED (MPH)	LOCATION	NUMBER OF NAILS		
		B	C	D
x 1.61 FOR KPH				
110	ROOF TO WALL	10-10d	12-10d	12-10d
	FLOOR TO FLOOR	8-10d	10-10d	10-10d
	FLOOR TO FOUNDATION	6-10d	8-10d	8-10d

**GENERAL NOTES**

SCALE: N.T.S.

**LDM HOMES, LLC**

4310 APOLLO ST.

HOUSTON, TX 77018

PROJECT:

ADDRESS:

**SHEET NO.**