

FOUNDATION NOTES

- GENERAL NOTES:
 - THESE NOTES SHALL APPLY TO THE STRUCTURAL DRAWINGS (U.N.O.).
 - ALL DETAILS OF DESIGN, WORKMANSHIP AND MATERIALS SHALL CONFORM TO THE 2012 INTERNATIONAL RESIDENTIAL BUILDING CODE (I.R.B.C.).
 - GRAVITY LOADS:
FIRST FLOOR CEILING FRAMING: DL = 10 PSF LL = 40 PSF
SECOND FLOOR CEILING FRAMING: DL = 10 PSF LL = 20 PSF
WIND SPEED = 110 MPH, 3 SECOND GUST
- DESIGN:
 - THIS FOUNDATION IS DESIGNED IN ACCORDANCE WITH CURRENT ACCEPTABLE ENGINEERING PRACTICES FOR THE SITE SHOWN ON THE PLANS AND MAY NOT BE USED IN ANY OTHER LOCATION.
 - THIS DESIGN DOES NOT ALLOW FOR IMPROPER DRAINAGE, TREES LOCATED TO CLOSE TO THE FOUNDATION OR IMPROPER MAINTENANCE.
- SITE WORK:
 - PLACE SOIL IN COMPLIANCE WITH GEOTECHNICAL ENGINEERS SITE PREPARATION RECOMMENDATIONS.
 - FINAL GRADE AT EXTERIOR BEAMS SHALL BE COMPLETED WITH NATURAL CLAY MATERIALS, NO SAND SHALL BE ALLOWED, SLOPE GRADE AWAY FROM FOUNDATION ONE INCH PER FOOT FOR THE FIRST FIVE FEET AND SIX INCHES MINIMUM IN TEN FEET.
- FOUNDATION NOTES:
 - SEE FOUNDATION PLAN FOR NET TOTAL LOAD AND NET SUSTAINED LOAD SOIL BEARING CAPACITY, DEPTH OF FOOTING, AND GEOTECHNICAL ENGINEER REPORT NUMBER AND AUTHOR.
 - ALL FOUNDATION EXCAVATION TO BE CARRIED TO UNDISTURBED MATERIAL OR PLACED IN APPROVED ENGINEERED FILL. EXCAVATIONS SHALL BE FREE OF LOOSE MATERIAL AND WATER.
 - OVER EXCAVATION OF MATERIALS SHALL BE BACK FILLED WITH CONCRETE.
 - ALL BACK FILL AROUND FOOTINGS, BEHIND WALLS, AND UNDER SLABS SHALL BE COMPACTED. SEE SOILS REPORT FOR SITE PREPARATION SPECIFICATIONS.
 - BACK FILLING AGAINST FOUNDATION WALLS WILL NOT BE PERMITTED UNTIL THE FOUNDATION HAS REACHED 28 DAY STRENGTH AND ALL SUPPORTING STRUCTURE IS IN PLACE.
- MATERIALS:
 - PLACE A 6 MIL VAPOR BARRIER OF POLYETHYLENE UNDER ALL SLABS.
 - CONCRETE SHALL BE SUPPLIED AND CONSTRUCTED IN ACCORDANCE WITH ACI-318 LATEST EDITION AND SHALL HAVE A MINIMUM COMPRESSIVE STRENGTH OF 2500 PSI.
 - CONCRETE MUST ATTAIN A MINIMUM COMPRESSIVE STRENGTH OF 2000 PSI AT THE TIME OF STRESSING.
 - PRE STRESSING TENDONS WILL CONSIST OF 270 K 7 WIRE STRAND LOW RELAXATION CABLE WITH PREVENTATIVE LUBRICANT AND WRAPPED WITH PLASTIC SHEATHING CONFORMING TO ASTM A-416. END ANCHORAGE DEVICES WILL CONFORM TO P.T.I. DESIGN SPECIFICATIONS. ALL SHEATHING DAMAGED 4" OR LONGER SHALL BE TAPED SECURELY.
 - 1/2" DIAMETER TENDONS SHALL BE ANCHORED AT 28.9 KIPS PER TENDON, BUT MAY BE INITIALLY STRESSED AT 33.0 KIPS PER TENDON.
 - ELONGATION REPORT MUST BE PROVIDED BY A QUALIFIED ENGINEERING FIRM, OR OTHERS APPROVED BY THIS OFFICE. A REPORT SHALL ALSO BE PROVIDED CERTIFYING THAT THE TENDONS ARE PROPERLY CUT AND GROUTED.
 - MILD STEEL REINFORCING: REBAR-ASTM A-615-60, WELDED WIRE FABRIC-ASTM A-185.
- QUALIFICATION:
 - POST TENSION CONTRACTOR WILL, UPON REQUEST, FURNISH:
 - LABORATORY TESTS ON ANCHORAGE SYSTEM.
 - LATEST CALIBRATION DATE OF EQUIPMENT USED.
 - LABORATORY YES COEFFICIENT OF FRICTION ON TENDONS.
 - MIL TEST ON TENDONS.
- CONSTRUCTION:
 - BEAM DIMENSIONS SHOWN ARE THE MINIMUM SIZE REQUIRED AND MAY NOT BE REDUCED OR ENLARGED WITHOUT PRIOR APPROVAL OF THE STRUCTURAL ENGINEER.
 - EXTERIOR BEAMS ARE TO BEAR 12" (MINIMUM) INTO NATURAL GRADE OR FILL PROPERLY COMPACTED IN COMPLIANCE WITH GEOTECHNICAL ENGINEERS SITE PREPARATION RECOMMENDATIONS.
 - CONCRETE SHALL BE WELL CONSOLIDATED. ESPECIALLY IN THE VICINITY OF TENDON ANCHORAGES.
 - SUPPORT TENDONS AND BARS SECURELY TO PREVENT BOTH VERTICAL AND HORIZONTAL MOVEMENT DURING PLACEMENT OF CONCRETE.
 - THERE WILL BE NO PLUMBING LINES RUNNING PARALLEL TO AND WITHIN OR UNDER ANY FOUNDATION GRADE BEAM.
- SPECIAL NOTES:
 - DETAIL #1 (THIS SHEET) SHALL BE TYPICAL AT ALL EXTERIOR GRADE BEAM DETAILS (UNLESS OTHERWISE NOTED ON DETAIL).
 - DETAIL #10 (THIS SHEET) SHALL BE TYPICAL AT ALL INTERIOR GRADE BEAM DETAILS (UNLESS OTHERWISE NOTED ON DETAIL).
 - BUILDING CONTRACTOR MUST VERIFY ALL FORM SETTING DIMENSIONS, DROPS, OFFSETS, BRICK LEDGES AND BLACKOUTS ON ARCHITECTURAL PLANS AND NOTIFY THE STRUCTURAL ENGINEER OF ANY DISCREPANCIES THAT MAY EXIST ON THESE PLANS PRIOR TO CONSTRUCTION.
 - THE BUILDING CONTRACTOR MUST COORDINATE STRUCTURAL PLANS WITH ARCHITECTURAL AND MECHANICAL PLANS FOR ALL OPENINGS, INSERTS AND OTHER RELATED ITEMS REQUIRED TO COMPLETE THE FOUNDATION.
 - DO NOT SCALE FOUNDATION PLAN OR DETAILS.
- FOUNDATION DESIGN INFORMATION:
 - ALL EXTERIOR GRADE BEAMS ARE 12" WIDE BY 28" DEEP.
 - ALL INTERIOR GRADE BEAMS ARE 12" WIDE BY 24" DEEP.
 - THIS FOUNDATION IS SUITABLE FOR THE SITE AND HAS BEEN DESIGNED IN ACCORDANCE WITH RECOGNIZED ENGINEERING.

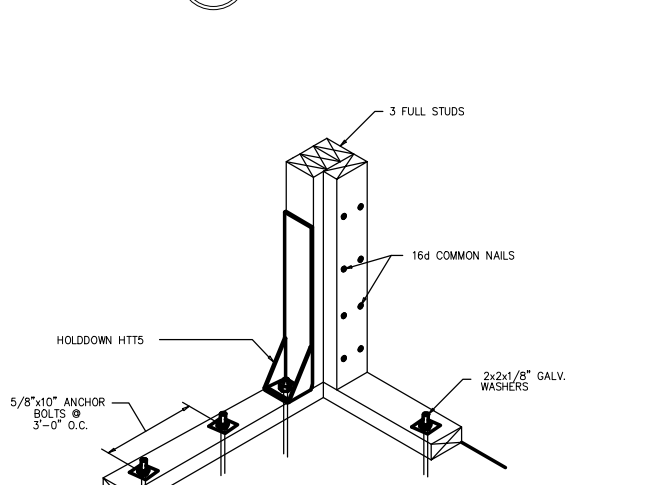
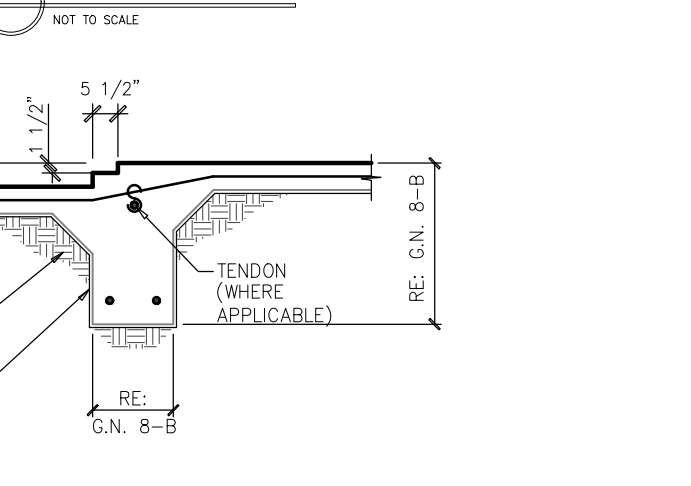
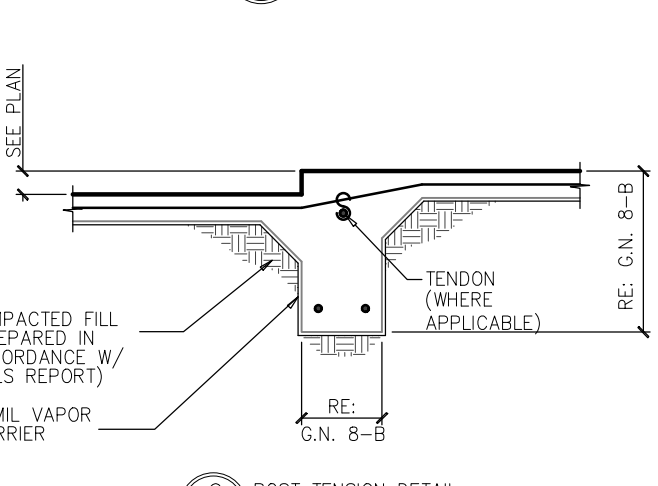
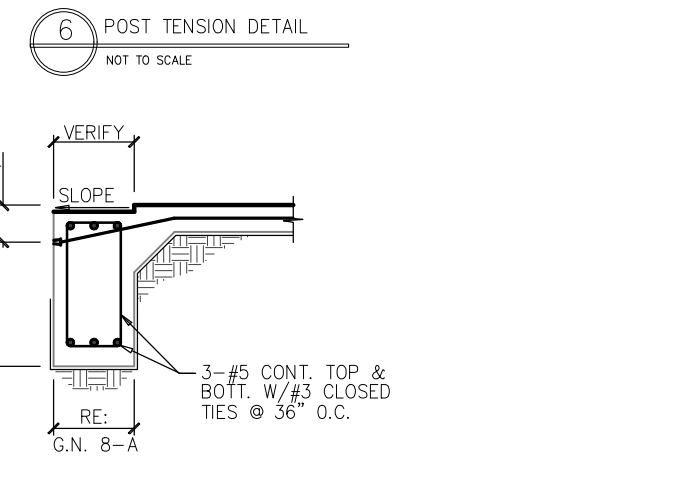
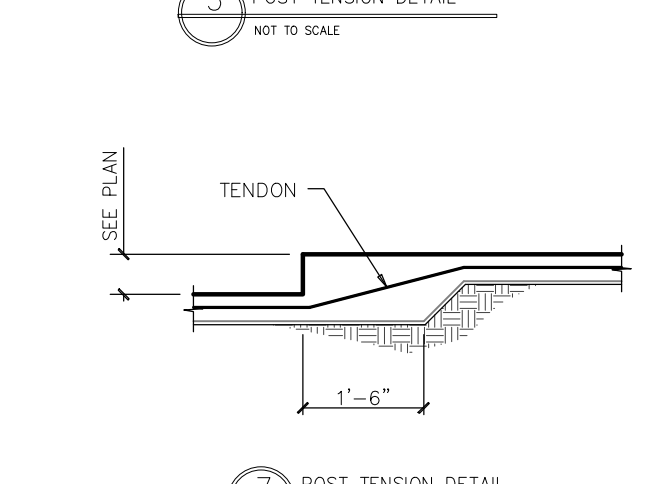
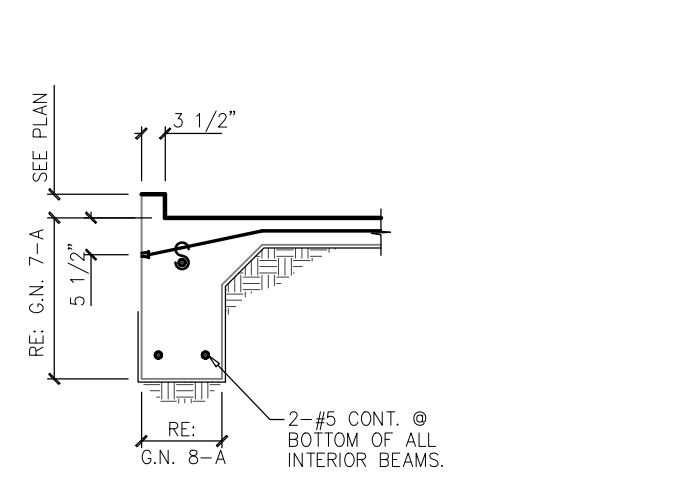
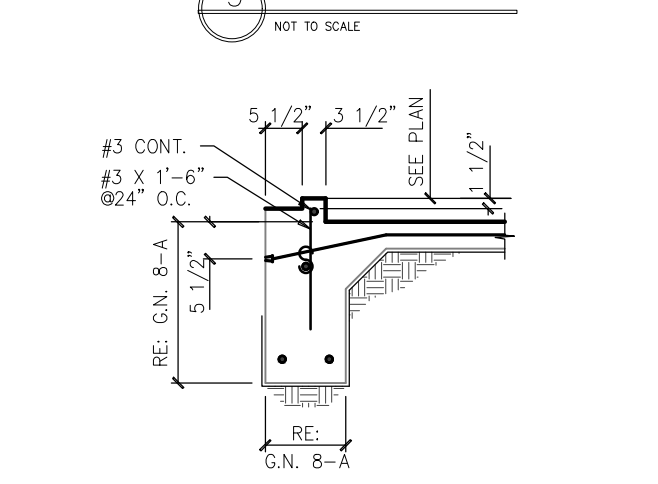
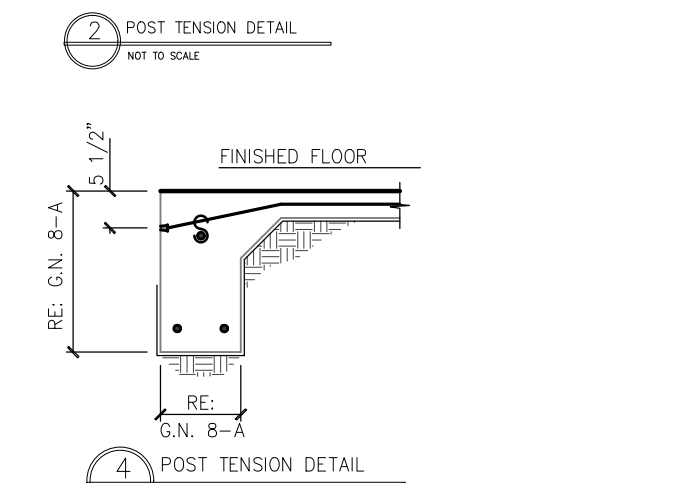
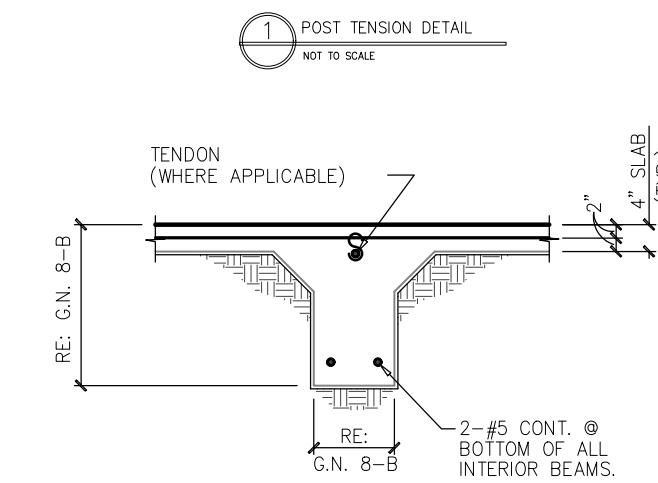
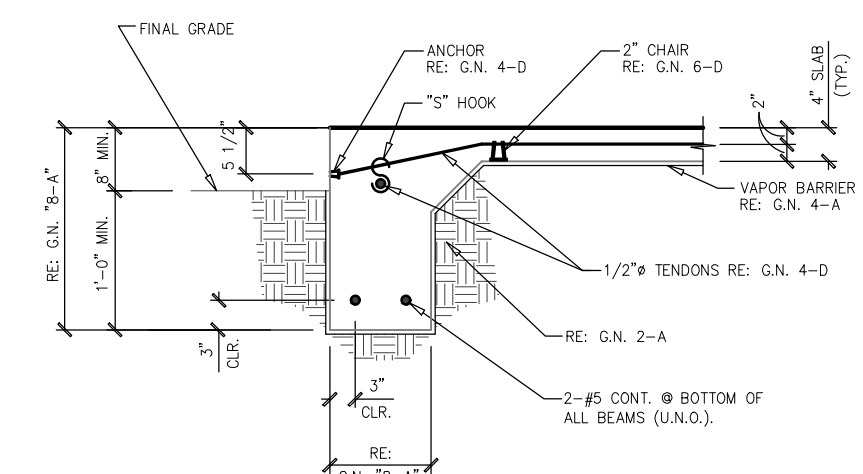
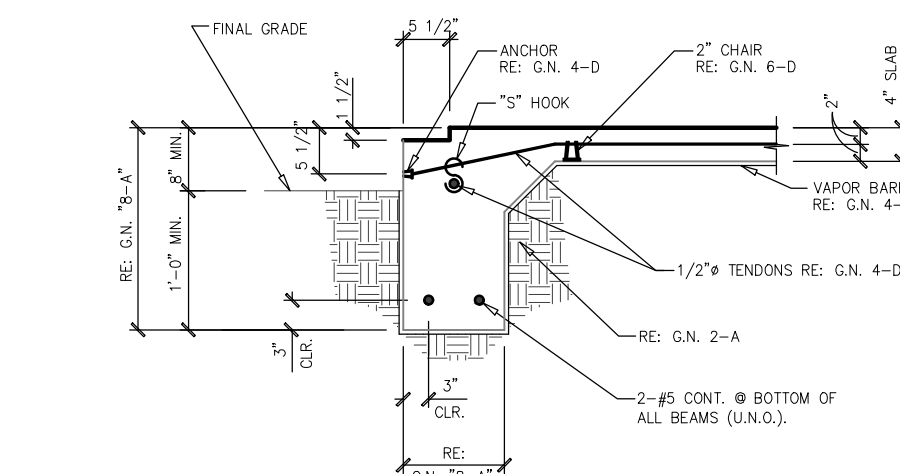
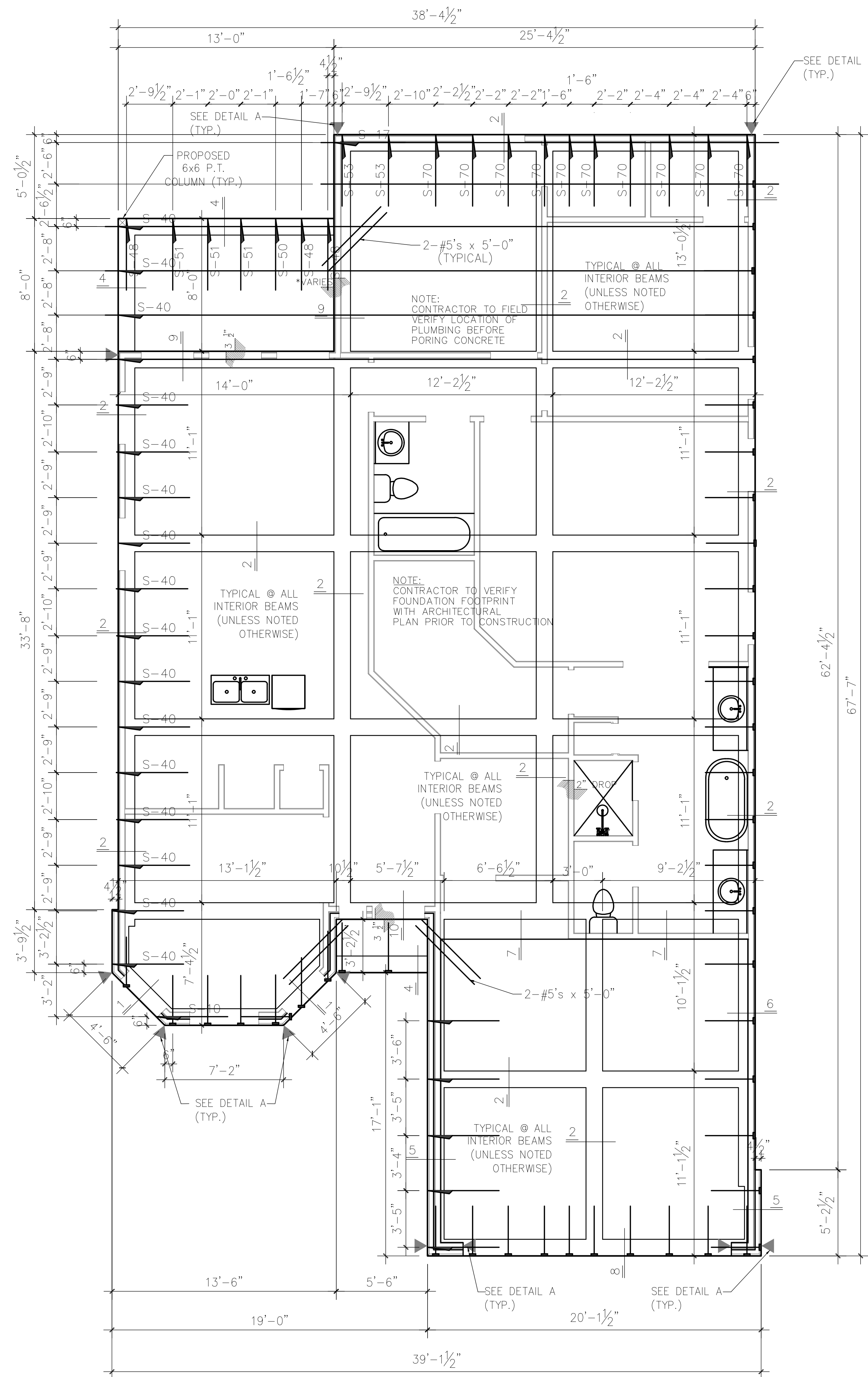

FOUNDATION SOIL PREPARATION OPTION NOTES:

- UNDERCUT UPPER 3 FEET OF EXISTING MODERATE PLASTICITY EXPANSIVE CLAYS AND REPLACE WITH COMPACTED LOW PLASTICITY STRUCTURAL FILL OR TOP THE EXISTING SOILS WITH 3 FEET OF COMPACTED LOW PLASTICITY STRUCTURAL FILL.
- EXCAVATE THE UPPER 3 FEET OF EXISTING MODERATE PLASTICITY EXPANSIVE CLAYS AND THOROUGHLY MIX THE CLAY WITH 6% OF LIME (DRY WEIGHT) UNDER PROPER MOISTURE CONTROL. THEN PLACE THE LIME-STABILIZED CLAYS IN 8-INCH LOOSE LIFTS AND COMPACT EACH LIFT TO AT LEAST 95% OF THE MAXIMUM DRY DENSITY AS SPECIFIED BY ASTM D-698.

1 FOUNDATION PLAN
SCALE: 1/4"=1'-0"

NOTE:

- SOIL BELOW FOUNDATION NEEDS TO BE PREPARED IN ACCORDANCE WITH THE SOIL'S REPORT
- ALLOWABLE SOIL BEARING CAPACITY FOR POST TENSION SLAB ON GRADE: 1,100 PSF
- SOIL REPORT WAS PERFORMED BY COASTAL TESTING LABORATORIES, INC. ON MAY 17, 2021.
- PROJECT NUMBER 2105/1127