



HEDDERMAN SERVICES

281-355-9911

office@hedderman.com

<https://hedderman.com/>



MECHANICAL INSPECTION

902 Rolling Mill Dr
Sugar Land, TX 77498



Inspector

Dylan Hanks

TREC# 25037 EDI# TX-195 TDA#0864394

281-355-9911

office@hedderman.com



PROPERTY INSPECTION REPORT FORM

<i>Name of Client</i>	02/07/2023 9:00 am
902 Rolling Mill Dr, Sugar Land, TX 77498	<i>Date of Inspection</i>
<i>Address of Inspected Property</i>	
Dylan Hanks	TREC# 25037 EDI# TX-195 TDA#0864394
<i>Name of Inspector</i>	<i>TREC License #</i>
<i>Name of Sponsor (if applicable)</i>	<i>TREC License #</i>

PURPOSE OF INSPECTION

A real estate inspection is a visual survey of a structure and a basic performance evaluation of the systems and components of a building. It provides information regarding the general condition of a residence at the time the inspection was conducted. *It is important* that you carefully read ALL of this information. Ask the inspector to clarify any items or comments that are unclear.

RESPONSIBILITY OF THE INSPECTOR

This inspection is governed by the Texas Real Estate Commission (TREC) Standards of Practice (SOPs), which dictates the minimum requirements for a real estate inspection.

The inspector IS required to:

- use this Property Inspection Report form for the inspection;
- inspect only those components and conditions that are present, visible, and accessible at the time of the inspection;
- indicate whether each item was inspected, not inspected, or not present;
- indicate an item as Deficient (D) if a condition exists that adversely and materially affects the performance of a system or component **OR** constitutes a hazard to life, limb or property as specified by the SOPs; and
- explain the inspector’s findings in the corresponding section in the body of the report form.

The inspector IS NOT required to:

- identify all potential hazards;
- turn on decommissioned equipment, systems, utilities, or apply an open flame or light a pilot to operate any appliance;
- climb over obstacles, move furnishings or stored items;
- prioritize or emphasize the importance of one deficiency over another;
- provide follow-up services to verify that proper repairs have been made; or
- inspect system or component listed under the optional section of the SOPs (22 TAC 535.233).

RESPONSIBILITY OF THE CLIENT

While items identified as Deficient (D) in an inspection report DO NOT obligate any party to make repairs or take other actions, in the event that any further evaluations are needed, it is the responsibility of the client to obtain further evaluations and/or cost estimates from qualified service professionals regarding any items reported as Deficient (D). It is recommended that any further evaluations and/or cost estimates take place prior to the expiration of any contractual time limitations, such as option periods.

Please Note: Evaluations performed by service professionals in response to items reported as Deficient (D) on the report may lead to the discovery of additional deficiencies that were not present, visible, or accessible at the time of the inspection. Any repairs made after the date of the inspection may render information contained in this report obsolete or invalid.

REPORT LIMITATIONS

This report is provided for the benefit of the named client and is based on observations made by the named inspector on the date the inspection was performed (indicated above).

ONLY those items specifically noted as being inspected on the report were inspected.

This inspection IS NOT:

- a technically exhaustive inspection of the structure, its systems, or its components and may not reveal all deficiencies;
- an inspection to verify compliance with any building codes;
- an inspection to verify compliance with manufacturer’s installation instructions for any system or component and DOES NOT imply insurability or warrantability of the structure or its components.

NOTICE CONCERNING HAZARDOUS CONDITIONS, DEFICIENCIES, AND CONTRACTUAL AGREEMENTS

Conditions may be present in your home that did not violate building codes or common practices in effect when the home was constructed but are considered hazardous by today's standards. Such conditions that were part of the home prior to the adoption of any current codes prohibiting them may not be required to be updated to meet current code requirements. However, if it can be reasonably determined that they are present at the time of the inspection, the potential for injury or property loss from these conditions is significant enough to require inspectors to report them as Deficient (D). Examples of such hazardous conditions include:

- malfunctioning, improperly installed, or missing ground fault circuit protection (GFCI) devices and arc-fault (AFCI) devices;
- ordinary glass in locations where modern construction techniques call for safety glass;
- malfunctioning or lack of fire safety features such as smoke alarms, fire-rated doors in certain locations, and functional emergency escape and rescue openings in bedrooms;
- malfunctioning carbon monoxide alarms;
- excessive spacing between balusters on stairways and porches;
- improperly installed appliances;
- improperly installed or defective safety devices;
- lack of electrical bonding and grounding; and
- lack of bonding on gas piping, including corrugated stainless steel tubing (CSST).

Please Note: items identified as Deficient (D) in an inspection report DO NOT obligate any party to make repairs or take other actions. The decision to correct a hazard or any deficiency identified in an inspection report is left up to the parties to the contract for the sale or purchase of the home.

This property inspection report may include an inspection agreement (contract), addenda, and other information related to property conditions.

INFORMATION INCLUDED UNDER "ADDITIONAL INFORMATION PROVIDED BY INSPECTOR", OR PROVIDED AS AN ATTACHMENT WITH THE STANDARD FORM, IS NOT REQUIRED BY THE COMMISSION AND MAY CONTAIN CONTRACTUAL TERMS BETWEEN THE INSPECTOR AND YOU, AS THE CLIENT. THE COMMISSION DOES NOT REGULATE CONTRACTUAL TERMS BETWEEN PARTIES. IF YOU DO NOT UNDERSTAND THE EFFECT OF ANY CONTRACTUAL TERM CONTAINED IN THIS SECTION OR ANY ATTACHMENTS, CONSULT AN ATTORNEY.

ADDITIONAL INFORMATION PROVIDED BY INSPECTOR

Hedderman Engineering Inc.:

>It is the purpose of this report to give our client my educated and experienced opinion of the condition and function of the stated property as visually inspected by Hedderman Engineering, Inc. The inspection performed on this property is of a general nature and includes the following systems: electrical, mechanical, and plumbing. This does not include any specialized inspections and/or inspections of any hazardous materials (such as done in environmental inspections) or any of the following: structural systems, mold, audio/visual components, lighting control systems, hazardous materials and gases, rated walls, lead paint, destructive insects or pest, security items, water or air treatment systems, etc. This inspection is limited to those components which were visible and readily accessible at the time of the inspection, without disassembling or removal of any portion of the structure, mechanical equipment, plumbing equipment, or electrical wiring and equipment is beyond the scope of this inspection. It is noted that this report contains the opinions of this inspector of the stated property as it appeared on the day of the inspection and is in no way a warranty of any component in the days and future following the inspection. All mechanical components are judged on the basis of age, condition, and the function of those items as they appeared on the day of the inspection and are not guaranteed to continue functioning in that manner in the future. It is recommended that the our client purchase a home warranty policy to protect oneself from both unexpected and anticipated problems that may occur in the future.

>It is noted that Hedderman Engineering Inc. is not responsible for any problems found in the house during or after components are opened up, disassembled, uncovered, made visible, or made accessible by another entity after the inspection is completed.

>If a builder or service contractor examines an area of question and comes to the conclusion that there is no repair needed, have them present to you in writing that the item is in compliance with a prevailing code and is functioning properly, and not in need of repair.

>It is the intent of this inspector to work in compliance with the Standards Of Practice For Real Estate Inspectors. It is not required of this company to exceed these standards. You may obtain a copy of the document referred to above by contacting the Texas Real Estate Commission. It is also noted that this inspection is not a "code inspection", but rather an inspection of the condition and function of the stated property.

>Although this report may include observations of some building code violations, total compliance with mechanical, plumbing, electrical codes, specifications, and/or legal requirements are specifically excluded. We do not perform "code" inspections, and since building codes change every few years, our inspections are not performed with the intention of bringing every item in the

property into compliance with current code requirements. Rather, the standard of our inspections is a **performance standard** to determine if the items inspected are functioning at the time of the inspection, or are in need of repair. This is particularly applicable to Home Warranty policies, where the standards of the Home Warranty service company are often different than our stated performance standard for judging whether a piece of equipment is functional or in need of repair. If you intend to rely on a Home Warranty policy, then it is recommended that you contact the appropriate service companies for a more in-depth analysis of what may be required to meet their standards should a claim be made against the policy.

>If there are any questions or concerns please contact Hedderman Engineering, Inc. at 281-355-9911 or Office@HeddermanEngineering.com.

I. STRUCTURAL SYSTEMS

- A. Foundation**
Comments:
- B. Grading and Drainage**
Comments:
- C. Roof Covering Materials**
Comments:
- D. Roof Structures & Attics**
Comments:
- E. Walls (Interior and Exterior)**
Comments:
- F. Ceilings and Floors**
Comments:
- G. Doors (Interior and Exterior)**
Comments:
- H. Windows**
Comments:
- I. Stairways (Interior and Exterior)**
Comments:
- J. Fireplaces and Chimneys**
Comments:
- K. Porches, Balconies, Decks and Carports**
Comments:

The structural portions of this property were inspected by an engineer from Hedderman Engineering Inc. per the inspection agreement between this firm and our client. All comments regarding the structure and property grade are found in the structure report that is created and provided by the engineers at Hedderman Engineering Inc.

According to HAR, the house was built in 1981.

Orientation - House Facing North:

For the purpose of the inspection, North is considered to be the front of the house.

I=Inspected

NI=Not Inspected

NP=Not Present

D=Deficient

I NI NP D

II. ELECTRICAL SYSTEMS

A. Service Entrance and Panels

Comments:

Electrical System Description:

The electrical service is provided by a 120/240 volt, single-phase, 125-ampere service to an electric meter located at the west side of the house.

Electrical Wiring Information

<u>Service Wires</u>	<u>Branch Circuit Wires</u>	<u>Grounded or Ungrounded System</u>
Appears to be 1/0 Aluminum	Copper	Grounded

Breaker Panel Information

<u>Location</u>	<u>Manufacturer</u>	<u>Rating - Amps</u>
West	Square D	Not visible

Circuit Breaker Wiring Diagram

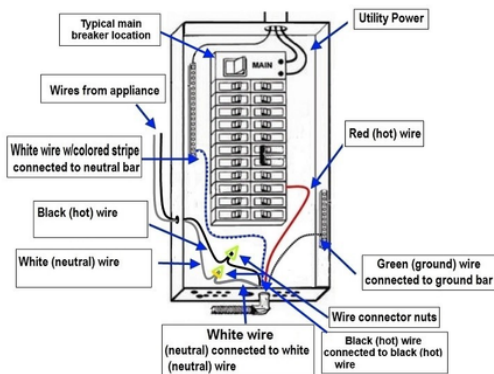

Breakers - Routine Check:

I=Inspected

NI=Not Inspected

NP=Not Present

D=Deficient

I NI NP D

It is a general recommendation that all circuit breakers be tripped off and on at least once a year to ensure that they are still physically able to trip off. Occasionally, the points on a breaker will fuse to the main bus in the panel, preventing the breaker from tripping off, even if there is an overload on the circuit. If this condition occurs, it can be a fire hazard.

AFCI Breakers Not Present - Home built pre-AFCI:

The breaker panel(s) did not contain any Arc Fault Circuit Interrupters (AFCI). This is an “as-built” condition, that does not meet current building code standards. AFCI devices are intended to protect against fires caused by electrical arcing in the wiring, by shutting off the power to the circuit when an electrical arc is detected in the circuit. Homes built prior to 2002 were not required by the National Electrical Code (NEC) to be protected by AFCI devices. Since this home was built prior to 2002, the breaker panel is not required to be retrofitted with new AFCI breakers. If adding AFCI breakers is desired, it is recommended that you contact an electrician for further information.

Breaker panel legend:

The circuit breakers were labeled to identify the circuits they were protecting. We did not trip off every breaker and trace out every circuit and, therefore, could not verify the accuracy of the labeling. If further investigation is desired, it is recommended that an electrician be contacted.

1: Manufacturer's data sticker

The manufacturer's data sticker was missing or illegible and we could not determine the rating of the breaker panel. It is recommended that an electrician be contacted to evaluate determine if the panel is adequately rated for this application.

Further investigation is recommended

Recommendation: Contact a qualified professional.



2: No Antioxidation Solution

The aluminum conductors were not coated with an anti-oxidation solution. Per the standards set forth by the Texas Real Estate Commission, we are required to recommend that the wires should be coated with an anti-oxidation solution, however this is not required by the current building codes.

Obtain cost estimate



I=Inspected

NI=Not Inspected

NP=Not Present

D=Deficient

I NI NP D

3: Cover Plate - Missing screw

The dead front cover for the breaker panel was missing one or more screws.

Obtain Cost Estimate



4: Ground Rod - Not flush with grading

The ground rod was sticking out of the ground a few inches, and, since ground rods are typically 8 feet long and all 8 feet of the rod are required to be in the ground, it is recommended that the ground rod be pounded down flush with the top of the ground. The clamp on the rod should be an acorn clamp approved for direct burial in the ground.

Obtain Cost Estimate

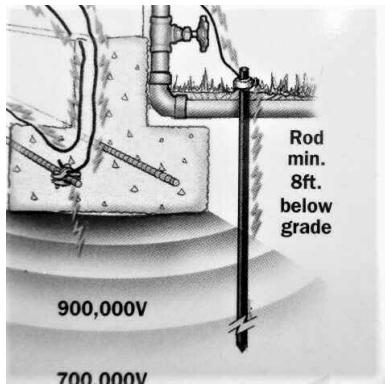

B. Branch Circuits, Connected Devices, and Fixtures

Type of Wiring: Copper -

Comments:

GFCI Outlet - Functional : Kitchen sink area, All bathrooms -
Outlets that were protected by ground fault circuit interrupt (GFCI) devices were present and functioning properly at the time of the inspection. The GFCI devices were checked and the power to the outlets turned off when the test buttons were pressed. It is pointed out that GFCI devices can stop tripping and/or resetting properly at any point. The devices should be tested periodically and replaced when necessary.

Outlets - Some inaccessible:
Some of the receptacle outlets in the home were inaccessible and could not be reached for inspection due to furniture, heavy storage items, personal effects, or conditions outside the control of the inspector.

Low Voltage Systems - Not inspected:
It is pointed out that low voltage systems, low voltage wiring, and low voltage connections were not included in the scope of the inspection and were not checked, including: audio/visual systems, alarm systems, data

I=Inspected

NI=Not Inspected

NP=Not Present

D=Deficient

I NI NP D

lines, and phone lines. If further investigation is desired, it is recommended that a service company be contacted.

Smoke and Carbon Monoxide Detectors:

We could not determine if the smoke and/or carbon monoxide detectors are connected to the security alarm system as is common practice, therefore, to avoid triggering the security alarm we did not operationally check each device. Further investigation is recommended with a service company who specializes in this field to determine if the devices are interconnected as currently required and functioning properly. For safety purposes, it is recommended that smoke detectors and carbon monoxide detectors be replaced every ten years. Further investigation is recommended.

1: GFCI - Missing at outlet

Garage door opener, Kitchen counter tops -

A GFCI device was not installed at one or more locations that are currently required to have GFCI protection. It is recommended that an electrician install GFCI devices at all of the currently required locations.

Obtain Cost Estimate

Recommendation: Contact a qualified professional.



2: GFCI Missing - Outlet within 6 feet of sink/tub

Kitchen

An outlet that was with in six feet of the rim of a sink or tub was no protected by a GFCI device. The outlet should be protected as currently required.

Obtain Cost Estimate

Recommendation: Contact a qualified professional.



3: Outlet - Damaged

Garage

An outlet was damaged and should be replaced.

Obtain Cost Estimate

Recommendation: Contact a qualified professional.

I=Inspected

NI=Not Inspected

NP=Not Present

D=Deficient

I NI NP D



4: Cover Plate - Damaged/Missing

Kitchen, Entry, Master Bathroom

A missing or damaged cover plate was observed.

Obtain Cost Estimate

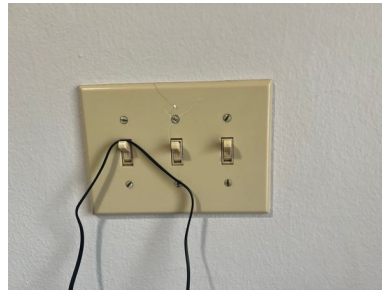

5: Outlet - Ungrounded

Kitchen, North Bedroom

A three prong outlet that was not grounded properly and needs to be repaired. It is recommended that an electrician be contacted, and the necessary repairs made to the outlet.

Obtain Cost Estimate



I=Inspected

NI=Not Inspected

NP=Not Present

D=Deficient

I NI NP D

6: Outlets - Box extenders missing at backsplash

We observed outlets located in countertop backsplashes that were not protected by extender boxes. This is considered to be a fire hazard, and it is recommended that the extender boxes be installed.

Obtain Cost Estimate

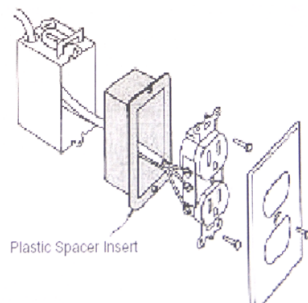

7: Exterior Outlet - No water tight cover

South

An exterior outlet that was not protected by a water tight cover plate was observed.

Obtain cost estimate



HEI File Photo

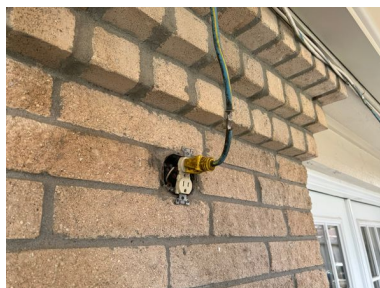

8: Cover Plate - Missing screw

Wet Bar, Hall Bath

A screw was missing on cover plate.

Obtain Cost Estimate



9: Light Fixture - Nonfunctional

A light fixture that was non-functional when the switch was on was observed. The problem may be a burned out bulb, defective light fixture, or defective switch.

I=Inspected

NI=Not Inspected

NP=Not Present

D=Deficient

I	NI	NP	D
---	----	----	---

Further investigation is recommended



10: Light Fixture - Closet missing cover

One or more of the closet light fixtures are missing covers. For safety purposes, it is recommended that protective covers be installed over the bare bulbs.

Obtain Cost Estimate



11: Light Fixture - Missing

South

A light fixture was missing.

Obtain Cost Estimate



12: Light Fixture - Damaged

West

A light fixture that was damaged and needs to be replaced was observed.

Obtain cost estimate

Recommendation: Contact a qualified professional.

I=Inspected

NI=Not Inspected

NP=Not Present

D=Deficient

I NI NP D



13: Open junction box

Attic

An open junction box that was missing a cover was observed.

Obtain Cost Estimate

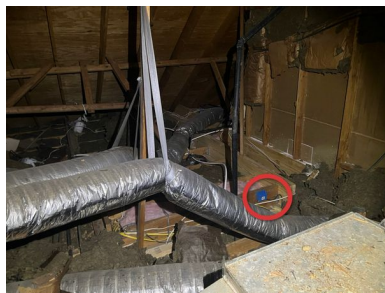

14: Smoke detectors - Current standards not met

The house does not meet the current code concerning smoke alarms. This house is an older home and, if bringing the house into current standards is desired, it is recommended that you contact a service contractor to make all of the needed repairs. Smoke detectors are currently required to be connected in a manner that causes one detector to engage each other detector should an alarm be tripped, They are also required to be hardwired into the electrical system and contain a battery back up. Lastly, smoke detectors are required inside each bedroom, outside of bedroom areas, hallways, stairwells, and at each level of the structure.

Obtain Cost Estimate

Recommendation: Contact a qualified professional.

15: Carbon Monoxide Detectors - Current standards not met

Carbon monoxide detectors were not installed at all of the currently required locations and it is recommended that approved carbon monoxide detectors be installed. Currently, carbon monoxide detectors are required outside each sleeping area.

Obtain Cost Estimate

Recommendation: Contact a qualified professional.

I=Inspected NI=Not Inspected NP=Not Present D=Deficient

I NI NP D

III. HEATING, VENTILATION AND AIR CONDITIONING SYSTEMS

A. Heating Equipment

Comments:

Type of System: Forced Air

Energy Sources: Natural Gas

It is pointed out that our inspection of the air conditioning and heating system(s) is a limited, visual inspection in accordance with the TREC SOP, where we check the equipment as it has been installed to determine whether or not the system(s) is cooling and/or heating at the time of the inspection. Our inspection is a cursory inspection of the apparent function, as we do not determine the sizing, adequacy, or design of any component in the system, or the compatibility of the individual components, nor the installation of the system(s) to be in conformity to the latest building code requirements. If you desire an in-depth analysis of the HVAC system(s) by a qualified service technician using specialized diagnostic equipment, then it is recommended that a service company be contacted to analyze the system(s). This is particularly important if the system(s) is an older system and has only a limited amount of remaining life due to its age and/or condition.

Gas Furnace Description:

The heating for the property was provided the following natural gas-fired equipment:

<u>ZONE</u>	<u>BRAND</u>	<u>BTU</u>	<u>DATE</u>	<u>LOCATION</u>
House	Lennox	120K	Not visible	Attic

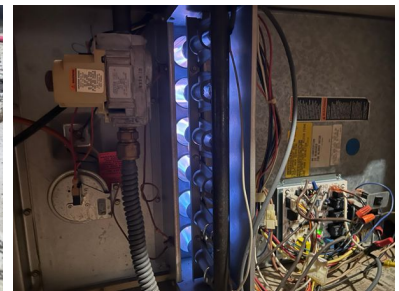
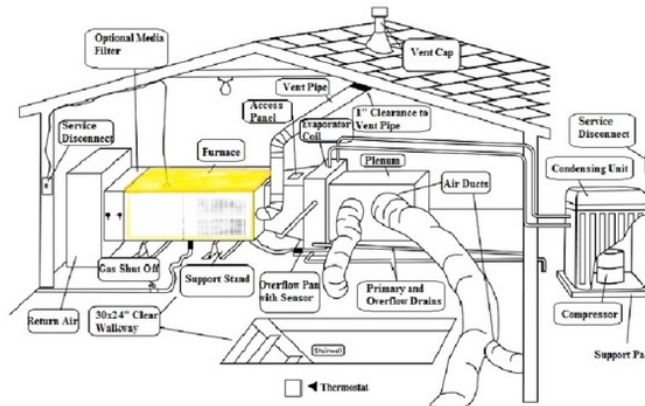

I=Inspected

NI=Not Inspected

NP=Not Present

D=Deficient

I NI NP D

Heating Equipment - Functional:

The heating equipment was observed to be operating and functional at the time of the inspection. The heating equipment responded to the thermostat(s) and the equipment appeared to be heating the air adequately.

Heat Exchanger - Information:

Gas furnaces are constructed in such a way that the units must be dismantled in order to view the entire heat exchanger inside. The equipment was not dismantled, and the heat exchanger was not able to be viewed for evidences of cracks. If further investigation is desired, it is recommended that a service company be contacted to dismantle the equipment. It is pointed out, for safety purposes, the heat exchanger should be inspected by an HVAC service company once a year.

1: End of Life

Due to the age and condition of the equipment, it is our opinion that the unit is essentially at the end of its serviceable life and should be replaced at this time.

Obtain Cost Estimate

2: Furnace - Cycling On and Off

The burner for the furnace was cycling on and off indicating a problem with the equipment. Have a service company find the source of the problem and make any necessary repairs.

Obtain Cost Estimate

3: Flexible gas line inside casing

The flexible gas line extended up inside the furnace casing to connect to the gas valve. The gas piping located inside the furnace casing should be solid steel, and the steel piping should extend outside the furnace casing. The connection between the flexible gas line and the steel gas line should then be made outside of the furnace casing.

Obtain Cost Estimate

Recommendation: Contact a qualified professional.

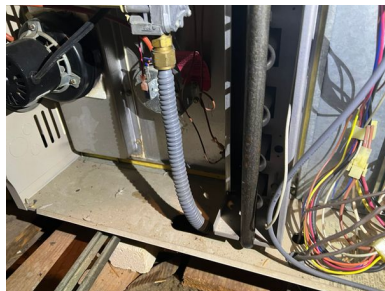

4: Sediment trap missing

Sediment traps were not installed at the gas supply lines for one or more of the gas fired furnaces. A sediment trap is intended to catch sediment/moisture/debris in a gas supply line before it can enter into the gas equipment.

Obtain Cost Estimate

Recommendation: Contact a qualified professional.

B. Cooling Equipment

Comments:

I=Inspected

NI=Not Inspected

NP=Not Present

D=Deficient

I NI NP D

Type of System: Split system

The inspection of the HVAC system is cursory in nature in accordance with the TREC SOP. We measure the temperature drop (ΔT) across the indoor coil(s) at the time of the inspection and our observations have been recorded in this report. It is pointed out that our measurements of the cooling performance of the equipment is only at a "point in time", and cannot reflect whether the equipment has been recently serviced, or what the future performance of the equipment will be after the day of the inspection. Further investigation with the homeowner is recommended to determine when the equipment was last serviced. It is pointed out that an HVAC license is required to check the refrigerant pressures for the A/C equipment, therefore the refrigerant pressure was not checked during the inspection.

A/C Equipment Description:

The type of air conditioning for the property is a forced air split system. The cooling equipment for the property was as follows:

Zone	Brand	Size/Age Condenser	Size/Age Coil	Temp Drop Degrees
House	Carrier	5-ton 1999	5-ton 1999	14

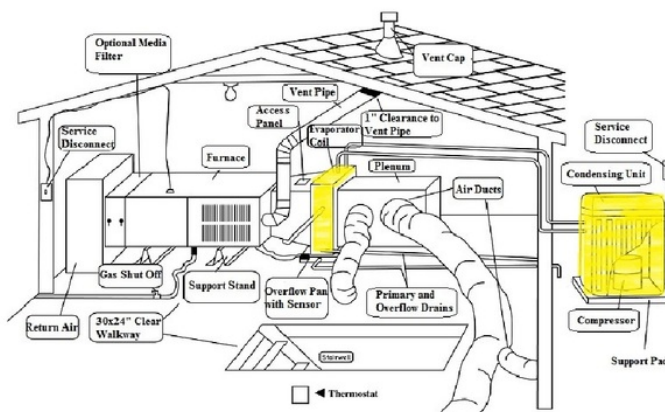

I=Inspected

NI=Not Inspected

NP=Not Present

D=Deficient

I NI NP D



Condensing Unit Equipment - Functional:

The condensing unit equipment was functional at the time of the inspection. The equipment responded to the corresponding thermostat, and the compressor components and fan motor components appeared to be operating as evidenced by the cooling performance of the system.

Coil Equipment - Functional:

The coil equipment was operating and was providing a degree of cooling at the time of the inspection.

Window Unit - Cooling properly:

No items requiring repair were visible at the time of the inspection for the cooling performance of the unit. The unit was observed to be cooling 16-20 degrees, which is adequate.



Cooling Performance:

We measure the temperature drop (ΔT) across the indoor coil(s) at the time of the inspection and our observations have been recorded in this report. It is pointed out that our measurements of the cooling performance of the equipment is only at a “point in time”, and cannot reflect whether the equipment has been recently serviced, or what the future performance of the equipment will be after the day of the inspection. Further investigation with the homeowner is recommended to determine when the equipment was last serviced.

1: Low temperature drop

The system had a less than normal temperature differential across the evaporator coils (less than 16 degrees). Have a service company find the source of the problem and provide a cost estimate to make any necessary repairs.

Obtain Cost Estimate

2: R22 Refrigerant

The condensing unit label indicate that the equipment operates with the old R-22 refrigerant, rather than the currently required R410A refrigerant. R-22 is no longer the current standard in the industry and will be more expensive to refill when servicing. It is recommended that a service company be contacted for further investigation.

Further investigation is recommended

I=Inspected

NI=Not Inspected

NP=Not Present

D=Deficient

I NI NP D

3: Overflow Pan - Water sensor not present

The overflow pan under the coil was not equipped with a water sensor nor was a sensor installed in the primary drain line. The sensor is intended to turn off the air conditioning system should the pan fill with water. It is recommended that you consider having an overflow pan water sensor installed.

Obtain cost estimate

4: Primary Drain Lines - Terminated in plumbing vent

The primary condensate drain line for the unit terminated into a plumbing vent pipe in the attic. This can allow sewer gases to backup into the living space, which is a hazard. It is recommended that the primary drain line be rerouted and terminated in an approved manner.

Obtain Cost Estimate



C. Duct Systems, Chases, and Vents

Type of ducts: Flex ducts -
Comments:

1: Ducts - No clearance between ducts

We observed that some of the air ducts in the attic were in contact with each other, which can cause condensation to form on the outside of the ductwork. It is recommended that the ducts that are touching be separated. Typically, this is done by inserting a piece of fiberglass batt insulation or duct board between the ducts.

Obtain Cost Estimate

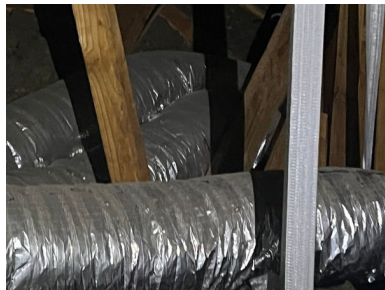

2: Ducts - Not supported properly

The ducts were laying on the insulation and ceiling joints and are not supported properly. The ducts should be supported in accordance with the manufacturer's installation instructions, which typically includes hanging the ducts from the rafters supported by 1 1/2 inch straps spaced approximately every four feet. Have a service company make the necessary repairs.

Obtain Cost Estimate

I=Inspected

NI=Not Inspected

NP=Not Present

D=Deficient

I	NI	NP	D
---	----	----	---



I=Inspected

NI=Not Inspected

NP=Not Present

D=Deficient

I NI NP D

IV. PLUMBING SYSTEMS

A. Plumbing Supply, Distribution Systems, and Fixtures

Comments:

Location of water meter: The street curb

Location of main water supply valve: East

Static water pressure reading: 52 PSI

Water Supply Material: PEX

A plumbing system typically consists of three major components, including the potable water supply piping; the waste or drain piping; and the plumbing fixtures. The distribution piping brings the water from the public water main or a private well to the individual fixtures throughout the property. The water distribution system is under pressure, usually from 40 psi to 70 psi. The waste or drain piping carries the waste water and products underground to the sewer system or septic tank, and the waste piping is not under pressure, but operates by gravity flow. We typically run water down the drains from the sinks, tubs, showers, and toilets, but this cannot simulate the waste flow characteristics of full occupancy. There may be partial blockage of the underground waste lines from debris, broken pipes, or tree roots that cannot be detected by a visual inspection. If you desire a more in-depth inspection, it is recommended that you contact a qualified plumber.

Main Water Shut Off Valve Location: East side -

The main shut-off valve for the water line service piping is intended to provide a means to disconnect the water service to the structure/property.



Static Water Pressure: 50-55 PSI -

The static water pressure at the property was measured with a water pressure gauge at the hose bibb nearest to the shut off valve at the time of the inspection.



Cold water only:

The wet bar sink was supplied by cold water only.

I=Inspected

NI=Not Inspected

NP=Not Present

D=Deficient

I	NI	NP	D
---	----	----	---



1: Vacuum Breaker - Missing

The atmospheric vacuum breaker devices were missing at one or more of the hose bibbs, and it is recommended that they be installed to prevent cross connections, which can allow contaminated water to enter the potable water supply.

Obtain Cost Estimate



2: Hose Bibb - Leaking at valve stem

A leak was observed at a hose bibb around the valve stem.

Obtain Cost Estimate



3: Shower/Tub - Caulk valves

Master Bathroom

The tub and/or shower valves and/or faucet needs to be caulked to prevent water from entering the wall cavity behind the valves/faucet.

Obtain Cost Estimate

I=Inspected

NI=Not Inspected

NP=Not Present

D=Deficient

I NI NP D

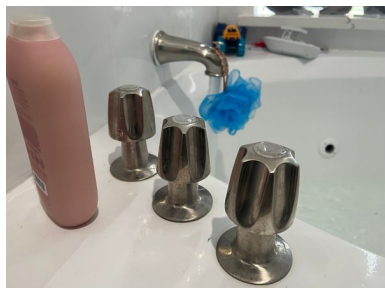

B. Drains, Wastes, and Vents

Sewer Piping Material: Appears to be Cast iron ABS and PVC -
Comments:

Sewer System - Functional:

No evidences of a system wide problem were observed when the system was operationally checked by running water through each of the plumbing fixtures during the duration of the inspection. It is noted that most of the drain waste system in the walls, under the floors, and in the ceilings is not visible. If further investigation is desired, it is recommended that a plumber be contacted to perform an in depth survey with a camera or hydrostatic test.

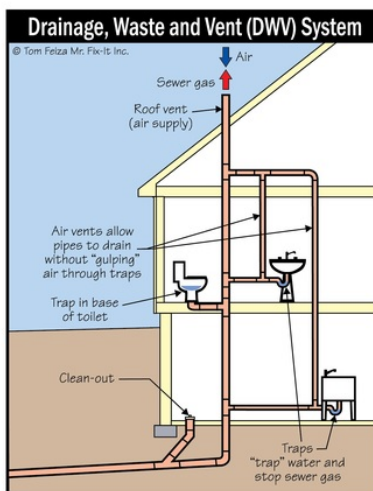

Sewer Clean Out Present: West side -

A sewer clean out was present. The clean out is needed in the event of a stoppage in the main sewer drain line, and the clean out is where a sewer snake would be utilized to remove a clog in the sewer line.



I=Inspected NI=Not Inspected NP=Not Present D=Deficient

I NI NP D

C. Water Heating Equipment
Energy Source: Natural gas -
Capacity: 40 Gallons

Gas Water Heater Description:

The hot water for the property was provided by the following natural gas fired gas water heater(s):

Location	Brand	Capacity	Age	Energy Type
Utility Room	Bradford White	40 Gallon	2017	Gas

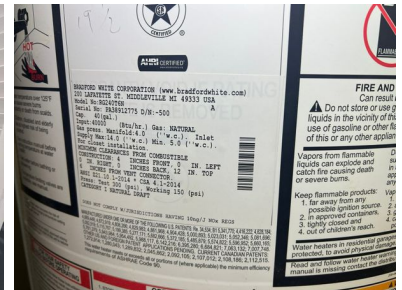
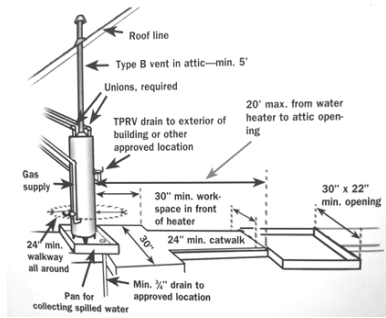

Water Heater Equipment - Functional:

The water heater equipment was functional at the time of the inspection and providing hot water to the applicable plumbing fixtures.

Hot water - Temperature:

The generally recommended maximum temperature setting for a hot water heater, to prevent accidental scalding, is 120-125 degrees. It is recommended that the water heater thermostat be adjusted to and maintained in this temperature range.

WATER TEMPERATURE	Time required for a third-degree burn to occur	
	Adults (skin thickness of 2.5 mm)	Children (skin thickness of .68 mm)
155°F 68°C	1 second	0.5 second
149°F 65°C	2 seconds	1 second
143°F 62°C	5 seconds	1 second
137°F 58°C	15 seconds	4 seconds
131°F 54°C	1 minute	10 seconds
125°F 51°C	2 minutes	1.5 minutes
120°F 48°C	5 minutes	2.5 minutes
107°F 42°C	Safe temperature for bathing	

For SI: °C = (°F) - 32 / 1.8 or (°F) = (°C) × 1.8 + 32
 Figure P278.3
 TEMPERATURE BURN CHART



Temp/Pressure Relief Valve - Information:

I=Inspected

NI=Not Inspected

NP=Not Present

D=Deficient

I NI NP D

Temperature/pressure relief valves are not operationally checked by this firm during the inspection. Valves typically do not reseal properly when they are operated, which causes the valves to leak. It is best to replace the temperature/pressure relief valves for water heaters every 2-3 years to prevent them from getting clogged with mineral deposits.

1: Tank - Gurgling noise

The tank was observed to be gurgling while it was heating, indicating a buildup of scale and other deposits inside the water heater. It can be anticipated that the condition will continue to worsen until the water heater is replaced. It is recommended that a plumber be contacted for further investigation and a cost estimate for any needed repairs.

Obtain Cost Estimate

D. Hydro-Massage Therapy Equipment

Comments:

Whirlpool tub - Functional: Pump operational, Aerators functional -

The whirlpool tub was operated and appeared to be functioning properly at the time of the inspection.

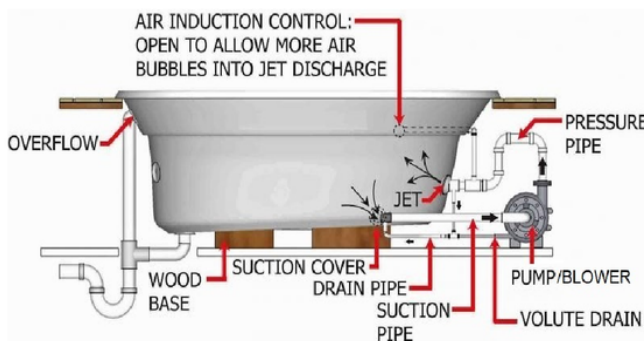

No access to pump/blower:

Access to the pump/blower was not provided at the time of the inspection, therefore the pump/blower, wiring, and plumbing under the tub were not visually checked. If further investigation is desired, it is recommended that access to the underside of the tub be made. It is pointed out, if repairs become necessary, an access opening will need to be installed.

Tub trap access tiled over:

The trap area of the whirlpool tub was not accessible and was not viewed. Tile was installed around the tub, and no access has been provided to the pump and plumbing under the tub.

1: Hardware in need of repair

Jet face missing -

I=Inspected

NI=Not Inspected

NP=Not Present

D=Deficient

I NI NP D

The hardware was in need of repair.

Obtain cost estimate

Recommendation: Contact a qualified professional.



2: No GFCI protection

The whirlpool tub was not protected by a Ground Fault Circuit Interrupt device.

Obtain Cost Estimate

E. Gas Distribution Systems and Gas Appliances

Location of Gas Meter: South side -

Type of gas distribution piping material: Steel piping with flexible appliance connectors

Comments:

A cursory visual inspection was performed on the gas supply piping. The inspection was limited to the gas pipes that were visible and accessible at the time of the inspection, without digging to uncover gas lines. The underground gas line is typically galvanized steel, which can and does rust. However, viewing the underground gas line(s) would require digging, and HEI does not do any digging around the gas lines to determine their condition or the degree of rusting at the underground piping. Also, the use of specialized equipment to detect leaks is not included in the scope of this inspection, nor is determining the gas supply pressure or adequacy. If further investigation is desired to know the condition of the underground gas line(s), it is recommended that a plumber be contacted.

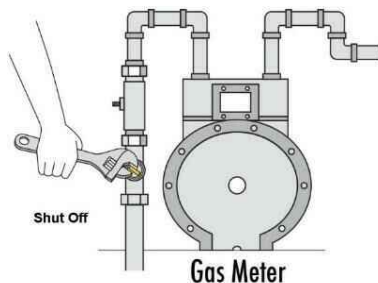

Gas Piping - Slight Rust:

The visible gas piping at the meter was observed to be slightly rusted at the joints and/or piping. The degree of the rust was not such that repairs are recommended, but if this condition concerns you, contact a plumber to remove the rust and paint the gas piping to prevent further deterioration.

I=Inspected

NI=Not Inspected

NP=Not Present

D=Deficient

I	NI	NP	D
---	----	----	---



I=Inspected

NI=Not Inspected

NP=Not Present

D=Deficient

I NI NP D

V. APPLIANCES

A. Dishwashers

Comments:

Functional:

The dishwasher was functioning and responded to the controls. The unit was run through a cycle at the time of the inspection and appeared to be operating properly.



1: No Anti-Siphon

The drain line under the sink was not equipped with an anti-siphon device, nor was it looped up so that the top of the loop is at least six inches above the entrance of the drain line into the disposal. It is recommended at least that the drain line be looped to prevent the water from the garbage disposal from siphoning back into the dishwasher, or an anti-siphon device installed.

Obtain Cost Estimate

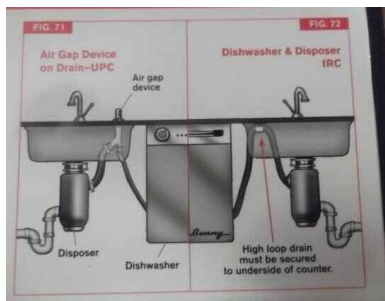

B. Food Waste Disposers

Comments:

Functional:

The disposal was operating and responded to the controls at the time of the inspection.



I=Inspected

NI=Not Inspected

NP=Not Present

D=Deficient

I NI NP D

C. Range Hood and Exhaust Systems

Comments:

Range vent not present:

The range vent hood was not present at the time of the inspection.

Contact Builder

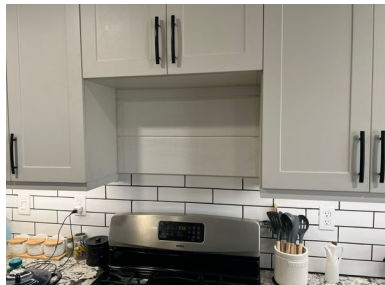

D. Ranges, Cooktops, and Ovens

Comments:

Ovens - Left/Right calibrated properly:

Both oven thermostats were checked and were properly calibrated. The thermostats were set at 350 degrees, and the ovens heated to within the allowable ± 25 degrees. The ovens were checked with an oven thermometer and found to heat to 340 degrees for the left oven, and 360 degrees for the right oven.



1: Electronic Igniter - burner nonfunctional

The electronic igniter for the left front burner was non-functional and needs to be repaired/replaced.

Obtain Cost Estimate



2: Interior Light - Nonfunctional

The interior light was non-functional. The cause could be a burned out light bulb, a defective switch, or related wiring.

Obtain Cost Estimate

I=Inspected

NI=Not Inspected

NP=Not Present

D=Deficient

I	NI	NP	D
---	----	----	---



E. Microwave Ovens

Comments:

Functional:

No items requiring repair were visible at the time of the inspection for the heating operation of the microwave. A cup of water was placed in the unit, and the microwave heated the water adequately. It is pointed out that the unit was not checked for microwave leakage.



F. Mechanical Exhaust Vents and Bathroom Heaters

Comments:

1: Exhaust Fan - Nonfunctional

Hall Bath

The exhaust fan was nonfunctional.

Obtain Cost Estimate



2: Vents - Not terminated outside

I=Inspected

NI=Not Inspected

NP=Not Present

D=Deficient

I NI NP D

We observed one or more bath vent fans that were not terminated outside. The most current building code requires the vent fan to be vented to the outside of the house, and it is recommended that the vent be extended to the outside of the house.

Obtain Cost Estimate



3: Exhaust Fan - Noisy

Half Bath

The exhaust fan was excessively noisy and should be repaired/replaced.

Obtain Cost Estimate



G. Garage Door Operators

Comments:

Functional - Autoreverse and sensors:

The garage door opener equipment was functional at the time of the inspection and opened/closed when the controls were operated. The auto-reverse mechanism was operational, and the sensitivity setting on the mechanism was adequate. Also, the infrared auto reverse mechanism was functional.

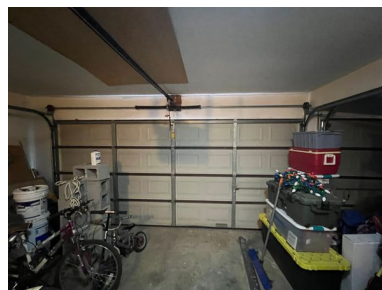

1: Opener - did not auto-reverse

The garage door opener did not stop the descent of the door when the door was subjected to a reasonable resisting pressure. This could cause possible personal injury or damage to house, and the opener is in need of

I=Inspected

NI=Not Inspected

NP=Not Present

D=Deficient

I NI NP D

adjustment. It is pointed out that the unit was equipped with the infra-red sensing safety device, and the device was operational at the time of the inspection.

Obtain Cost Estimate

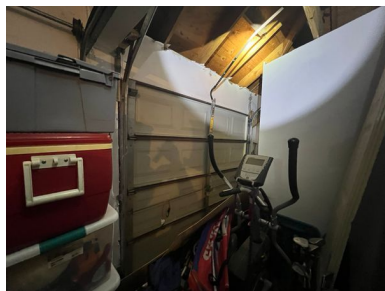

2: Not operating properly

The single door was not operating properly at the time of the inspection and would not open all the way. Further investigation is recommended by a service company.

Obtain Cost Estimate

Recommendation: Contact a qualified professional.



H. Dryer Exhaust Systems

Comments:

Dryer Vent:

The dryer vent appeared to be properly installed at the time of the inspection. It is pointed out that a portion of the dryer pipe was not visible where it entered the wall/ceiling. Also, dryer vents need to be cleaned periodically for safety reasons and to allow the dryer to operate properly.

Dryer vent - Dryer present:

The vent was connected to the dryer but was not tested. It is recommended that the vent be checked for an excess of lint and that it be cleaned if necessary. (Information)

I=Inspected

NI=Not Inspected

NP=Not Present

D=Deficient

I	NI	NP	D
---	----	----	---



I. Other

Comments:

Non Built-in Equipment - Not inspected:

It is pointed out that non built-in refrigerators, wine coolers, small refrigerators, clothes washers, and clothes dryers are not included in the scope of this inspection and were not checked. If further investigation is desired, it is recommended that a service company be contacted.

Further investigation is recommended

I=Inspected

NI=Not Inspected

NP=Not Present

D=Deficient

I NI NP D

VI. OPTIONAL SYSTEMS

A. Landscape Irrigation (Sprinkler) Systems

Comments:

Backflow Prevention Device - present:

A backflow prevention device was present and was equipped with the two water shut off valves on the water supply line to the sprinkler system.



Rain Sensor: Rain Sensor - Present -

It is currently required for automatic sprinkler systems to be equipped with a rain sensor device that will prevent the sprinkler system from operating during and shortly after a significant rain.

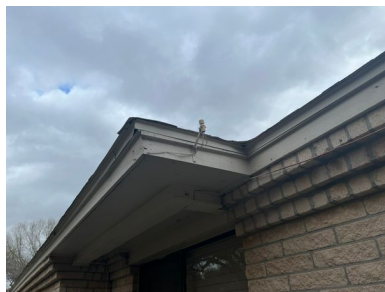

1: Control panel missing

The property had a backflow device and rain sensor but no control panel. Due to this condition the system was not able to operationally tested. Further investigation is recommended with the owners to determine the status of the system.

Obtain Cost Estimate

Recommendation: Contact a qualified professional.

I=Inspected

NI=Not Inspected

NP=Not Present

D=Deficient

I NI NP D

INFORMATION FROM HEDDERMAN ENGINEERING INC.

Closing Comments :

Opinions and comments stated in this report are based on the apparent performance of the items included within the scope of the inspection, at the time of the inspection. Performance standards are based on the knowledge gained through the experience and professional studies of the inspector. There is no warranty or guarantee, either expressed or implied, regarding the habitability, future performance, life, merchantability, and/or need for repair of any item inspected. It is recommended that a Home Warranty Policy be provided to protect the appliances and mechanical equipment against unforeseen breakdowns during the first year. Check with your agent for details.

Items identified in the report as Deficient and our Recommendations are provided in the above report. Many, but not all, recommendations are highlighted in bold red text. It is our intention, and your responsibility, that you follow up on these deficiencies and recommendations as part of your due diligence by contacting the appropriate service contractor(s) for Further Investigation, Obtain cost estimate, and/or Contact the builder. It is pointed out that other related and/or underlying conditions may be present, and which may not be apparent in our limited, visual inspection without further investigation by qualified service companies. It is emphasized how important it is for you if you intend to rely on our report(s), to continue to gather the in-depth information that will be obtained by further investigation with appropriate service technicians who will use their specialized knowledge of the component(s) and the related building codes along with their specialized diagnostic equipment to give you the TOTAL PICTURE of the condition of the property. Failure on your part to do your due diligence will constitute negligence on your part and will result in an incomplete body of knowledge upon which you base your decisions regarding this property. We recommend that your further investigations be done before the expiration of your option period and before closing on the property.

As an additional service, we recommend using a new tool we have on our website that can quickly turn your inspection report into an easy-to-read estimate of repairs for a nominal fee. These pricing reports from a third party company called Repair Pricer not only make the inspection report easy to understand in terms of dollars and cents, but they are also useful negotiation tools. Just visit the page below on our website and upload your report into Repair Pricer. If you have any questions when you receive your report, you can contact them at info@repairpricer.com
<http://www.heddermanengineering.com/repair-cost-estimates>