



Smith Group Property Inspections

Property Inspection Report



4613 Knoxville Street, Houston, TX 77051
Inspection prepared for: Michael Jolivet and Dwight Bazile

Date of Inspection: 12/30/2021 Time: 7:00AM
Age of Home: 2006 Size: 4000 sqft

Inspector: Brian Smith
License: #24130
13414 Hartland Lake Lane, Houston TX
Phone: 281-734-3118
Email: smith.inspections@outlook.com
www.getyourhouseinspected.com



Smith Group Property Inspections

PROPERTY INSPECTION REPORT FORM

Name of Client: Michael Jolivet and Dwight Bazile

Date of Inspection: 2021-12-30

Address of Inspected Property: 4613 Knoxville St Houston, TX 77051

Name of Inspector: Brian Smith

TREC License #: 24130

Name of Sponsor (if applicable): Brian Smith

TREC License #: 24130

PURPOSE OF INSPECTION

A real estate inspection is a visual survey of a structure and a basic performance evaluation of the systems and components of a building. It provides information regarding the general condition of a residence at the time the inspection was conducted. It is important that you carefully read ALL of this information. Ask the inspector to clarify any items or comments that are unclear.

RESPONSIBILITY OF THE INSPECTOR

This inspection is governed by the Texas Real Estate Commission (TREC) Standards of Practice (SOPs), which dictates the minimum requirements for a real estate inspection.

The inspector IS required to:

- * use this Property Inspection Report form for the inspection;
- * inspect only those components and conditions that are present, visible, and accessible at the time of the inspection;
- * indicate whether each item was inspected, not inspected, or not present;
- * indicate an item as Deficient (D) if a condition exists that adversely and materially affects the performance of a system or component OR constitutes a hazard to life, limb or property as specified by the SOPs; and
- * explain the inspectors findings in the corresponding section in the body of the report form.

The inspector IS NOT required to:

- * identify all potential hazards;
- * turn on decommissioned equipment, systems, utilities, or apply an open flame or light a pilot to operate any appliance;
- * climb over obstacles, move furnishings or stored items;
- * prioritize or emphasize the importance of one deficiency over another;
- * provide follow-up services to verify that proper repairs have been made; or
- * inspect system or component listed under the optional section of the SOPs (22 TAC 535.233).

RESPONSIBILITY OF THE CLIENT

While items identified as Deficient (D) in an inspection report DO NOT obligate any party to make repairs or take other actions, in the event that any further evaluations are needed, it is the responsibility of the client to obtain further evaluations and/or cost estimates from qualified service professionals regarding any items reported as Deficient (D). It is recommended that any further evaluations and/or cost estimates take place prior to the expiration of any contractual time limitations, such as option periods.

Please Note: Evaluations performed by service professionals in response to items reported as Deficient (D) on the report may lead to the discovery of additional deficiencies that were not present, visible, or accessible at the time of the inspection. Any repairs made after the date of the inspection may render information contained in this report obsolete or invalid.

REPORT LIMITATIONS

This report is provided for the benefit of the named client and is based on observations made by the named inspector on the date the inspection was performed (indicated above).

ONLY those items specifically noted as being inspected on the report were inspected.

This inspection IS NOT:

- * a technically exhaustive inspection of the structure, its systems, or its components and may not reveal all deficiencies;
- * an inspection to verify compliance with any building codes;
- * an inspection to verify compliance with manufacturers installation instructions for any system or component and DOES NOT imply insurability or warrantability of the structure or its components.



NOTICE CONCERNING HAZARDOUS CONDITIONS, DEFICIENCIES, AND CONTRACTUAL AGREEMENTS

Conditions may be present in your home that did not violate building codes or common practices in effect when the home was constructed but are considered hazardous by today's standards. Such conditions that were part of the home prior to the adoption of any current codes prohibiting them may not be required to be updated to meet current code requirements. However, if it can be reasonably determined that they are present at the time of the inspection, the potential for injury or property loss from these conditions is significant enough to require inspectors to report them as Deficient (D). Examples of such hazardous conditions include:

- * malfunctioning, improperly installed, or missing ground fault circuit protection (GFCI) devices and arc-fault (AFCI) devices;
- * ordinary glass in locations where modern construction techniques call for safety glass;
- * malfunctioning or lack of fire safety features such as smoke alarms, fire-rated doors in certain locations, and functional emergency escape and rescue openings in bedrooms;
- * malfunctioning carbon monoxide alarms;
- * excessive spacing between balusters on stairways and porches;
- * improperly installed appliances;
- * improperly installed or defective safety devices;
- * lack of electrical bonding and grounding; and
- * lack of bonding on gas piping, including corrugated stainless steel tubing (CSST).

Please Note: items identified as Deficient (D) in an inspection report DO NOT obligate any party to make repairs or take other actions. The decision to correct a hazard or any deficiency identified in an inspection report is left up to the parties to the contract for the sale or purchase of the home.

This property inspection report may include an inspection agreement (contract), addenda, and other information related to property conditions.

INFORMATION INCLUDED UNDER "ADDITIONAL INFORMATION PROVIDED BY INSPECTOR", OR PROVIDED AS AN ATTACHMENT WITH THE STANDARD FORM, IS NOT REQUIRED BY THE COMMISSION AND MAY CONTAIN CONTRACTUAL TERMS BETWEEN THE INSPECTOR AND YOU, AS THE CLIENT. THE COMMISSION DOES NOT REGULATE CONTRACTUAL TERMS BETWEEN PARTIES. IF YOU DO NOT UNDERSTAND THE EFFECT OF ANY CONTRACTUAL TERM CONTAINED IN THIS SECTION OR ANY ATTACHMENTS, CONSULT AN ATTORNEY.

ADDITIONAL INFORMATION PROVIDED BY INSPECTOR



Report Identification: 4613 Knoxville St - Houston, TX 77051

I=Inspected NI=Not Inspected NP=Not Present D=Deficient

I NI NP D

Exterior Notes:

Proper drainage and soil moisture contents should be maintained around the foundation to help minimize future foundation problems.

Underground drainage systems are not inspected.

These should be maintained for proper drainage.

Grading and drainage are probably the most significant aspects of a property, simply because of the direct and indirect damage that moisture can have on structures.

More damage has probably resulted from moisture and expansive soils than from most natural disasters.

Also, there should be gutters and downspouts with splash blocks that discharge away from the building.

In the past, we have discovered evidence of moisture intrusion inside structures when it was raining that would not have been apparent otherwise.

Minor settlement or hairline cracks in drives, walks or even foundations are normal to properties of any age.

They should, however, be monitored for expansion and sealed as necessary.

Also tripping hazards may occur from uneven or gaps in pavement, this should be addressed as needed.

As with all areas of the house, we recommend that you carefully examine the roof immediately prior to closing the deal.

Note that most roofs are walked by inspector.

However some roofs may not be walked due to conditions existing which could be dangerous to the inspector, such as too high, or too steep a roofing pitch.

Rain could make the surfaces of the roof too slippery to walk on safely.

This may require the roof to be observed from lower portions of the roof, the edge of the roof or the ground with binoculars.

As such, our inspection may be considered a limited inspection with observations and conclusions drawn from what was visible using a limited view of the roofing materials.

Note that any siding, but especially composition or hardboard siding must be closely monitored.

A classic example is the older style Louisiana Pacific siding, where the failure and deterioration provided grounds for a class action lawsuit.

Even modern composition siding and, especially, trim, is particularly vulnerable to moisture damage.

All seams must remain sealed and paint must be applied periodically (especially the lower courses at ground level).

It is imperative that continued moisture be kept from it, especially from sprinklers, rain splash back or wet grass.

Swelling and deterioration may otherwise result.

Client: Michael Jolivet and Dwight Bazile



Report Identification: 4613 Knoxville St - Houston, TX 77051

I=Inspected NI=Not Inspected NP=Not Present D=Deficient

I NI NP D

Vegetation too close to the home can contribute to damage through root damage to the foundation, branches abrading the roof and siding, and leaves providing a pathway for moisture and insects into the home.

Although rails are not required around drop-offs less than 30, consider your own personal needs and those of your family and guests.

By todays standards, spindles at decks and steps should be spaced no more than 4 apart for the safety of children.

I. STRUCTURAL SYSTEMS

☒☐☐☐ A. Foundations

Type of Foundation(s): Post Tension

Comments: Slab-on-Grade

Structural movement and/or settling noted; however, the foundation is supporting the structure at this time.

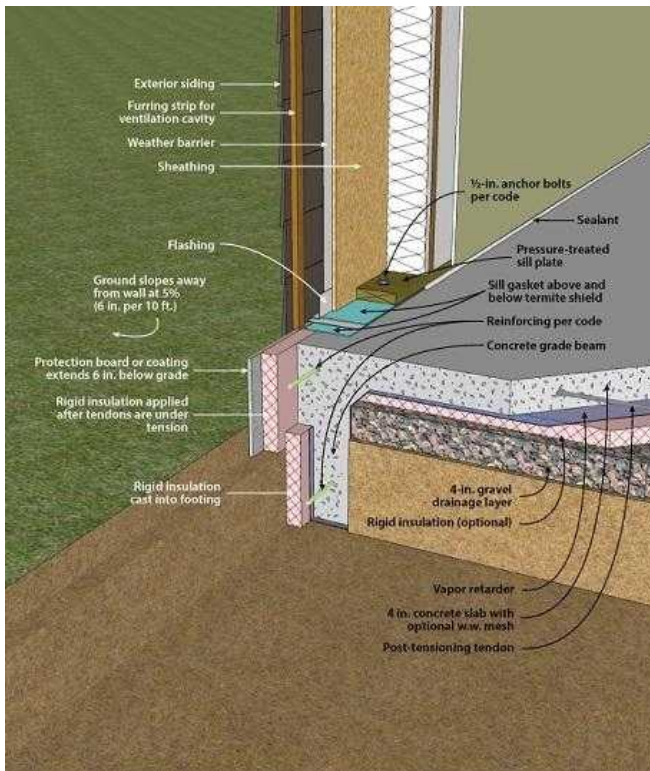

Client: Michael Jolivet and Dwight Bazile



Report Identification: 4613 Knoxville St - Houston, TX 77051

I=Inspected NI=Not Inspected NP=Not Present D=Deficient

I	NI	NP	D
---	----	----	---



B. Grading and Drainage

Comments: Moderate slope,

Soil / mulch too high at foundation.

Soil (or mulch) too high at foundation can potentially promote pest intrusion.

It is recommended that at least 4 of foundation be visible.

Correction recommended by qualified contractor.

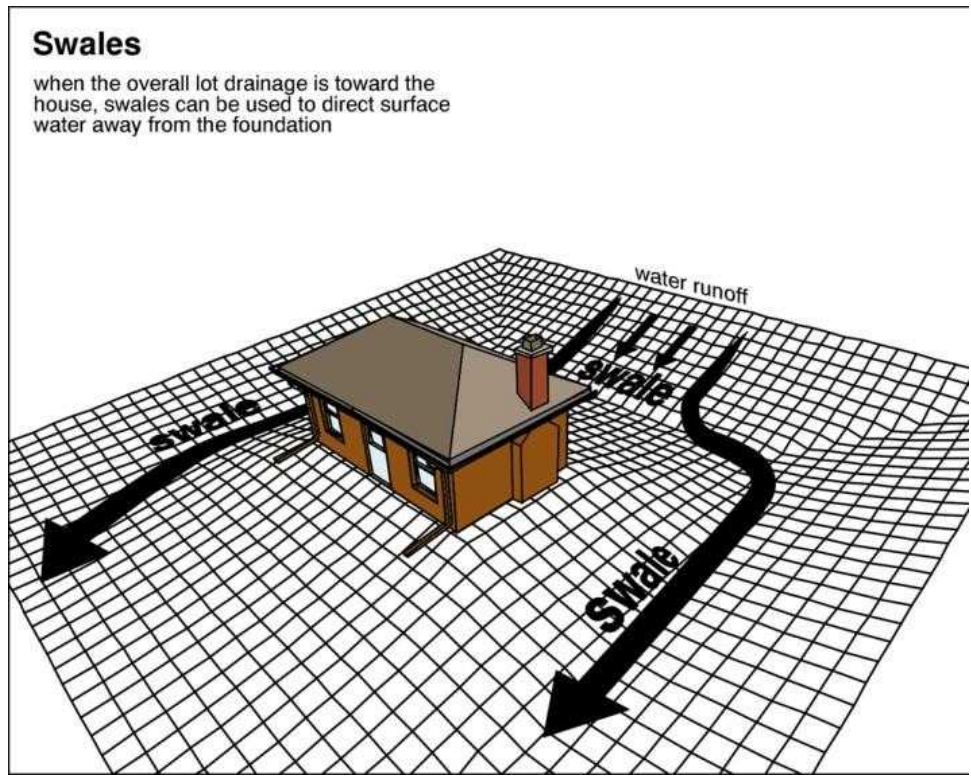

Client: Michael Jolivet and Dwight Bazile

I=Inspected NI=Not Inspected NP=Not Present D=Deficient

I NI NP D

B. Grading and Drainage (continued)



C. Roof Covering Materials

Types of Roof Covering: Gable

Viewed from: Ground level with drone

Comments: Asphalt shingle

Roof covering materials appeared to be performing as intended at time of inspection.

After observing the interior of the structure, evidences of roof leaks were not visible.

The absence of evidences of roof leaks does not guarantee that roof leaks were not present; rather, that no evidences of leaking were visible at the time of the inspection.



Report Identification: 4613 Knoxville St - Houston, TX 77051

I=Inspected NI=Not Inspected NP=Not Present D=Deficient

I NI NP D

C. Roof Covering Materials (continued)



Client: Michael Jolivet and Dwight Bazile



Report Identification: 4613 Knoxville St - Houston, TX 77051

I=Inspected NI=Not Inspected NP=Not Present D=Deficient

I NI NP D

C. Roof Covering Materials (continued)



Client: Michael Jolivet and Dwight Bazile



Report Identification: 4613 Knoxville St - Houston, TX 77051

I=Inspected NI=Not Inspected NP=Not Present D=Deficient

I NI NP D

C. Roof Covering Materials (continued)



Client: Michael Jolivet and Dwight Bazile



Report Identification: 4613 Knoxville St - Houston, TX 77051

I=Inspected NI=Not Inspected NP=Not Present D=Deficient

I NI NP D

C. Roof Covering Materials (continued)



Client: Michael Jolivet and Dwight Bazile

Report Identification: 4613 Knoxville St - Houston, TX 77051

I=Inspected NI=Not Inspected NP=Not Present D=Deficient

I	NI	NP	D
---	----	----	---

D. Roof Structures and Attics

Viewed from: In the attic
Approximate Average Depth of Insulation: 7 - 12
Comments: Rafter

Observed no insulation / weatherstripping at attic access door.

Correction recommended by qualified contractor to minimize opportunity for heating / cooling loss at attic access door.



Client: Michael Jolivet and Dwight Bazile

Report Identification: 4613 Knoxville St - Houston, TX 77051

I=Inspected NI=Not Inspected NP=Not Present D=Deficient

I NI NP D

E. Walls (Interior and Exterior)

Comments: Drywall / Fiber Cement,

Damaged wall covering (exterior) observed.

a. Wood rot observed (multiple areas).

Correction recommended to minimize possibility of moisture / pest intrusion.



I=Inspected NI=Not Inspected NP=Not Present D=Deficient

I NI NP D

E. Walls (Interior and Exterior) (continued)

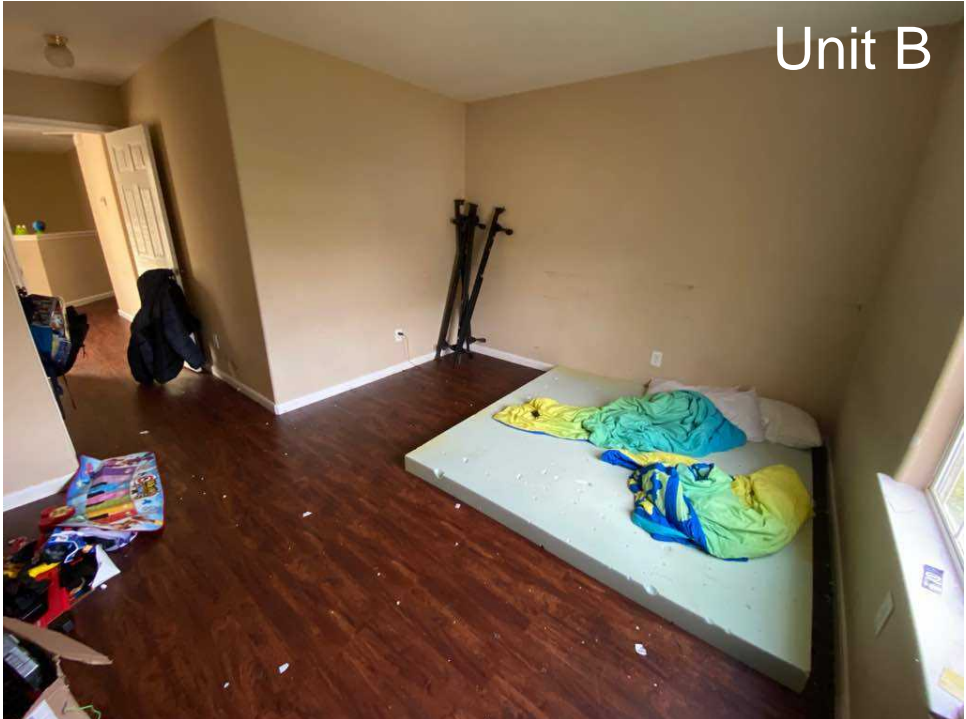

Client: Michael Jolivet and Dwight Bazile

I=Inspected NI=Not Inspected NP=Not Present D=Deficient

I	NI	NP	D
---	----	----	---

E. Walls (Interior and Exterior) (continued)

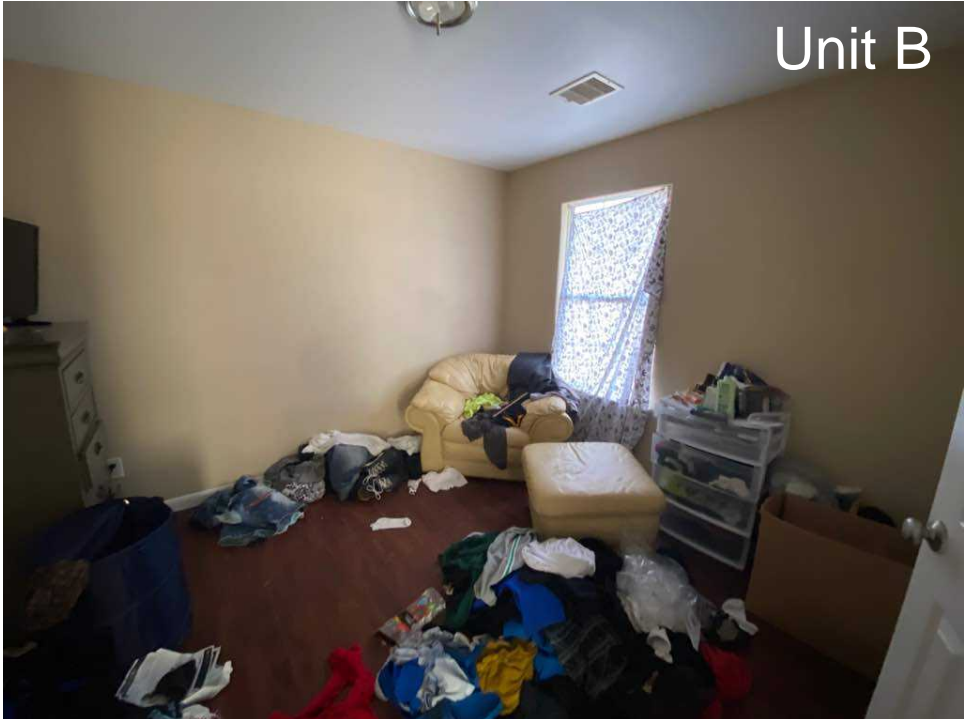

Client: Michael Jolivet and Dwight Bazile

I=Inspected NI=Not Inspected NP=Not Present D=Deficient

I	NI	NP	D
---	----	----	---

E. Walls (Interior and Exterior) (continued)



Client: Michael Jolivet and Dwight Bazile

I=Inspected NI=Not Inspected NP=Not Present D=Deficient

I	NI	NP	D
---	----	----	---

E. Walls (Interior and Exterior) (continued)

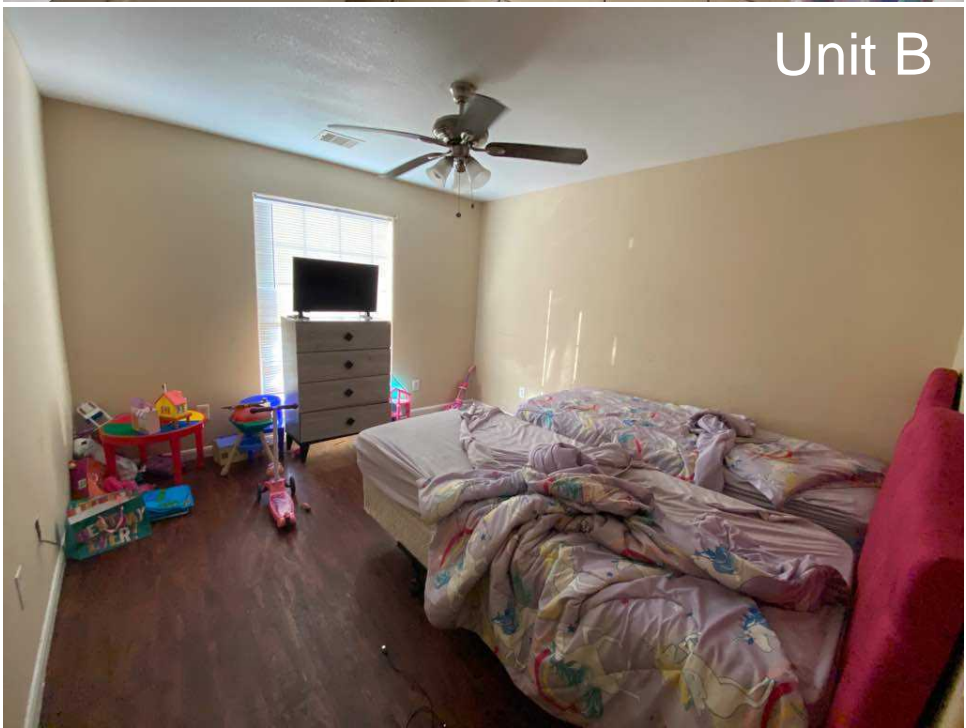

Client: Michael Jolivet and Dwight Bazile

I=Inspected NI=Not Inspected NP=Not Present D=Deficient

I NI NP D

E. Walls (Interior and Exterior) (continued)



Report Identification: 4613 Knoxville St - Houston, TX 77051

I=Inspected NI=Not Inspected NP=Not Present D=Deficient

I NI NP D

E. Walls (Interior and Exterior) (continued)

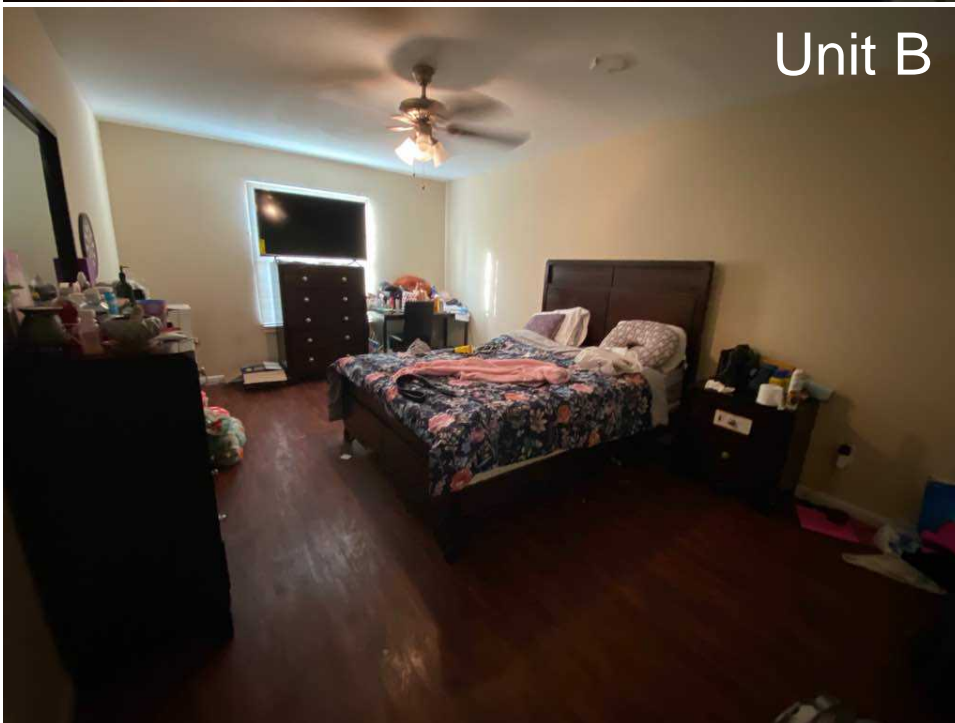

I=Inspected NI=Not Inspected NP=Not Present D=Deficient

I NI NP D

E. Walls (Interior and Exterior) (continued)

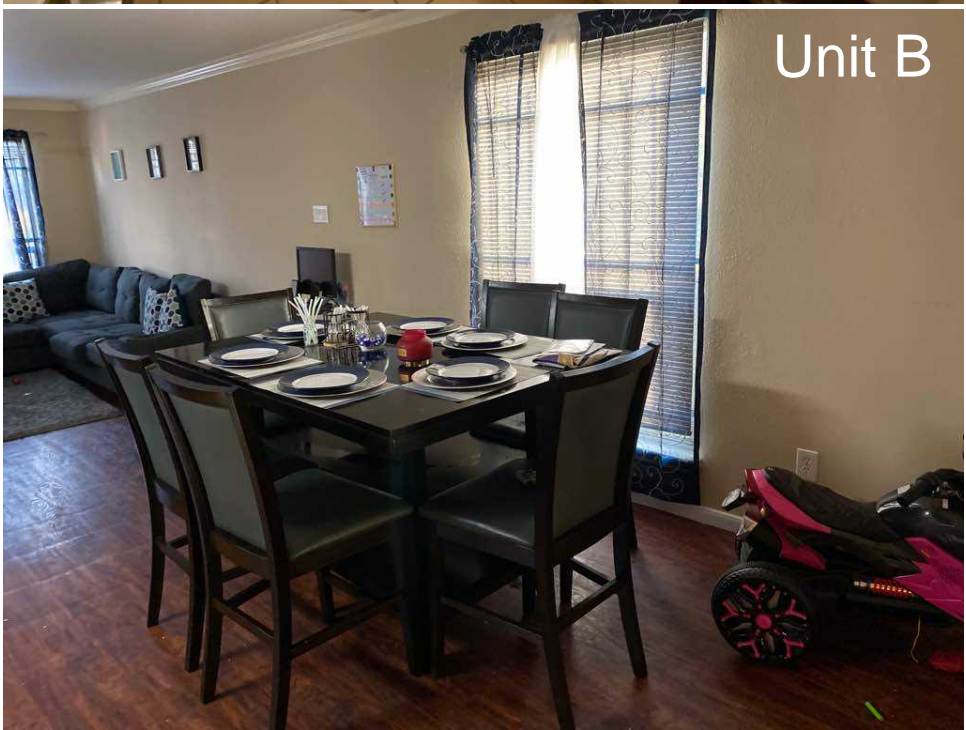
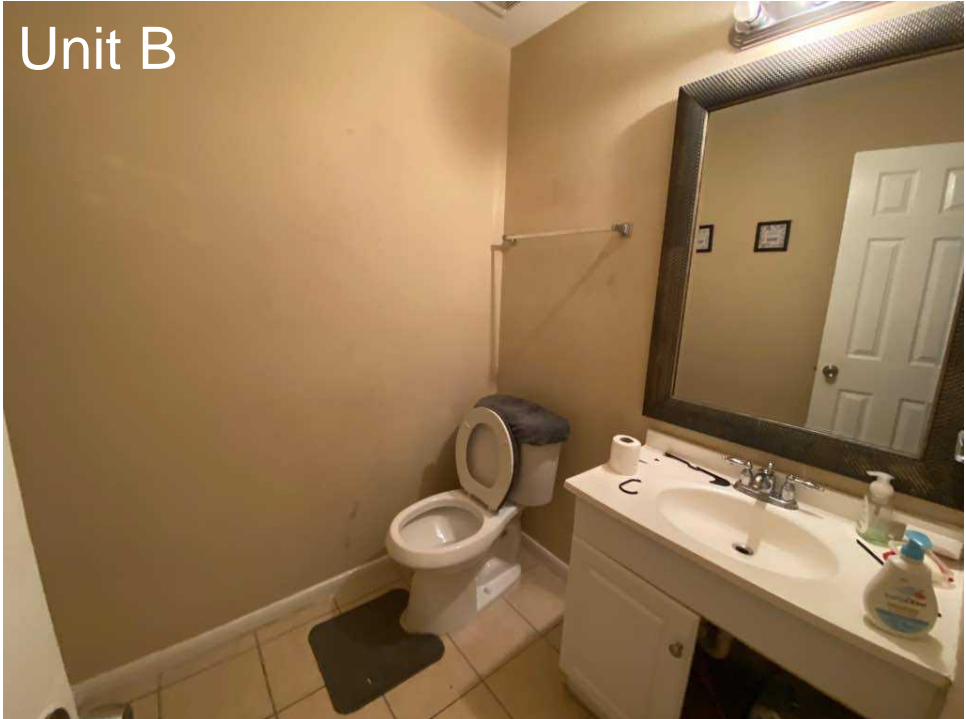

Client: Michael Jolivet and Dwight Bazile

I=Inspected NI=Not Inspected NP=Not Present D=Deficient

I NI NP D

E. Walls (Interior and Exterior) (continued)

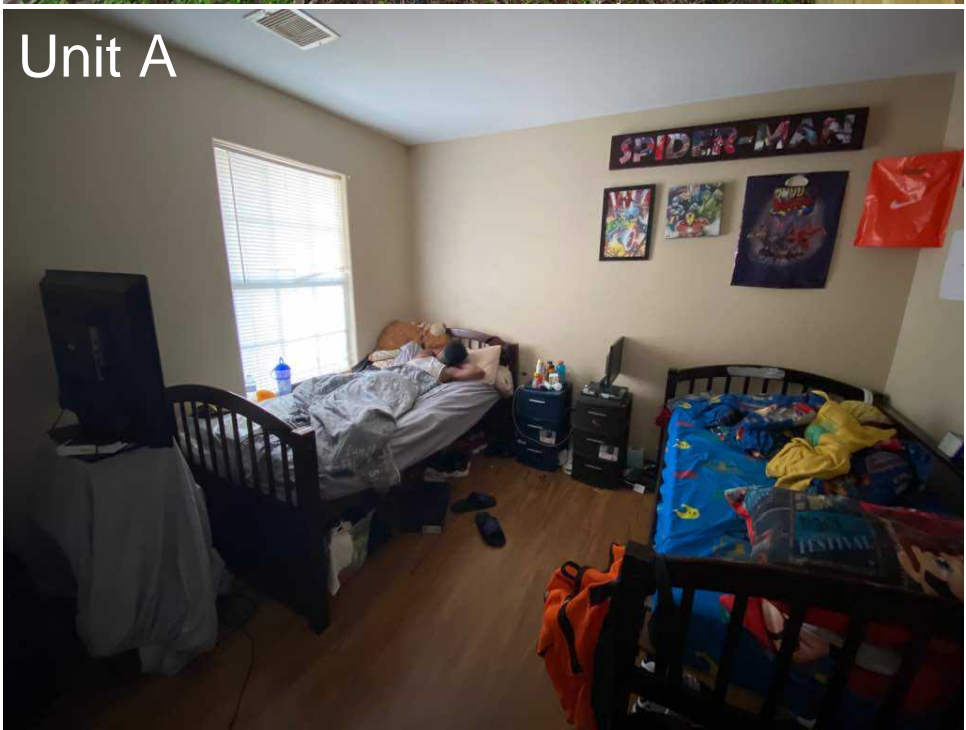

Client: Michael Jolivet and Dwight Bazile

I=Inspected NI=Not Inspected NP=Not Present D=Deficient

I NI NP D

E. Walls (Interior and Exterior) (continued)

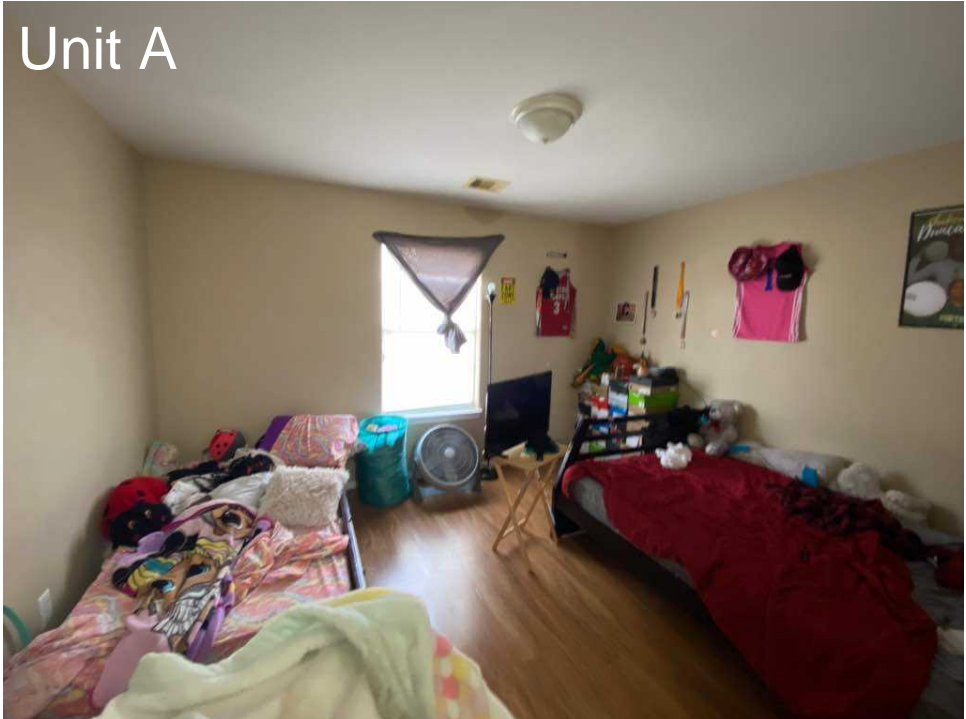

Client: Michael Jolivet and Dwight Bazile

I=Inspected NI=Not Inspected NP=Not Present D=Deficient

I NI NP D

E. Walls (Interior and Exterior) (continued)

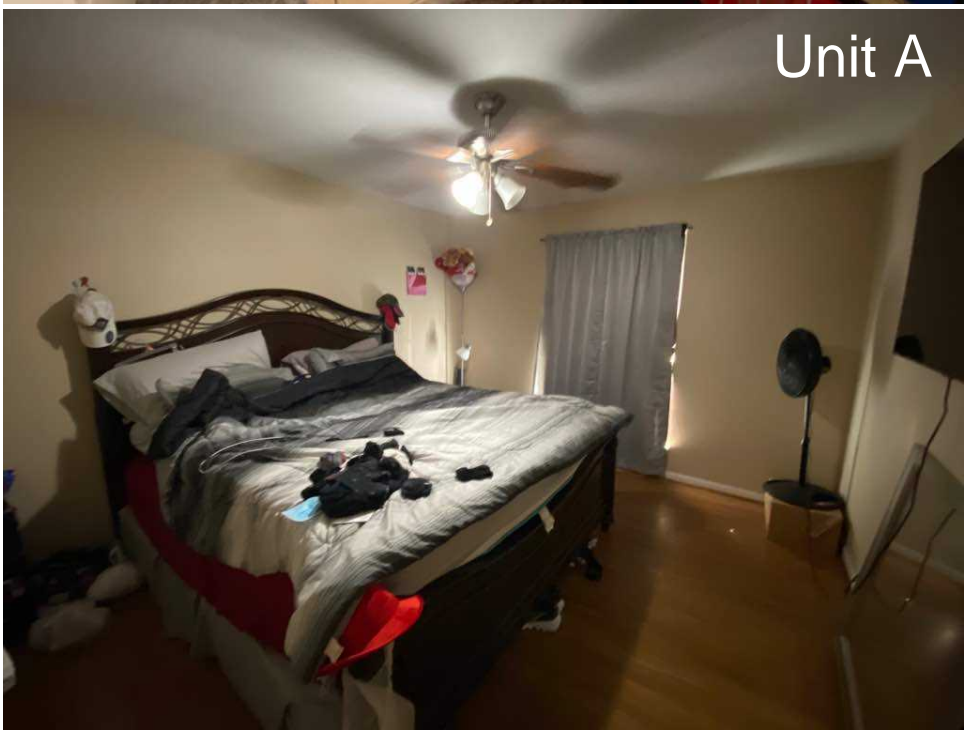

Client: Michael Jolivet and Dwight Bazile

I=Inspected NI=Not Inspected NP=Not Present D=Deficient

I NI NP D

E. Walls (Interior and Exterior) (continued)



Report Identification: 4613 Knoxville St - Houston, TX 77051

I=Inspected NI=Not Inspected NP=Not Present D=Deficient

I NI NP D

E. Walls (Interior and Exterior) (continued)

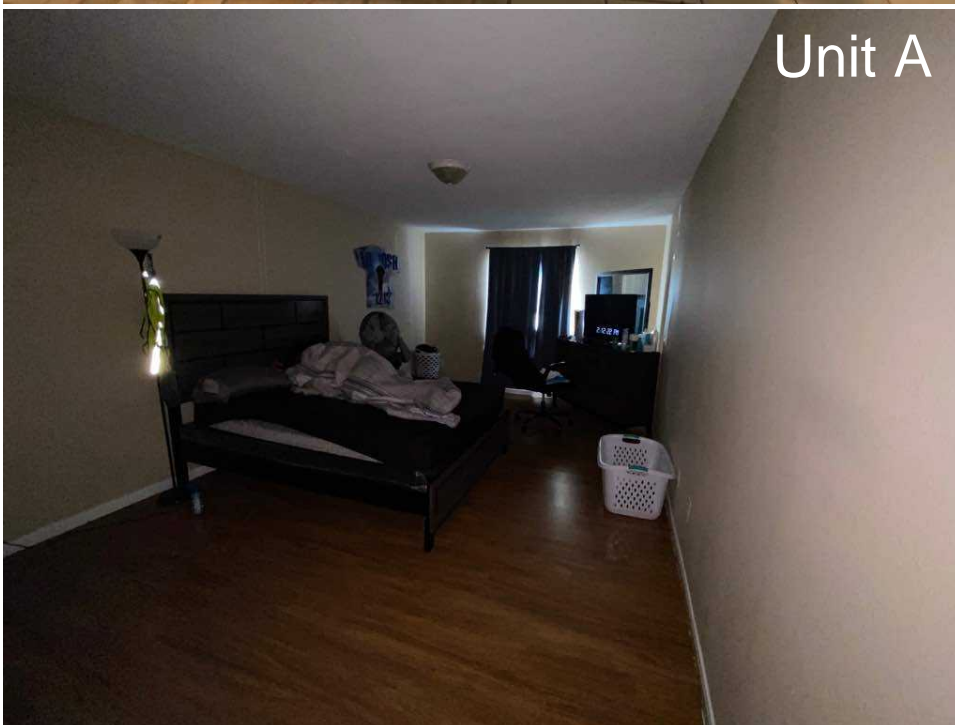

Report Identification: 4613 Knoxville St - Houston, TX 77051

I=Inspected NI=Not Inspected NP=Not Present D=Deficient

I	NI	NP	D
---	----	----	---

E. Walls (Interior and Exterior) (continued)



F. Ceilings

Comments: Drywall,

Observed moisture stains at ceiling (active leak).

Moisture stains can indicate moisture intrusion and / or structural deficiency.

Further evaluation and correction recommended by qualified contractor.

I=Inspected NI=Not Inspected NP=Not Present D=Deficient

I NI NP D

F. Ceilings (continued)



G. Floors

Comments: Tile, Laminate,
Floors appeared to operate as intended at time of inspection.

Client: Michael Jolivet and Dwight Bazile



Report Identification: 4613 Knoxville St - Houston, TX 77051

I=Inspected NI=Not Inspected NP=Not Present D=Deficient

I	NI	NP	D
---	----	----	---

H. Doors (Interior and Exterior)

Comments: Wood,

1. Burglar bars (keyed) observed at doors.

Keyed burglar inhibit exit in emergency situations.

Further evaluation and correction recommended by qualified contractor.

2. Missing doorstop observed.

Correction recommended by qualified contractor to avoid wall damage.



Client: Michael Jolivet and Dwight Bazile

Report Identification: 4613 Knoxville St - Houston, TX 77051

I=Inspected NI=Not Inspected NP=Not Present D=Deficient

I NI NP D

H. Doors (Interior and Exterior) (continued)



☒ ☐ ☐ ☒

I. Windows

Comments: Single hung window,

Burglar bars observed at windows.

Keyed burglar inhibit exit in emergency situations.

Further evaluation and correction recommended by qualified contractor.

I=Inspected NI=Not Inspected NP=Not Present D=Deficient

I NI NP D

I. Windows (continued)

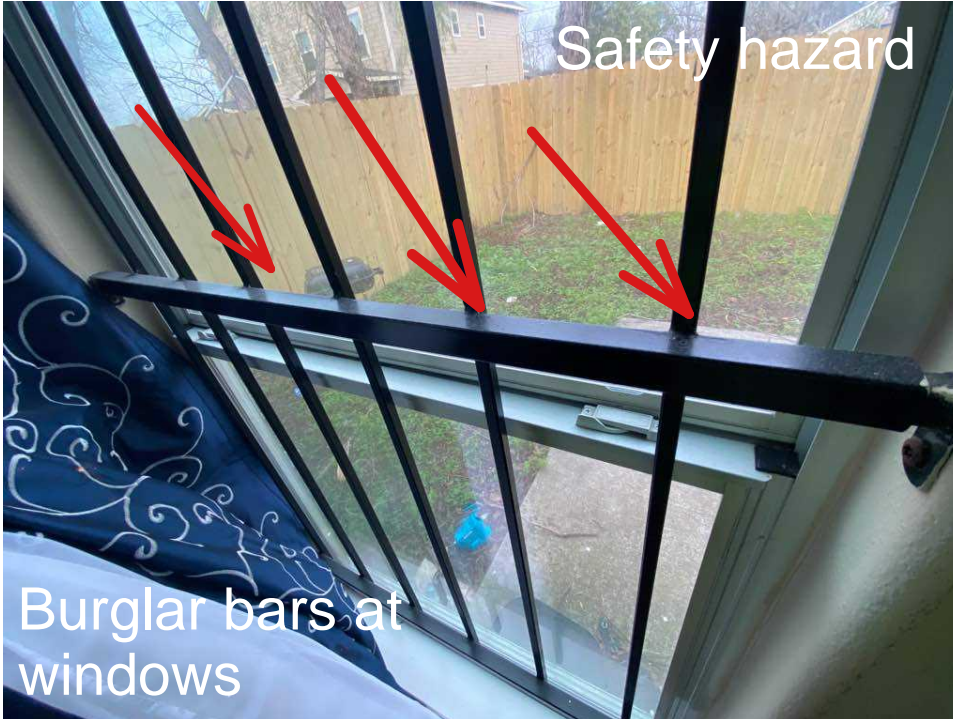

☒☐☐☒ J. Stairways (Interior and Exterior)

Comments: Wood stairs with wood handrails,

Stair handrails loose (moves unsteadily from side to side).

Correction recommended by qualified contractor.

I=Inspected NI=Not Inspected NP=Not Present D=Deficient

I NI NP D

J. Stairways (Interior and Exterior) (continued)

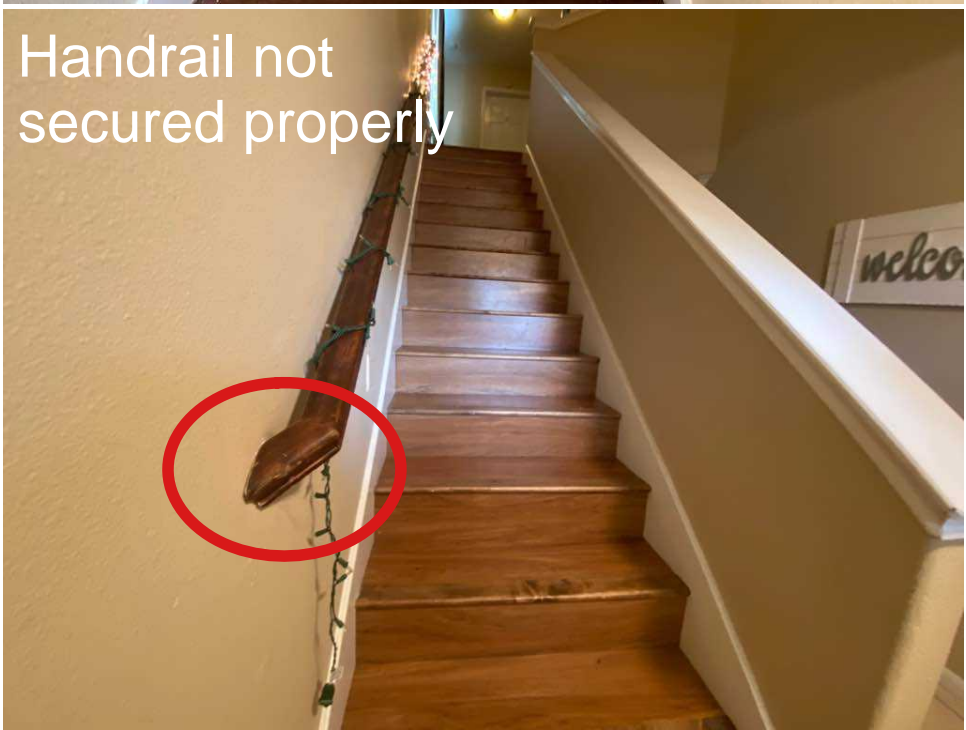

Client: Michael Jolivet and Dwight Bazile



Report Identification: 4613 Knoxville St - Houston, TX 77051

I=Inspected NI=Not Inspected NP=Not Present D=Deficient

I NI NP D

K. Fireplaces and Chimneys

Comments:

L. Porches, Balconies, Decks, and Carports

Comments: Fiber Cement,
Front Porch performed as intended at time of inspection.

Back patio performed as intended at time of inspection.

M. Fences / Gates

Comments: Wood Fence,

Observed damaged fence pickets / posts.

Damaged fence pickets / posts can be safety issue.

Recommend further evaluation & correction by qualified contractor.



Client: Michael Jolivet and Dwight Bazile

Report Identification: 4613 Knoxville St - Houston, TX 77051

I=Inspected NI=Not Inspected NP=Not Present D=Deficient

I NI NP D

M. Fences / Gates (continued)



N. Other
Comments:



Report Identification: 4613 Knoxville St - Houston, TX 77051

I=Inspected NI=Not Inspected NP=Not Present D=Deficient

I NI NP D

Electrical Notes:

Note that only accessible GFCI outlets are tested and tripped.

Some baths may have non-GFCI outlets which are protected by a GFCI outlet in a remote area (garage, another bath, etc.).

Also, note that most electricians agree that smoke detectors are good for about 5 years, and the breakers in your panel box have an expected life of about 20 years.

Therefore, if this home was built more than 20 years previous, consider having the panel box and breakers evaluated by a licensed electrician, as an overheated breaker can result in a structural fire.

If your home does not have a carbon monoxide detector (few do!), we recommend making that investment.

Any home that has a Bulldog Pushmatic, Sylvania, Zinsco or Federal Pacific Electric panel should have it evaluated by a licensed electrician, as these older types of panels and breakers have been known to overheat and cause house fires.

Unable to inspect underground services.

II. ELECTRICAL SYSTEMS

A. Service Entrance and Panels

Comments: Copper and Aluminum,

1. No anti-oxidant paste observed at main electrical aluminum cables in panel.

Anti oxidant paste is recommended for aluminum cables because (without the paste) aluminum can overheat & become fire hazard.

Further evaluation & correction recommended by qualified contractor.

2. Main electrical panel not sealed at interface with exterior wall covering (at time of inspection).

Panel/service boxes should be sealed on top and both sides to minimize the possibility of moisture / pest intrusion.

Correction recommended by qualified contractor.

3. Non covered electrical wiring observed (Unit B).

Correction recommended by qualified contractor

Client: Michael Jolivet and Dwight Bazile

I=Inspected NI=Not Inspected NP=Not Present D=Deficient

I NI NP D

Circuit Breaker Wiring Diagram

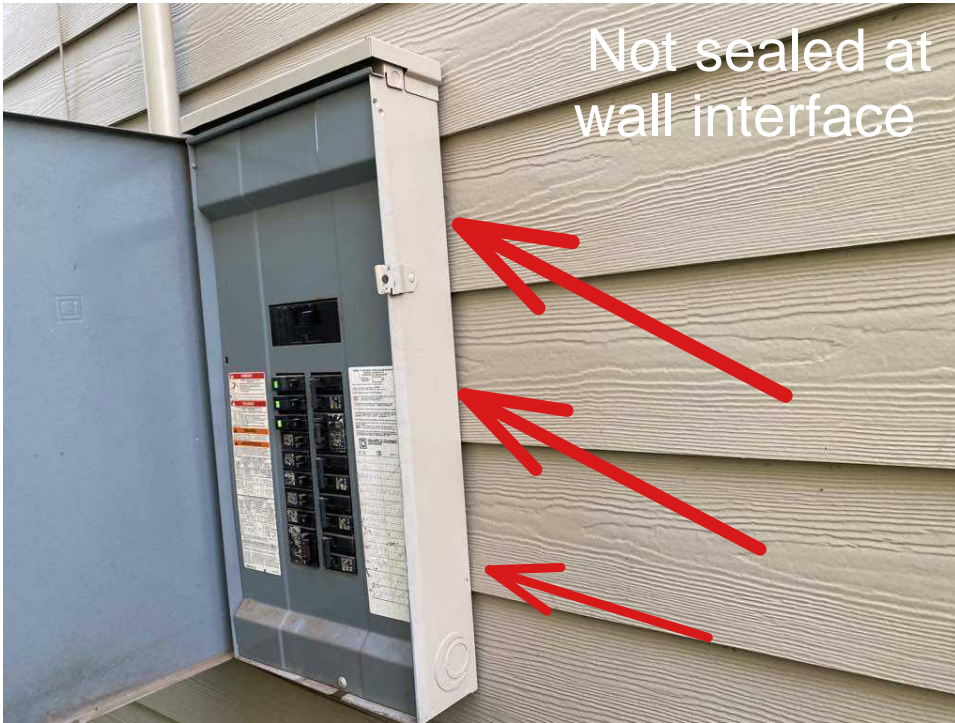
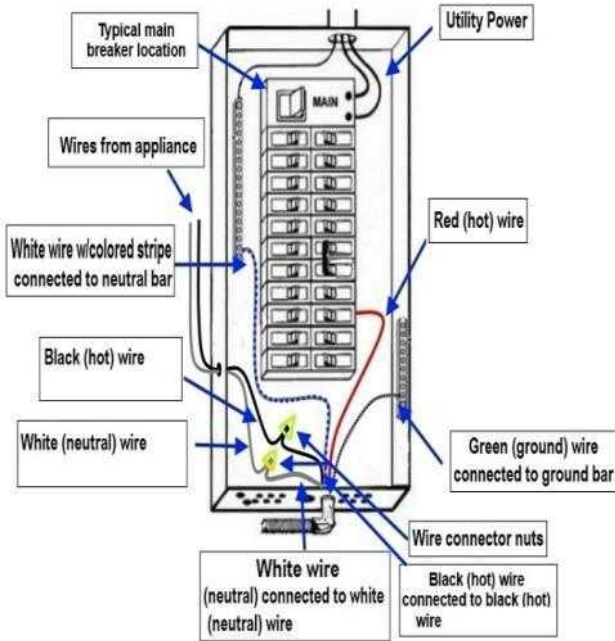

Client: Michael Jolivet and Dwight Bazile

I=Inspected NI=Not Inspected NP=Not Present D=Deficient

I NI NP D

A. Service Entrance and Panels (continued)

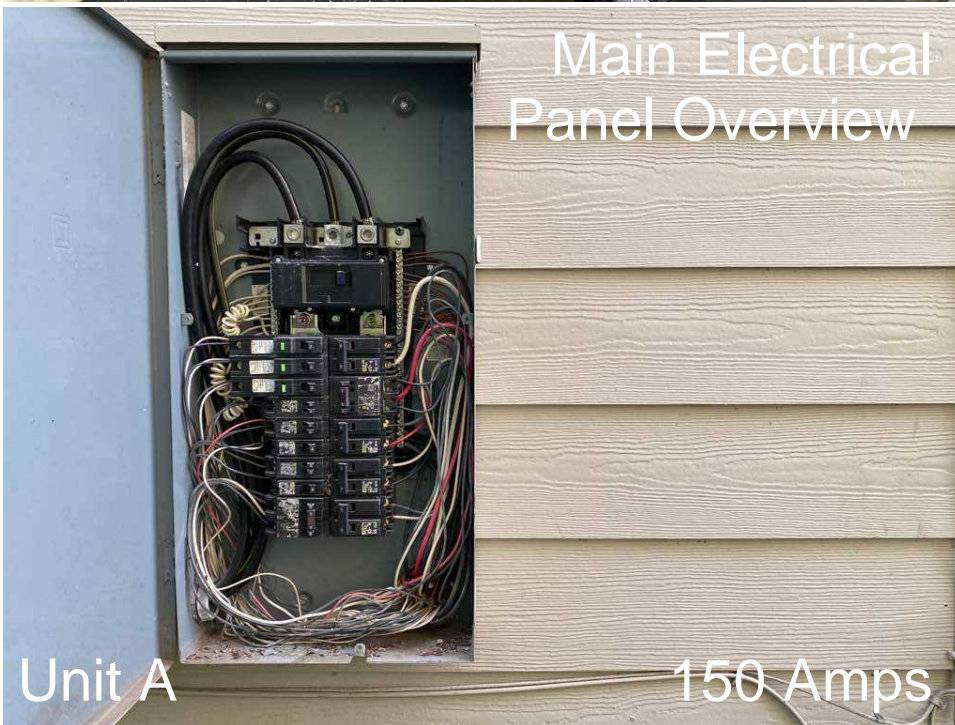
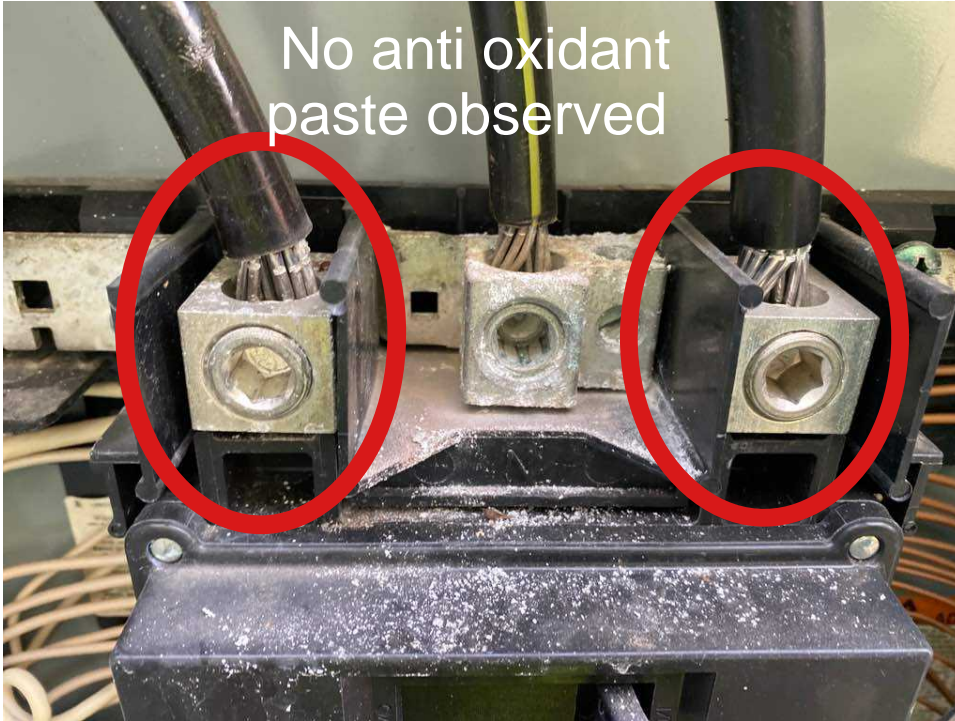

Client: Michael Jolivet and Dwight Bazile

Report Identification: 4613 Knoxville St - Houston, TX 77051

I=Inspected NI=Not Inspected NP=Not Present D=Deficient

I NI NP D

A. Service Entrance and Panels (continued)

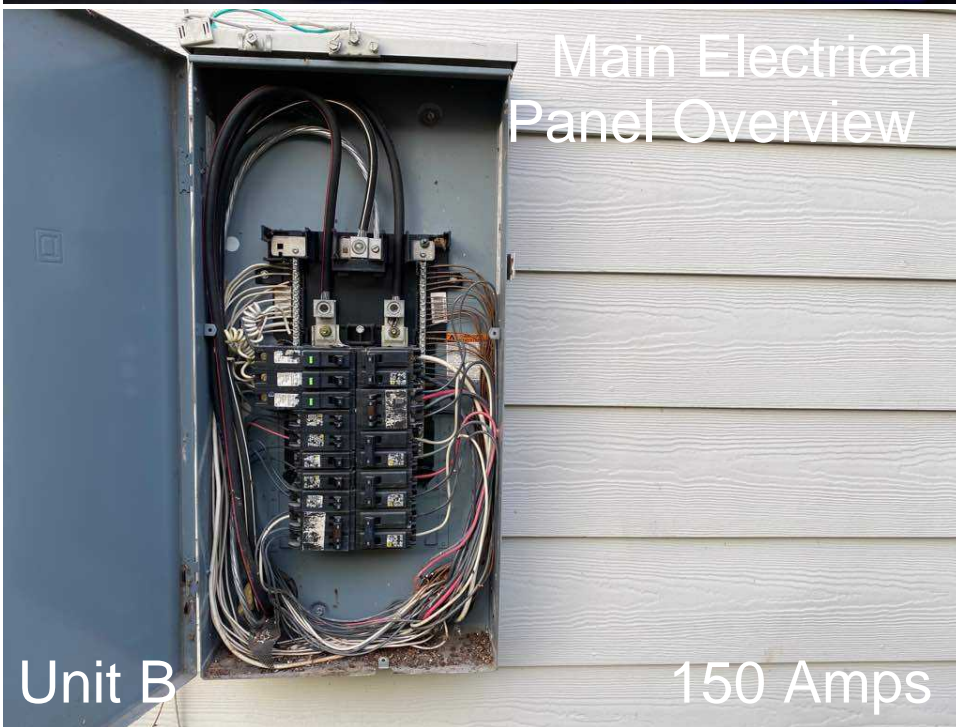

Client: Michael Jolivet and Dwight Bazile

I=Inspected NI=Not Inspected NP=Not Present D=Deficient

I NI NP D

A. Service Entrance and Panels (continued)

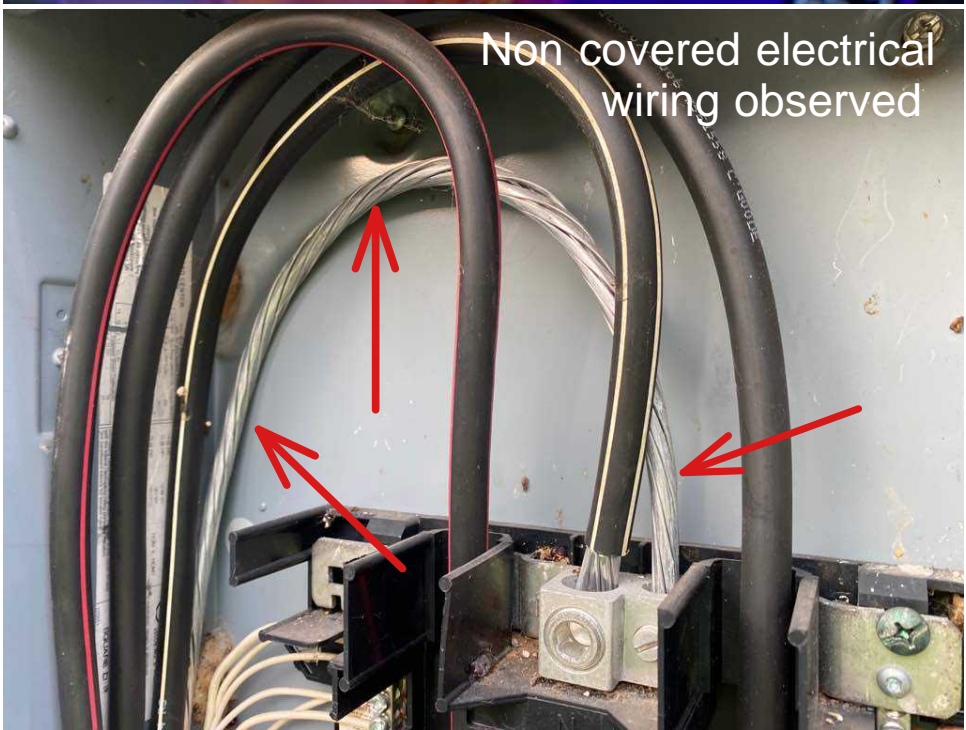

Client: Michael Jolivet and Dwight Bazile

Report Identification: 4613 Knoxville St - Houston, TX 77051

I=Inspected NI=Not Inspected NP=Not Present D=Deficient

I NI NP D

Amps (Main Panel) 150 Amps, 150 Amps

Location (Main Panel) Exterior, Exterior

B. Branch Circuits, Connected Devices, and Fixtures

Type of Wiring: Copper

Comments: Copper

Electrical covers missing from outlets (multiple).

Correction recommended by qualified contractor.

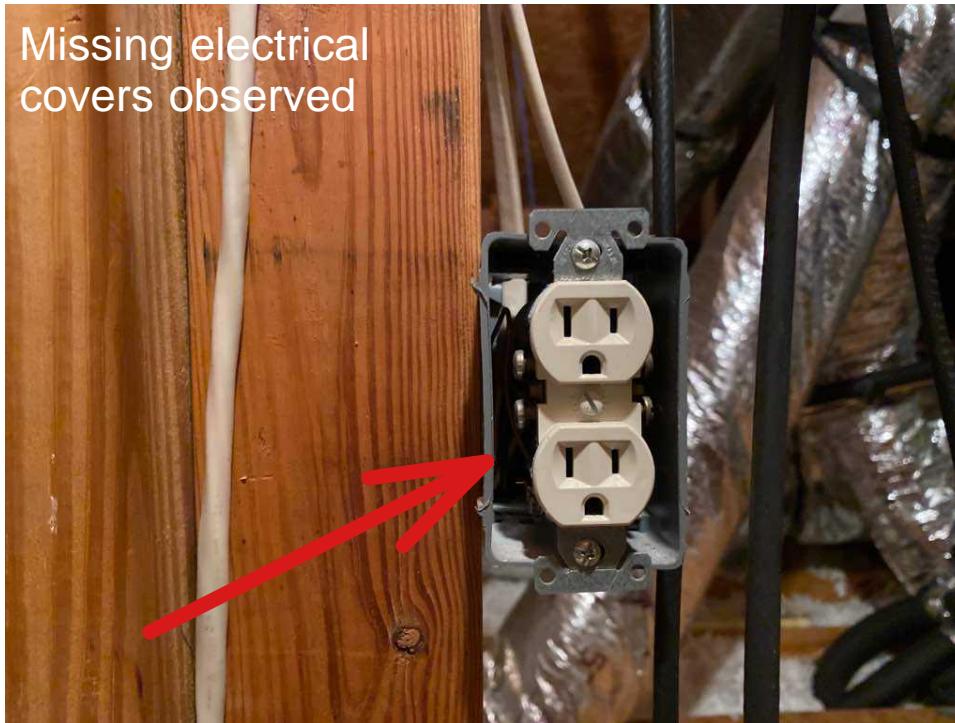

I=Inspected NI=Not Inspected NP=Not Present D=Deficient

I NI NP D

C. AFCI (Arc Fault Circuit Interrupter)

Comments: Arc Fault Circuit Interrupter: Required at by current building standards, AFCI's appeared to operate as intended at time of inspection.

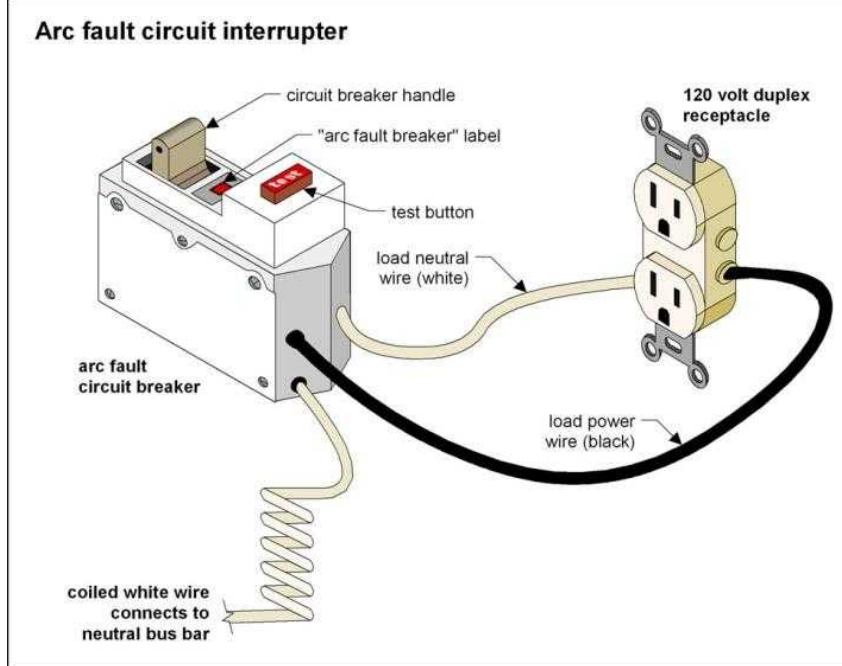

Client: Michael Jolivet and Dwight Bazile

I=Inspected NI=Not Inspected NP=Not Present D=Deficient

I NI NP D

C. AFCI (Arc Fault Circuit Interrupter) (continued)



D. GFCI (Ground Fault Circuit Interrupter)

Comments: GFCIs (Required) Locations: Kitchen, Bathrooms, & Garage, Proper GFCIs observed at time of inspection.

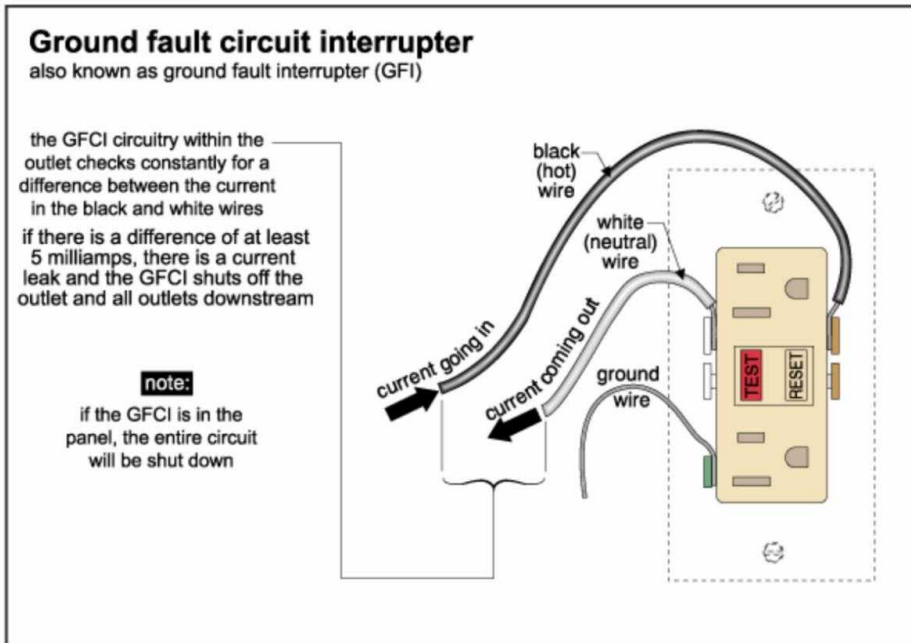

Client: Michael Jolivet and Dwight Bazile

I=Inspected NI=Not Inspected NP=Not Present D=Deficient

I NI NP D

D. GFCI (Ground Fault Circuit Interrupter) (continued)



☒☐☐☒ E. Smoke / Carbon Monoxide Detectors

Comments: Kiddie,

Observed batteries needing replacement in smoke detectors (multiple).

Correction recommended by qualified contractor to ensure proper safety.



Client: Michael Jolivet and Dwight Bazile

I=Inspected NI=Not Inspected NP=Not Present D=Deficient

I	NI	NP	D
---	----	----	---

F. Doorbell

Comments: Exterior (front entrance to property),
Doorbell operating as intended at time of inspection.



G. Light Fixtures

Comments: Interior / Exterior,
Light fixtures operating as intended at time of inspection.

Heating & Air Conditioning Notes:

The heating, ventilation, air conditioning and cooling system (often referred to as HVAC) is the climate control system for the structure.

The goal of these systems is to keep the occupants at a comfortable level while maintaining indoor air quality, ventilation while keeping maintenance costs at a minimum.

The HVAC system is usually powered by electricity and natural gas, but can also be powered by other sources such as butane, oil, propane, solar panels, or wood.

The inspector will test the heating and air conditioner using the thermostat or other controls.

Units are not inspected for cleanliness and/or rust.

Recommend proper maintenance of the unit and filter.

Client: Michael Jolivet and Dwight Bazile



Report Identification: 4613 Knoxville St - Houston, TX 77051

I=Inspected NI=Not Inspected NP=Not Present D=Deficient

I NI NP D

Units are not inspected for proper size or efficiency.

A more thorough investigation of the system, including the heat (firebox) exchanger, should be conducted by a licensed HVAC service person every year.

Failure to do so may result in carbon monoxide escaping through cracks in a heat exchanger or flue pipe, resulting in death.

III. HEATING, VENTILATION AND AIR CONDITIONING SYSTEMS

A. Heating Equipment

Type of Systems: Forced air

Energy Sources: Electric

Comments: Unknown manufacturer

Furnace performing as intended at time of inspection.



Client: Michael Jolivet and Dwight Bazile

Report Identification: 4613 Knoxville St - Houston, TX 77051

I=Inspected NI=Not Inspected NP=Not Present D=Deficient

I NI NP D

A. Heating Equipment (continued)



I=Inspected NI=Not Inspected NP=Not Present D=Deficient

I NI NP D

A. Heating Equipment (continued)



Client: Michael Jolivet and Dwight Bazile

Report Identification: 4613 Knoxville St - Houston, TX 77051

I=Inspected NI=Not Inspected NP=Not Present D=Deficient

I NI NP D

A. Heating Equipment (continued)



Year of Manufacture N/A

Client: Michael Jolivet and Dwight Bazile

I=Inspected NI=Not Inspected NP=Not Present D=Deficient

I NI NP D

B. Cooling Equipment

Type of Systems: Central A/C

Comments: Lennox

1. Standing water observed in A/C overflow pan & water dripping from secondary condensation drain.

Moisture in A/C overflow pan often indicates blockage of primary condensation drain line.

Further evaluation and correction recommended by qualified contractor.,

2. Observed no cap flashing (& not weathertight) where the A/C lines enter the structure.

Correction recommended by qualified contractor to avoid moisture / pest intrusion.



Client: Michael Jolivet and Dwight Bazile

I=Inspected NI=Not Inspected NP=Not Present D=Deficient

I NI NP D

B. Cooling Equipment (continued)



Client: Michael Jolivet and Dwight Bazile

Report Identification: 4613 Knoxville St - Houston, TX 77051

I=Inspected NI=Not Inspected NP=Not Present D=Deficient

I NI NP D

B. Cooling Equipment (continued)

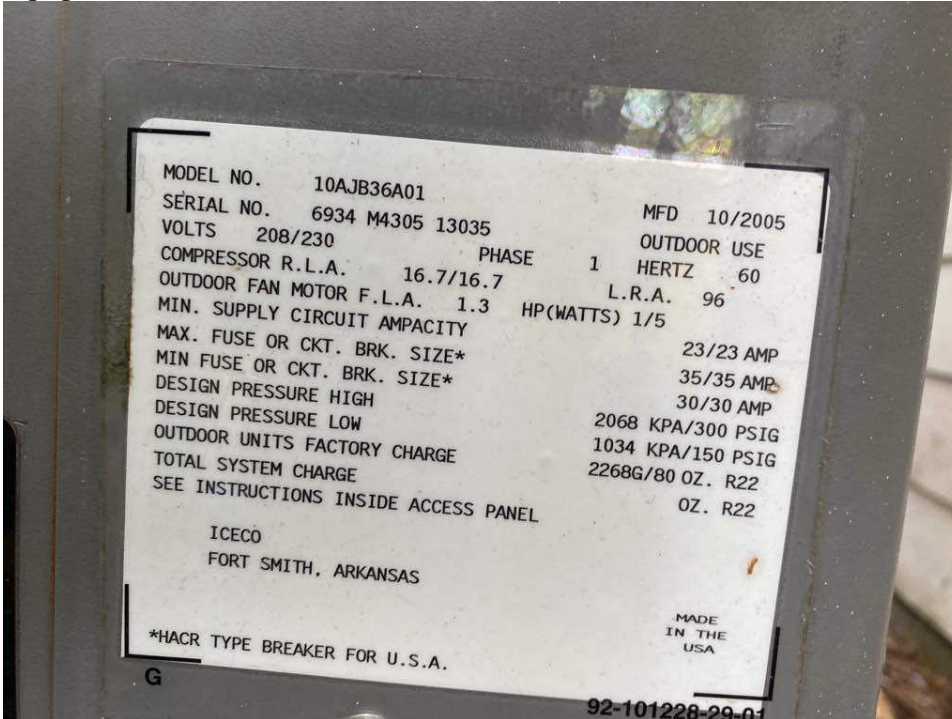

Client: Michael Jolivet and Dwight Bazile

I=Inspected NI=Not Inspected NP=Not Present D=Deficient

I NI NP D

B. Cooling Equipment (continued)

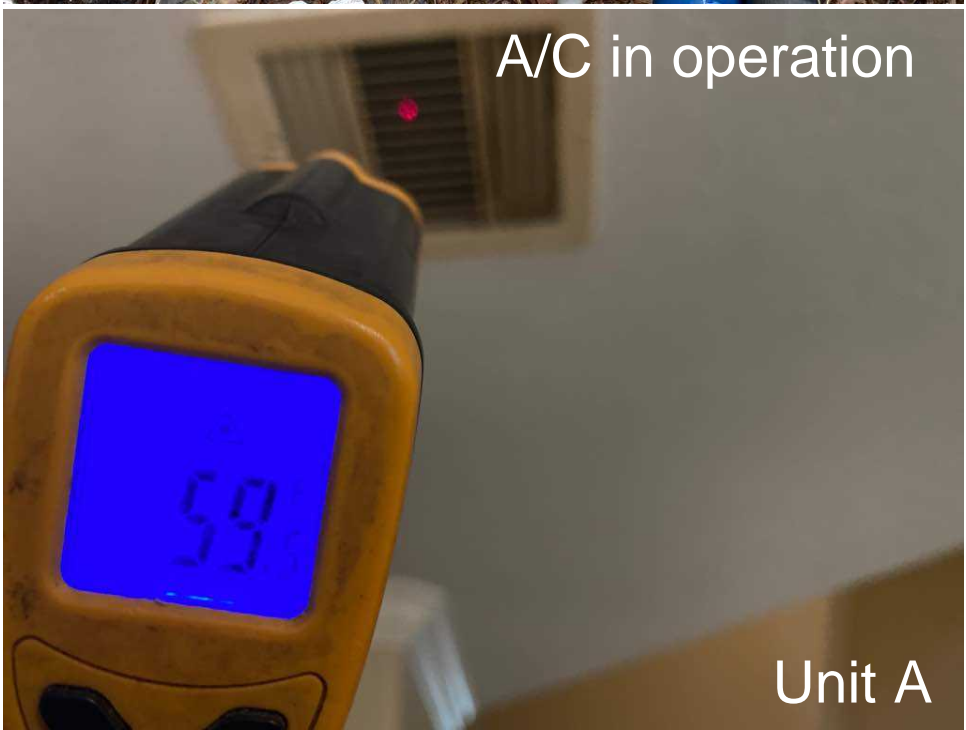

Client: Michael Jolivet and Dwight Bazile

Report Identification: 4613 Knoxville St - Houston, TX 77051

I=Inspected NI=Not Inspected NP=Not Present D=Deficient

I	NI	NP	D
---	----	----	---

Year of Manufacture 2007, 2005

Tonnage of AC System 3 Tons

C. Thermostat

Comments: Programmable,
Thermostat operated as intended at time of inspection

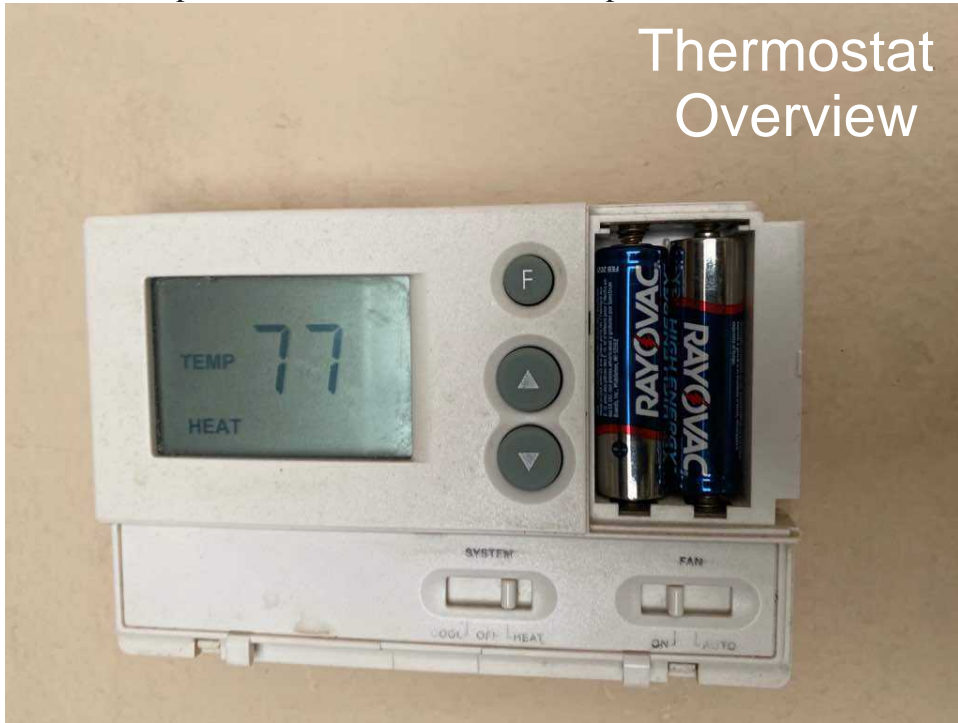

Client: Michael Jolivet and Dwight Bazile

I=Inspected NI=Not Inspected NP=Not Present D=Deficient

I NI NP D

D. Duct Systems, Chases, and Vents

Comments: Insulated flex,

Damage observed at air supply duct in the attic.

Correction recommended by qualified contractor.

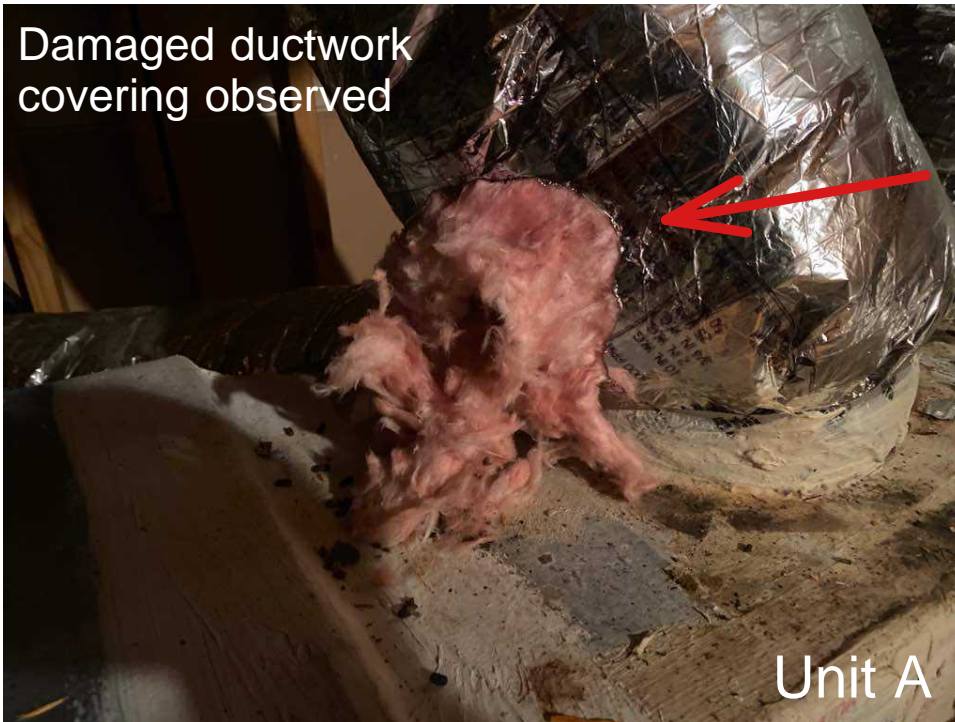

Report Identification: 4613 Knoxville St - Houston, TX 77051

I=Inspected NI=Not Inspected NP=Not Present D=Deficient

I	NI	NP	D
---	----	----	---

E. Air Vents, Grilles, Registers

Comments: Ceiling Air Supply Vent,
Air supply vents appeared to operate as intended at time of inspection.



IV. PLUMBING SYSTEMS

Client: Michael Jolivet and Dwight Bazile



Report Identification: 4613 Knoxville St - Houston, TX 77051

I=Inspected NI=Not Inspected NP=Not Present D=Deficient

I NI NP D

A. Plumbing Supply, Distribution Systems and Fixtures

Location of water meter: The water meter is located at the front curb of home.

Location of main water supply valve: Water meter

Static water pressure reading: 40-80 psi (normal range)

Type of supply piping material:

Comments: Copper

1. Observed non-insulated water pipes in the attic.

All exposed attic water pipes should be insulated for freeze protection.

Further evaluation & correction recommended by qualified contractor.

2. No vacuum breaker on outside hose bib.

Vacuum breaker prevents back siphoning of outside water into indoor plumbing.

Correction recommended by qualified contractor.

3. Pipe penetration(s) not sealed.

Sealing all penetrations helps to prevent moisture and pest intrusion.

Correction recommended by qualified contractor.

Client: Michael Jolivet and Dwight Bazile

I=Inspected NI=Not Inspected NP=Not Present D=Deficient

I NI NP D

A. Plumbing Supply, Distribution Systems and Fixtures (continued)



I=Inspected NI=Not Inspected NP=Not Present D=Deficient

I NI NP D

A. Plumbing Supply, Distribution Systems and Fixtures (continued)



Client: Michael Jolivet and Dwight Bazile

Report Identification: 4613 Knoxville St - Houston, TX 77051

I=Inspected NI=Not Inspected NP=Not Present D=Deficient

I NI NP D

B. Toilets

Comments: Flushing (Two-Piece) Toilet,

Observed toilet loose at floor mounting.

Correction recommended by qualified contractor.



I=Inspected NI=Not Inspected NP=Not Present D=Deficient

I	NI	NP	D
---	----	----	---

C. Sinks

Comments: Built In Sink,

1. Observed loose or damaged kitchen faucet hardware (Unit B).

Correction recommended by qualified contractor.

2. Observed sink leaked into cabinet below (Unit A)

Correction recommended by qualified contractor.



Client: Michael Jolivet and Dwight Bazile

I=Inspected NI=Not Inspected NP=Not Present D=Deficient

I NI NP D

C. Sinks (continued)

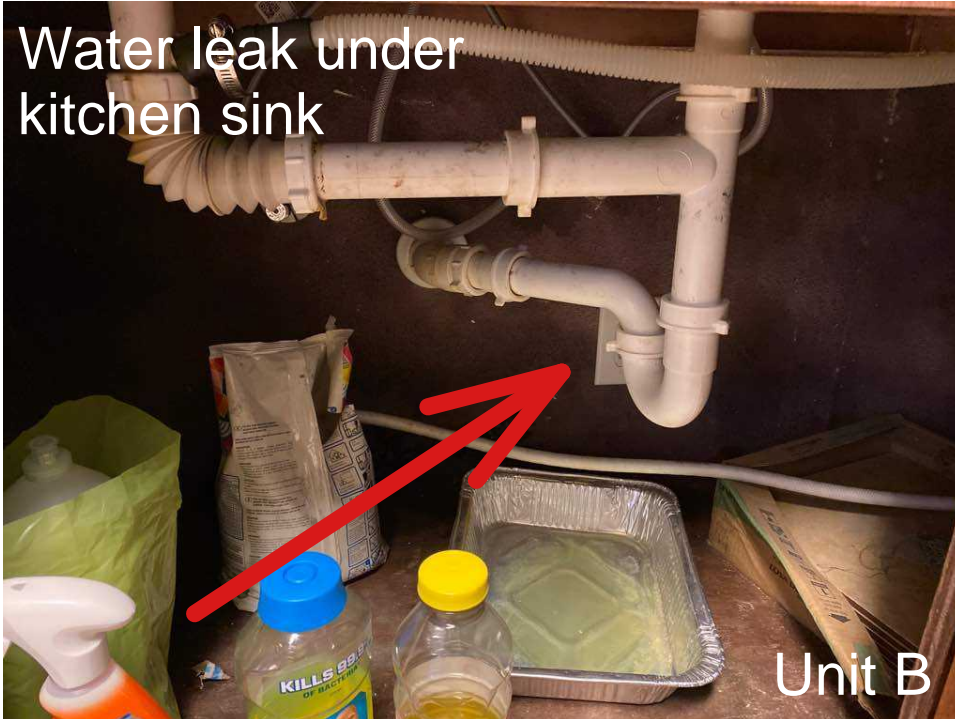

☒ ☐ ☐ ☒

D. Bathtubs & Showers

Comments: Built In bathtub / shower,

Observed showerhead not secured properly (Unit A).

Correction recommended by qualified contractor.

Report Identification: 4613 Knoxville St - Houston, TX 77051

I=Inspected NI=Not Inspected NP=Not Present D=Deficient

I NI NP D

D. Bathtubs & Showers (continued)



E. Drains, Wastes, and Vents

Type of drain piping material: Copper

Comments: Copper

Drains, wastes, and vents were operating as intended at time of inspection.

I=Inspected NI=Not Inspected NP=Not Present D=Deficient

I NI NP D

E. Drains, Wastes, and Vents (continued)

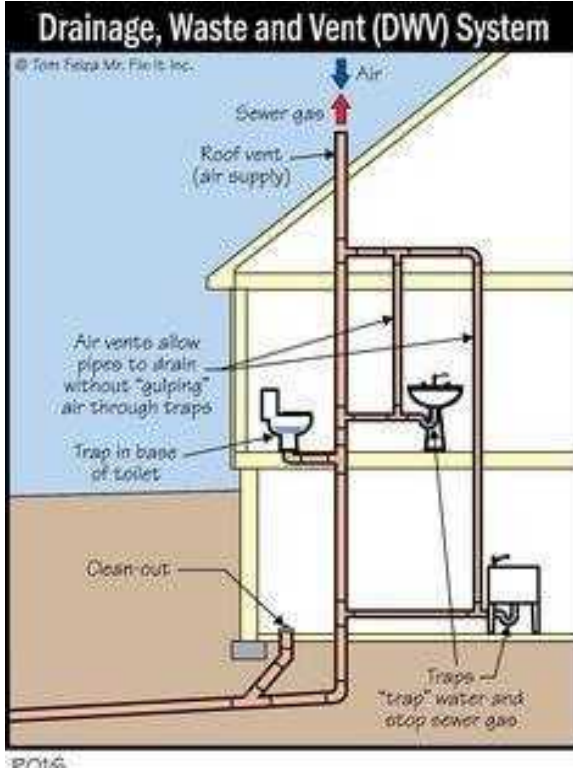

Client: Michael Jolivet and Dwight Bazile

I=Inspected NI=Not Inspected NP=Not Present D=Deficient

I	NI	NP	D
---	----	----	---

C. Water Heating Equipment

Energy Sources: Electric
Capacity: 40 Gallon
Comments: A.O. Smith, A.O. Smith

No TPR (Temperature Pressure Relief) drain pipe observed / installed at time of inspection.

The purpose of the TPR (Temperature Pressure Relief) drain pipe is to discharge water / steam if the water heater were to become overheated / over pressurized.

Correction recommended by qualified contractor.

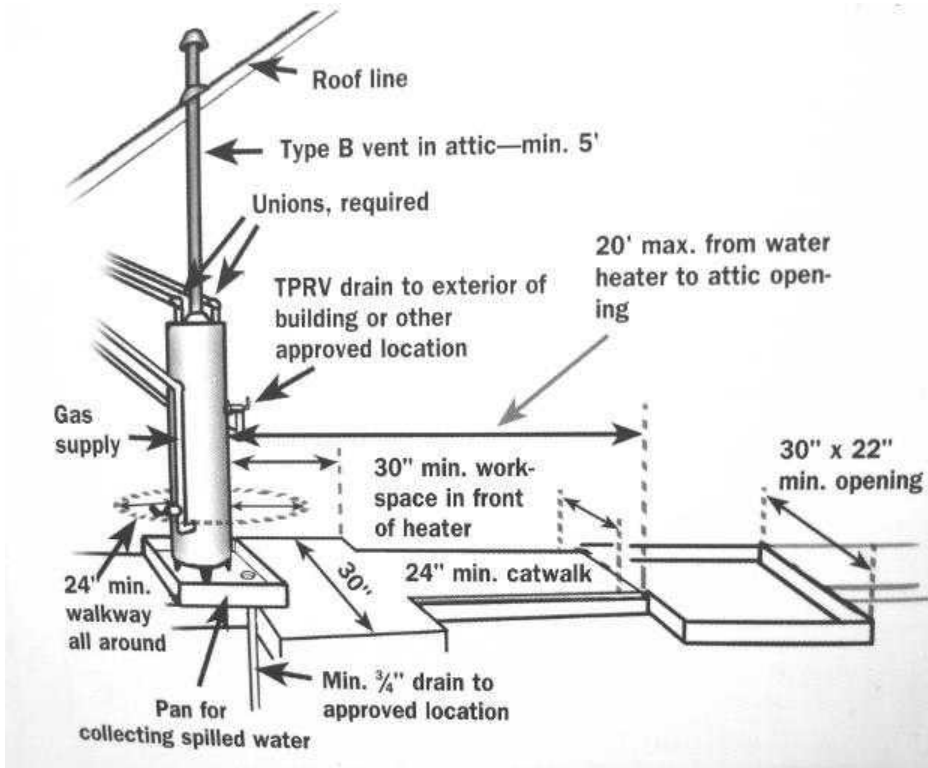

Client: Michael Jolivet and Dwight Bazile

Report Identification: 4613 Knoxville St - Houston, TX 77051

I=Inspected NI=Not Inspected NP=Not Present D=Deficient

I NI NP D

C. Water Heating Equipment (continued)

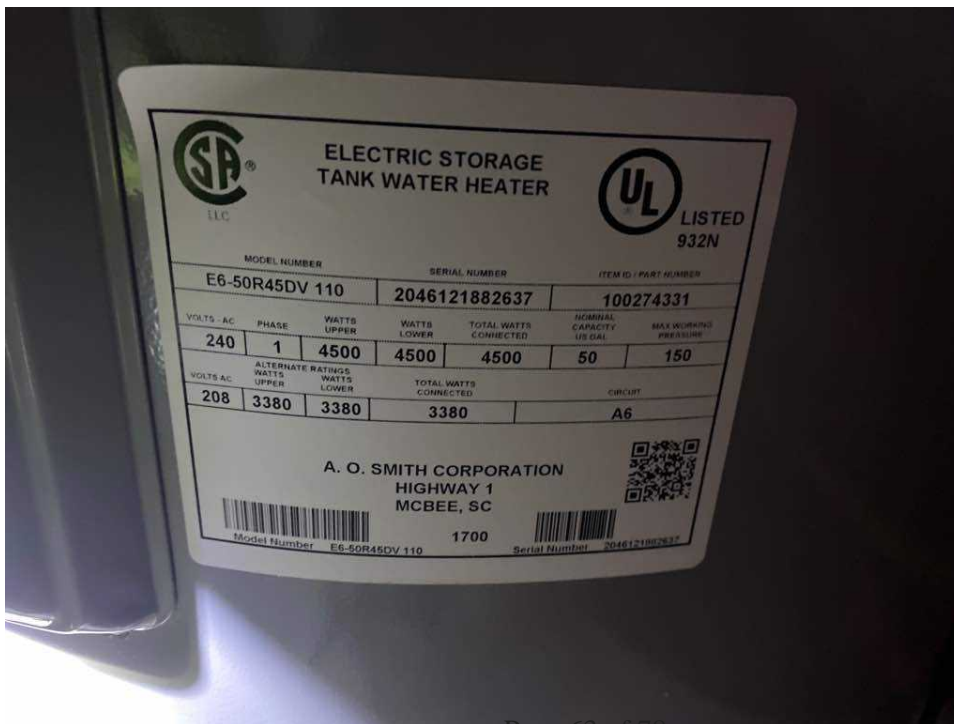
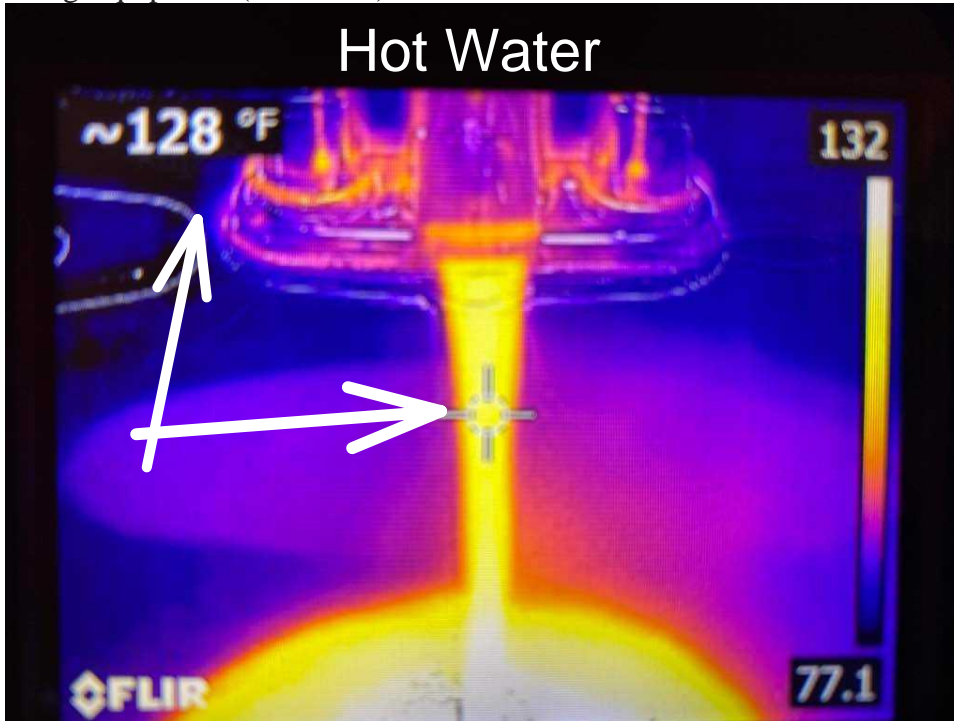

Client: Michael Jolivet and Dwight Bazile

I=Inspected NI=Not Inspected NP=Not Present D=Deficient

I NI NP D

C. Water Heating Equipment (continued)

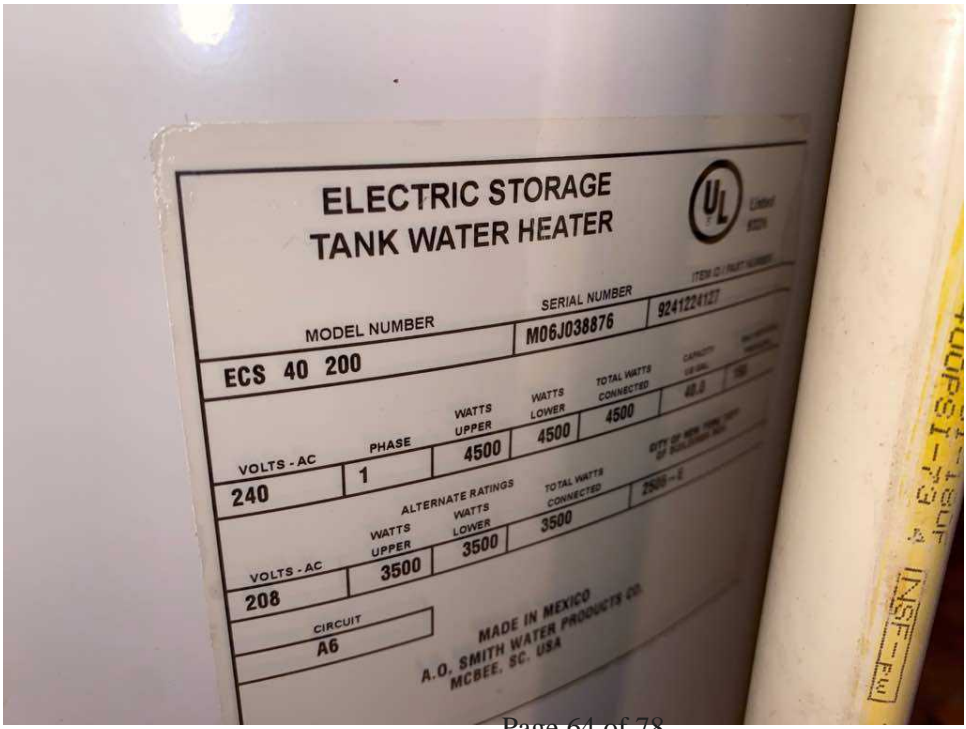

Client: Michael Jolivet and Dwight Bazile

Report Identification: 4613 Knoxville St - Houston, TX 77051

I=Inspected NI=Not Inspected NP=Not Present D=Deficient

I	NI	NP	D
---	----	----	---

C. Water Heating Equipment (continued)



Year of Manufacture 2020

D. Hydro-Massage Therapy Equipment
Comments:

Client: Michael Jolivet and Dwight Bazile

Report Identification: 4613 Knoxville St - Houston, TX 77051

I=Inspected NI=Not Inspected NP=Not Present D=Deficient

I	NI	NP	D
---	----	----	---

E. Gas Distribution Systems and Gas Appliances

Location of gas meter: Exterior surface mount at side of home

Type of gas distribution piping material: Metal

Comments: Gas Meter

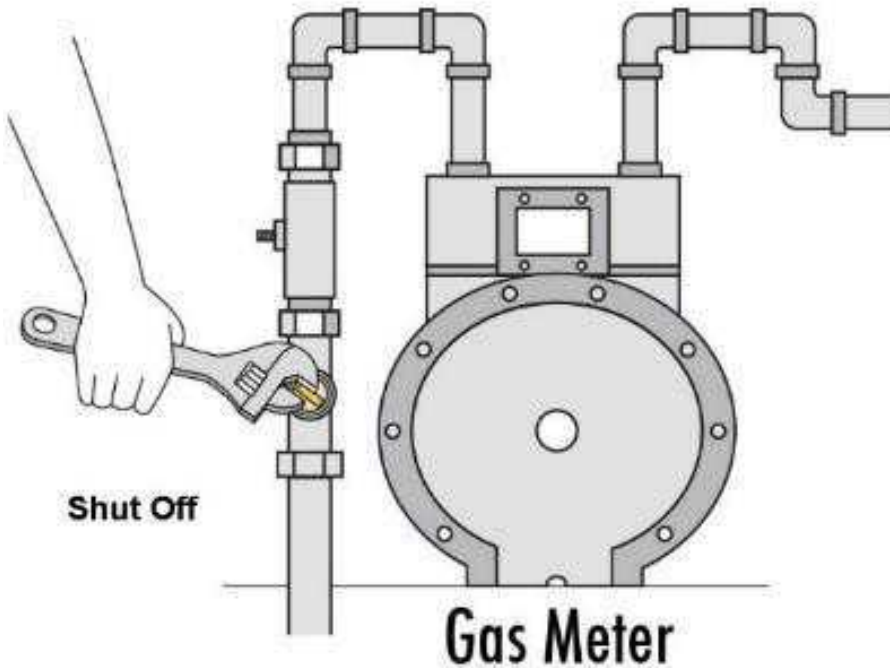

F. Other

Comments:

Report Identification: 4613 Knoxville St - Houston, TX 77051

I=Inspected NI=Not Inspected NP=Not Present D=Deficient

I NI NP D

V. APPLIANCES

A. Dishwashers

Comments: Kenmore,

No items requiring repair were visible at the time of the inspection for the operation of the dishwasher.

The unit was run through a cycle at the time of the inspection, and appeared to be operating properly.



Report Identification: 4613 Knoxville St - Houston, TX 77051

I=Inspected NI=Not Inspected NP=Not Present D=Deficient

I	NI	NP	D
---	----	----	---

B. Food Waste Disposers

Comments: In-Sinkerator,
Food waste disposer was operating as intended at time of inspection.

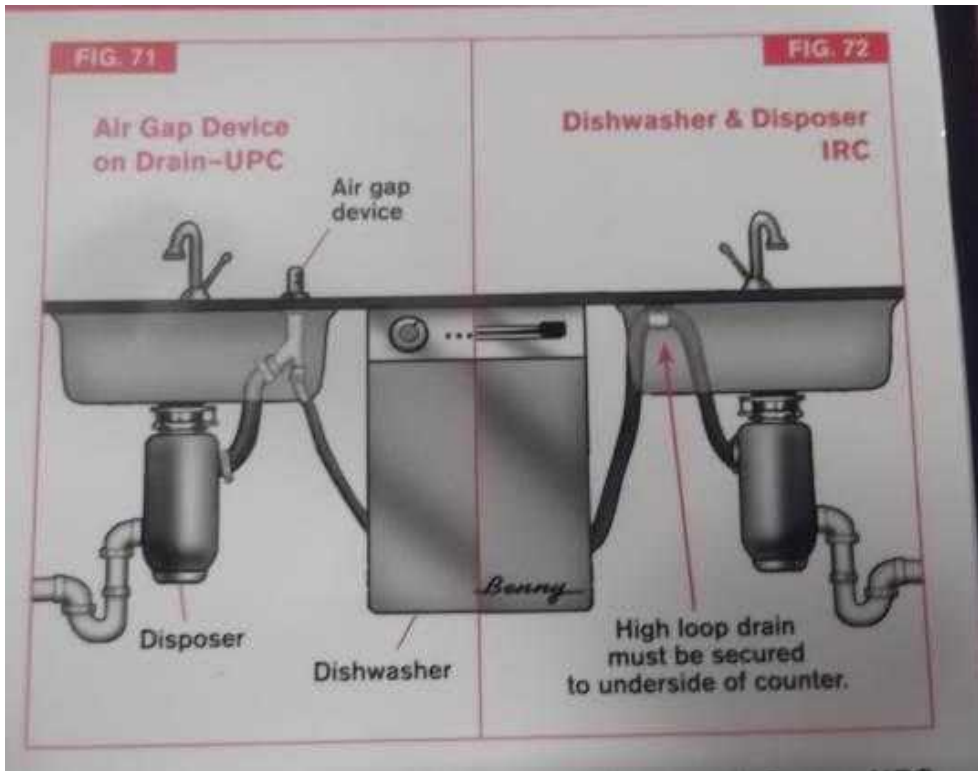

Client: Michael Jolivet and Dwight Bazile

Report Identification: 4613 Knoxville St - Houston, TX 77051

I=Inspected NI=Not Inspected NP=Not Present D=Deficient

I NI NP D

C. Range Hood and Exhaust Systems

Comments: Frigidaire,
Range exhaust vent operated as intended at time of inspection.



Client: Michael Jolivet and Dwight Bazile

I=Inspected NI=Not Inspected NP=Not Present D=Deficient

I NI NP D

D. Ranges, Cooktops, and Ovens

Comments: General Electric,

No anti-tip brackets installed on oven (safety).

Correction recommended by qualified contractor.

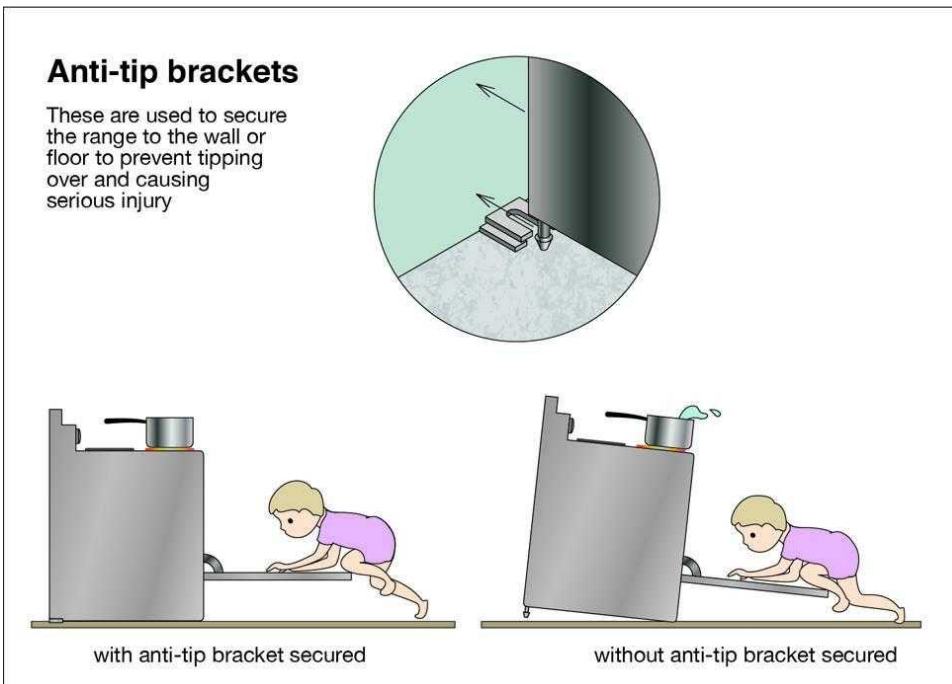

Client: Michael Jolivet and Dwight Bazile

Report Identification: 4613 Knoxville St - Houston, TX 77051

I=Inspected NI=Not Inspected NP=Not Present D=Deficient

I	NI	NP	D
---	----	----	---

D. Ranges, Cooktops, and Ovens (continued)



☒☐☐☒

E. Microwave Ovens

Comments: Frigidaire,

Damaged door hardware observed (Unit B).

Correction recommended by qualified contractor

Client: Michael Jolivet and Dwight Bazile

I=Inspected NI=Not Inspected NP=Not Present D=Deficient

I NI NP D

E. Microwave Ovens (continued)



F. Mechanical Exhaust Vents and Bathroom Heaters

Comments: Broan,
Bathroom exhaust vent operated as intended at time of inspection.

Client: Michael Jolivet and Dwight Bazile



Report Identification: 4613 Knoxville St - Houston, TX 77051

I=Inspected NI=Not Inspected NP=Not Present D=Deficient

I NI NP D

F. Mechanical Exhaust Vents and Bathroom Heaters (continued)

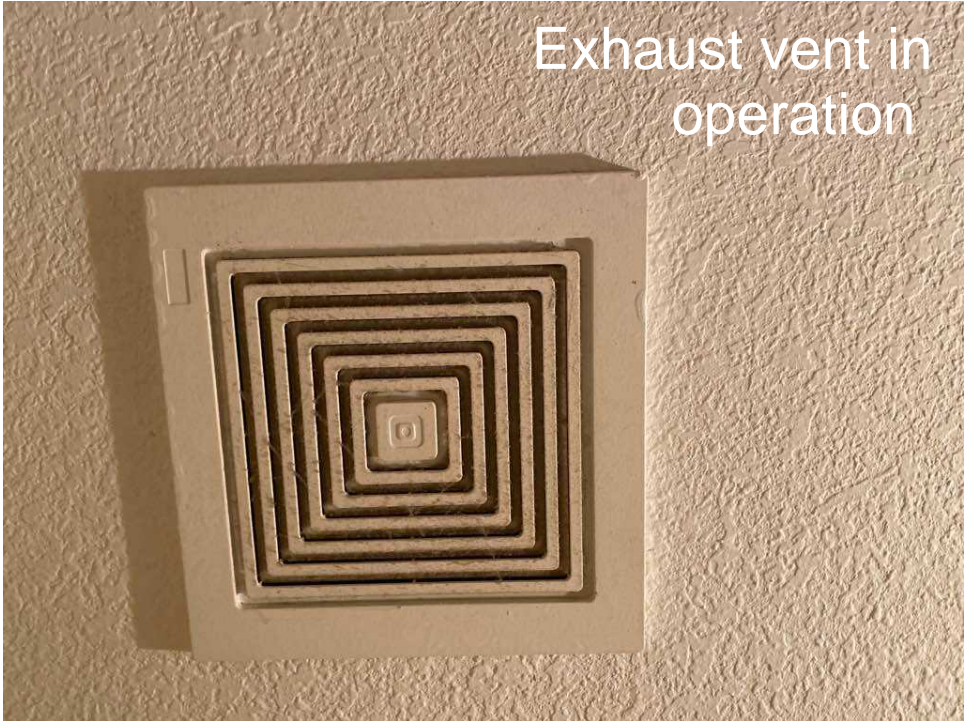

G. Garage Door Operators
Comments:

H. Dryer Exhaust Systems
Comments: Metal flex,
No deficiencies observed in the condition of the dryer vent (at time of the inspection)

Inspector recommends that dryer vent be cleaned at the time of purchase (& annually) to help ensure that safe conditions exist.

Lint accumulation can occur even in approved, properly installed vents.

Lint accumulation can be a potential fire hazard.

All work should be performed by a qualified contractor.

I. Other
Comments:

Client: Michael Jolivet and Dwight Bazile



Report Identification: 4613 Knoxville St - Houston, TX 77051

Summary

I. STRUCTURAL SYSTEMS

B. Grading and Drainage Moderate slope,

Soil / mulch too high at foundation.

Soil (or mulch) too high at foundation can potentially promote pest intrusion.

It is recommended that at least 4 of foundation be visible.

Correction recommended by qualified contractor.

D. Roof Structures and Attics Rafter,

Observed no insulation / weatherstripping at attic access door.

Correction recommended by qualified contractor to minimize opportunity for heating / cooling loss at attic access door. Viewed From: In the attic Approximate Average Depth of Insulation: 7 - 12

E. Walls (Interior and Exterior) Drywall / Fiber Cement,

Damaged wall covering (exterior) observed.

a. Wood rot observed (multiple areas).

Correction recommended to minimize possibility of moisture / pest intrusion.

F. Ceilings Drywall,

Observed moisture stains at ceiling (active leak).

Moisture stains can indicate moisture intrusion and / or structural deficiency.

Further evaluation and correction recommended by qualified contractor.

H. Doors (Interior and Exterior) Wood,

1. Burglar bars (keyed) observed at doors.

Keyed burglar inhibit exit in emergency situations.

Further evaluation and correction recommended by qualified contractor.



Report Identification: 4613 Knoxville St - Houston, TX 77051

Summary (continued)

H. Doors (Interior and Exterior) (continued)

2. Missing doorstop observed.

Correction recommended by qualified contractor to avoid wall damage.

I. Windows Single hung window,

Burglar bars observed at windows.

Keyed burglar inhibit exit in emergency situations.

Further evaluation and correction recommended by qualified contractor.

J. Stairways (Interior and Exterior) Wood stairs with wood handrails,

Stair handrails loose (moves unsteadily from side to side).

Correction recommended by qualified contractor.

M. Fences / Gates Wood Fence,

Observed damaged fence pickets / posts.

Damaged fence pickets / posts can be safety issue.

Recommend further evaluation & correction by qualified contractor.

II. ELECTRICAL SYSTEMS

A. Service Entrance and Panels Copper and Aluminum,

1. No anti-oxidant paste observed at main electrical aluminum cables in panel.

Anti oxidant paste is recommended for aluminum cables because (without the paste) aluminum can overheat & become fire hazard.

Further evaluation & correction recommended by qualified contractor.

2. Main electrical panel not sealed at interface with exterior wall covering (at time of inspection).

Panel/service boxes should be sealed on top and both sides to minimize the possibility of moisture / pest intrusion.

Correction recommended by qualified contractor.

Page 75 of 78



Report Identification: 4613 Knoxville St - Houston, TX 77051

Summary (continued)

A. Service Entrance and Panels (continued)

3. Non covered electrical wiring observed (Unit B).

Correction recommended by qualified contractor

B. Branch Circuits, Connected Devices, and Fixtures Copper,

Electrical covers missing from outlets (multiple).

Correction recommended by qualified contractor. Type of Wiring: Copper

E. Smoke / Carbon Monoxide Detectors Kiddie,

Observed batteries needing replacement in smoke detectors (multiple).

Correction recommended by qualified contractor to ensure proper safety.

III. HEATING, VENTILATION AND AIR CONDITIONING SYSTEMS

B. Cooling Equipment Lennox,

1. Standing water observed in A/C overflow pan & water dripping from secondary condensation drain.

Moisture in A/C overflow pan often indicates blockage of primary condensation drain line.

Further evaluation and correction recommended by qualified contractor.,

2. Observed no cap flashing (& not weathertight) where the A/C lines enter the structure.

Correction recommended by qualified contractor to avoid moisture / pest intrusion. Type of System:

Central A/C

D. Duct Systems, Chases, and Vents Insulated flex,

Damage observed at air supply duct in the attic.

Correction recommended by qualified contractor.

IV. PLUMBING SYSTEMS

A. Plumbing Supply, Distribution Systems and Fixtures Copper,

1. Observed non-insulated water pipes in the attic.



Report Identification: 4613 Knoxville St - Houston, TX 77051

Summary (continued)

A. Plumbing Supply, Distribution Systems and Fixtures (continued)

All exposed attic water pipes should be insulated for freeze protection.

Further evaluation & correction recommended by qualified contractor.

2. No vacuum breaker on outside hose bib.

Vacuum breaker prevents back siphoning of outside water into indoor plumbing.

Correction recommended by qualified contractor.

3. Pipe penetration(s) not sealed.

Sealing all penetrations helps to prevent moisture and pest intrusion.

Correction recommended by qualified contractor. Location of water meter: The water meter is located at the front curb of home. Location of main water supply valve: Water meter Static water pressure reading: 40-80 psi (normal range) Type of supply piping material:

B. Toilets Flushing (Two-Piece) Toilet,

Observed toilet loose at floor mounting.

Correction recommended by qualified contractor.

C. Sinks Built In Sink,

1. Observed loose or damaged kitchen faucet hardware (Unit B).

Correction recommended by qualified contractor.

2. Observed sink leaked into cabinet below (Unit A)

Correction recommended by qualified contractor.

D. Bathtubs & Showers Built In bathtub / shower,

Observed showerhead not secured properly (Unit A).

Correction recommended by qualified contractor.



Report Identification: 4613 Knoxville St - Houston, TX 77051

Summary (continued)

C. Water Heating Equipment A.O. Smith, A.O. Smith,

No TPR (Temperature Pressure Relief) drain pipe observed / installed at time of inspection.

The purpose of the TPR (Temperature Pressure Relief) drain pipe is too discharge water / steam if the water heater were to become overheated / over pressurized.

Correction recommended by qualified contractor. Energy Source: Electric Capacity: 40 Gallon

V. APPLIANCES

D. Ranges, Cooktops, and Ovens General Electric,

No anti-tip brackets installed on oven (safety).

Correction recommended by qualified contractor.

E. Microwave Ovens Frigidaire,

Damaged door hardware observed (Unit B).

Correction recommended by qualified contractor