

Back Side Beam Layout

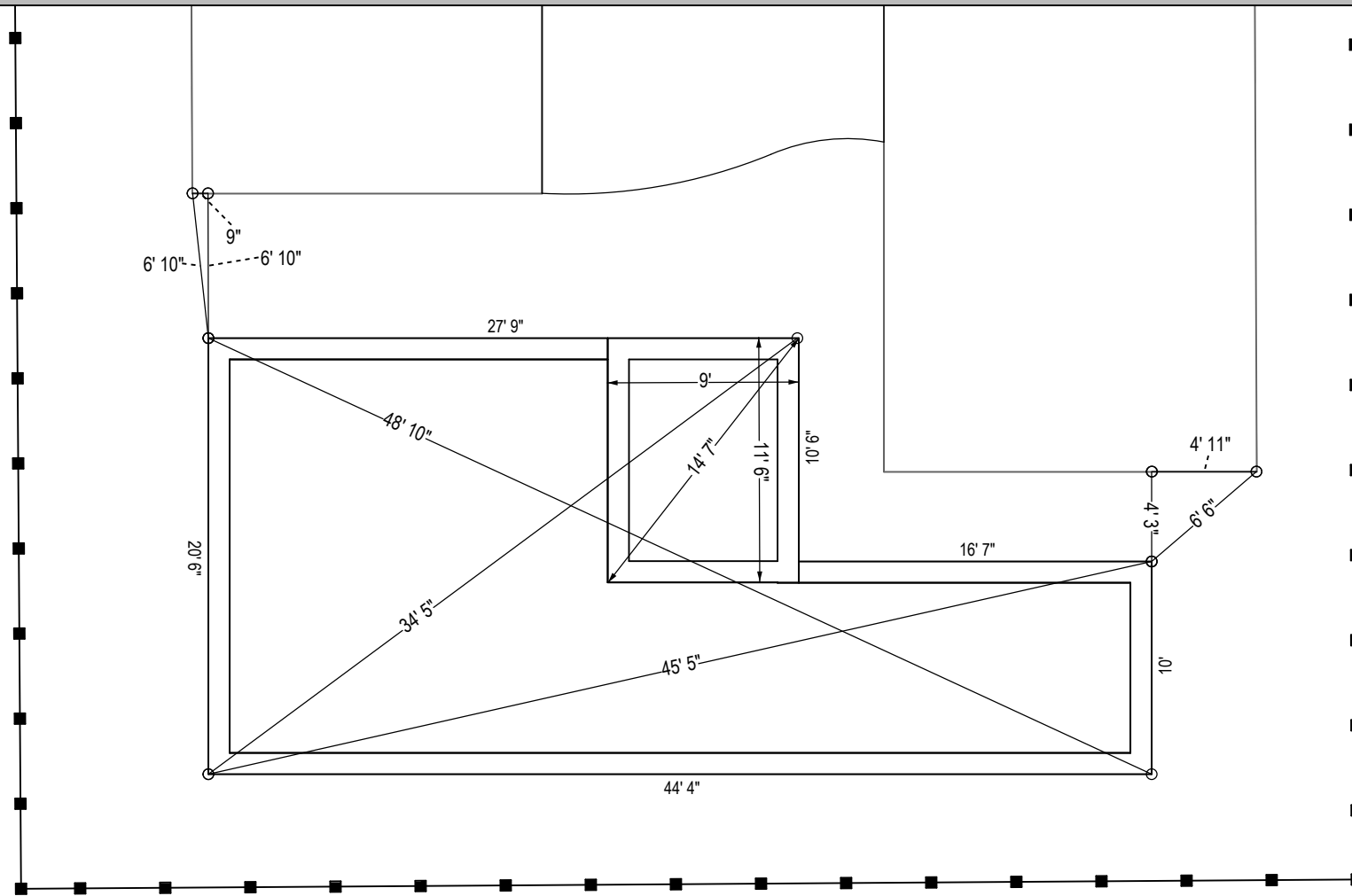

Project Specifications

POOL SPECS			
DBX Job #	N/A	Total Gallons	14,415
Water Length & Width	18.5 x 42	Depths	3.5 x 6
Sqft of Surface Area	504	Total Perimeter	122
Salesman	Chad Britton		
Customer	The Green Family		
Street	1917 Gardenia Dr		
City, State, & Zip	Houston TX 77018		
Customer Phone #	281-948-0513		
Controller & Connection Type			
Main/Spa Pump	Easy Touch		
Spa Booster Pump	Easy Touch - Booster Pump		
Blower	Easy Touch		
Sheers	Easy Touch - Booster Pump		
Cleaner	Easy Touch - Booster Pump		
Pool/Spa Lights	Easy Touch		
Excavator Specs			
Bobcat Size	7'	Demolition in Sqft	0
Grading	No	9" Over Dig Pool	No
Stumps	0	Bell- End Piers	0
Fence Sections	3		
Coping Elevation	3CM Quartz Paver		
Pool Equip	Filter Pump	3 HP Pump	
Booster Pump/s	See Equip Specs Callout On Plan		
Controls Type/s	Pentair EasyTouch 8		
Deck Type & Appurtenances			
Type	521	sqft x Travertine Pavers	
Topping	207	sqft x Travertine Pavers	
Drains	165	Inft x 4in Area Drains/Master Plumber	
Drain Boxes 12"x12"	N/A		
Turndown	N/A		
Footer	N/A		
Turf	N/A		

Depth Profile

