

Structural Options:
1. Roof Pitch: 6:12

Lot Coverage Calculations:
Lot Area: 5326 Sq.Ft.
Slab Area: 2196 Sq.Ft.
Coverage Ratio: 41 %

SOD Calculation:
Front: 141 Sq.Yd.
Side: 61 Sq.Yd.
Rear: 99 Sq.Yd.
Total: 301 Sq.Yd.

Fence Calculation:
Front: 11 Ln.Ft.
Left: 18 Ln.Ft.
Right: 25 Ln.Ft.
Back: 50 Ln.Ft.
Total: 104 Ln.Ft.

Flatwork Areas:
Private Walk (A): 23 Sq.Ft.
Driveway (B): 621 Sq.Ft.
In-Turn (C): 194 Sq.Ft.
Public Walk (D): 0 Sq.Ft.
Conc. Patio (E): 0 Sq.Ft.
AC Pad: 16 Sq.Ft.

Legend:

—x—x—x—	Fence
—	Lot
- - - - -	Building Line
- · - · - · -	Easement
—	Drive/Walk/Patio
▬▬▬▬▬▬▬▬▬▬	Grade Beam
▬▬▬▬▬▬▬▬▬▬	Retaining Wall
▨▨▨▨▨▨▨▨▨▨	Pad Area
▩▩▩▩▩▩▩▩▩▩	Slab/Porch
→	Drainage Direction

General Notes:

- The purpose of this plan is to show the proposed building footprint as defined by the metes and bounds of the recorded plat.
- Dimensions, setbacks, easements, plan selection, and any other information shown here in shall be verified at permitting and prior to construction for accuracy and compliance with all applicable codes and ordinances.
- Builder is solely responsible for ensuring that the footprint is contained within the prepared building pad. The building pad shall be set high enough to allow for adequate drainage.
- All calculations are approximate. They must be verified prior to permitting, purchasing, and/or construction.

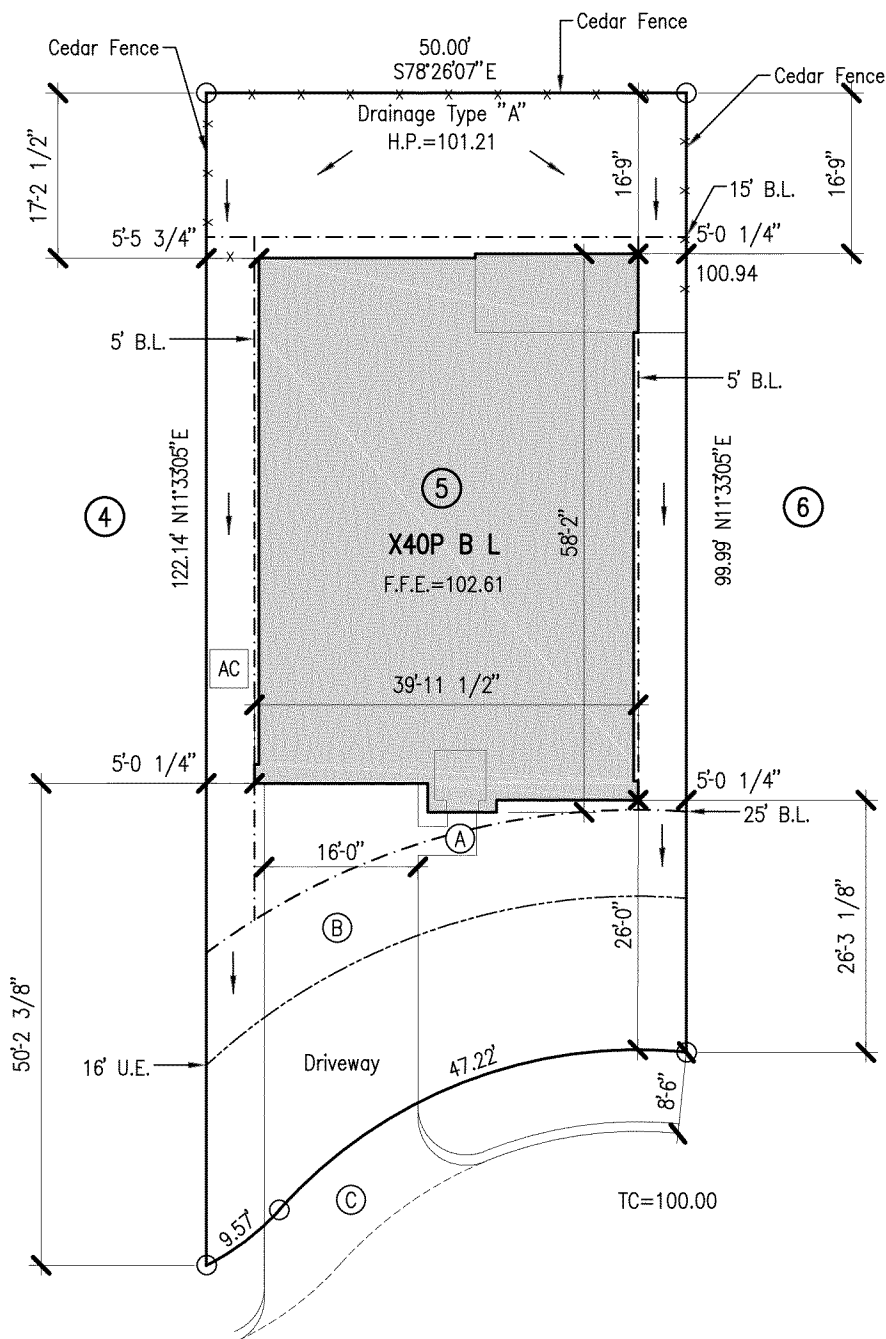

STRAND 2309332R1	PL1	DATE: 7/06/23	BUILDER: Express Homes Houston (North)	VER. 4	PLOT PLAN	7/06/23	10003 Technology Blvd, West Dallas, TX 75220 972-620-8204 Registration No. F-1629	STRAND
		SCALE: 1"=20' DRN: JS	SUBD.: Summerwood Trails Section 2					

The use of these plans and specifications shall be restricted to the site for which they were prepared. Any reproduction or distribution is expressly limited to such use. Any other reproduction, reuse or disclosure by any method, in whole or in part, is prohibited. These drawings and specifications contain proprietary information and title remains in STRAND SYSTEMS ENGINEERING INC.