



8/22/2022 11:28:42 AM

Your Professional Inspection Report Has Been Prepared Exclusively For You.

Danny & Tamra Duarte
5816 Maco St
Galveston, TX 77551
August 22, 2022

Inspected By: Tom Langley TREC #20644
(903)-480-8210

INTEGRITY





PROPERTY INSPECTION REPORT FORM

Danny & Tamra Duarte

Name of Client

08/22/2022

Date of Inspection

5816 Maco St, Galveston, TX 77551

Address of Inspected Property

Tom Langley

Name of Inspector

TREC #20644

TREC License #

Name of Sponsor (if applicable)

TREC License #

PURPOSE OF INSPECTION

A real estate inspection is a visual survey of a structure and a basic performance evaluation of the systems and components of a building. It provides information regarding the general condition of a residence at the time the inspection was conducted. *It is important* that you carefully read ALL of this information. Ask the inspector to clarify any items or comments that are unclear.

RESPONSIBILITY OF THE INSPECTOR

This inspection is governed by the Texas Real Estate Commission (TREC) Standards of Practice (SOPs), which dictates the minimum requirements for a real estate inspection.

The inspector IS required to:

- use this Property Inspection Report form for the inspection;
- inspect only those components and conditions that are present, visible, and accessible at the time of the inspection;
- indicate whether each item was inspected, not inspected, or not present;
- indicate an item as Deficient (D) if a condition exists that adversely and materially affects the performance of a system or component **OR** constitutes a hazard to life, limb or property as specified by the SOPs; and
- explain the inspector's findings in the corresponding section in the body of the report form.

The inspector IS NOT required to:

- identify all potential hazards;
- turn on decommissioned equipment, systems, utilities, or apply an open flame or light a pilot to operate any appliance;
- climb over obstacles, move furnishings or stored items;
- prioritize or emphasize the importance of one deficiency over another;
- provide follow-up services to verify that proper repairs have been made; or
- inspect system or component listed under the optional section of the SOPs (22 TAC 535.233).

RESPONSIBILITY OF THE CLIENT

While items identified as Deficient (D) in an inspection report DO NOT obligate any party to make repairs or take other actions, in the event that any further evaluations are needed, it is the responsibility of the client to obtain further evaluations and/or cost estimates from qualified service professionals regarding any items reported as Deficient (D). It is recommended that any further evaluations and/or cost estimates take place prior to the expiration of any contractual time limitations, such as option periods.

Please Note: Evaluations performed by service professionals in response to items reported as Deficient (D) on the report may lead to the discovery of additional deficiencies that were not present, visible, or accessible at the time of the inspection. Any repairs made after the date of the inspection may render information contained in this report obsolete or invalid.

REPORT LIMITATIONS

This report is provided for the benefit of the named client and is based on observations made by the named inspector on the date the inspection was performed (indicated above).

ONLY those items specifically noted as being inspected on the report were inspected.

This inspection IS NOT:

- a technically exhaustive inspection of the structure, its systems, or its components and may not reveal all deficiencies;
- an inspection to verify compliance with any building codes;
- an inspection to verify compliance with manufacturer's installation instructions for any system or component and DOES NOT imply insurability or warrantability of the structure or its components.

NOTICE CONCERNING HAZARDOUS CONDITIONS, DEFICIENCIES, AND CONTRACTUAL AGREEMENTS

Conditions may be present in your home that did not violate building codes or common practices in effect when the home was constructed but are considered hazardous by today's standards. Such conditions that were part of the home prior to the adoption of any current codes prohibiting them may not be required to be updated to meet current code requirements. However, if it can be reasonably determined that they are present at the time of the inspection, the potential for injury or property loss from these conditions is significant enough to require inspectors to report them as Deficient (D). Examples of such hazardous conditions include:

- malfunctioning, improperly installed or missing ground fault circuit protection (GFCI) devices and arc-fault devices;
- ordinary glass in locations where modern construction techniques call for safety glass;
- malfunctioning or lack of fire safety features such as, smoke alarms, fire-rated doors in certain locations, and functional emergency escape and rescue openings in bedrooms;
- malfunctioning carbon monoxide alarms;
- excessive spacing between balusters on stairways and porches;
- improperly installed appliances;
- improperly installed or defective safety devices;
- lack of electrical bonding and grounding; and
- lack of bonding on gas piping, including corrugated stainless steel tubing (CSST).

Please Note: items identified as Deficient (D) in an inspection report DO NOT obligate any party to make repairs or take other actions. The decision to correct a hazard or any deficiency identified in an inspection report is left up to the parties to the contract for the sale or purchase of the home.

This property inspection report may include an inspection agreement (contract), addenda, and other information related to property conditions.

INFORMATION INCLUDED UNDER "ADDITIONAL INFORMATION PROVIDED BY INSPECTOR", OR PROVIDED AS AN ATTACHMENT WITH THE STANDARD FORM, IS NOT REQUIRED BY THE COMMISSION AND MAY CONTAIN CONTRACTUAL TERMS BETWEEN THE INSPECTOR AND YOU, AS THE CLIENT. THE COMMISSION DOES NOT REGULATE CONTRACTUAL TERMS BETWEEN PARTIES. IF YOU DO NOT UNDERSTAND THE EFFECT OF ANY CONTRACTUAL TERM CONTAINED IN THIS SECTION OR ANY ATTACHMENTS, CONSULT AN ATTORNEY.

ADDITIONAL INFORMATION PROVIDED BY INSPECTOR

Inspection Time Started: **9 am**

Weather Conditions Inspection: **Mostly Cloudy**

Outside temperature inspection: **90+ Degrees**

Time Finished: **12:30 pm** Building Orientation **South**

Inspection Provided by this Inspector: Home Inspection, Wood Destroying Insect Inspection

Property was: **Occupied** at the time of Inspection:

(When a property is Occupied during an Inspection there may be various areas where damages or deficiencies may be blocked from the Inspectors view. The inspector will do everything he can to observe and report these deficiencies. However there may be areas he cannot observe.)

Parties that were present during the inspection: **No other parties present during inspection.**

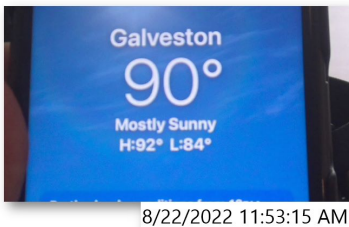

THIS REPORT IS PAID AND PREPARED FOR THE PERSONAL, PRIVATE AND EXCLUSIVE USE OF Danny & Tamra Duarte. THIS IS A COPYRIGHTED REPORT AND IS NOT VALID WITHOUT THE SIGNED INSPECTION AGREEMENT ATTACHED. THIS REPORT IS NOT TRANSFERABLE FROM THE CLIENT NAMED ABOVE.

This report contains representative pictures of certain deficiencies identified during the inspection. Additional photos, if any, can be viewed at the end of this report located in the PHOTO SUMMARY section,

Whenever a defect and/or deficiency of any kind is noted in a system and/or any part and/or item of this structure, we recommend that a qualified, licensed and/or certified specialist and/or technician to inspect, repair and/or service the entire system and/or part. Sometimes noted defects and/or deficiencies are symptoms of other and sometimes more serious conditions and/or defects.

It is also recommended that the buyer walks through the property the day before closing to assure conditions have not changed since inspection.

SCOPE OF INSPECTION

These standards of practice define the minimum levels of inspection required for substantially completed residential improvements to real property up to four dwelling units. A real estate inspection is a non-technically exhaustive, limited visual survey and basic performance evaluation of the systems and components of a building using normal controls and does not require the use of specialized equipment or procedures. The purpose of the inspection is to provide the client with information regarding the general condition of the residence at the time of inspection. The inspector may provide a higher level of inspection performance than required by these standards of practice and may inspect components and systems in addition to those described by the standards of practice.

GENERAL LIMITATIONS

The inspector is **not required to:**

(A) inspect:

- (i) items other than those listed within these standards of practice;
- (ii) elevators;
- (iii) detached buildings, decks, docks, fences, or waterfront structures or equipment;
- (iv) **anything buried, hidden, latent, or concealed;**
- (v) sub-surface drainage systems;
- (vi) automated or programmable control systems, automatic shut-off, photoelectric sensors, timers, clocks, metering devices, signal lights, lightning arrestor system, remote controls, security or data distribution systems, solar panels or smart home automation components; or
- (vii) concrete flatwork such as; driveways, sidewalks, walkways, paving stones or patios;

(B) report:

- (i) past repairs that appear to be effective and workmanlike except as specifically required by these standards;
- (ii) cosmetic or aesthetic conditions; or
- (iii) wear and tear from ordinary use;

(C) determine:

- (i) insurability, warrant ability, suitability, adequacy, compatibility, capacity, reliability, marketability, operating costs, recalls, counterfeit products, product lawsuits, life expectancy, age, energy efficiency, vapor barriers, thermostatic performance, compliance with any code, listing, testing or protocol authority, utility sources, or manufacturer or regulatory requirements except as specifically required by these standards;
- (ii) the presence or absence of pests, termites, or other wood-destroying insects or organisms;
- (iii) the presence, absence, or risk of asbestos, lead-based paint, mold, mildew, corrosive or contaminated drywall "Chinese Drywall" or any other environmental hazard, environmental pathogen, carcinogen, toxin, mycotoxins, pollutant, fungal presence or activity, or poison;

- (iv) types of wood or preservative treatment and fastener compatibility; or
- (v) the cause or source of a conditions;
- (D) anticipate future events or conditions, including but not limited to:
 - (i) decay, deterioration, or damage that may occur after the inspection;
 - (ii) deficiencies from abuse, misuse or lack of use;
 - (iii) changes in performance of any component or system due to changes in use or occupancy;
 - (iv) the consequences of the inspection or its effects on current or future buyers and sellers;
 - (v) common household accidents, personal injury, or death;
 - (vi) the presence of water penetrations; or
 - (vii) future performance of any item;
- (E) operate shut-off, safety, stop, pressure or pressure-regulating valves or items requiring the use of codes, keys, combinations, or similar devices;
- (F) designate conditions as safe;
- (G) recommend or provide engineering, architectural, appraisal, mitigation, physical surveying, realty, or other specialist services;
- (H) review historical records, installation instructions, repair plans, cost estimates, disclosure documents, or other reports;
- (I) verify sizing, efficiency, or adequacy of the ground surface drainage system;
- (J) verify sizing, efficiency, or adequacy of the gutter and downspout system;
- (K) operate recirculation or sump pumps;
- (L) remedy conditions preventing inspection of any item;
- (M) apply open flame or light a pilot to operate any appliance;
- (N) turn on decommissioned equipment, systems or utility services; or
- (O) provide repair cost estimates, recommendations, or re-inspection services.

The Client, by accepting this Property Inspection Report or relying upon it in any way, expressly agrees to the SCOPE OF INSPECTION, GENERAL LIMITATIONS and INSPECTION AGREEMENT included in this inspection report.

This inspection report is made for the sole purpose of assisting the purchaser to determine his and/or her own opinion of feasibility of purchasing the inspected property and does not warrant or guarantee all defects to be found. If you have any questions or are unclear regarding our findings, **please call our office prior** to the expiration of any time limitations such as option periods.

This report contains technical information. If you were not present during this inspection, **please call the office** to arrange for a consultation with your inspector. If you choose not to consult with the inspector, this inspection company cannot be held liable for your understanding or misunderstanding of the reports content.

This report is not intended to be used for determining insurability or warrant ability of the structure and may not conform to the Texas Department of Insurance guidelines for property insurability. This report is not to be used by or for any property and/or home warranty company.

The digital pictures in this report are a sample of the damages in place and should not be considered to show all of the damages and/or deficiencies found. There will be some damage and/or deficiencies not represented with digital imaging. When one or two like deficiencies are found they will be listed, when three or more deficiencies are found the term various or multiple will be used. This eliminates the exhaustive reporting of like defects.

I=Inspected

NI=Not Inspected

NP=Not Present

D=Deficient

I NI NP D

I. STRUCTURAL SYSTEMS

A. Foundations

Type of Foundation(s): Pier & Beam

Comments:

Crawl Space Viewed From: Crawled Structure

Property was occupied at the time of inspection. There are areas of the structure that may have been blocked from the view of the inspector. Once the furniture and other objects are removed certain signs may be revealed.. However the inspector inspected the structure as thoroughly as possible to provide you the best information regarding this property.

On 08/22/2022 at 9:00 am Inspector Tom Langley's opinion was that the **Foundation** appeared to be in **fair condition** . At this time, I **did observe** visible evidence that I would consider as being indications of movement and/or settlement. The area inspected were, but may not be limited to the accessible **Walls, Ceilings , Floors, Doors, Windows** which indicated **signs** of movement and/or settlement. As well as the attic space which showed not determined of visible indications of movement and/or settlement.

These opinions are based solely on the observations of the inspector which were made without sophisticated testing procedures, specialized tools and/or equipment. Therefore the opinions expressed are one's of apparent conditions and not absolute fact and are only good on 08/22/2022 .

The crawl space indicated **signs of** movement and/or settlement.

Due to the nature of pier & beam construction and the crawl space, the entire sub floor and its components have not been completely visually inspected. There are areas that were not visible or could not be seen or was obstructed in some way. Every effort has been made to inspect as much of the sub floor as thoroughly as possible, however, the possibility exists that there is moist, soft or rotted wood on the sub-floor or it's components that has not been detected or located.

The items listed below are the Inspectors observations of deficiencies and/or exceptions if any associated with the **foundation** that were noted on this structure at the time of the Inspection:

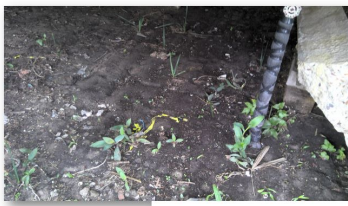

D - A moisture barrier should be installed on the crawl space floor.

I=Inspected

NI=Not Inspected

NP=Not Present

D=Deficient

I	NI	NP	D
---	----	----	---



8/22/2022 9:37:03 AM



8/22/2022 9:37:26 AM



8/22/2022 9:50:44 AM

D - Evidence of Previous and damage of wood destroying insects (subterranean termites ext.) was detected in various areas of the crawlspace on the underside of the structure at the time of inspection. Full evaluation of the amount of damage caused by the insects cannot be detected within the walls, voids, or other hidden areas without defacing the property and cannot be addressed in this report. With the detection of active and/or previous activity of a wood destroying insect, it should be assumed that some degree of damage is present. I recommend that a more evasive inspection be conducted by a licensed pest control company prior to closing. The author of this report is also licensed by the SPCB #12100.



8/22/2022 9:40:18 AM

D - Termite shield should be added to the top of the piers. Recommend repairs be undertaken.

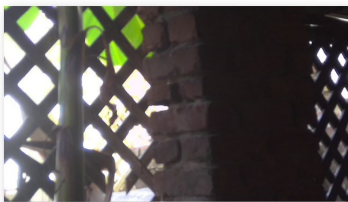

8/22/2022 9:38:45 AM

D - The brick piers need to be re-pointed. Recommend repairs be undertaken.



8/22/2022 9:50:39 AM



8/22/2022 9:54:17 AM



8/22/2022 9:53:38 AM

D - Evidence of moisture damage was noted at but may not be limited to side entry. Water damaged materials are considered a conducive condition for water penetration and insect infestation. Whenever water damaged materials are noted in this report, we recommend consulting a qualified specialist so that a corrective course of action can be evaluated.

I=Inspected

NI=Not Inspected

NP=Not Present

D=Deficient

I NI NP D

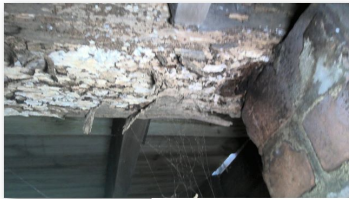

8/22/2022 9:53:35 AM



8/22/2022 9:56:55 AM

D - Beams in multiple areas of the house are damaged. Recommend a foundation company further evaluate and repair as needed.



8/22/2022 9:58:10 AM



8/22/2022 10:02:56 AM

D - There is not enough piers and beams supporting the home. There should be piers every 6 feet no further than 8 feet apart. Recommend a foundation company further evaluate and repair as needed.



8/22/2022 10:06:48 AM

D - Crawlspace has wood to ground contact through out the crawlspace. Wood to ground contact allows wood destroying insects (termites) to enter the home. Homeowner needs to remove wood to ground contact and have annual inspections of these areas.

B. Grading and Drainage

Comments:

In this Inspectors opinion the **Grading and Drainage** appeared to be in **fair condition**

The items listed below are the Inspectors observations of deficiencies and/or exceptions if any associated with the **grading and drainage** that were noted on this structure at the Time of the Inspection:

I=Inspected

NI=Not Inspected

NP=Not Present

D=Deficient

I	NI	NP	D
---	----	----	---

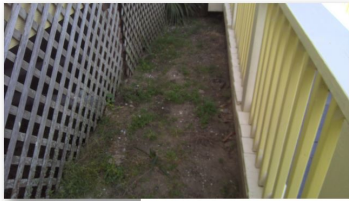

8/22/2022 11:25:48 AM

D - Poor, flat or negative site drainage was observed around the structure . Proper drainage is needed to help prevent water from standing or ponding next to the perimeter beam. Corrective measures may be needed if water stands within 10 feet of the perimeter beam for more than 24 hours.



8/22/2022 11:26:59 AM



8/22/2022 11:28:14 AM



8/22/2022 11:28:31 AM

D - Structure has heavy foliage. Recommend trimming foliage away from structure to reduce the possibility of insects' invasion. (I.e. Carpenter ants).

The proper care and maintenance of the grading is important to the foundation. Improper care for trees, large shrubs and bushes around foundation may cause foundational issues. It is generally recommended that you water outside the current root area to assist roots in growing outside and away from the foundation area. Watering the foundation is also recommended. A soaker hose position 6 to 12 inches away and 6 to 12 inches deep around the foundation, will assist in keeping the soil stable and will assist in providing proper maintenance for the foundation. Consulting a qualified foundation, soil and/or landscaping specialist to inspect the structure would be beneficial in developing a care and maintenance plan for your foundation.

Gutters and downspout's:

In this Inspectors opinion the **Gutter & Downspout System** appeared to be in **Not Installed**

-
-
-
-

C. Roof Covering Materials

Type(s) of Roof Covering: Asphalt Shingles, Rolled Roofing type roof

Viewed From: Walked on roof

Comments:

Roof Cover Material:

At the time of the inspection, the inspectors opinion of the **Roof Covering** is as follows. The roof covering was estimated to be in the **Middle Third** of its life and it appeared to be in **acceptable condition**. The roof decking appeared to be **OSB type decking** and it appeared to be in **acceptable condition**. The roof fasteners appearing to be **fastened properly**.

At the time of the inspection the inspector **did not** observe signs of water penetration on the roof.

I=Inspected

NI=Not Inspected

NP=Not Present

D=Deficient

I NI NP D

At the time of the inspection the inspector **did not** observe any repairs noted on the roof

The items listed below are the Inspectors observations of deficiencies and/or exceptions if any associated with the **Roofing Material** that were noted on this structure at the time of the Inspection:

The performance of this roof is subjective and it is sometimes difficult for two individuals to agree on the life of a roof. Consulting a qualified roofing specialist may assist you to better understand the roof conditions. Asking your roofing specialist to create a roof maintenance schedule for your roof will assist you in minimizing your overall expense .

D. Roof Structures and Attics

Viewed From: Attic Decked Space Only

Approximate Average Depth of Insulation: Unable to determine

Comments:

Description of Roof Structure: Unable to Determine

Roof & Attic Structure:

At the time of the Inspection it was the Inspectors opinion that your **Roofing and Attic structure** appeared to be in **fair condition**

Areas of the attic structure that are blocked from the view of the inspector due to loose filled and batt and blanket insulation, spray foam insulation, wood decking, wood walkways, ect. could not be fully inspected. However the inspector made every effort to inspect the attic structure thoroughly to provide you the best information possible.

At the time of the inspection the inspector **did not** observe signs of water penetration in the roof structure and attic..

The items listed below are the Inspectors observations of deficiencies and/or exceptions if any associated with the **Roof Structure and Attics** that were noted on this structure at the time of the Inspection:

D - The attic space was not accessible at the time of inspection. It is recommended access be provided for proper inspection.

Attic Insulation & Venting

The **Ventilation** for the Roof Structure and Attic was being provided by **No ventilation observed** and appeared to be in **poor condition**. The **Insulation** type is **Unable To Determine** and appeared to be in **Not Determined condition**.

The items listed below are the Inspectors observations of deficiencies and/or exceptions if any associated with the **attics insulation & venting** that were noted on this structure at the time of the Inspection:

D - The level of ventilation should be improved. It is generally recommended that one (1) square foot of free vent area be provided for every one hundred and fifty (150) square feet of ceiling area. Proper ventilation will help to keep the house cooler during warm weather and extend the life of roofing materials. In colder climates, it will help reduce the potential for ice dams on the roof and condensation within the attic.

I=Inspected NI=Not Inspected NP=Not Present D=Deficient

I	NI	NP	D
---	----	----	---

E. Walls (Interior and Exterior)

Comments:

Interior

At the time of the inspection the Inspectors opinion was that the **Interior walls** were a **Drywall type** and appeared to be in **fair condition**

The items listed below are the Inspectors observations of deficiencies and/or exceptions if any associated with the **Interior Walls** that were noted on this structure at the Time of the Inspection:

NI - The inside of the walls thru out the structure could not be inspected due to no access. What is behind sheet rock and other wall cladding can not be seen by the inspector. The inspector can not remove or cause damage to anything at or on the structure. This is a visual inspection of what is acquiring on the day of the inspection.



D - Common hairline wall cracks were noted in the interior wallboard. Cracks near the interior windows and doors are usually indications that there is some degree of movement occurring in the structure. (In any structure some degree of movement is normal and should not be of concern) the severity of the cracks can be an indication of the amount of movement in a structure.

Exterior

At the time of the inspection the Inspectors opinion was that the **Exterior walls** were a **wood type, fiber cement board type** and appeared to be in **fair condition**

The items listed below are the Inspectors observations of deficiencies and/or exceptions if any associated with the **Exterior Walls** that were noted on this structure at the Time of the Inspection:

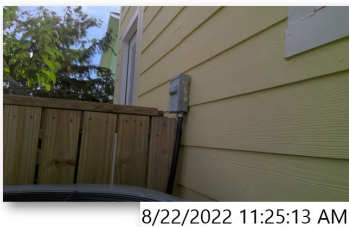

D - There are areas on the exterior wall that are in need of caulking. Any area where moisture can penetrate between the exterior and interior wall should be kept water tight.

I=Inspected NI=Not Inspected NP=Not Present D=Deficient

I	NI	NP	D
---	----	----	---



D - Exterior paint / stain are peeling or are showing signs of wear in several areas Exposed or weathered wood is considered a condition conducive for wood decay and water penetration. The T.R.E.C. Limitations states the inspector is not required to determining the condition of paints, stains, or other surface coatings.



D - Soft, damaged or decayed cladding was noted on the exterior trim and siding Recommend replacing all water damaged wood.

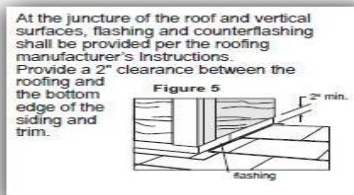

D-The sidewall veneer is in contact with the roofing material. Under current building standards, there should be at least 2-inch of clearance between the roofing material and the sidewall veneer. This will help to eliminate the rotting of the wood siding used on the wall from storm water and moisture exposure.

 F. Ceilings and Floors
Comments:

Ceilings:

In the Inspectors opinion the **Ceilings** appeared to be in **acceptable condition** condition on the Day of this Inspection.

Floors:

In the Inspectors opinion the **Interior floors** appeared to be in **fair condition** condition on the Day of this Inspection.

I=Inspected

NI=Not Inspected

NP=Not Present

D=Deficient

I	NI	NP	D
---	----	----	---

The following observations, deficiencies and/or exceptions if any associated with the **Floors** that were observed on this structure are noted below



8/22/2022 9:50:42 AM

D - Sub-floor has moisture stains and/or a type of fungal type growth on it in various areas under the house. The sub-floor was mostly covered and the view of the sub-floor was obscured.



8/22/2022 9:55:10 AM



8/22/2022 10:03:29 AM

D - At the time of the inspection multiple floor joists in the crawl space where found to be cracked. Recommend a foundation company further evaluate and repair as needed.



8/22/2022 10:39:13 AM



8/22/2022 10:43:02 AM

D - Water damage was noted to wood floor in the various locations throughout the house.



8/22/2022 10:40:02 AM

D - The floor was soft in One or more areas. It should be monitored for future changes and repaired if needed.

I=Inspected

NI=Not Inspected

NP=Not Present

D=Deficient

I NI NP D



D - Floor slopes are apparent. This condition could indicate greater than normal movement within the structure and potential structural problems. Further investigation may be necessary.

G. Doors (Interior and Exterior)
Comments:

At the time of the Inspection the **Interior and Exterior Doors** appeared to be in **fair condition**.

The items listed below are the Inspectors observations of deficiencies and/or exceptions if any associated with the **Doors** that were noted on this structure at the Time of the Inspection:



D - One or more interior doors swings to the open or closed position. An adjustment may be needed.



D - The glass in the dining room is cracked. Recommend repairs be undertaken.

I=Inspected

NI=Not Inspected

NP=Not Present

D=Deficient

I NI NP D



D - Safety glass etching was not observed on the glass within the door. Safety glass is required for glass doors or doors with glass panes and is generally identified by an etching in the corner of the glass pane.



D - Missing doors should be repaired and/or replaced.



D - Weather strip is torn and/or damaged on the one or more exterior door.



D - The one or more locations interior door appeared to be out of square with the frame.

H. Windows
Comments:

Interior/Exterior Windows Window Screens::

At the time of the Inspection the Inspectors opinion was that the **Interior and Exterior Windows and Window Screens** appeared to be in **fair condition** .

I=Inspected

NI=Not Inspected

NP=Not Present

D=Deficient

I NI NP D

The items listed below are the Inspectors observations of deficiencies and/or exceptions if any associated with the **Windows and screens** that were noted on this structure at the Time of the Inspection:



8/22/2022 11:25:20 AM

D - Your windows would be more efficient if you were to caulk around framing on the exterior. This makes the window more energy efficient and will also prevent moisture from entering around the window into the exterior wall.



8/22/2022 11:25:29 AM

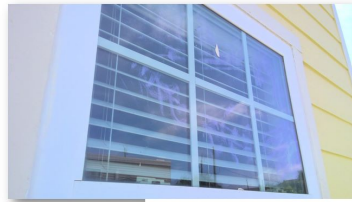

8/22/2022 11:26:28 AM

D - Multiple windows with a broken seal was noted (the specific locations are not given because a window seal could be broken and not noticed for some time). This allows moisture inside between the panes of glass and/or glazing. This causes fogging to take place, which will eventually cause staining to the point of zero visibility.



8/22/2022 11:26:38 AM

D - There are windows on house that appear to be missing the Z flashing over the top of the window. Flashing is needed when the distance from the top of the window to the bottom of the soffit is greater than the width of the soffit. Recommend a window installation company further evaluate and repair as needed.

I. Stairways (Interior and Exterior)

Comments:

Stairs:

In the Inspectors opinion the **Stairs** appeared to be in **fair condition**.

I=Inspected

NI=Not Inspected

NP=Not Present

D=Deficient

I	NI	NP	D
---	----	----	---

The items listed below are the Inspectors observations of deficiencies and/or exceptions if any associated with the **Stairs** that were noted on this structure at the Time of the Inspection:



D - The under portion of the stairs should be finished out with 5/8 inch sheet rock for safety. Recommend repairs be undertaken for safety reasons.



D - The openings in the guard railing are large enough to allow an object larger than 4 inches to pass through. It is recommended that this condition be repaired for improved safety.

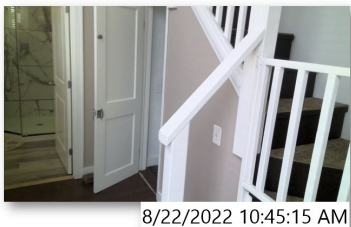

D - 2 X 4 handrails are not graspable and are considered a safety hazard. Recommend repairs be undertaken.

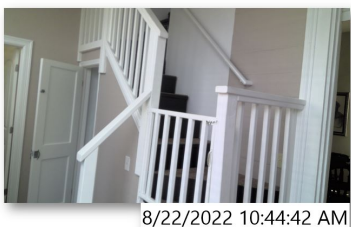

D - The stairway handrail does not run continuous from the bottom of the stairwell to the top of the stairwell so to cover all of the steps (treads). Under current building standards all handrails for the stairway should run continuous for the full length of the flight excluding landings that are a minimum of 36"x36". The handrail should start directly above the lowest step and run continuously to end directly above the top step.

I=Inspected

NI=Not Inspected

NP=Not Present

D=Deficient

I NI NP D



D - The size and/or orientation of the step “risers” may make the stairway difficult to negotiate. This condition should be altered for improved safety.

J. Fireplaces and Chimneys
Comments:

K. Porches, Balconies, Decks, and Carports
Comments:

Porch/Patio:

At the time of the Inspection the Inspectors opinion was that the **Porches/Patios** appeared to be in **acceptable condition** on the day of the Inspection.

L. Cabinets
Comments:

Cabinet/s:

In the Inspectors opinion was that the **Cabinets** appeared to be in **fair condition**.

The items listed below are the Inspectors observations of deficiencies and/or exceptions if any associated with the **Cabinet/s** that were noted on this structure at the Time of the Inspection:



D - Tile and grout is missing on the backsplash in the kitchen. Recommend repairs be undertaken.

M. Sidewalks & Driveways
Comments:

I=Inspected

NI=Not Inspected

NP=Not Present

D=Deficient

I	NI	NP	D
---	----	----	---

N. Fences

Comments:

In the Inspectors opinion was that the **Fences** appeared to be in **acceptable condition**.

I=Inspected

NI=Not Inspected

NP=Not Present

D=Deficient

I NI NP D

II. ELECTRICAL SYSTEMS

A. Service Entrance and Panels

Comments:



Panel Box : General Electric - GE
Box Rating : 200 amps
Box Location: East Exterior Wall
Main Service Entrance: overhead
Type of Main Service Wiring: Copper
Main Disconnect Rating: 200 amps

Main Electrical :

In the Inspectors opinion is the **Main Electrical System** appeared to be in **Operable Condition on the day of the Inspection.**

Whenever a defect and/or deficiency of any kind is noted in the electrical system, we recommend that a qualified, licensed electrician repair and/or service the entire system and/or part.

The items listed below are the Inspectors observations of deficiencies and/or exceptions if any associated with the **Main Electrical Panel/s** that were noted on this structure at the Time of the Inspection:



D - Knock out spaces for the breakers in the breaker box were exposed. Blanks are available that fill these voids at most home improvement stores. The gaps should be filled with snap-on covers.

I=Inspected

NI=Not Inspected

NP=Not Present

D=Deficient

I NI NP D



D - Panel box not labeled properly. Recommend labeling all breakers



D - The main panel cover plate (sometimes called the “dead front”) is missing. The dead front should be in place to prevent accidental access to parts of the hardware that can result in electrocution.

Grounding / Bonding:

A grounding conductor **was** applied and appeared **to be properly** connected.

All boxes and conduit appeared to be bonded properly. I **did not** observe any indications of overheating or arcing within the panel box at the time of the inspection.

- B. Branch Circuits, Connected Devices, and Fixtures**
- Type of Wiring: Copper**
- Comments:**

In the Inspectors opinion is the **Branch service** appeared to be in **fair condition** on the day of the Inspection.

Whenever a defect and/or deficiency of any kind is noted in the electrical system, we recommend that a qualified, licensed electrician repair and/or service the entire system and/or part.

The items listed below are the Inspectors observations of deficiencies and/or exceptions if any associated with the **Branch Service** that were noted on this structure at the Time of the Inspection:

Branch Wires:

I=Inspected

NI=Not Inspected

NP=Not Present

D=Deficient

I NI NP D



D - Loose junction boxes should be properly secured.

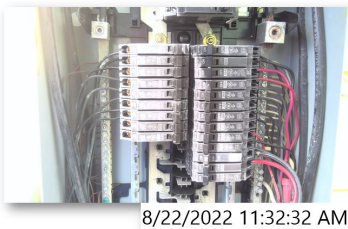

D - There are circuits (15 and 20 amp) that are not Arc-Fault protected according to today building standards. This is a as built condition.

Outlets / Receptacles



D - This structure is not properly protected to current standards by GFCI (ground fault circuit interrupt) breakers. This is a recommended statement by the T.R.E.C. (6/13/94) GFCI breakers are recommended to be installed in accordance with the latest version of the NEC.

2019 National Electrical Code 210.8 Ground-Fault Circuit-Interrupter Protection for Personnel. (A) Dwelling Units. All 125-volt, single-phase, 15- and 20-ampere receptacles installed in the locations specified in (1) through (8) shall have ground-fault circuit-interrupter protection for personnel. Bathrooms Garages - also accessory buildings that have a floor located at or below grade level not intended as habitable rooms and limited to storage areas, work areas, and areas of similar use Outdoors - (Exception to (3): Receptacles that are not readily accessible and are supplied by a dedicated branch circuit for electric snow-melting or deicing equipment shall be permitted to be installed in accordance with 426.28.) Crawl spaces - at or below grade level Unfinished basements - for purposes of this section, unfinished basements are defined as portions or areas of the basement not intended as habitable rooms and limited to storage areas, work areas, and the like Kitchens - where the receptacles are installed to serve the countertop surfaces and dishwashers. Sink receptacles - receptacles that are located within 6 feet of the outside edge of a sink that is located in an area other than a kitchen. Laundry room receptacles. Boathouses

I=Inspected

NI=Not Inspected

NP=Not Present

D=Deficient

I NI NP D

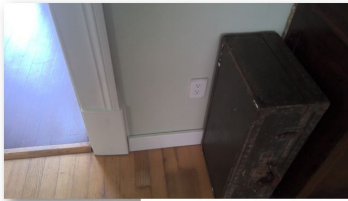

8/22/2022 10:21:17 AM

D - (As built condition) One or more outlets 5.6 feet or lower to the walking surface are not tamper proof (i.e. child safe). These outlets should be further evaluated and repaired as needed.



8/22/2022 10:37:09 AM

D - One or more outlets are loose. Recommend outlets be re-secured.



8/22/2022 11:26:06 AM

D - Exterior receptacles in wet locations are recommended to have bubble covers. Recommend adding the proper covers.

Switches, Fixtures & Fans

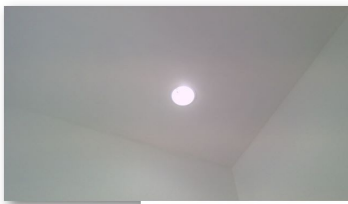

8/22/2022 10:55:32 AM

D - Light fixtures over the a shower should be approved for wet locations. Recommend repairs be undertaken.

C. Door Bell

Comments:

I=Inspected

NI=Not Inspected

NP=Not Present

D=Deficient

I NI NP D

D. Smoke, Fire & Carbon Monoxide Detectors

Comments:

Smoke & Fire Detectors:

In my opinion the **Smoke & Fire Alarms** appeared to be in **fair condition** on the Day of the Inspection.

The smoke detectors are recommended to be hardwired with battery back up and tied to a central alarm system.

It is recommended to replace the batteries in all of the smoke detectors once a year for reasons of safety.

The items listed below are the Inspectors observations of deficiencies and/or exceptions if any associated with the Smoke & Fire Alarms that were noted on this structure at the Time of the Inspection:

D - One or more of the smoke alarms do not appear to be interconnected together. Under today's building standards: When more than one smoke alarm is required to be installed within an individual dwelling unit the alarm devices shall be interconnected in such a manner that the actuation of one alarm will activate all of the alarms in the individual unit. The alarm shall be clearly audible in all bedrooms over background noise levels with all intervening doors closed.

D - There are not enough smoke alarms located in the home. Under current building standards: there should be a smoke alarm located in each sleeping room, outside each separate sleeping area in the immediate vicinity of the sleeping rooms, and on each additional story of the dwelling.

Carbon Monoxide Detectors:

In my opinion the **Carbon Monoxide Detectors** appears to be in **Not located** on the Day of the Inspection.

Your Carbon Monoxide Detector should be no higher than the lowest bed off the floor and should be replaced every two years.

I=Inspected

NI=Not Inspected

NP=Not Present

D=Deficient

I NI NP D

III. HEATING, VENTILATION AND AIR CONDITIONING SYSTEMS

A. Heating Equipment

Type of System: Central unit

Energy Source: Natural gas

Comments:

Unit #1

Date Built: 2010

Brand Name: Luxaire

Today's Avg Temperature Reading: 100 Degrees



8/22/2022 11:22:45 AM

Gas Furnace:



8/22/2022 10:26:12 AM



8/22/2022 11:20:31 AM

On the day and time of the inspection it is my opinion that the **Gas Furnace** appeared to be in **Operable Condition**

The items listed below are the Inspectors observations of deficiencies and/or exceptions if any associated with the **Gas Furnace** that were noted on this structure at the Time of the Inspection:

NI - A full evaluation of the integrity of a heat exchanger requires dismantling of the furnace and is beyond the scope of this visual inspection. (This is a specific T.R.E.C. guideline limitation).

I=Inspected

NI=Not Inspected

NP=Not Present

D=Deficient

I NI NP D



D - Rust was noted on the burners of the furnace. This can effect the proper operation of the furnace. The burners should be cleaned and the heat exchanger inspected for defects by a Qualified Certified & Licensed HVAC Specialist.



D - The closet was not fire stopped. 5/8" drywall should be installed to seal the closet and give a 20 minute fire rating.



D - Flue vents in the attic were touching and/or too close to combustibile material. This is a potential fire hazard. Recommend repairs be undertaken.

It is recommended to have the heating unit checked and serviced by a [Licensed/Certified/Qualified HVAC Company](#). The observations made to support the rendering of this opinion are listed but may not be limited to the following:

-
-
-
-

B. Cooling Equipment

Type of System: central - air conditioner, window units

Comments:

Unit #1

Approximate System Age: 2016

Approximate System Size: 4 ton

Brand Name: American Standard

The Unit was tested with the following results applying:

I=Inspected

NI=Not Inspected

NP=Not Present

D=Deficient

I NI NP D



8/22/2022 10:32:38 AM



8/22/2022 10:32:00 AM

The output temperature = 70° and the input temperature = 76° for a differential of 6° (normal range 15° - 22°). These temperatures are **within** the recommended tolerances.

Temperature differential readings are a fundamental standard for testing the proper operation of the cooling system. The normal acceptable range is considered approximately between 15 to 22 degrees F. total difference between the return air and supply air. Unusual conditions such as excessive humidity, low outdoor temperatures, and restricted airflow may indicate abnormal operation even through the equipment is functioning basically as designed and occasionally may indicate normal operation in spite of an equipment malfunction.

Cooling System:



8/22/2022 11:23:44 AM



8/22/2022 11:24:01 AM

At the time of the inspection it is my opinion the **Cooling system & equipment** appeared to be in **poor condition** on the Day of the Inspection.

It is recommended that the unit be serviced now as well as annually. Having the coils cleaned allows the unit to perform as intended and avoids costly repairs.

The items listed below are the Inspectors observations of deficiencies and/or exceptions if any associated with the **Cooling System** that were noted on this structure at the Time of the Inspection:



8/22/2022 10:29:04 AM

NI-The evaporator coils and drip pan could not be inspected due to the vent duct and the inspection cover being sealed.

I=Inspected

NI=Not Inspected

NP=Not Present

D=Deficient

I	NI	NP	D
---	----	----	---



D - The moisture sensor is not installed as it should be. Recommend repairs be undertaken.



D - The outside A/C unit should be strapped and secured to the structure.



D - The air conditioning system was not cooling as it should at the time of the inspection. A Qualified Certified & Licensed HVAC Specialist should be consulted to further evaluate of this condition and the remedies available for correction.

It is recommended to have the cooling unit checked and serviced by a [Licensed/Certified/Qualified HVAC Company](#). The observations made to support the rendering of this opinion are listed but may not be limited to the following:

Thermostat



The Thermostat/s is located in the dining room.

I=Inspected

NI=Not Inspected

NP=Not Present

D=Deficient

I	NI	NP	D
---	----	----	---

On the day and time of the inspection it is my opinion that the **Thermostat** appeared to be in **Operable Condition**

Unit 2

Year Built:: Unable To Determine

Approximate System Size: Unable To Determine

Brand Name: LG

The Unit was tested with the following results applying:



The output temperature = **55°** and the input temperature = **70°** for a differential of **15°** (normal range 14° - 23°). These temperatures are **within** the recommended tolerances.

Cooling System:

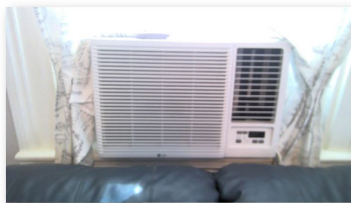

At the of the time of the inspection it is my opinion the **cooling system & equipment** appeared to be in **Operable Condition** on the Day of the Inspection.

The items listed below are the Inspectors observations of deficiencies and/or exceptions if any associated with the **Cooling System** that were noted on this structure at the Time of the Inspection:



D - The window unit is not supported as it should be. Recommend repairs be undertaken

I=Inspected

NI=Not Inspected

NP=Not Present

D=Deficient

I NI NP D

It is recommended to have the cooling unit checked and serviced by a [Licensed/Certified/Qualified HVAC Company](#). The observations made to support the rendering of this opinion are listed but may not be limited to the following:

Thermostat

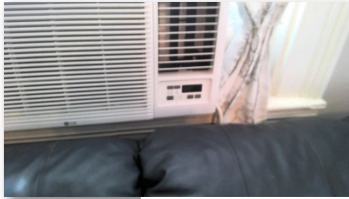

8/22/2022 10:34:16 AM

The Thermostat/s is located in the At the unit .

On the day and time of the inspection it is my opinion that the **Thermostat** appeared to be in **Operable Condition**

C. Duct Systems, Chases, and Vents

Comments:

Duct & Filter System

Filter Size: 20 x 25

Location: Wall Mounted

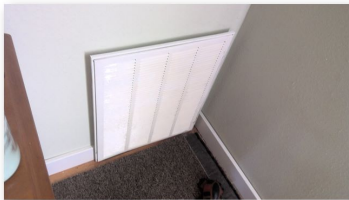

8/22/2022 10:20:35 AM

Supply & Return Air Ducts:

The **Supply & Return & Duct system** appeared to be in **acceptable condition** and appears to have equal distribution.

I=Inspected

NI=Not Inspected

NP=Not Present

D=Deficient

I NI NP D

IV. PLUMBING SYSTEMS

A. Plumbing Supply, Distribution Systems and Fixtures

Location of water meter: Front Yard

Location of main water supply valve: at meter box

Static water pressure reading: 50 to 55 psi

Type of supply piping material: CPVC

Comments:

Plumbing supply location:crawl space

This structure has **1.5 bathrooms**. Cold and/or Hot water faucets were run **3 Faucets** for approximately **30** minutes at a rate of **1.0** gallon per minute per faucet, for a total estimate of approximately **90 gallons** that flowed through the drains. Functional flow **was** present in this structure:

The Inspector has attempted to discover and report conditions requiring further evaluation or repair. However; determining the condition of any component that is not visible and/or accessible, such as plumbing components that are buried, beneath the foundation, located within construction voids or otherwise concealed, and reporting any deficiency that does not appear or become evident during our limited cursory and visual survey is outside the scope of this inspection.

Water Supply:

The **Water Supply System** appeared to be in **acceptable condition** on the day of the Inspection

Static water pressure test.



The **Static water pressure** appeared to be in **acceptable condition** on the day of the Inspection

Exterior Faucet/s:

The **Exterior Faucets** appeared to be in **fair condition** on the day of the Inspection

The items listed below are the Inspectors observations of deficiencies and/or exceptions if any associated with the **Exterior Faucets** that were noted on this structure at the Time of the Inspection:

I=Inspected

NI=Not Inspected

NP=Not Present

D=Deficient

I	NI	NP	D
---	----	----	---

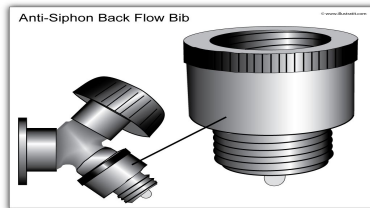

D - One or more of the exterior water hose bib's (faucet) do not have a back-flow or anti-siphon device (Vacuum Breakers) in place. Note: This is not uncommon to observe with a home of this age.

Kitchen and Utility Sinks:

The **Kitchen and or Utility Sinks Plumbing Fixtures** appeared to be in **acceptable condition** on the day of the Inspection

Bathrooms:

The **Bathrooms Plumbing Fixtures** appeared to be in **fair condition** on the day of the Inspection

The items listed below are the Inspectors observations of deficiencies and/or exceptions if any associated with the **Bathrooms Plumbing Fixtures** that were noted on this structure at the Time of the Inspection:



D - The hot and cold faucets in the bathroom shower are reversed and should be repaired.

Laundry Fixtures:

The **Laundry Fixtures** appeared to be in **acceptable condition** on the day of the Inspection

The items listed below are the Inspectors observations of deficiencies and/or exceptions if any associated with the **Laundry Fixtures** that were noted on this structure at the Time of the Inspection:

I=Inspected

NI=Not Inspected

NP=Not Present

D=Deficient

I NI NP D



NI-The plumbing fixtures were blocked by an installed washing machine. These fixtures are prone to leaks when the valve is turned off and the appliance is disconnected. These fixtures could not be inspected.

- B. Drains, Wastes, and Vents
- Type of drain piping material: PVC*
- Comments:*

Plumbing Drains & Vents

The **Plumbing Drains & Vents** appeared to be in **fair condition** on the day of the Inspection.

Reporting the condition of drains, wastes and vent piping that is not completely visible or accessible, or reporting any defect or deficiency that requires extended use of the system to develop or does not become evident during our limited cursory and visual survey is outside the scope of the inspection. This is a limited cursory and visual survey of the accessible general conditions and circumstances present at the time of this inspection. Opinions are based on general observations made without the use of specialized tools or procedures. Therefore, the opinions expressed are one of apparent conditions and not of absolute fact and are only good for the date and time of this inspection.

The items listed below are the Inspectors observations of deficiencies and/or exceptions if any associated with the plumbing drains & vents that were noted on this structure at the Time of the Inspection:



NI-The plumbing drain was blocked by an installed washing machine. This drain could not be inspected.

I=Inspected

NI=Not Inspected

NP=Not Present

D=Deficient

I NI NP D



8/22/2022 9:23:50 AM



8/22/2022 9:24:11 AM



8/22/2022 9:25:03 AM

BN - The drain line was scoped on the day of the inspection and deficiencies were found at that time.



8/22/2022 10:50:02 AM

BN - There is flex pipe under the bathroom sinks. This type of pipe is commonly used for temporary repairs. Due to the flex pipe trapping solids a plumber should further evaluate.



8/22/2022 10:49:56 AM

D - An "S" trap was noted at the bathroom sink drains. This type of drain is not an approved drain. I recommend having the drains inspected by a Qualified, Certified & Licensed Plumbing Specialist.

C. Water Heating Equipment

Energy Source:Electric

Capacity: 40 Gallons

Comments:

Unit 1:

General Electric - GE

Approximate Year Manufactured: **2011**

Location: Utility Room Closet Expansion Tank Applied:**No**

Water Temp: **101 Degrees** Recommended Hot Water setting should between **115 – 120°**



8/22/2022 11:09:46 AM

I=Inspected

NI=Not Inspected

NP=Not Present

D=Deficient

I	NI	NP	D
---	----	----	---

Water Heater:



8/22/2022 11:11:17 AM

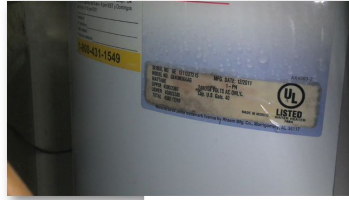

8/22/2022 11:11:27 AM



8/22/2022 11:19:51 AM

The **Water Heater** appeared to be in **poor condition** on the Day of the Inspection.

The items listed below are the Inspectors observations of deficiencies and/or exceptions if any associated with the **Water Heating System** that were noted on this structure at the Time of the Inspection:

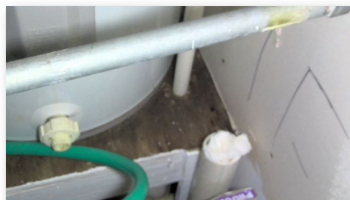

8/22/2022 11:12:03 AM

D - The temperature and pressure relief discharge pipe is terminating into the crawl space area. Under current building standards, this discharge pipe should run downward to the exterior of the structure, turn downward, and terminate within 6-inches of the ground.



8/22/2022 11:12:11 AM

D - Safety pan underneath the water heater is missing. A Safety Pan is required if the Heater can leak and will cause damage. T.R.E.C. requires to report that a water heater in areas that will cause damage if it leaks and does not have safety pan underneath and that is properly piped to the outside of the structure or to a drain.

I=Inspected

NI=Not Inspected

NP=Not Present

D=Deficient

I NI NP D



D - Water tank is showing signs of rusting along the bottom or top rim. Recommend a periodic check on the tanks condition.



D - The bottom heating element for the the water heater was found not to working at the time of the inspection. Recommend a plumbing company further evaluate and repair as needed.

D. Hydro-Massage Therapy Equipment
Comments:

Hydro- Therapy Tub:

The **Hydro-Massage Therapy Equipment** appeared to be in **poor condition** on the day of the Inspection.

The items listed below are the Inspectors observations of deficiencies and/or exceptions if any associated with the **Hydro-Massage System** that were noted on this structure at the Time of the Inspection:



D-I was unable to locate a ground fault circuit interrupter (GFCI) receptacle or breaker for the hydro-massage therapy equipment. The homeowner should be consulted on the location of this GFCI device. If there is no GFCI device installed on the hydro-massage therapy equipment circuit, a GFCI receptacle or breaker should be installed for reasons of safety.

International Residential Code for One & Two Family Dwellings
SECTION E4109 HYDRO MASSAGE BATHTUBS

I=Inspected

NI=Not Inspected

NP=Not Present

D=Deficient

I NI NP D

E4109.1 Ground-fault circuit-interrupters. Hydro massage bathtubs and their associated electrical components shall be protected in accordance with Section E4108. All 125-volt, single-phase receptacles not exceeding 30 amperes and located within 5 feet (1524 mm) measured horizontally of the inside walls of a hydro massage tub shall be protected by a designated ground-fault circuit interrupter(s).

E4109.2 Other electric equipment. Luminaries, switches, receptacles, and other electrical equipment located in the same room, and not directly associated with a hydro massage bathtub, shall be installed in accordance with the requirements of this code relative to the installation of electrical equipment in bathrooms.



8/22/2022 10:47:07 AM

D - The control is damaged on the tub. Recommend repairs be undertaken.



8/22/2022 10:48:16 AM

D - The whirlpool bath was inoperative at the time of the inspection. This should be investigated further and repairs undertaken, if necessary.

- E. Gas Distribution Systems and Gas Appliances**
- Location of gas meter: West Side*
- Type of gas distribution piping material: Galvanized*
- Comments:*

Gas Distribution System and Gas Appliances:

On the day of the inspection it was the Inspectors opinion the **Gas Distribution System & components** appeared to be in **poor condition** at the time of this inspection.

Scope: The Inspector shall inspect and report deficiencies in the condition of all accessible and visible gas pipes and test the gas lines using a local and/or industry accepted procedure. The Inspector will use a combustible gas leak detector on all the accessible gas lines, joints, unions and connectors and report as in need of repair, any deficiencies found at the time and date of the inspection.

I=Inspected

NI=Not Inspected

NP=Not Present

D=Deficient

I	NI	NP	D
---	----	----	---

The items listed below are the Inspectors observations of deficiencies and/or exceptions if any associated with the **Gas Supply System** that were noted on this structure at the Time of the Inspection:



8/22/2022 10:05:53 AM

D - The galvanized gas line under the house in the crawl space is showing signs of rust. Recommend a plumbing company further evaluate and repair as needed.



8/22/2022 10:06:09 AM

D - The gas pipe is not supported as it should be. Recommend repairs be undertaken.

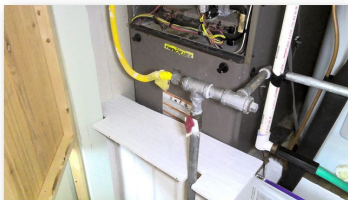

8/22/2022 10:28:10 AM

D - The heater gas supply line is not equipped with a sediment trap just before the gas appliance connector. This condition does not meet current installation requirements and should be corrected.

Samples of correct sediment trap installations

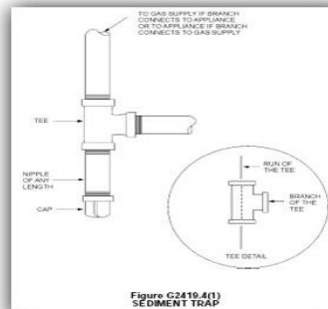

I=Inspected

NI=Not Inspected

NP=Not Present

D=Deficient

I NI NP D

International Residential Code for One & Two Family Dwellings G2419.4 (408.4) Sediment trap. Where a sediment trap is not incorporated as part of the appliance, a sediment trap shall be installed downstream of the appliance shutoff valve as close to the inlet of the appliance as practical. The sediment trap shall be either a tee fitting having a capped nipple of any length installed vertically in the bottommost opening of the tee as illustrated in Figure G2419.4 or other device approved as an effective sediment trap. Illuminating appliances, ranges, clothes dryers, decorative vented appliances for installation in vented fireplaces, gas fireplaces, and outdoor grills need not be so equipped.

I=Inspected NI=Not Inspected NP=Not Present D=Deficient

I	NI	NP	D
---	----	----	---

V. APPLIANCES

 A. Dishwashers
Comments:

 B. Food Waste Disposers
Comments:

 C. Range Hood and Exhaust Systems
Comments:

The **Range Hood** appears to be in **Missing** at the time of inspection with the following observations, deficiencies and/or exceptions being noted on this structure:

The items listed below are the Inspectors observations of deficiencies and/or exceptions if any associated with the **Range Hood System** that were noted on this structure at the Time of the Inspection:



D - The range hood over the range is missing. When the cook top or range is gas a range hood is required. Recommend repairs be undertaken.

 D. Ranges, Cooktops, and Ovens
Comments:
Manufacturer: Whirlpool



At the time of the inspection it is the Inspectors opinion that the **Range** appeared to be in **Operable Condition**.

The items listed below are the Inspectors observations of deficiencies and/or exceptions if any associated with the **Range, Cook top or Ovens System** that were noted on this structure at the Time of the Inspection:

Gas Range:

I=Inspected

NI=Not Inspected

NP=Not Present

D=Deficient

I NI NP D

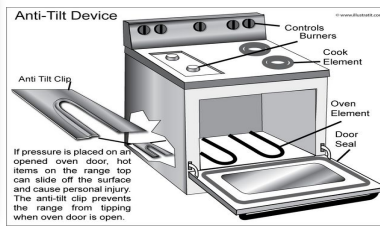

D - Oven is not properly secured to the surrounding cabinet and/or wall. Children can tip the oven over if the door is used as a stepping stool. All ovens are now required to be secured in some fashion. An anti tip device should be installed.



D - A handle on the gas range is loose and parts are missing ant the top of the door. Recommend repairs be undertaken.



D - The oven light in the range is inoperative and the lense cover is missing. Recommend repairs be undertaken.



D - The gas shut off is behind the range and is hard to reach. The gas shut off must be in the same room and easy to access. Recommend repairs be undertaken for safety reasons.

Oven Temperature:

I=Inspected

NI=Not Inspected

NP=Not Present

D=Deficient

I NI NP D



This unit is controlled by gas. It was not tested for Carbon Monoxide production. If this is a concern, please contact a licensed plumbing professional.

E. Microwave Ovens
Comments:

F. Mechanical Exhaust Vents and Bathroom Heaters
Comments:

At the time of the inspection it is the Inspectors opinion that the **Mechanical Exhaust Fan / Heaters and components** appeared to be in **poor condition**.

The items listed below are the Inspectors observations of deficiencies and/or exceptions if any associated with the **Mechanical Exhaust Fan and Heater** that were noted on this structure at the Time of the Inspection:

Bathroom Exhaust Fans and Heaters:



D - Bathroom exhaust fan did not operate properly at the time of inspection. In some rare cases a stuck motor can become a fire hazard. A malfunctioning exhaust fan should be repaired or replaced.

G. Garage Door Operators
Comments:

H. Dryer Exhaust Systems
Comments:

At the time of the inspection it is the Inspectors opinion the **Dryer Vent component** appeared to be in **poor condition**.

I=Inspected

NI=Not Inspected

NP=Not Present

D=Deficient

I	NI	NP	D
---	----	----	---

The items listed below are the Inspectors observations of deficiencies and/or exceptions if any associated with the **Dryer Vent System** that were noted on this structure at the Time of the Inspection:

BN - Recommend having the dryer vent cleaned.



D - The dryer is vented into the crawl space. The dryer should vent to the exterior of the home.

DEFICIENCY SUMMARY

This is a summary of deficiency's ONLY in the report

FOUNDATIONS

- ◆ **D - A moisture barrier should be installed on the crawl space floor.**
- ◆ **D - Evidence of Previous and damage of wood destroying insects (subterranean termites ext.) was detected in various areas of the crawlspace on the underside of the structure at the time of inspection.** Full evaluation of the amount of damage caused by the insects cannot be detected within the walls, voids, or other hidden areas without defacing the property and cannot be addressed in this report. With the detection of active and/or previous activity of a wood destroying insect, it should be assumed that some degree of damage is present. I recommend that a more evasive inspection be conducted by a licensed pest control company prior to closing. The author of this report is also licensed by the SPCB #12100.
- ◆ **D - Termite shield should be added to the top of the piers.** Recommend repairs be undertaken.
- ◆ **D - The brick piers need to be re-pointed.** Recommend repairs be undertaken.
- ◆ **D - Evidence of moisture damage was noted at but may not be limited to side entry.** Water damaged materials are considered a conducive condition for water penetration and insect infestation. Whenever water damaged materials are noted in this report, we recommend consulting a qualified specialist so that a corrective course of action can be evaluated.
- ◆ **D - Beams in multiple areas of the house are damaged.** Recommend a foundation company further evaluate and repair as needed.
- ◆ **D - There is not enough piers and beams supporting the home.** There should be piers every 6 feet no further the 8 feet apart. Recommend a foundation company further evaluate and repair as needed.
- ◆ **D - Crawl space has wood to ground contact through out the crawl space.** Wood to ground contact allows wood destroying insects (termites) to enter the home. Homeowner needs to remove wood to ground contact and have annual inspections of these areas.

GRADING AND DRAINAGE

- ◆ **D - Poor, flat or negative site drainage was observed around the structure .** Proper drainage is needed to help prevent water from standing or ponding next to the perimeter beam. Corrective measures may be needed if water stands within 10 feet of the perimeter beam for more than 24 hours.
- ◆ **D - Structure has heavy foliage.** Recommend trimming foliage away from structure to reduce the possibility of insects' invasion. (I.e. Carpenter ants).

ROOF STRUCTURES AND ATTICS

- ◆ **D - The attic space was not accessible at the time of inspection.** It is recommended access be provided for proper inspection.
- ◆ **D - The level of ventilation should be improved.** It is generally recommended that one (1) square foot of free vent area be provided for every one hundred and fifty (150) square feet of ceiling area. Proper ventilation will help to keep the house cooler during warm weather and extend the life of roofing materials. In colder climates, it will help reduce the potential for ice dams on the roof and condensation within the attic.

WALLS (INTERIOR AND EXTERIOR)

- ◆ **D - Common hairline wall cracks were noted in the interior wallboard.** Cracks near the interior windows and doors are usually indications that there is some degree of movement occurring in the structure. (In any structure some degree of movement is normal and should not be of concern) the severity of the cracks can be an indication of the amount of movement in a structure.
- ◆ **D - There are areas on the exterior wall that are in need of caulking.** Any area where moisture can penetrate between the exterior and interior wall should be kept water tight.
- ◆ **D - Exterior paint / stain are peeling or are showing signs of wear in several areas** Exposed or weathered wood is considered a condition conducive for wood decay and water penetration. The T.R.E. C. Limitations states the inspector is not required to determining the condition of paints, stains, or other surface coatings.
- ◆ **D - Soft, damaged or decayed cladding was noted on the exterior trim and siding** Recommend replacing all water damaged wood.
- ◆ **D-The sidewall veneer is in contact with the roofing material.** Under current building standards, there should be at least 2-inch of clearance between the roofing material and the sidewall veneer. This will help to eliminate the rotting of the wood siding used on the wall from storm water and moisture exposure.

CEILING AND FLOORS

- ◆ **D - Sub-floor has moisture stains and/or a type of fungal type growth on it in various areas under the house.** The sub-floor was mostly covered and the view of the sub-floor was obscured.
- ◆ **D - At the time of the inspection multiple floor joists in the crawl space where found to be cracked.** Recommend a foundation company further evaluate and repair as needed.
- ◆ **D - Water damage was noted to wood floor in the various locations throughout the house.**
- ◆ **D - The floor was soft in One or more areas.** It should be monitored for future changes and repaired if needed.
- ◆ **D - Floor slopes are apparent.** This condition could indicate greater than normal movement within the structure and potential structural problems. Further investigation may be necessary.

DOORS (INTERIOR AND EXTERIOR)

- ◆ **D - One or more interior doors swings to the open or closed position.** An adjustment may be needed.
- ◆ **D - The glass in the dining room is cracked.** Recommend repairs be undertaken.
- ◆ **D - Safety glass etching was not observed on the glass within the door.** Safety glass is required for glass doors or doors with glass panes and is generally identified by an etching in the corner of the glass pane.
- ◆ **D - Missing doors should be repaired and/or replaced.**
- ◆ **D - Weather strip is torn and/or damaged on the one or more exterior door.**
- ◆ **D - The one or more locations interior door appeared to be out of square with the frame.**

WINDOWS

- ◆ **D - Your windows would be more efficient if you were to caulk around framing on the exterior.** This makes the window more energy efficient and will also prevent moisture from entering around the window into the exterior wall.

- ◆ **D - Multiple windows with a broken seal was noted** (the specific locations are not given because a window seal could be broken and not noticed for some time). This allows moisture inside between the panes of glass and/or glazing. This causes fogging to take place, which will eventually cause staining to the point of zero visibility.
- ◆ **D - There are windows on house that appear to be missing the Z flashing over the top of the window.** Flashing is needed when the distance from the top of the window to the bottom of the soffit is greater than the width of the soffit. Recommend a window installation company further evaluate and repair as needed.

STAIRWAYS (INTERIOR AND EXTERIOR)

- ◆ **D - The under portion of the stairs should be finished out with 5/8 inch sheet rock for safety.** Recommend repairs be undertaken for safety reasons.
- ◆ **D - The openings in the guard railing are large enough to allow an object larger than 4 inches to pass through.** It is recommended that this condition be repaired for improved safety.
- ◆ **D - The openings in the guard railing are large enough to allow an object larger than 4 inches to pass through.** It is recommended that this condition be repaired for improved safety.
- ◆ **D - 2 X 4 handrails are not graspable and are considered a safety hazard.** Recommend repairs be undertaken.
- ◆ **D - The stairway handrail does not run continuous from the bottom of the stairwell to the top of the stairwell so to cover all of the steps (treads).** Under current building standards all handrails for the stairway should run continuous for the full length of the flight excluding landings that are a minimum of 36"x36". The handrail should start directly above the lowest step and run continuously to end directly above the top step.
- ◆ **D - The size and/or orientation of the step "risers" may make the stairway difficult to negotiate.** This condition should be altered for improved safety.

CABINETS

- ◆ **D - Tile and grout is missing on the backsplash in the kitchen.** Recommend repairs be undertaken.

SERVICE ENTRANCE AND PANELS

- ◆ **D - Knock out spaces for the breakers in the breaker box were exposed.** Blanks are available that fill these voids at most home improvement stores. The gaps should be filled with snap-on covers.
- ◆ **D - Panel box not labeled properly.** Recommend labeling all breakers
- ◆ **D - The main panel cover plate (sometimes called the "dead front") is missing.** The dead front should be in place to prevent accidental access to parts of the hardware that can result in electrocution.

BRANCH CIRCUITS, CONNECTED DEVICES, AND FIXTURES

- ◆ **D - Loose junction boxes should be properly secured.**
- ◆ **D - There are circuits (15 and 20 amp) that are not Arc-Fault protected according to today building standards.** This is a as built condition.
- ◆ **D - This structure is not properly protected to current standards by GFCI (ground fault circuit interrupt) breakers.** This is a recommended statement by the T.R.E.C. (6/13/94) GFCI breakers are recommended to be installed in accordance with the latest version of the NEC.
- ◆ **D - (As built condition) One or more outlets 5.6 feet or lower to the walking surface are not tamper proof**

(i.e. child safe). These outlets should be further evaluated and repaired as needed.

- ◆ **D - One or more outlets are loose.** Recommend outlets be re-secured.
- ◆ **D - Exterior receptacles in wet locations are recommended to have bubble covers.** Recommend adding the proper covers.
- ◆ **D - Light fixtures over the a shower should be approved for wet locations.** Recommend repairs be undertaken.

SMOKE, FIRE & CARBON MONOXIDE DETECTORS

- ◆ **D - One or more of the smoke alarms do not appear to be interconnected together. Under today's building standards:** When more than one smoke alarm is required to be installed within an individual dwelling unit the alarm devices shall be interconnected in such a manner that the actuation of one alarm will activate all of the alarms in the individual unit. The alarm shall be clearly audible in all bedrooms over background noise levels with all intervening doors closed.
- ◆ **D - There are not enough smoke alarms located in the home. Under current building standards:** there should be a smoke alarm located in each sleeping room, outside each separate sleeping area in the immediate vicinity of the sleeping rooms, and on each additional story of the dwelling.

HEATING EQUIPMENT

- ◆ **D - Rust was noted on the burners of the furnace.** This can effect the proper operation of the furnace. The burners should be cleaned and the heat exchanger inspected for defects by a Qualified Certified & Licensed HVAC Specialist.
- ◆ **D - The closet was not fire stopped.** 5/8" drywall should be installed to seal the closet and give a 20 minute fire rating.
- ◆ **D - Flue vents in the attic were touching and/or too close to combustible material.** This is a potential fire hazard. Recommend repairs be undertaken.

COOLING EQUIPMENT

- ◆ **D - The moisture sensor is not installed as it should be.** Recommend repairs be undertaken.
- ◆ **D - The outside A/C unit should be strapped and secured to the structure.**
- ◆ **D - The air conditioning system was not cooling as it should at the time of the inspection.** A Qualified Certified & Licensed HVAC Specialist should be consulted to further evaluate of this condition and the remedies available for correction.
- ◆ **D - The window unit is not supported as it should be.** Recommend repairs be undertaken

PLUMBING SUPPLY, DISTRIBUTION SYSTEMS AND FIXTURES

- ◆ **D - One or more of the exterior water hose bib's (faucet) do not have a back-flow or anti-siphon device (Vacuum Breakers) in place.** Note: This is not uncommon to observe with a home of this age.
- ◆ **D - The hot and cold faucets in the bathroom shower are reversed and should be repaired.**

DRAINS, WASTES, AND VENTS

- ◆ **D - An "S" trap was noted at the bathroom sink drains.** This type of drain is not an approved drain. I recommend having the drains inspected by a Qualified, Certified & Licensed Plumbing Specialist.

WATER HEATING EQUIPMENT

- ◆ **D - The temperature and pressure relief discharge pipe is terminating into the crawl space area.** Under current building standards, this discharge pipe should run downward to the exterior of the structure, turn downward, and terminate within 6-inches of the ground.
- ◆ **D - Safety pan underneath the water heater is missing.** A Safety Pan is required if the Heater can leak and will cause damage. T.R.E.C. requires to report that a water heater in areas that will cause damage if it leaks and does not have safety pan underneath and that is properly piped to the outside of the structure or to a drain.
- ◆ **D - Water tank is showing signs of rusting along the bottom or top rim.** Recommend a periodic check on the tanks condition.
- ◆ **D - The bottom heating element for the the water heater was found not to working at the time of the inspection.** Recommend a plumbing company further evaluate and repair as needed.

HYDRO-MASSAGE THERAPY EQUIPMENT

- ◆ **D-I was unable to locate a ground fault circuit interrupter (GFCI) receptacle or breaker for the hydro-massage therapy equipment.** The homeowner should be consulted on the location of this GFCI device. If there is no GFCI device installed on the hydro-massage therapy equipment circuit, a GFCI receptacle or breaker should be installed for reasons of safety.
- ◆ **D - The whirlpool bath was inoperative at the time of the inspection.** This should be investigated further and repairs undertaken, if necessary.

GAS DISTRIBUTION SYSTEMS AND GAS APPLIANCES

- ◆ **D - The galvanized gas line under the house in the crawl space is showing signs of rust.** Recommend a plumbing company further evaluate and repair as needed.
- ◆ **D - The gas pipe is not supported as it should be.** Recommend repairs be undertaken.
- ◆ **D - The heater gas supply line is not equipped with a sediment trap just before the gas appliance connector.** This condition does not meet current installation requirements and should be corrected.

RANGE HOOD AND EXHAUST SYSTEMS

- ◆ **D - The range hood over the range is missing.** When the cook top or range is gas a range hood is required. Recommend repairs be undertaken.

RANGES, COOKTOPS, AND OVENS

- ◆ **D - Oven is not properly secured to the surrounding cabinet and/or wall.** Children can tip the oven over if the door is used as a stepping stool. All ovens are now required to be secured in some fashion. An anti tip device should be installed.
- ◆ **D - A handle on the gas range is loose and parts are missing ant the top of the door.** Recommend repairs be undertaken.
- ◆ **D - The oven light in the range is inoperative and the lense cover is missing.** Recommend repairs be undertaken.
- ◆ **D - The gas shut off is behind the range and is hard to reach.** The gas shut off must be in the same room and easy to access. Recommend repairs be undertaken for safety reasons.

MECHANICAL EXHAUST VENTS AND BATHROOM HEATERS

- ◆ **D - Bathroom exhaust fan did not operate properly at the time of inspection.** In some rare cases a stuck motor can become a fire hazard. A malfunctioning exhaust fan should be repaired or replaced.

DRYER EXHAUST SYSTEMS

- ◆ **D - The dryer is vented into the crawl space. The dryer should vent to the exterior of the home.**

TURN KEY HOME INSPECTION AGREEMENT

This INSPECTION AGREEMENT (herein after known as the Agreement) is entered into on this the day 08/22/2022 between Turn Key Home Inspection and the (Inspector name and TREC license number) Tom Langley TREC #20644 (herein after known as the Inspector) and Danny & Tamra Duarte herein after known as the Client).

The Property to be inspected is (hereinafter as the Property@):
5816 Maco St Galveston, TX 77551

Date of Inspection: 08/22/2022 Time of Inspection : 9:00 am

Inspection Fee: \$586.00 Paid at time of Inspection Credit Card

PLEASE READ THIS AGREEMENT CAREFULLY BEFORE SIGNING

I. Scope of Services

- A. In exchange for the Inspection Fee paid by Client, the Inspector agrees to provide the Client with an Inspection Report setting out the Inspector=s professional opinions concerning the condition of the Property further described in the report. The inspection will be performed in accordance with the Texas Standards of Practice promulgated by the Texas Real Estate Commission and/or the Texas Department of Agriculture ie: Structural Pest Control Service. Inspector will attempt to identify major defects and problems with the Property. **However, Client acknowledges that the Inspection Report may not identify all deficiencies, defects or problems.**
- B. The Inspector agrees to:
1. inspect items, parts, systems, components and conditions which are present and visible at the time of the inspection, but the inspector is not required to determine or estimate the remaining life expectancy or future performance of any inspected item, part, system or component;
 2. operate mechanical and electrical equipment, systems, and appliances during an inspection in normal modes and operating range at the time of the inspection;
 3. report which of the parts, components, and systems present in the property have or have not been inspected;
 4. report as deficient inspected parts, components or systems that are not functioning or that the standards of practice required the inspector to report as Deficient; and
 5. address all of the parts, components, and systems contained in the standards of practice in the property being inspected.

- C. The inspection is limited to those items which can be seen, easily accessed and/or operated by the Inspector at the time of the inspection as set out in the Inspection Report. Inspector will not remove walls, floors, wall coverings, floor coverings and other obstructions in order to inspect concealed items. Systems and conditions which are not specifically addressed in the Inspection Report are excluded. The major systems which will be inspected include:
1. Foundation; Grading & Drainage
 2. Interior doors, wall, ceilings and floors;
 3. Exterior walls and doors, windows and door glazing;
 4. Fireplace and chimney;
 5. Roof, Roof Structure and attic;
 6. Porches, Balconies and decks;
 7. Built-in Appliances;
 8. Heating, cooling and Vent Systems;
 9. Plumbing Supply & Drains, Water Heating System; and
 10. Electrical system.
- D. The Inspector may indicate one of the following opinions of the Inspector regarding a particular item:
1. The item is performing its intended function at the time of the inspection;
 2. The item is in need of replacement or service for repair; or
 3. Further evaluation by a technician or expert is recommended.

II. Inspection Report

- A. The Inspection Report provided by the Inspector will contain the Inspector=s professional, good-faith opinions concerning the need for repair or replacement of certain observable items. All statements in the report are the Inspector=s opinions and should not be construed as statements of fact or factual representations concerning the Property. **By signing this Agreement, the Client understands that the services provided by the Inspector fall within the Professional Services Exemption of the Texas Deceptive Trade Practices Act (DTPA) and agrees that no cause of action exists under the DTPA related to the services provided.** Unless specifically stated, the report will not include and should not be read to indicate opinions as to the environmental conditions, presence of toxic or hazardous waste or substances, presence of termites or other wood-destroying organisms, or compliance with codes, ordinances, statutes or restrictions or the insurability, efficiency, quality, durability, future life or future performance of any item inspected.
- B. The Inspection Report is not a substitute for disclosures by sellers and real estate agents. Said disclosure statements should be carefully read for any material facts that may influence or affect the desirability and/or market value of the Property.
- C. As noted above, the Inspection Report may state that further evaluation of certain items is needed by an expert in the field of the item inspected. By signing this Agreement, Client acknowledges that qualified experts may be needed to further evaluate such items as structural systems, foundations, grading, drainage, roofing, plumbing, electrical systems, HVAC, appliances, sprinkler systems, fire/smoke detection systems, septic systems and other observable items as noted in the report.

III. Disclaimer of Warranties

The inspector makes no guarantee or warranty, express or implied, as to any of the following:

1. That all defects have been found or that the Inspector will pay for repair of undisclosed defects;
2. That any of the items inspected are designed or constructed in a good and workmanlike manner;
3. That any of the items inspected will continue to perform in the future as they are performing at the time of the inspection; and
4. That any of the items inspected are merchantable or fit for any particular purpose.

IV. Wood Destroying Insect Reports

SCOPE OF INSPECTION

- A. This inspection covers only the multi-family structure, primary dwelling or place of business. Sheds, detached garages, lean-tos, fences, guest houses or any other structure will not be included in this inspection report unless specifically noted in Section 5 of this report.
- B. This inspection is limited to those parts of the structure(s) that are visible and accessible at the time of the inspection. Examples of inaccessible areas include but are not limited to (1) areas concealed by wall coverings, furniture, equipment and stored articles and (2) any portion of the structure in which inspection would necessitate removing or defacing any part of the structure(s) (including the surface appearance of the structure). **Inspection does not cover any condition or damage which was not visible in or on the structure(s) at time of inspection but which may be revealed in the course of repair or replacement work.**
- C. Due to the characteristics and behavior of various wood destroying insects, it may not always be possible to determine the presence of infestation without defacing or removing parts of the structure being inspected. Previous damage to trim, wall surface, etc., is frequently repaired prior to the inspection with putty, spackling, tape or other decorative devices. Damage that has been concealed or repaired may not be visible except by defacing the surface appearance. **The WDI inspecting company cannot guarantee or determine that work performed by a previous pest control company, as indicated by visual evidence of previous treatment, has rendered the pest(s) inactive.**
- D. If visible evidence of active or previous infestation of listed wood destroying insects is reported, it should be assumed that some degree of damage is present.
- E. If visible evidence is reported, it does not imply that damage should be repaired or replaced. Inspectors of the inspection company usually are not engineers or builders qualified to give an opinion regarding the degree of structural damage. Evaluation of damage and any corrective action should be performed by a qualified expert.
- F. **THIS IS NOT A STRUCTURAL DAMAGE REPORT OR A WARRANTY AS TO THE ABSENCE OF WOOD DESTROYING INSECTS.**
- G. If termite treatment (including pesticides, baits or other methods) has been recommended, the treating company must provide a diagram of the structure(s) inspected and proposed for treatment, label of

pesticides to be used and complete details of warranty (if any). At a minimum, the warranty must specify which areas of the structure(s) are covered by warranty, renewal options and approval by a certified applicator in the termite category. Information regarding treatment and any warranties should be provided by the party contracting for such services to any prospective buyers of the property. The inspecting company has no duty to provide such information to any person other than the contracting party.

- H. There are a variety of termite control options offered by pest control companies. These options will vary in cost, efficacy, areas treated, warranties, treatment techniques and renewal options.
- I. There are some specific guidelines as to when it is appropriate for corrective treatment to be recommended. Corrective treatment may only be recommended if (1) there is visible evidence of an active infestation in or on the structure, (2) there is visible evidence of a previous infestation with no evidence of a prior treatment.
- J. If treatment is recommended based solely on the presence of conducive conditions, a preventive treatment or correction of conducive conditions may be recommended. The buyer and seller should be aware that there may be a variety of different strategies to correct the conducive condition(s). These corrective measures can vary greatly in cost and effectiveness and may or may not require the services of a licensed pest control operator. There may be instances where the inspector will recommend correction of the conducive conditions by either mechanical alteration or cultural changes. Mechanical alteration may be in some instances the most economical method to correct conducive conditions. If this inspection report recommends any type of treatment and you have any questions about this, you may contact the inspector involved, another licensed pest control operator for a second opinion, and/or the Structural Pest Control Service of the Texas Department of Agriculture.

IV. LIMITATION OF LIABILITY

BY SIGNING THIS AGREEMENT, CLIENT (Danny & Tamra Duarte) ACKNOWLEDGES THAT THE INSPECTION FEE PAID TO THE INSPECTOR IS NOMINAL GIVEN THE RISK OF LIABILITY ASSOCIATED WITH PERFORMING HOME INSPECTIONS IF LIABILITY COULD NOT BE LIMITED. CLIENT ACKNOWLEDGES THAT WITHOUT THE ABILITY TO LIMIT LIABILITY, THE INSPECTOR WOULD BE FORCED TO CHARGE CLIENT MUCH MORE THAN THE INSPECTION FEE FOR THE INSPECTOR=S SERVICES. CLIENT ACKNOWLEDGES BEING GIVEN THE OPPORTUNITY TO HAVE THIS AGREEMENT REVIEWED BY COUNSEL OF HIS OR HER OWN CHOOSING AND FURTHER ACKNOWLEDGES THE OPPORTUNITY OF HIRING A DIFFERENT INSPECTOR TO PERFORM THE INSPECTION. BY SIGNING THIS AGREEMENT, CLIENT AGREES TO LIABILITY BEING LIMITED TO THE AMOUNT OF THE INSPECTION FEE PAID BY THE CLIENT.

INITIALED BY CLIENT: ON FILE **Fee Paid \$586.00**

V. Dispute Resolution

In the event a dispute arises regarding an inspection that has been performed under this agreement, the Client agrees to notify the Inspector in writing, within ten (10) days of the date the Client discovers the basis for the dispute so as to give the Inspector a reasonable opportunity to reinspect the property. Client agrees to allow reinspection before any corrective action is taken. Client agrees not to disturb or repair or have repaired anything which might constitute evidence relating to a complaint against the Inspector. Client further agrees that the Inspector can either conduct the reinspection himself or can employ others (at Inspector=s expense) to reinspect

the property, or both. **In the event a dispute cannot be resolved by the Client and the Inspector, the parties agree that any dispute or controversy shall be resolved by mandatory and binding arbitration. The arbitration panel must include at least one licensed home inspector.**

VI. Attorney=s Fees

The Inspector and the Client agree that in the event any dispute or controversy arises as a result of this Agreement, and the services provided hereunder, the prevailing party in that dispute shall be entitled to recover all of the prevailing party=s reasonable and necessary attorneys= fees and costs incurred by that party.

VII. Exclusivity

The Inspection Report is to be prepared exclusively for the Client named and is **not transferable to anyone** in any form. Client gives permission for the Inspector to discuss report findings with real estate agents, specialists, or repair persons for the sake of clarification. A copy of the Inspection Report may be released to the selling Real Estate Agent.

BY MY SIGNATURE BELOW, I ACKNOWLEDGE THAT I HAVE READ THIS CONTRACT AND THE ATTACHED DOCUMENTS, IF ANY; THAT I UNDERSTAND THE TERMS AND CONDITIONS AND THAT I AGREE TO BE BOUND BY THESE TERMS AND CONDITIONS. IF CLIENT IS MARRIED, CLIENT REPRESENTS THAT THIS OBLIGATION IS A FAMILY OBLIGATION INCURRED IN THE INTEREST OF THE FAMILY.

CLIENT: ON FILE
9:00 am

Danny & Tamra Duarte DATE:08/22/2022 Time

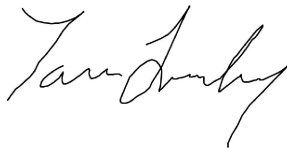

INSPECTOR:
TREC #20644
TDA/CCA #0841915
NAWT #13306ITC

Tom Langley DATE:08/22/2022 Time 9:00 am