



"A big city inspection group with small town values"



**2328 Jackson St.
Houston 77004**



PROPERTY INSPECTION REPORT FORM

Paul Homeyer <i>Name of Client</i>	03/11/2024 <i>Date of Inspection</i>
2328 Jackson St., Houston 77004 <i>Address of Inspected Property</i>	
Ruben Santillan <i>Name of Inspector</i>	5570 <i>TREC License #</i>
<i>Name of Sponsor (if applicable)</i>	<i>TREC License #</i>

PURPOSE OF INSPECTION

A real estate inspection is a visual survey of a structure and a basic performance evaluation of the systems and components of a building. It provides information regarding the general condition of a residence at the time the inspection was conducted. *It is important* that you carefully read ALL of this information. Ask the inspector to clarify any items or comments that are unclear.

RESPONSIBILITY OF THE INSPECTOR

This inspection is governed by the Texas Real Estate Commission (TREC) Standards of Practice (SOPs), which dictates the minimum requirements for a real estate inspection.

The inspector IS required to:

- use this Property Inspection Report form for the inspection;
- inspect only those components and conditions that are present, visible, and accessible at the time of the inspection;
- indicate whether each item was inspected, not inspected, or not present;
- indicate an item as Deficient (D) if a condition exists that adversely and materially affects the performance of a system or component **OR** constitutes a hazard to life, limb or property as specified by the SOPs; and
- explain the inspector’s findings in the corresponding section in the body of the report form.

The inspector IS NOT required to:

- identify all potential hazards;
- turn on decommissioned equipment, systems, utilities, or apply an open flame or light a pilot to operate any appliance;
- climb over obstacles, move furnishings or stored items;
- prioritize or emphasize the importance of one deficiency over another;
- provide follow-up services to verify that proper repairs have been made; or
- inspect system or component listed under the optional section of the SOPs (22 TAC 535.233).

RESPONSIBILITY OF THE CLIENT

While items identified as Deficient (D) in an inspection report DO NOT obligate any party to make repairs or take other actions, in the event that any further evaluations are needed, it is the responsibility of the client to obtain further evaluations and/or cost estimates from qualified service professionals regarding any items reported as Deficient (D). It is recommended that any further evaluations and/or cost estimates take place prior to the expiration of any contractual time limitations, such as option periods.

Please Note: Evaluations performed by service professionals in response to items reported as Deficient (D) on the report may lead to the discovery of additional deficiencies that were not present, visible, or accessible at the time of the inspection. Any repairs made after the date of the inspection may render information contained in this report obsolete or invalid.

REPORT LIMITATIONS

This report is provided for the benefit of the named client and is based on observations made by the named inspector on the date the inspection was performed (indicated above).

ONLY those items specifically noted as being inspected on the report were inspected.

This inspection IS NOT:

- a technically exhaustive inspection of the structure, its systems, or its components and may not reveal all deficiencies;
- an inspection to verify compliance with any building codes;
- an inspection to verify compliance with manufacturer’s installation instructions for any system or component and DOES NOT imply insurability or warrantability of the structure or its components.

NOTICE CONCERNING HAZARDOUS CONDITIONS, DEFICIENCIES, AND CONTRACTUAL AGREEMENTS

Conditions may be present in your home that did not violate building codes or common practices in effect when the home was constructed but are considered hazardous by today's standards. Such conditions that were part of the home prior to the adoption of any current codes prohibiting them may not be required to be updated to meet current code requirements. However, if it can be reasonably determined that they are present at the time of the inspection, the potential for injury or property loss from these conditions is significant enough to require inspectors to report them as Deficient (D). Examples of such hazardous conditions include:

- malfunctioning, improperly installed or missing ground fault circuit protection (GFCI) devices and arc-fault devices;
- ordinary glass in locations where modern construction techniques call for safety glass;
- malfunctioning or lack of fire safety features such as, smoke alarms, fire-rated doors in certain locations, and functional emergency escape and rescue openings in bedrooms;
- malfunctioning carbon monoxide alarms;
- excessive spacing between balusters on stairways and porches;
- improperly installed appliances;
- improperly installed or defective safety devices;
- lack of electrical bonding and grounding; and
- lack of bonding on gas piping, including corrugated stainless steel tubing (CSST).

Please Note: items identified as Deficient (D) in an inspection report DO NOT obligate any party to make repairs or take other actions. The decision to correct a hazard or any deficiency identified in an inspection report is left up to the parties to the contract for the sale or purchase of the home.

This property inspection report may include an inspection agreement (contract), addenda, and other information related to property conditions.

INFORMATION INCLUDED UNDER "ADDITIONAL INFORMATION PROVIDED BY INSPECTOR", OR PROVIDED AS AN ATTACHMENT WITH THE STANDARD FORM, IS NOT REQUIRED BY THE COMMISSION AND MAY CONTAIN CONTRACTUAL TERMS BETWEEN THE INSPECTOR AND YOU, AS THE CLIENT. THE COMMISSION DOES NOT REGULATE CONTRACTUAL TERMS BETWEEN PARTIES. IF YOU DO NOT UNDERSTAND THE EFFECT OF ANY CONTRACTUAL TERM CONTAINED IN THIS SECTION OR ANY ATTACHMENTS, CONSULT AN ATTORNEY.

ADDITIONAL INFORMATION PROVIDED BY INSPECTOR

How to read and interpret this report:

All commented items should be repaired or addressed to client's satisfaction PRIOR TO THE EXPIRATION OF YOUR OPTION PERIOD.

Highest Priority Items are printed in bold print and/or are in boxes

Items that are underlined should be addressed to prevent more extensive damage and should be a priority item or indicate non-compliance with current building standards.

Comments in italics are generally FYI (for your information) and don't require any action.

For reference: The front of the unit faces south

Description: 3 story, wood framed single family residence ; cement board exterior; composition roof; attached garage

I=Inspected

NI=Not Inspected

NP=Not Present

D=Deficient

I NI NP D

I. STRUCTURAL SYSTEMS

-

A. Foundations

Type of Foundation(s): Slab on grade

Comments:

A foundation elevation survey was conducted during the inspection. The table below represents data gathered using a Zip Level or similar instrument and adjusting for floor covering height differences. i.e. differences between tile, carpet and wood flooring. Measurements are listed to the nearest .1". Measurements were taken along the respective walls listed below-North, East South, West, etc. Greatest variance was 0.1 of an inch for the 1st floor and 1.1 inch variance for the 2nd floor



I=Inspected

NI=Not Inspected

NP=Not Present

D=Deficient

I NI NP D

Differential movement / settlement observed; indicated by one or more of the following observed conditions; Cracks in brick veneer and/or foundation, Cracks in sheetrock over doors and windows, doors that are not square in jamb, etc. In my opinion the distress patterns observed at the time of inspection are/were not severe enough to recommend repair. Acceptance of present and future condition / performance / maintenance rests solely with the buyer / client.

B. Grading and Drainage

Comments:

No deficiencies observed at the time of inspection.

C. Roof Covering Materials

Types of Roof Covering: composition shingles over solid decking

Viewed From: with drone

Comments:

ROOF SURFACE:

Observed spot repairs to roof surface.



Area(s) of soft/spongy and/or rotted roof decking observed while walking on roof. (northwest, central west edge, and south center over the master bedroom)



I=Inspected

NI=Not Inspected

NP=Not Present

D=Deficient

I NI NP D



ROOF PENETRATIONS:
(see furnace vent section)

EVIDENCE OF ROOF WATER PENETRATION:

Roof water penetration observed at the following location(s): evidence of water intrusion observed at 3 different locations in the attic. See pictures above. This condition should be further evaluated by a qualified roofing company.

RAIN GUTTERS AND DOWNSPOUTS:
No deficiencies observed at the time of inspection.

-

D. Roof Structures and Attics

Viewed From: Safely accessible areas as deemed by the inspector
Approximate Average Depth of Insulation: 10-12 inches
Approximate Average Thickness of Vertical Insulation: not observable
Comments:

ROOF STRUCTURE AND FRAMING:
No deficiencies observed at the time of inspection.

ATTIC INSULATION:
No deficiencies observed at the time of inspection.

I=Inspected

NI=Not Inspected

NP=Not Present

D=Deficient

I NI NP D

ATTIC ACCESS, LADDERS AND SERVICE WALKS:

Not all areas of attic were accessible for inspection.

No deficiencies observed at the time of inspection.

ATTIC VENTILATION AND SCREENING:

No deficiencies observed at the time of inspection.

E. Walls (Interior and Exterior)

Comments:

Houses built prior to 1978 may contain lead based paint, this company does not inspect for lead, bio-hazards or any other pollutants.

Client Advisory: No moisture, mold and /or indoor air quality (IAQ) tests were performed. The inspector is not qualified / certified for such evaluations / studies. The client should be aware that various fungi, molds and mildew flourish in such an environment provided by water intrusion events, excessively moist conditions and / or water damaged conditions. A growing concern to date includes the adverse effect on indoor air quality and the potential for inherent health hazards. If concerned the client is advised to contact a qualified IAQ Professional for further evaluations of this property.

EXTERIOR:

Recommend additional stucco intrusive inspection be conducted to rule out the possibility of unseen / undetected / latent / hidden water damage behind areas of the stucco exterior. Sections of the exterior appear to be traditional hard coat / cement-based stucco. A limited visual inspection by this inspector has created concerns regarding the possibility of latent damage from water penetration behind the stucco at one of more locations that can only be verified by drilling / intrusive testing. Recommend client contact our office or another third party stucco inspector of your choice prior to the expiration of any option period to conduct an intrusive stucco inspection.



I=Inspected

NI=Not Inspected

NP=Not Present

D=Deficient

I	NI	NP	D
---	----	----	---

Need sealing / caulking around all holes and exterior siding penetrations on top and both sides, (leave bottom open) to prevent water entry. Including but not limited to dryer, bath and range top vents, light fixtures, etc.

Recommend general maintenance, painting, sealing, or repairing wood deterioration to help prevent possible water intrusion.



Wood rot observed on areas of house / garage. (window trim pieces, garage door trim, patio decking fascia etc)



I=Inspected

NI=Not Inspected

NP=Not Present

D=Deficient

I	NI	NP	D
---	----	----	---



Caulking missing and/or deficient at vertical joints in siding; may allow wind driven rain entry.

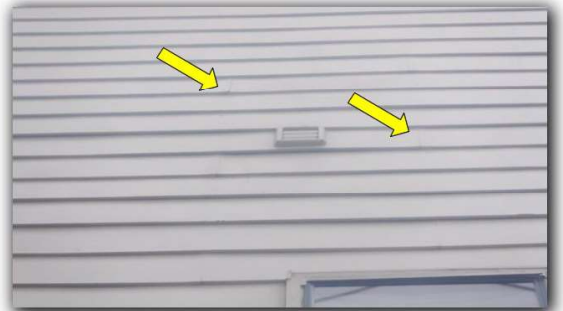
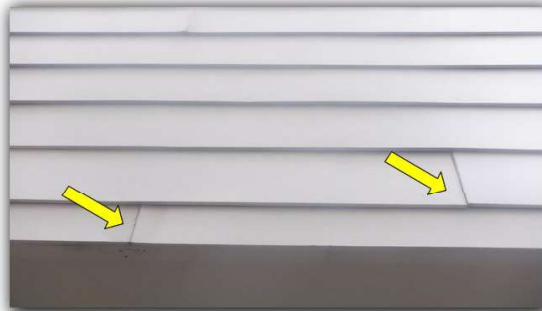

Caulking missing and/or deficient around vertical trim boards may allow wind driven rain entry.

Bushes / trees / foliage should not contact siding of house to prevent wood rot and/or insect access.

Fascia board observed to be pulling loose at the gutter on the northwest corner of the structure.

I=Inspected

NI=Not Inspected

NP=Not Present

D=Deficient

I NI NP D

Did not observe weep screed at bottom of the stucco wall, where it intersects with the soffit. The following diagram depicts a “best practice” procedure as defined in the Texas Lathing and Plastering Contractor's Association (TLPCA) Stucco Resource Guide. This detail provide a means for moisture to exit from behind the stucco if the wall assembly leaks (we seldom see a weep screed at these locations on most stucco homes / buildings). If this exhibits a problem with moisture collecting in this area, a weep screed should be installed.

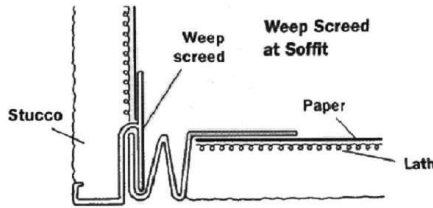

A section of small trim at the 2nd floor patio observed to be missing.



EVIDENCE OF WATER PENETRATION:

Water penetration observed at the following location(s):evidence of water penetration observed adjacent to the sliding door in the living room. Low moisture meter readings were taken at the time of this inspection.



I=Inspected

NI=Not Inspected

NP=Not Present

D=Deficient

I	NI	NP	D
---	----	----	---

Possible water intrusion repairs observed on the staircase window between the 2nd and 3rd floor. Low moisture meter readings were taken at the time of this inspection.

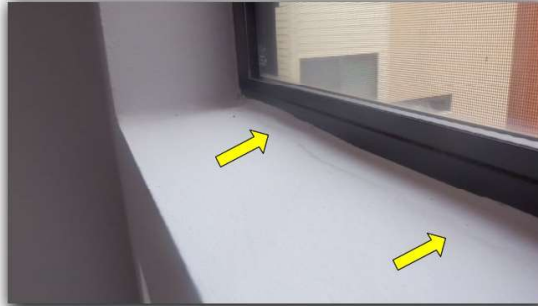

-
-
-
-

F. Ceilings and Floors

Comments:

CEILINGS:

Evidence of painting and patching observed at one or more locations.

Thermal imaging of the interior was taken and no anomalies were observed.

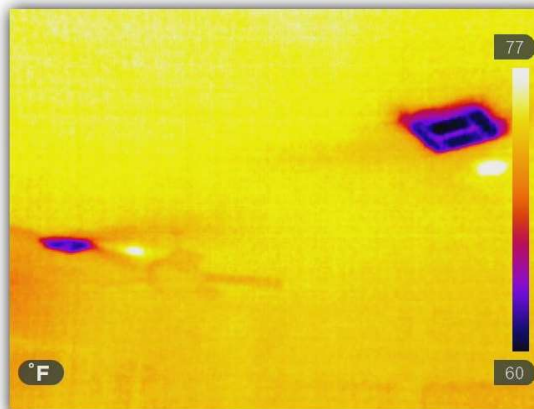
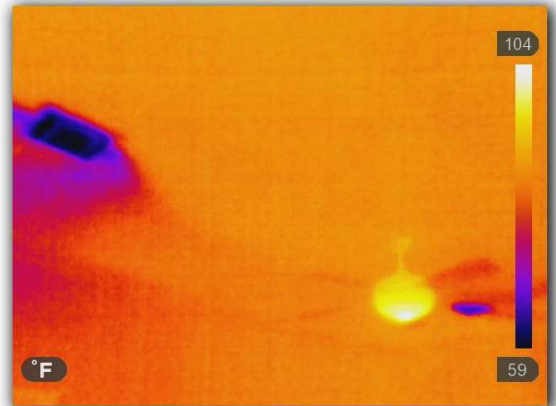
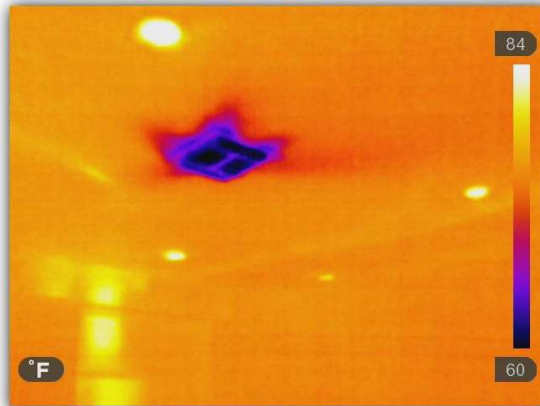

I=Inspected

NI=Not Inspected

NP=Not Present

D=Deficient

I	NI	NP	D
---	----	----	---

FLOORS:

No deficiencies observed at the time of inspection.

G. Doors (Interior and Exterior)

Comments:

INTERIOR:

Second floor half bathroom door observed to be out of balance and will swing open without being touched.

One or more doors in house will not latch. (master closet door)

EXTERIOR:

Prudent buyers replace/rekey exterior locks upon taking possession of property.
No deficiencies observed at the time of inspection.

GARAGE:

No deficiencies observed at the time of inspection.

H. Windows

Comments:

WINDOWS:

Windows at one or more 2nd floor rooms were a potential fall hazard for small children due to their low height above the floor; did not observe fall protection outside the window. Ref IRC R613.2 Window Sills: In dwelling units, where the opening of an operable window is located more than 72 inches above finished grade or surface below, the lowest part of the clear opening of the window shall be a minimum of 24 inches above the finished floor of the room in which the window is located. Glazing between the floor and 24 inches shall be fixed or have openings through which a 4-inch diameter sphere cannot pass.

I=Inspected

NI=Not Inspected

NP=Not Present

D=Deficient

I NI NP D

One or more window spring(s) were observed to be sprung/broken/detached. **(1st floor landing)**

Window jamb alarm sensors need to be sealed with silicone seal to prevent water entry.(1st floor landing)



Master bedroom window, 3rd floor back bedroom, and living area windows are difficult to operate, the windows will not slide smoothly on their tracks.

One or more of the thermal pane windows observed to have lost their seals. This has resulted in condensation and/or a fog like film to develop between the panes of glass. The thermal pane windows no longer function as designed when they loose their seals. The windows that have noticeably lost their seals are listed but may not be limited to the following: **living room 4, staircase between the 1st and 2nd floor 1, 3rd floor landing 1, master bedroom 1,**

Special Notice: Signs of lost seals in the thermal pane windows may appear and disappear as temperature and humidity change. **Some windows with lost seals may not be evident at the time of this inspection.** Windows are only checked for obvious fogging. If some lost thermal pane window seals were noted, we recommend all windows be rechecked by a window specialist for further evaluation.



SAFETY GLASS IN HAZARDOUS LOCATIONS:

No deficiencies observed at the time of inspection.

I=Inspected

NI=Not Inspected

NP=Not Present

D=Deficient

I	NI	NP	D
---	----	----	---

I. Stairways (Interior and Exterior)

Comments:

INTERIOR:

No deficiencies observed at the time of inspection.

J. Fireplaces and Chimneys

Comments:

Not present at time of inspection.

K. Porches, Balconies, Decks, and Carports

Comments:

Cracks in walkways, driveway and/or garage concrete observed, typical.

Balcony floor boards observed to be pulling loose, poor condition, and deteriorated. One or fasteners also observed to be pulling loose.



I=Inspected

NI=Not Inspected

NP=Not Present

D=Deficient

I	NI	NP	D
---	----	----	---

Perimeter fascia at both of the balconies observed to be in poor condition, loose and improperly fastened.



L. Other

Comments:

I=Inspected

NI=Not Inspected

NP=Not Present

D=Deficient

I NI NP D

II. ELECTRICAL SYSTEMS

A. Service Entrance and Panels

Comments:

150 AMP ELECTRICAL SERVICE PANEL LOCATED AT NORTH EXTERIOR

Code requires minimum clearance to electrical service panels to be 36" in front of and 30" from side to side.

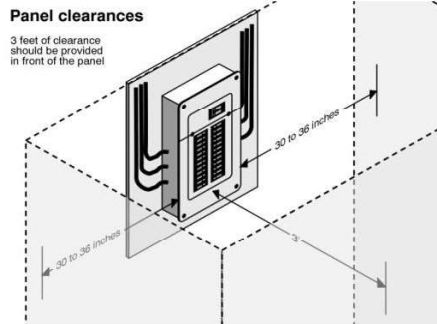

I=Inspected

NI=Not Inspected

NP=Not Present

D=Deficient

I	NI	NP	D
---	----	----	---

Did not observe anti-oxidant compound (grease) on the exposed aluminum feeder wiring OR the gel was not adequate.

The ground electrode is not driven the proper depth into the ground. Most of the 8 foot rod should be embedded in the earth with the exception of the clamp connection at the top. The electrode was not pulled up but feels loose, may not be the required 8 feet in length.

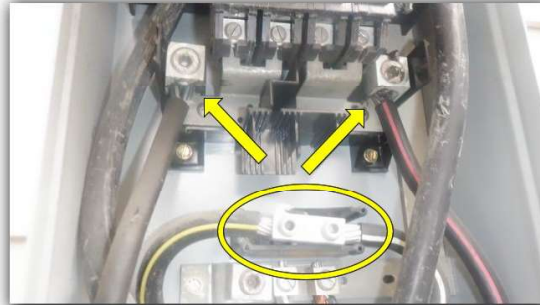

150 AMP ELECTRICAL SUB PANEL LOCATED AT GARAGE



I=Inspected

NI=Not Inspected

NP=Not Present

D=Deficient

I NI NP D

Observed improper use of normal wire conductor colors. Observed black wire used for other than ungrounded / hot conductors, white wire used for other than grounded / neutral, and/or bare green wire use for other than grounding conductors.

Improper connection at sub-panel, need to remove bonding jumper from ground bus bar to isolate ground from neutral.

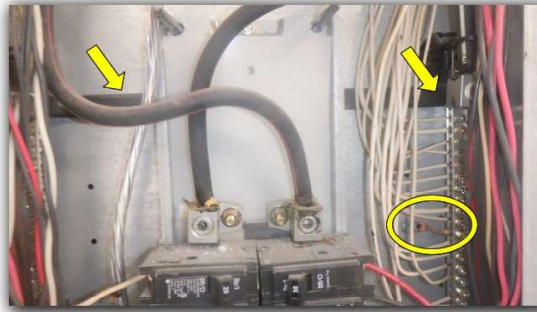

Observed AFCI (Arc Fault Circuit Interrupt) device protection on electrical circuits, most probably protecting the bedroom circuits. AFCI devices are intended to protect against fires caused by electrical arcing faults in the home's wiring. Arc faults are a common cause of residential electrical fires. Arc faults can be created by damaged, deteriorated, or worn electrical plugs, cords, and/or branch circuit conductors.

We generally do not test / operate the AFCI (Arc Fault Circuit Interrupt) devices when the home is occupied. Testing these devices causes a sudden loss of power which can detrimentally affect electronic and computing equipment that has not first been powered down safely. We recommend that our clients have these devices tested (simply by pushing the test button on the breaker in the electrical service panel) once the home is vacant or electronic equipment has been powered down.

Be advised As of September 1, 2008, the State of Texas has adopted the 2005 NEC, which includes this requirement, as the "minimum standard" for all non-exempt electrical work. Homes built between 2002 and late 2008, generally were only required to have arc fault protection for bedroom circuits. However, the current / recently adopted TREC standards of practice requires licensed home inspectors to indicate that a deficient condition exists in any home (as if the home were built today, regardless of date the home was constructed) does not have this protection at all locations required by the most current version of the National Electric Code "NEC" (currently bedrooms, family rooms, dining rooms, living rooms, parlors, libraries, dens, bedrooms, sunrooms, recreations rooms, closets, hallways, or similar rooms or areas).

I=Inspected

NI=Not Inspected

NP=Not Present

D=Deficient

I	NI	NP	D
---	----	----	---

SERVICE WIRING:

Observed service type of wiring is aluminum.

FEEDER WIRING:

Observed type of feeder wiring is aluminum.

B. Branch Circuits, Connected Devices, and Fixtures

Type of Wiring: Observed type of branch wiring is copper.

Comments:

BRANCH WIRING:

Open junctions observed on the ceiling fixtures in the garage and master closet area.

Recommend installing proper covers to prevent possible arcing or sparks from falling onto one self/ground.

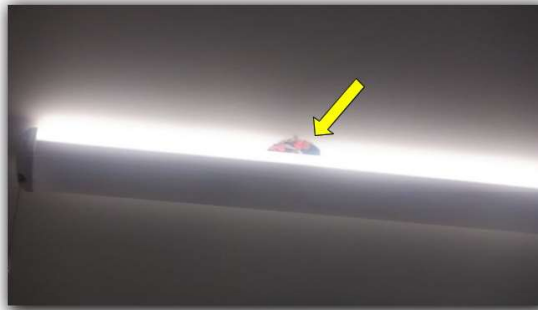

FIXTURES:

Ceiling fan(s) not balanced and/or noisy operation, living room unit, and 3rd floor back bedroom.

OUTLETS:

Outlets located in inaccessible areas (e.g., garage ceilings, exterior soffits, etc.) are not individually tested.

*GFCI reset locations; kitchen 2, garage 1, master bathroom 2,
One or more outlets are not secured well in wall. (laundry room)*

I=Inspected

NI=Not Inspected

NP=Not Present

D=Deficient

I NI NP D

SWITCHES:

Random sampling showed switch(s) are not grounded as required by current industry standards / code; 1999 NEC 380-9(b) “Provisions for snap switch faceplates; Snap switches, including dimmer switches, shall be effectively grounded and provide a means to ground metal face-plates, whether or not a metal face-plate is installed.” Recommend grounding of all switches with ground lug.(master bedroom and 3rd floor landing only) Ground wires are connected to the switches, however a ground fault still exist. The cause and remedy should be investigated and corrected as necessary.

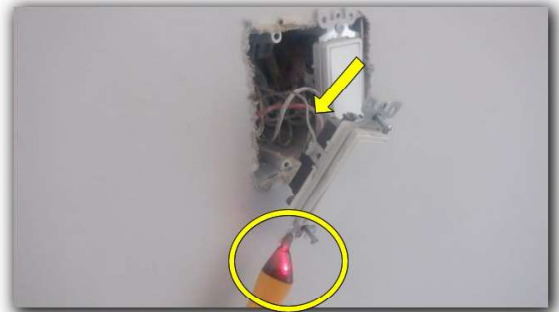

EQUIPMENT DISCONNECTS:

Code requires minimum clearance to electrical service panels (including A/C disconnects) to be 36” in front of and 30” from side to side.

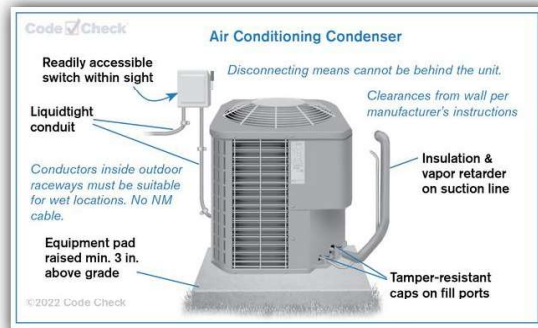

I=Inspected

NI=Not Inspected

NP=Not Present

D=Deficient

I	NI	NP	D
---	----	----	---

SMOKE DETECTORS AND ALARMS:

Smoke detectors are tested using the manufacturer supplied test button only. This inspection does not include testing units with actual smoke.

The installation of smoke alarm(s) is required inside of all bedrooms and in any rooms designated for the purpose of sleeping, and outside within the proximity of the doors to those rooms. Test all alarms and detectors weekly or monthly per manufacture instructions. The installation of carbon monoxide (CO) detector(s) is required in homes with fuel-fired appliances at every floor elevation and any areas where fuel-fired equipment is located. The installation of Type ABC fire extinguisher(s) at the kitchen, laundry, and garage, if applicable, is also advised. Test all of these devices monthly. Install new batteries semi-annually. Initiate and practice plans of escape and protection for all occupants in case any emergencies arise. Failure to repair defective or install absent alarms, detectors, and other safety equipment immediately can result in serious injury or death. For further information about fire safety and CO poisoning, consult your local fire department and your equipment manufacture(s), and read these links: www.cpsc.gov/CPSCPUB/PUBS/464.pdf, www.carbonmonoxidekills.com, www.nfpa.org/index.asp, and www.usfa.dhs.gov/downloads/pyfff/inhome.html.

DOORBELL & CHIMES

Unit was not operational, not performing its intended function, in need of repair/replacement.

C. Other

Comments:

I=Inspected

NI=Not Inspected

NP=Not Present

D=Deficient

I	NI	NP	D
---	----	----	---

III. HEATING, VENTILATION AND AIR CONDITIONING SYSTEMS

A. Heating Equipment

Type of Systems: Forced air

Energy Sources: Gas

Comments:

1ST AND 2ND FLOOR HEATING UNIT: FUNCTIONING

Make: Lennox-2006 unit

Model: G40UH-36A-070-15

S/N: 5906M07974

3RD FLOOR HEATING UNIT: FUNCTIONING

Make: Carrier-2022 unit

Model: 58SB0A070E171112

S/N: 0822A18317



I=Inspected

NI=Not Inspected

NP=Not Present

D=Deficient

I NI NP D

HOUSE HEATER EXHAUST VENT(S):

The 3rd floor unit vent is not properly connected at the vent connection inside the furnace cabinet. Fasteners observed to be missing, exposing a gap at the base. This may allow harmful gases to vent into the attic.



Improperly vented, does not extend high enough above roof. Vent pipe is required to extend and terminate at least 24 inches above roof line to the lowest discharge opening of the vent cap. (Ref: IRC 2004 Section 2427.6.5 Gas Vent Termination) (1st and 2nd floor unit)

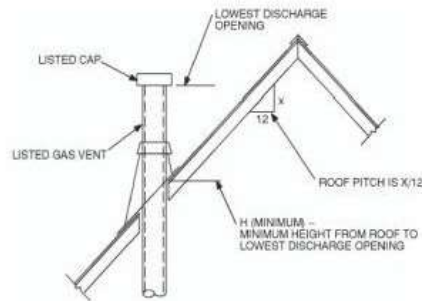

BLOWER(S):

No deficiencies observed at the time of inspection.

THERMOSTAT(S):

Thermostat wiring not secured to attic unit(s), missing small fitting that secures wiring to cabinet to prevent pulling loose by service personnel or homeowner.



I=Inspected

NI=Not Inspected

NP=Not Present

D=Deficient

I NI NP D

B. Cooling Equipment

Type of Systems: Forced air-split system

Comments:

Buyers note; when 2 A/C units are located closer than 3 feet from each other it can adversely affect the efficiency of both units.

Cool outside ambient temperature prevented operation of A/C under typical Houston summer conditions. Client is advised unit was operated under light heat load conditions. IE: A unit that cools well on a cool day may not perform adequately during a hot Houston summer.

1ST AND 2ND FLOOR CONDENSING UNIT:

Make: Lennox-2007 unit

Model: 13ACD-030-230-02

S/N: 5807A55626

Unit has exceeded its normal serviceable life span; replacement should be expected and budgeted for in near future.

Unit not level, needs to be level for proper operation.

1ST AND 2ND FLOOR EVAPORATOR COIL:

Temperature Differential: 68.0-48.2=19.8

Make: Trane-2012 unit

Capacity: 3 ton

3RD FLOOR CONDENSING UNIT:

Make: Carrier-2022 unit

Model: CA16NA036-B

S/N: 1222X61198

Unit not level, needs to be level for proper operation.

3RD FLOOR EVAPORATOR COIL:

Temperature Differential: 64.8-45.1=19.7

Make: Carrier-2022 unit

Capacity: 3 ton

I=Inspected

NI=Not Inspected

NP=Not Present

D=Deficient

I NI NP D

CONDENSATION DRAIN PAN/DRAIN LINES:

Secondary drain pan is very rusted, recommend replacement.(both units)



C. Duct Systems, Chases, and Vents

Comments:

Observed several / multiple areas in attic where flex duct touch and are missing required 1" clearance from other ducts to prevent condensation between ducts that touch. Recommend general maintenance to flex ducts in attic, Re-support where needed, seal/tape minor air leaks, repair torn/damaged vapor seal, etc.



Some flex duct observed to be improperly routed with sharp bends and / or excess material in bends. Improper routing increases frictional loss in the duct and reduces heating and cooling efficiency. Radius at centerline of the bend should be no less than the diameter of the duct.

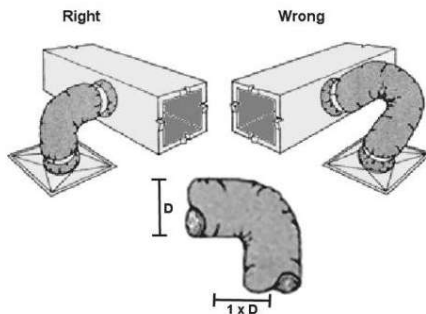

I=Inspected

NI=Not Inspected

NP=Not Present

D=Deficient

I	NI	NP	D
---	----	----	---



Excessive air loss at evaporator coil around drain and Freon line connections.(1st and 2nd floor unit)



-
-
-
-

D. Other

Comments:

I=Inspected

NI=Not Inspected

NP=Not Present

D=Deficient

I NI NP D

IV. PLUMBING SYSTEMS

A. Plumbing Supply, Distribution Systems and Fixtures

Location of water meter: Front of property

Location of main water supply valve: north exterior wall of house

Static water pressure reading:

Type of supply piping material: Water supply piping observed to be predominantly PEX (cross-linked polyethylene) plastic.



Comments:

WATER SUPPLY PLUMBING:

Water softener, treatment and filtration type of equipment was not checked/inspected.

COMMODES:

No deficiencies observed at the time of inspection.

SINKS:

FAUCETS:

The master shower faucet handle was stiff and difficult to operate.

I=Inspected

NI=Not Inspected

NP=Not Present

D=Deficient

I	NI	NP	D
---	----	----	---

TUBS:

Grout / caulking needed at vertical tile corners, cracks in tile and/or mortar between tiles, and where tile meets tub to prevent water entry behind wall. (1st floor bath)



SHOWER(S):

24 hour shower pan test has been specifically excluded.

One or more shower head(s) leak water. **(1st floor bath)**

Shower diverter valve is not fully functional, does not direct all water to shower head during operation, 3rd floor back bathroom.

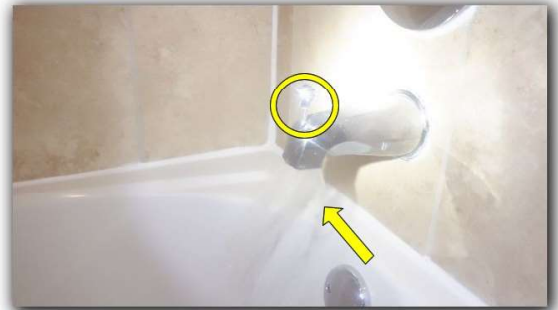

Master shower head should be cleaned or replaced as necessary, not spraying water out of the shower head ports evenly.

LAUNDRY CONNECTIONS:

Recommend use of stainless steel braided "no burst" clothes washer water supply lines to reduce chance of water damage.

EXTERIOR HOSE BIBS:

No deficiencies observed at the time of inspection.

GAS SUPPLY SYSTEMS

Pressure test of gas lines has been specifically excluded.

Gas meter located at the north exterior side of house

I=Inspected

NI=Not Inspected

NP=Not Present

D=Deficient

I NI NP D

OBSERVED BRANCH LINES:

Galvanized and/or black iron

APPLIANCE CONNECTIONS:

Proper flex

Close proximity to gas meter is potential hazard and NEC code violation.

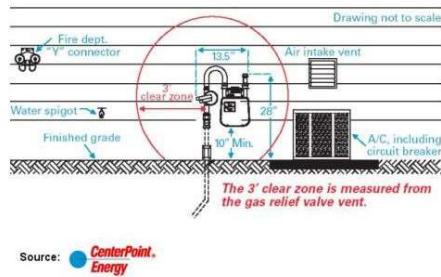

-
-
-
-

B. Drains, Wastes, and Vents

Type of drain piping material: Water supply piping observed to be predominantly plastic.

Comments:

Hydrostatic pressure test of sewer lines was specifically excluded.

DRAIN, WASTE, VENT PLUMBING:

Type of drain waste vent material observed to primarily plastic

There were no plumbing access / inspection panels behind one or more tub(s). Overflow gaskets and drains not checked. Recommend installation of bath plumbing access panels where possible.

I=Inspected

NI=Not Inspected

NP=Not Present

D=Deficient

I	NI	NP	D
---	----	----	---

-
-
-
-

C. Water Heating Equipment

Energy Source: Gas-2006 unit

Capacity: 50 gallons

Comments:

WATER HEATING UNIT(S):

Unit has exceeded its normal serviceable life; budget for repair or replacement.

The water heater was set too close to the water heater emergency pan drain blocking the pipe opening.



WATER HEATER EXHAUST VENT(S):

No deficiencies observed at the time of inspection.

TEMPERATURE AND PRESSURE RELIEF VALVE(S):

Did not check operation since valve(s) is/are over 3 years old. Most manufacturers recommend replacement of T&P valves over 3 years of age.

Drain line terminates improperly, current industry standards (Code) require drain line terminate within 6 inches from grade. Recognized safety hazard, repair IRC 2803.6.1.



I=Inspected

NI=Not Inspected

NP=Not Present

D=Deficient

I NI NP D

D. Hydro-Massage Therapy Equipment

Comments:

Was not able to access motor for visual inspection. Does not fully comply with National Electric Code (Reference NEC 680-72. Accessibility. "hydromassage bathtub electrical equipment shall be accessible for repair / replacement without damaging the building structure or building finish".) Should have access panel installed for servicing / access to pump motor IRC 4109.3.



E. Gas Distribution Systems and Gas Appliances

Location of gas meter:

Type of gas distribution piping material:

Comments:

F. Other

Comments:

V. APPLIANCES

A. Dishwashers

Comments:

Rust observed on interior of cabinet and/or dish racks.

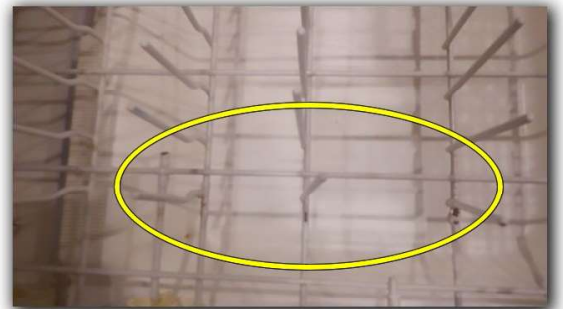

B. Food Waste Disposers

Comments:

No deficiencies observed at the time of inspection.

I=Inspected

NI=Not Inspected

NP=Not Present

D=Deficient

I	NI	NP	D
---	----	----	---

C. Range Hood and Exhaust Systems

Comments:

No deficiencies observed at the time of inspection.

D. Ranges, Cooktops, and Ovens

Comments:

GAS RANGE/COOKTOP:

No deficiencies observed at the time of inspection.

ELECTRIC OVEN:

Timer and cleaning cycles not checked

No deficiencies observed at the time of inspection.

E. Microwave Ovens

Comments:

No deficiencies observed at the time of inspection.

F. Mechanical Exhaust Vents and Bathroom Heaters

Comments:

Improperly vents to soffit. Should vent to exterior.

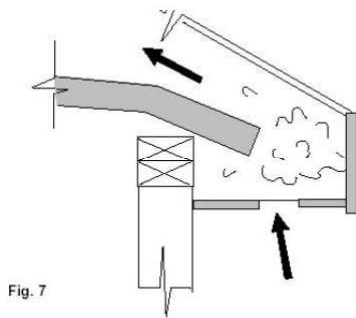

Fig. 7

Terminating exhaust fans to soffits/eaves builds up condensation moisture within the soffit that can deteriorate the fascia board, soffit and/or plywood roof decking and cause paint peeling. A soffit/eave is part of attic air space where exterior air is drafted in to the attic space with the exhaust duct fumes and moisture.



I=Inspected

NI=Not Inspected

NP=Not Present

D=Deficient

I NI NP D

-

G. Garage Door Operators

Comments:

Remote control hand held units were not checked/inspected.

Missing required safety sticker / decal next to operator button.



-

H. Dryer Exhaust Systems

Comments:

Recommend periodic cleaning of the dryer vent ductwork to reduce the risk of fire.

-

I. Other

Comments:

VI. OPTIONAL SYSTEMS

-

A. Outdoor Cooking Equipment

Energy Source:

Comments:

-

B. Landscape Irrigation (Sprinkler) Systems

Comments:

Not present at time of inspection.

I=Inspected

NI=Not Inspected

NP=Not Present

D=Deficient

I	NI	NP	D
---	----	----	---

<input type="checkbox"/>	<input checked="" type="checkbox"/>	<input checked="" type="checkbox"/>	<input type="checkbox"/>
--------------------------	-------------------------------------	-------------------------------------	--------------------------

C. Swimming Pools, Spas, Hot Tubs, and Equipment

Type of Construction:

Comments:

<input type="checkbox"/>	<input checked="" type="checkbox"/>	<input checked="" type="checkbox"/>	<input type="checkbox"/>
--------------------------	-------------------------------------	-------------------------------------	--------------------------

D. Outbuildings

Comments:

Not present at time of inspection.

<input type="checkbox"/>	<input checked="" type="checkbox"/>	<input checked="" type="checkbox"/>	<input type="checkbox"/>
--------------------------	-------------------------------------	-------------------------------------	--------------------------

E. Private Water Wells (A coliform analysis is recommended)

Type of Pump:

Type of Storage Equipment:

Comments:

<input type="checkbox"/>	<input checked="" type="checkbox"/>	<input checked="" type="checkbox"/>	<input type="checkbox"/>
--------------------------	-------------------------------------	-------------------------------------	--------------------------

F. Private Sewage Disposal Systems

Type of System:

Location of Drain Field:

Comments:

<input type="checkbox"/>	<input checked="" type="checkbox"/>	<input type="checkbox"/>	<input type="checkbox"/>
--------------------------	-------------------------------------	--------------------------	--------------------------

G. Other Built-in Appliances

Comments:

<input type="checkbox"/>	<input checked="" type="checkbox"/>	<input checked="" type="checkbox"/>	<input type="checkbox"/>
--------------------------	-------------------------------------	-------------------------------------	--------------------------

H. Other

Comments:

INTENT OF INSPECTION:

It is the expressed intent and purpose of this report to inform you the client exclusively of the **visual ("eyeball") observations** and opinions made on the day of the inspection as to whether or not the structure, electrical, plumbing, and mechanical components of the subject property are performing the function for which they were intended to perform or are in need of immediate repairs. It is not within the intent and/or scope of this report to determine the insurability, habitability, suitability of use, economic life span, deferred maintenance issues, and/or issues unnamed in this report. **This report is neither an expressed nor implied warranty and / or guarantee as to future life and/or performance of the items inspected**, but is intended to express the inspector's perceived impression of the apparent performance of the structure, electrical, plumbing, and mechanical components viewed on the date of the inspection. **Our intent is to reduce your risk associated with this transaction, however we cannot eliminate all risk nor assume your risk.**

SCOPE OF INSPECTION:

The content of this report is based solely upon "eyeball" observations of apparent performance. Opinions have been formed from the inspector's personal knowledge and experience and not upon any code requirements and/or performance standards. Compliance with any federal, state or local codes and/or other legal requirements is not within the scope or intent of this report.

METHOD OF INSPECTION:

The inspection methodology has not been of a formal engineered type of inspection; therefore, no soil, physical or geological testing or inspections were performed. Many of the structural, electrical, plumbing, and mechanical components were judged indirectly by the visible condition of the surfaces and/or components open to view. Observations were made both inside as well as outside of the structure; however, these observations were limited to only those areas open to view without moving any item, i.e.; inhabitants furniture, belongings or stored items which was blocking the view. The inspector did not employ any instruments to aid in the inspection, **disassemble any component of an item checked**, (i.e.: disassemble a heating unit to inspect for a cracked heat exchanger), conduct extensive destructive testing, calculations, or removal of wall and floor covering unless noted in the body of this report.

LIMITATION OF INSPECTION:

The visual inspection method employed will generally produce a competent first impression assessment of the apparent past structural, electrical, plumbing, and mechanical components, provided refurbishing repairs have not been performed which would mask distress patterns normally produce by structural, electrical, plumbing, and mechanical components problems.

Because the inspection procedure is visual only and was not intended to be diagnostic and/or technically exhaustive, an inherent residual risk remains that undiscovered problems exist and/or future problems will develop.

There is no guarantee or warranty stated or implied that all defects have been found or that Sentinel Inspection Group, LLC will pay for the repair of any defect not discovered. The content of this report should be considered as an opinion of apparent performance of the items inspected and not engineering fact. **THIS INSPECTION DOES NOT INCLUDE THE INSPECTION OF, SAMPLING FOR OR TESTING OF ANY SUBSTANCE CLASSIFIED OR OTHERWISE IDENTIFIED WITH OR AS A TOXIC SUBSTANCE AND/OR BIO-HAZARD OR WOOD DESTROYING INSECTS/ORGANISMS.**

Client Advisory: No moisture, mold and /or indoor air quality (IAQ) tests were performed, The inspector is not qualified / certified for such evaluations / studies. The client should be aware that various fungi, molds and mildew flourish in such an environment provided by water intrusion events, excessively moist conditions and /or water damaged conditions. A growing concern to date includes the adverse effect on indoor air quality and the potential for inherent health hazards. If concerned the client is advised to contact a qualified IAQ Professional for further evaluations of this property.

EXPERT TESTIMONY / LITIGATION FINANCIAL COMPENSATION CLAUSE:

In the event our services are needed at any time in the future as expert testimony or in a litigation case, client agrees at this time / in advance to financially compensate this firm for it's time and services.

Terms: Non-refundable retainer of \$2,500.00 upfront, Hourly rate of \$175.00 for any activities on our part for your case, including but not limited to; deposition, phone time, research, court time, travel time portal to portal, review of case prior to court appearance, etc. Balance due invoiced weekly, submitted Wednesday, payable the next Friday

ARBITRATION / DISPUTE RESOLUTION

In the event a dispute arises regarding an inspection that has been performed under this service agreement, Client(s) agree to notify Sentinel Inspection Group, LLC within ten (10) days of the time of discovery to give Walters Home Inspection a reasonable opportunity to re-inspect the property and resolve the dispute amicably. Upon the request of either party, all unresolved disputes relating to this agreement shall be submitted for arbitration in accordance

with (AAA) American Association of Arbitrators then in effect with costs shared equally. This provision shall be specifically enforceable and damages for breach of this provision shall include but not limited to court costs and attorney's fees. Client agrees that Sentinel Inspection Group, LLC and it's agents liability, if any, shall be limited to the amount of the inspection fee paid for inspection. This limitation shall apply regardless of the cause of action or the legal theory pled or asserted specifically including, but not limited to, negligence. Sentinel Inspection Group, LLC

Sentinel Inspection Group, LLC does not conduct re-inspection services for any reason. We are not in the business of certifying workmanship and/or warranting another company's repair work. Receipts and/or warranty for work performed should be obtained from the company or companies who have provided repairs.

Acceptance and/or reliance on this report shall constitute an acknowledgment, acceptance, and agreement by Client(s) as well as any spouse / significant other, and/or any assigns to all terms, conditions, exclusions and limitations of this report as well as an acknowledgment that the inspection includes only those items listed as inspected in the inspection report.