

LAWYERS TITLE CO.

GF# CF

Doc	Bk	Vol	Pa
01248904	OR	13045	165

**DECLARATION
OF COPPER CREEK CONDOS**

TABLE OF CONTENTS

Doc 8k Vol Pg
01248904 DR 13045 166

ARTICLE I.

Definition

1.1	Act	1
1.2	Association	1
1.3	Board	1
1.4	By-Laws	1
1.5	Common Elements	1
1.6	Common Expenses	2
1.7	Condominium	2
1.8	Declarant	2
1.9	Declarant Control Period	2
1.10	First Mortgage and First Mortgagee	2
1.11	Limited Common Elements	2
1.12	Occupant	3
1.13	Person	3
1.14	Plans	3
1.15	Plat	3
1.16	Property	3
1.17	Rules and Regulations	3
1.18	Special Declarant Rights	3
1.19	Unit	4
1.20	Unit Boundaries	4
1.21	Unit Owner	4
1.22	Additional Real Estate	4

ARTICLE II

Submission of Property to the Act

2.1	Submission	4
2.2	Name	4
2.3	Division of Property into Separately Owned Units	4
2.4	Alterations of Units	5
2.5	Limited Common Elements	5
2.6	Unit Allocations	5
2.7	Encumbrances	5
2.8	Condominium Ordinances	5
2.9	Reservation of Special Declarant Rights	5

TABLE OF CONTENTS

Doc Bk Vol Pg
01248904 DR 13045 167

ARTICLE III

Additional Real Estate

3.1	Declarant's Right to Add Additional Real Estate	5
3.2	Maximum Number of Additional Units; Units Restricted to Residential Use	5
3.3	Compatibility of Style, Etc	6
3.4	Applicability of Restrictions, Etc.	6
3.5	Other Improvements and Common Elements	6
3.6	Applicability of Assurances if Additional Real Estate Added	6
3.7	Allocation of Interest in Common Elements and Common Expenses	6

ARTICLE IV

Easements

4.1	Encroachments	6
4.2	Easements Through Walls	7
4.3	Easements to Repair, Maintain, Restore, and Reconstruct	7
4.4	Easements for Utilities	7
4.5	Declarant's Easement	7
4.6	Easements to Run with Land	9

ARTICLE V

Restrictions, Conditions, and Covenants

5.1	Compliance with Declarations, By-Laws, and Rules and Regulations	9
5.2	Administration of Condominiums	9
5.3	Use Restricted; Use by Declarant	9
5.4	Hazardous Use and Waste	10
5.5	Alterations of Common Elements	10
5.6	Prohibition of Renting for Transient or Hotel Purposes	11
5.7	Pets	11
5.8	Rules and Regulations	11
5.9	Restrictions, Conditions, and Covenants to Run with Land	11
5.10	Storage and Parking of Vehicles	11
5.11	Exterior and Visible Interior Improvements	12
5.12	Prohibitions on Use of Common Area and Facilities	12
5.13	Nuisances	12
5.14	Lawful Use	13
5.15	Access to Units	13

TABLE OF CONTENTS

Doc Bk Vol Pg
01248904 OR 13045 148

ARTICLE VI

Assessments

6.1	Assessment Liens	13
6.2	Personal Liability of Transferees; Statement; Liability of First Mortgage	13
6.3	Prohibition of Exemption from Liability for Contribution toward Common Expenses	14
6.4	Date of Commencement of Annual Assessments	14
6.5	Capitalization of Association	14

ARTICLE VII

Management, Maintenance, Repairs, Replacements, Alterations, and Improvements

7.1	Common Elements	15
7.2	Common Expenses Associated with Limited Common Elements or Benefitting Less Than All Units	15
7.3	Units	15
7.4	Waiver of Claims	16
7.5	Right of Entry	16

ARTICLE VIII

Insurance

8.1	Casualty Insurance	17
8.2	Public Liability Insurance	17
8.3	Fidelity Coverage	17
8.4	Insurance Unavailable	18
8.5	Other Insurance	18
8.6	Insurance Trustee	18
8.7	Individual Policy for Unit Owners	18

ARTICLE IX

Casualty Damage	18
-----------------	----

ARTICLE X

Condemnation	19
--------------	----

TABLE OF CONTENTS

Doc Bk Vol Ps
01242904 OR 13045 169

ARTICLE XI

Termination	19
-------------	----

ARTICLE XII

Amendment	19
-----------	----

ARTICLE XIII

Rights of First Mortgagees; FNMA and FHLMC Provisions

13.1	Amendments During Declarant Control Period	19
13.2	Availability of Condominium Documents, Books, Records, and Financial Statements	19
13.3	Successors Personal Obligation for Delinquent Assessments	20
13.4	Rights of Action	20
13.5	Management and Other Agreements	20
13.6	Right of First Refusal	20
13.7	Consent of First Mortgagees	20
13.8	Consent of First Mortgagees or Unit Owners	21
13.9	Notice	22
13.10	Assessments	23
13.11	Rights of First Mortgagee; Insurance Proceeds, or Condemnation Awards	23
13.12	Additional Real Estate: Consent of Administrator Common Element Interests; Reallocation	23

ARTICLE XIV

14.1	Conflict with the Act; Severability	23
14.2	Interpretation of Declaration	24
14.3	Captions	24
14.4	Exhibits	24
14.5	Invalidity	24
14.6	Waiver	24
14.7	Law Controlling	24

**DECLARATION OF COPPER CREEK CONDOS,
A CONDOMINIUM**

THIS DECLARATION is made this 16th day of November, 2015, by River Ridge Townhomes, Ltd., a Texas limited partnership ("Declarant"), acted for herein by its General Partner, SKYCO Management, L.L.C., a Texas limited liability company, pursuant to the Texas Uniform Condominium Act, Chapter 82, Property Code of the State of Texas ("Act").

WITNESSETH

WHEREAS, Declarant is the owner in fee simple of certain real estate situated in the City of College Station, County of Brazos and State of Texas more particularly described on Exhibit "A" attached hereto and made a part hereof, together with all buildings and improvements now or hereafter constructed or located thereon, and all rights, privileges, easements and appurtenances belonging to or in any way pertaining to said real estate; and

WHEREAS, Declarant desires to submit all of said property to the Act.

NOW, THEREFORE, Declarant, as the owner of said property, hereby declares as follows:

ARTICLE I
Definitions

Definitions. As used herein, the following words and terms shall have the following meanings:

- 1.1 Act. The Texas Uniform Condominium Act, Chapter 82, Property Code, State of Texas.
- 1.2 Association. COPPER CREEK CONDOS HOA, Inc., a nonprofit corporation organized under the Texas Non-Profit Corporation Act. The Certificate of Formation and Certificate of Filing of the Association are attached hereto as Exhibit "D".
- 1.3 Board. The Executive Board of the Association.
- 1.4 By-Laws. The By-Laws of the Association which are incorporated herein and made a part hereof by this reference, and attached as Exhibit "E".
- 1.5 Common Elements. All portions of the Condominium except the Units. Limited Common Elements are Common Elements. All water lines not located in street rights-of-way which serve the Property and all sewer lines not located in either street rights-of-way or City of College Station sanitary sewer easements which serve the Property are Common Elements. All storm water or drainage lines or facilities not within the City of College Station drainage easements are Common

Elements. Any amenities constructed on the Property, including, but not limited to, basketball court, if any, volleyball courts, if any, pool and adjacent patio and decks, picnic tables, barbecue grills, covered parking structures and play areas, are Common Elements.

- 1.6 Common Expenses. Expenditures made or liabilities incurred by or on behalf of the Association, together with any allocations to reserves and any ad valorem taxes or public assessments levied on Common Elements. (NOTE: There will be an individual water meter installed for each Unit, and each Unit Owner shall be responsible for making direct payment of the water and sewer bills for their Unit to the appropriate public utility.)
- 1.7 Condominium. The condominium created by this Declaration.
- 1.8 Declarant. River Ridge Townhomes, Ltd., a Texas limited partnership.
- 1.9 Declarant Control Period. The period commencing on the date hereof and continuing until the earlier of (i) the date two (2) years after Declarant has ceased to offer Units for sale in the ordinary course of business, or (ii) the date upon which Declarant surrenders control of the Condominium, or (iii) the date one hundred twenty (120) days after Declarant has conveyed seventy-five percent (75%) of the maximum number of Units which Declarant may create on the Phase 1 Property and on the Additional Real Estate, to Unit Owners other than a Declarant, or (iv) the date two (2) years after any development right to add New Units was last exercised by Declarant.
- 1.10 First Mortgage and First Mortgagee. A First Mortgage is a mortgage or deed of trust which has been recorded so as to give constructive notice thereof, and which is a first lien on the Unit or Units described therein. A First Mortgagee is the holder, from time to time, of a First Mortgage as shown by the records of the Office of the County Clerk for Brazos County, Texas in which the First Mortgage is recorded, including the Federal National Mortgage Association and including a purchaser at foreclosure sale upon foreclosure of a First Mortgage until expiration of the mortgagor's period of redemption. If there be more than one holder of a First Mortgage, they shall be considered as, and act as, one First Mortgage for all purposes under this Declaration and the By-Laws.
- 1.11 Limited Common Elements. Those portions of the Common Elements allocated by this Declaration, the Plans or by operation of Section 82.052 of the Act for the exclusive use of one but fewer than all of the Units including, but not limited to, any deck, balcony, porch or patio appurtenant to a Unit and any attic storage areas appurtenant to a Unit. That portion of the Property upon which heating and air conditioning equipment serving a Unit is located shall constitute a Limited Common Element allocated specifically to the Unit served by such equipment.

- 1.12 Occupant. Any person or persons in possession of a Unit, including Unit Owners, the family members, lessees, guests and invitees of such person or persons and family members, guests and invitees of such lessees.
- 1.13 Person. A natural person, corporation, partnership, trust or other legal or commercial entity, or any combination thereof.
- 1.14 Plans. The plans of the Condominium, including, but not limited to, the Plat recorded in the Office of the County Clerk for Brazos County, Texas and by the Act made a part of this Declaration.
- 1.15 Plat. The survey plat depicting the Condominium and the location of the buildings on the Property, recorded in the Office of the County Clerk for Brazos County, Texas, and by the Act made a part of this Declaration.
- 1.16 Property. The real estate described on Exhibit "A", together with all buildings, amenities and other improvements now or hereafter constructed or located thereon, and all rights, privileges, easements and appurtenances belonging to or in any way pertaining to said real estate.
- 1.17 Rules and Regulations. The rules and regulations of the Condominium promulgated by the Executive Board from time to time.
- 1.18 Special Declarant Rights. The rights as defined in Section 82 of the Act for the benefit of a Declarant, including but not limited to the following: to complete the improvements indicated on the Plans (Section 82.003(a)(22)(A), Section 82.059); to maintain sales offices, management offices, models and signs advertising the Condominium (Section 82.003(a)(22)(D), Section 82.065); to exercise any development right (Section 82.003(a)(22)(B), Section 82.06); to use and allow others to use easements through the Common Elements (Section 82.003(a)(22)(E), Section 82.066); to elect, appoint or remove members of the Board during the Declarant Control period (Section 82.003 (a)(22)(F), Section 82.103 C); and to withdraw any portion of the Property from the Condominium. Declarant shall have the right to subdivide or convert Units owned by Declarant.

Further, for a period of ten (10) years from the date of this Declaration, Declarant reserves the right, at any time, and in any order: to add all or any portion of the Additional Real Estate, together with any buildings, amenities or other improvements now existing or constructed thereon, to the Condominium; to construct, or not to construct, at Declarant's option, any or all of the buildings, amenities or other improvements shown on a Plat; and to construct any other improvements on the Additional Real Estate. The addition of any or all of the Additional Real Estate to the Condominium, and the construction of any buildings,

amenities (swimming pool, clubhouse, basketball court, volleyball court, etc.) or other improvements on the Additional Real Estate, shall, however, be at the sole discretion of Declarant, and any or all of the buildings, amenities or other improvements shown on the above-referenced Plat "**NEED NOT BE BUILT**".

- 1.19 Unit. A portion of the Condominium, whether or not contained solely or partially within a building, together with its percentage of undivided interest in the Common Elements as set forth on Exhibit "B". Each Unit is designated and delineated on the Plans.
- 1.20 Unit Boundaries. The boundaries of each Unit, both as to vertical and horizontal planes, as shown on the Plans, are the undecorated surfaces of the perimeter walls, exterior doors and exterior windows facing the interior of the Unit, the undecorated surfaces of the ceiling facing the interior of the Unit, and the topmost surfaces of the subflooring, and include the decoration on all such interior and topmost surfaces, including, without limitation, all paneling, tiles, wallpaper, paint, finished flooring and any other materials constituting any part of the decorated surfaces thereof, and also includes all spaces, interior partitions and other fixtures and improvements within such boundaries. Also included as a part of the Unit shall be those portions of the heating and air conditioning system for the Unit which are located within the perimeter walls of the Unit and those portions of the heating and air conditioning system located in the Common Elements, wherever located.
- 1.21 Unit Owner. The person or persons, including the Declarant, owning a Unit in fee simple.
- 1.22 Additional Real Estate. The real estate, if any, shown on the Plat as a portion of the Property other than Phase I, together with all buildings and improvements now or hereafter constructed or located thereon, and all rights, privileges, easements and appurtenances belonging to or in any way pertaining to said real estate.

ARTICLE II

Submission of Property to the Act

- 2.1 Submission. Declarant hereby submits the Property to the Act.
- 2.2 Name. The Property shall hereafter be known as COPPER CREEK CONDOS.
- 2.3 Division of Property into Separately Owned Units. Declarant, pursuant to the Act, and to establish a plan of condominium ownership for the Condominium, does hereby create Phase I, with such phase hereby divided into nineteen (19) Units, and does hereby designate all such Units for separate ownership, subject however, to the provisions of Section 2.4 hereof.

- 2.4 Alterations of Units. Subject to the provisions of the By-Laws, a Unit may be altered pursuant to the provisions of Section 82.061, 82.062, and 82.063 of the Act.
- 2.5 Limited Common Elements. The Limited Common elements serving or designed to serve each Unit are hereby allocated solely and exclusively to each such Unit.
- 2.6 Unit Allocations. The allocations to each Unit of a percentage of undivided interest in the Common Elements and of a percentage of the Common Expenses are as stated on Exhibit "B". The allocation of undivided interest in the Common Elements and of the Common Expenses has been determined by a ratio formulated upon the relation that each Unit bears to the total number of Units. The votes are equally allocated to all Units with each Unit Owner having one (1) vote for each Unit owned.
- 2.7 Encumbrances. The liens, defects and encumbrances affecting the Property to which the rights of Unit Owners and Occupants are hereby made subject are set out on Exhibit "C".
- 2.8 Condominium Ordinances. The Condominium is not subject to any code, real estate use law, ordinance, charter provisions, or regulation (i) prohibiting the condominium form of ownership, or (ii) imposing conditions or requirements upon a condominium which are not imposed upon physically similar developments under a different form of ownership.
- 2.9 Reservation of Special Declarant Rights. Declarant hereby reserves all Special Declarant Rights, as defined in Article 1.18.

ARTICLE III
Additional Real Estate

- 3.1 Declarant's Right to Add Additional Real Estate. Declarant expressly reserves the right to add the Additional Real Estate to the Condominium. All or part of the Additional Real Estate identified and described on The Plat may be added to the Condominium at different times, but no assurances are made in regard to the order in which such portions may be added. Declarant shall have no duty or obligation of any kind to add any or all of the Additional Real Estate. The method of adding the Additional Real Estate shall be pursuant to Section 82.060 of the Act.
- 3.2 Maximum Number of Additional Units: Units Restricted to Residential Use. The maximum number of additional Units that may be created within the Additional Real Estate is thirty-five (35) Units, for a total of fifty-four (54) Units on all of the Property. All of such Units will be restricted to residential use.

- 3.3 Compatibility of Style, etc. It is Declarant's present intent that any buildings, amenities and Units that may be erected upon the Additional Real Estate, or a portion thereof, will be compatible with the other buildings and improvements in the Condominium in terms of architectural style, quality of construction, and size. However, Declarant expressly reserves the right to change the architectural style, size and location of any buildings, amenities and Units that may be erected upon the Additional Real Estate.
- 3.4 Applicability of Restrictions, Etc. All restrictions in this Declaration and the By-Laws affecting use, occupancy and alienation of Units will apply to any and all additional Units that may be created within the Additional Real Estate.
- 3.5 Other Improvements and Common Elements. In addition to the buildings and Units that may be erected upon the Additional Real Estate or a portion thereof, the other improvements and Common Elements that may be made or created upon or within the Additional Real Estate or each portion thereof which may be added to the Condominium will be generally similar in quality and quantity to the improvements and Common Elements located in the Condominium.
- 3.6 Applicability of Assurances if Additional Real Estate Not Added. The assurances made in this Article III will not apply with respect to any Additional Real Estate that is not added to the Condominium. In the event that Declarant shall not expand the Condominium by the use or any portion of Additional Real Estate, Declarant shall have the right to develop all or any portion of the Additional Real Estate without restriction.
- 3.7 Allocation of Interest in Common Elements and Common Expenses. If Declarant adds the Additional Real Estate, or portions thereof, to the Condominium, the percentage interest of each Unit Owner in the Common Elements and the Common Expenses will be determined by a ratio formulated upon the relation that each Unit bears to the total number of Units in the Condominium.

ARTICLE IV

Easements

- 4.1 Encroachments. In the event that, by reason of the construction, reconstruction, rehabilitation, alteration or improvement of the buildings or improvements comprising a part of the Property, any part of the Common Elements now or hereafter encroaches upon any part of any Unit, or any part of Common Elements, or upon any part of another Unit, an easement for the continued existence and maintenance of each such encroachment is hereby declared and granted and shall continue for so long as each such encroachment exists; provided that in no event shall an easement for such encroachment be created if such encroachment is

detrimental to or interferes with the reasonable use and enjoyment of the Common Elements or Units so encroached upon.

- 4.2 Easements Through Walls. Easements are hereby declared and granted to the Association and to such persons as are authorized by the Association, to install, lay, maintain, repair and replace any chutes, flues, ducts, vents, pipes, wires, conduits and other utility installations, and structural components running through the walls of the Units, whether or not such walls lie in whole or in part within the boundaries of any Unit.
- 4.3 Easements to Repair, Maintain, Restore and Reconstruct. Wherever in, and whenever by, this Declaration, the By-Laws or the Act, a Unit Owner, the Association, the Board or any other person, is authorized to enter upon a Unit or the Common Elements to inspect, repair, maintain, restore or reconstruct all or any part of a Unit or the Common Elements, such easements as are necessary for such entry and such repair, maintenance, restoration or reconstruction are hereby declared and granted.
- 4.4 Easements for Utilities. The Units and Common Elements shall be, and are hereby, made subject to easements in favor of the Declarant (until Declarant shall have satisfied all of its obligations under the Declaration and By-Laws and all commitments in favor of any Unit Owner and the Association), the Association, appropriate utility and service companies and governmental agencies or authorities for such utility and service lines and equipment as may be necessary or desirable to serve any portion of the Property. The easements provided for by this Section 4.4 shall include, without limitation, rights of Declarant, the Association, any providing utility, any service company, and any governmental agency or authority and any of them to install, lay, maintain, repair, relocate and replace gas lines, pipes and conduits, water mains and pipes, sewer and drain lines, telephone wires and equipment, television and equipment facilities (cable or otherwise), electrical wires, conduits and equipment and ducts and vents and any other appropriate equipment and facilities over, under, through, along and on the Units and Common Elements. Notwithstanding the foregoing provisions of this Section 4.4, unless approved in writing by the Unit Owner or Unit Owners affected thereby, any such easement through a Unit shall be located either in substantially the same location as such facilities or similar facilities which existed at the time of first conveyance of the Unit by the Declarant to a grantee other than the Declarant, or so as not to materially interfere with the use or occupancy of the Unit by its Owners.
- 4.5 Declarant's Easement.
- a) Declarant hereby reserves such easements through the Common Elements as may be reasonably necessary for the purposes of discharging its obligations, exercising Special Declarant Rights, and completing the development and

construction of the Condominium, which easements shall exist as long as reasonably necessary for such purpose.

- b) Declarant, its successors, transfers and assigns, owning the Additional Real Estate, or any portion thereof, and the mortgagees of Declarant, its successors, transfers and assigns, owning the Additional Real Estate, or any portion thereof, shall have and does hereby reserve a perpetual nonexclusive right and easement of use of those portions of the Common Elements of the Condominium used as driveways, including the Driveway Entrance from Southwest Parkway and of use of any and all waterlines; sewer lines; lift station; storm water detention ponds; drainage easements; storm drains; electric, telephone, or cable television wires or conduits; gas lines or similar utility facilities that are part of the Common Elements, to the extent reasonably necessary for Declarant, or such other owner of the Additional Real Estate, or a portion thereof, to have ingress and egress to and from the Additional Real Estate over the Common Elements, and to provide drainage facilities and utility service including sewer lines, the use of the lift station and the use of the storm water detention ponds' drainage easements, storm drains and other drainage facilities, to the Additional Real Estate. Provided, however, the owner of the Additional Real Estate exercising such rights and easements shall contribute a reasonable pro-rata share of the cost of the operation and maintenance of the lift station another utility facilities and other portions of the Common Elements so utilized. These easements and rights may not be changed without the prior written consent of all parties entitled to the exercise of such easements and rights. Any easement rights of the mortgagees of Declarant, its successors, transfers and assigns, provided for herein, shall terminate upon satisfaction and cancellation of that mortgagees' deed of trust.
- c) Declarant, its successors, transfers and assigns, owning the Additional Real Estate, or any portion thereof, and the mortgagees of Declarant, its successors, transfers and assigns, owning the Additional Real Estate, or any portion thereof, shall have and does hereby reserve a perpetual nonexclusive right and easement of use of those portions of the Common Elements that may be constructed as recreational amenities of the Condominium (basketball court, if any, volleyball court, if any, pool and adjacent patio and decks, and clubhouse), provided, however, the owner of the Additional Real Estate exercising such rights and easements shall contribute a reasonable pro rata share of the cost of the operation and maintenance of such amenities so utilized. These easements and rights may not be changed without the prior written consent of all parties entitled to the exercise of such easements and rights. Any easement rights of the mortgagees of Declarant, its successors, transfers and assigns, as provided

for herein, shall terminate upon satisfaction and cancellation of the mortgagee's deed of trust.

- 4.6 Easements to Run With Land. All easements and rights described in this Article IV are appurtenant easements running with the land, and except as otherwise expressly provided in this Article IV shall be perpetually in full force and effect, and shall inure to the benefit of and be binding upon Declarant, its successors and assigns owning the Additional Real Estate, or any portion thereof of Declarant's mortgagees, the Association, Unit Owners, Occupants, First Mortgagees and any other person having any interest in the Condominium or any part thereof. The Condominium and every part thereof shall be conveyed and encumbered subject to and together with all easements and rights described in this Article IV, whether or not specifically mentioned in any such conveyance or encumbrance.

ARTICLE V
Restrictions, Conditions and Covenants

- 5.1 Compliance with Declaration, By-Laws and Rules and Regulations. Each Unit Owner and Occupant shall comply with all applicable provisions of the Act, this Declaration, the By-Laws, the Certificate of Formation of the Association, and the Rules and Regulations promulgated by the Board or the Association, as amended. Failure to comply shall be grounds for an action by the Association, an aggrieved Unit Owner, or any person adversely affected, for recovery of damages, injunction, or other relief.
- 5.2 Administration of Condominium. The Condominium shall be administered in accordance with the provisions of the Act, this Declaration and the By-Laws.
- 5.3 Use Restricted: Use by Declarant.
- (a) Except as may be otherwise expressly provided in this Declaration, each unit shall be used for residential purposes only and shall be occupied by no more than four (4) unrelated persons or six (6) related persons on a permanent basis. No trade or business of any kind may be conducted. Lease or rental of a unit for residential purposes shall not be considered to be a violation of this Covenant, so long as the lease is in compliance with the provisions of this Declaration, the By-Laws and reasonable Rules and Regulations adopted by the Board.
 - (b) Except as reserved by Declarant, no advertising signs (except one "For Rent" or "For Sale" sign per Unit of not more than 1' x 2' if placed in a window, or 2' x 3.5' if placed in the Common Area immediately in front of the Unit), billboards, unsightly objects, or nuisances shall be erected, placed or permitted to remain on the property subject to this Declaration.

- c) The foregoing provisions of this Section or any other provision of this Declaration or the By-Laws notwithstanding, Declarant shall have an easement to maintain sales offices (sales offices may be located in one or more Units and/or the clubhouse, if constructed) and models for sales of Units throughout the Condominium. Declarant shall have the right to relocate, from time to time, and to discontinue and reestablish, from time to time, within the Condominium, until all of the Units have been conveyed to a Unit Owner other than a Declarant, any one or more of such offices or models. Declarant also shall have the right to change the use or combination of uses of such offices or models, provided that such offices or models shall be used only for sales offices or models. The total number of such offices or models maintained at any time by a Declarant shall not exceed four (4), and the size of any such relocated or re-established office or model shall not exceed the size of the largest Unit in the Condominium.
- d) Declarant shall also have an easement to maintain signs on the Common Elements advertising the Condominium until all of the Units have been conveyed to Unit Owners other than a Declarant. Declarant shall remove all such signs not later than one (1) year after all of the Units have been conveyed to Unit Owners other than Declarant and shall repair or pay for the repair of all damage done by removal of such signs.
- e) The foregoing provisions of this Section or any other provision of this Declaration or the By-Laws notwithstanding, the Association may maintain an office in the Condominium for management of the Condominium, which office may be located in one or more Units or the clubhouse (if constructed).

5.4 Hazardous Use and Waste. Nothing shall be done to or kept in any Unit or the Common Elements that will increase any rate of insurance maintained with respect to the Condominium without the prior written consent of the Board. No Unit Owner or Occupant shall permit anything to be done to or kept in his or her Unit or the Common Elements that will result in the cancellation of insurance maintained with respect to the Condominium, or that would be in violation of any law, or that will result in the commitment of waste (damage, abuse, or destruction) to or in his Unit or the Common Elements.

5.5 Alterations of Common Elements. No Unit Owner or Occupant, except Declarant during the Declarant Control Period, shall alter, construct anything upon, or remove anything from, the Common Elements, or paint, decorate, landscape or adorn any portion of the Common Elements, without the prior written consent of the Board.

- 5.6 Prohibition of Renting for Transient or Hotel Purposes. No Unit Owner shall rent his, her or its Unit for transient or hotel purposes, which, for the purposes of this Declaration shall be defined as either a rental for any period less than thirty (30) days or any rental if the lessee of the Unit is provided customary hotel services except as follows: a Unit Owner may allow short term rental for events related to activities at Texas A&M University during the main academic year including, but not limited to, football games, graduation, reunion weekends, Parent's Weekend, and Muster. Each permitted lease shall be in writing and shall be subject to this Declaration, the By-Laws, and the Rules and Regulations adopted hereunder and any failure of the lessee to comply with the terms of such documents shall be a default under the lease. Other than the foregoing restrictions, each Unit Owner shall have the full right to lease all or any portion of his Unit.
- 5.7 Pets. With the exception of domesticated fish and birds and dogs or cats weighing less than forty (40) pounds (which may be kept inside a Unit provided that they do not become a nuisance to any other Unit Owner), no pets, animals, livestock, or poultry of any kind shall be raised, bred, or kept on the property.
- 5.8 Rules and Regulations. In addition to the foregoing restrictions, conditions and covenants concerning the use of the Condominium, reasonable rules and regulations not in conflict therewith and supplementary thereto may be promulgated and amended from time to time by the Board or the Association, as more fully provided in the By-Laws.
- 5.9 Restrictions, Conditions and Covenants to Run With Land. Each Unit Owner and Occupant shall be subject to all restrictions, conditions and covenants of this Declaration, and all such restrictions, conditions and covenants shall be deemed to be covenants running with the land, and shall bind every person having any interest in the Property, and shall inure to the benefit of every Unit Owner.
- 5.10 Storage and Parking of Vehicles. No motor vehicle (other than private passenger vehicles including motorcycles and pick-up and small trucks which shall be currently licensed and inspected) including commercial vehicles, trucks (other than pick-up and small truck), tractors, mobile homes or trailers (either with or without wheels), campers, camper trailers, boats or other water crafts, boat trailers, or any other transportation devices of any kind, shall be parked or stored in or upon the Common Elements except in any area provided by the Association for such storage and subject to rules, regulations and fees charged by the Association, or parked or stored within any street right-of-way. One such area shall be the designated Island Parking Area in the center of the Condominium as is depicted in the final survey. Each Unit Owner shall be entitled to the use of one (1) parking space per bedroom. The Board shall be entitled and is hereby authorized to sell, for a fee, additional parking space rights to any Unit Owner or Occupant, on such terms and at such price as the Board may determine. No Unit Owner or Occupant shall repair or

restore any vehicle of any kind upon the property, except for emergency repairs, and then only to the extent necessary to enable movement thereof to a proper repair facility. All vehicles must have current motor vehicle registration in the state of primary residence of the Unit Owner or Occupant.

5.11 Exterior and Visible Interior Improvements.

- a) No awnings, shades, screens or other items shall be attached to, hung or used on the exterior of any window or door of a unit or on the exterior of any building without the prior written consent of the Board of Directors. All shades, blinds, drapery linings and other window treatments visible from the exterior of a unit on any window or door shall be white or off-white. Outside clotheslines or other outside facilities for drying or airing clothes are specifically prohibited and shall not be erected, placed or maintained on any portion of the Condominium, nor shall any clothing, rugs, or any other items be hung on any railing or fence enclosing any balcony, porch, patio or deck.
- b) No unit owner shall install any electrical or telephone wire, television antenna, satellite dishes, air conditioning unit, or other machine anywhere on the Condominium outside of a Unit without the approval of the Board of Directors.

5.12 Prohibitions on Use of Common Elements. Except with the specific written approval of the Board, the Common Elements, including Limited Common Elements, shall not be used for temporary or permanent storage or supplies, personal property, trash or refuse of any kind, other than in common trash receptacles placed at the discretion of the Board, nor shall such areas be used in any way for the drying or airing of clothing, rugs or other fabrics. Entrances, sidewalks, yards, driveways, parking areas and stairways shall not be obstructed in any way. No activities shall be carried on nor condition maintained by any Unit Owner, either in his Unit or upon the Common Elements, if such activities should despoil, or tend to despoil, the appearance of the Property. No "garage", "attic sales" or "yard sales" shall be permitted outside of a Unit. It is expressly acknowledged and agreed by all parties concerned that this Section is for the mutual benefit of all Unit Owners of the Property and is necessary for the protection of the Unit Owners and is enforceable by the Board or by any one or more Unit Owners through the Board of Directors.

5.13 Nuisances. No nuisances shall be allowed upon the Property and no person shall engage in any use, practice or activity upon the Property which is noxious, offensive or a source of annoyance to Unit Owners or their tenants or which reasonably interferes with the peaceful possession and proper use of the Condominium Property by any Unit Owner and/or tenants. No exterior speakers,

horns, whistles, bells or other sound devices except security devices used exclusively for security purposes, shall be located, used or placed on the Property. All parts of the Property shall be kept in a clean and sanitary condition, and no rubbish, refuse or garbage shall be allowed to accumulate and no fire hazard shall be allowed to exist. Any Unit Owner who shall dump or place (or permit his family, tenants, guests or agent to do so) any trash or debris upon any portion of the Property shall be liable to the Association for the actual cost of removal thereof or the sum of \$100.00, whichever is greater, and the same shall be added to and become a part of the assessment next coming due to which the Unit Owner or his Unit is subject. No Unit Owner shall permit any use of a Unit or of the Common Elements which will increase the rate of insurance upon the Property. The Association and its Agent shall have the right to remove any item or items left outside a Unit on the Common Elements or hanging from a balcony.

- 5.14 Lawful Use. No immoral, improper or unlawful use shall be made of the Condominium Property or any part thereof. All valid laws, zoning ordinances and regulations of governmental bodies having jurisdiction thereof shall be observed.
- 5.15 Access to Units. The Association and its agent shall have access to each Unit from time to time during reasonable working hours, upon oral or written notice to its Unit Owner or occupant of the Unit, as may be necessary for the maintenance, repair or replacement of any of the Common Elements. The Association and its agents shall also have access to each Unit at all times without notice, as may be necessary to make emergency repairs to prevent damage to Common Elements.

ARTICLE VI Assessments

- 6.1 Assessment Liens. The Board has the power to levy assessments against the Units for Common Expenses. Such assessments, together with interest at the rate of ten percent (10%) per annum, costs and reasonable attorney's fees shall be a lien on the Units against which they are assessed, and if any payment thereof becomes delinquent, the lien may be foreclosed and the Unit sold, or a money judgment obtained against the persons liable therefor, all as set forth in the By-Laws.
- 6.2 Personal Liability of Transferees: Statement: Liability of First Mortgage.
- a) The personal obligation for assessments which are delinquent at the time of transfer of a Unit shall not pass to the transferee of said Unit unless said delinquent assessments are expressly assumed by said transferee.
 - b) Any transferee referred to in (a) above shall be entitled to a statement from the Board, pursuant to Section 6.2 of the By-Laws, and such transferee's

Unit shall not be subject to a lien for any unpaid assessments against such Unit in the amount therein set forth.

- c) Where a First Mortgagee, or other person claiming through such First Mortgagee, pursuant to the remedies provided in a mortgage or deed of trust, or by foreclosure or by deed, or assignment, in lieu of foreclosure, obtains title to a Unit, the liability of such First Mortgagee or such other person for assessments shall be only for the assessments, or installments thereof, that would become delinquent, if not paid, after acquisition of title. For purposes hereof, title to a Unit shall be deemed acquired by foreclosure upon expiration of the applicable period of redemption. The lien for assessments shall be subordinate to the lien of the First Mortgagee at all times, and a sale or transfer pursuant to a foreclosure of the deed of trust lien of the First Mortgagee will extinguish all assessments as to the First Mortgagee, or its successors and assigns, which have become due prior to the foreclosure date.
- d) Without releasing the transfer or from any liability therefore, any unpaid portion of assessments which is not a lien under (b) above, or, resulting, as provided in (c) above, from the exercise of remedies in a mortgage or deed of trust, or by foreclosure thereof or by deed, or assignment, in lieu of such foreclosure, shall be a Common Expense collectible from all Unit Owners, including the transferee under (b) above and the First Mortgagee of such other person under (c) above who acquires ownership by foreclosure or by deed, or assignment, in lieu of foreclosure.

- 6.3 Prohibition of Exemption from Liability for Contribution Toward Common Expenses. No Unit Owner may exempt himself from liability for his share of the Common Expenses assessed by the Association by waiver or the use or enjoyment of any of the Common Elements or by abandonment of his Unit or otherwise.
- 6.4 Date of Commencement of Annual Assessments. The annual assessments provided for herein shall commence as to all Units on the first day of the month following the conveyance of the first Unit by the Declarant. The first annual assessment shall be adjusted according to the number of months then remaining in that fiscal year. The initial monthly assessment for the first calendar year shall not exceed One Hundred and No/100 Dollars (\$100.00) per month with the Board reserving the right to charge a lesser amount for the first year.
- 6.5 Capitalization of Association. Upon acquisition of record title to a Unit, each Owner shall contribute to the capital of the Association an amount equal to one-sixth (1/6) of the amount of the annual assessment for that Unit as determined by the Board. This amount shall be paid by the buyer at the closing of the purchase of the Unit and shall be disbursed to the Association. This initial capitalization shall

not be an advance payment of assessments. It is merely an initial capital contribution.

ARTICLE VII
Management, Maintenance, Repairs
Replacements, Alterations and Improvements

7.1 Common Elements.

- a) By the Association: The management, replacement, maintenance, repair, alteration, and improvement of the Common Elements shall be the responsibility of the Association, and subject to the provisions of Section 7.2 hereof, the cost thereof shall be a Common Expense to the extent not paid by Unit Owners pursuant to Section 7.1 (b) hereof. All damage caused to a Unit by any work on or to the Common Elements done by or for the Association shall be repaired by the Association, and the cost thereof shall be a Common Expense.
- b) By Unit Owners: Each Unit Owner shall pay all costs to repair and replace all portions of the Common Elements that may become damaged or destroyed by reason of his intentional or negligent acts or the intentional or negligent acts of any Occupant of his Unit. Such payment shall be made upon demand made by the Association.

7.2 Common Expenses Associated with Limited Common Elements or Benefiting Less Than All Units.

- a) Any Common Expenses associated with the maintenance, repair, or replacement of a Limited Common Element shall be assessed against the Unit, or in equal shares to the Units, to which such Limited Common Element was allocated at the time the expense was incurred.
- b) In addition, the Association may assess any Common Expense benefiting less than all of the Units against the Units benefited in proportion to their Common Expense liability.

7.3 Units. Each Unit Owner shall maintain his Unit, and any limited Common Elements appurtenant thereto, at all times in a good and clean condition, and repair and replace, at his expense, all portions of his Unit; shall perform his responsibilities in such a manner as not to unreasonably disturb other Occupants; shall promptly report to the Board, or its agents, any defect or need for repairs the responsibility for which is that of the Association; and, to the extent that such expense is not covered by the proceeds of insurance carried by the Association, shall pay all costs to repair and replace any portion of another Unit that has become

damaged or destroyed by reason of his own acts or omissions, or the acts or omissions of any Occupant of his Unit. Such payment shall be made upon demand by the Unit Owner of such other Unit. Nothing herein contained shall modify any waiver by insurance companies of rights of subrogation.

7.4 Waiver of Claims. Except only as provided in Section 7.5(a) and (b), the Association agrees that it shall make no claim against a Unit Owner or Occupant, and each Unit Owner and Occupant agrees that he shall make no claim against the Association, the members of the Board, officers of the Association, or employees or agents of any thereof, or against any manager retained by the Board, or his or its officers, directors, employees or agents, or other Unit Owners or Occupants, for any loss or damage to any of the Property, or to a Unit of personal property therein, even if caused by the omission or neglect of any one or more of such persons, and all such claims are hereby waived and released; provided, that this waiver shall not apply to any such loss or damage due to intentional acts.

7.5 Right of Entry.

- (a) By the Association. The Association, and any person authorized by the Association, may enter any Unit or any of the Limited Common Elements in case of any emergency or dangerous conditions or situation originating in or threatening that Unit or any of the Limited Common Elements. The Association, and any person authorized by the Association, after reasonable notice to a Unit Owner or Occupant, may enter that Unit or any of the Limited Common Elements for the purposes of performing any of the Association's powers under the Act, this Declaration or the By-Laws with respect to that or any other Unit, any Limited Common Elements, or the Common Elements. Notwithstanding Section 7.4, the Association shall be responsible for the repair of any damage caused by the Association or its authorized person to the entered Unit, and the cost thereof shall be a Common Expense. All such entries shall be made and done so as to cause as little inconvenience as possible to the Unit Owner and Occupant of the entered Unit or any portion of the Limited Common Elements allocated to the Unit Owner.
- (b) By Unit Owners. Each Unit Owner and Occupant shall allow other Unit Owners and Occupants, and their representatives, to enter his Unit, or Limited Common Elements allocated to his Unit, when reasonably necessary for the purpose of altering, maintaining, repairing or replacing the Unit, or performing the duties and obligations under the Act, this Declaration or the By-Laws, of the Unit Owner or Occupant making such entry, provided that requests for entry are made in advance and that such entry is at a time convenient to the Unit Owner or Occupant whose Unit or Limited Common Element is to be entered. In case of an emergency or

dangerous condition or situation, such right of entry shall be immediate. Notwithstanding Section 7.4, the person making such entry shall be responsible for repair of any damage caused by such person to the entered Unit or Limited Common Element.

ARTICLE VIII

Insurance

- 8.1 Casualty Insurance. The Association shall maintain, to the extent available, casualty insurance upon the Property in the name of, and the proceeds thereof shall be payable to, the Association as trustee for all Unit Owners and First Mortgagees as their interest may appear, and be disbursed pursuant to the Act. Such insurance shall be in an amount equal to not less than one hundred percent (100%) of the full insurable value of the Property on a replacement cost basis exclusive of land, excavations, foundations and other items normally excluded from property policies, and shall insure against such risks and contain such provisions as the Board from time to time shall determine, but at a minimum shall conform in all respects to the requirements of the Act, and shall provide that, notwithstanding any provision thereof that gives the insurer an election to restore damage in lieu of making a cash settlement, such option shall not be exercisable if such restoration is prohibited pursuant to Section 82.111 of the Act.
- 8.2 Public Liability Insurance. The Association shall maintain public liability insurance for the benefit of the Unit Owners, Occupants, the Association, the Board, the managing agent, if any, the Declarant, and their respective officers, directors, agents and employees, in such amounts and with such coverage as shall be determined by the Board; provided that the public liability insurance shall be for at least One Million Dollars (\$1,000,000.00) per occurrence for death, bodily injury and property damage. Said insurance shall comply in all respects with the requirement of the Act and shall contain a severability-of-interest endorsement precluding the insurer from denying liability because of negligent acts of any insured; insure all of such benefited parties against such liability arising out of or in connection with the use, ownership or maintenance of the Common Elements, and the streets, sidewalks and public spaces adjoining the Condominium; and insure the Association, the Board, the managing agent, if any, and their respective officers, directors, agents and employees against such liability arising out of or in connection with the use or maintenance of the Units.
- 8.3 Fidelity Coverage. If available at reasonable cost, fidelity coverage shall be maintained by the Association in commercial blanket form covering each director and officer of the Association, any employee or agent of the Association and any other person handling or responsible for handling funds of the Association in the face amount of at least the greater of (i) one and one-half (1-1/2) times the estimated annual operating expenses and reserves of the Association, or (ii) the sum

of three months' aggregate assessments on all Units plus the Association's reserve funds. Such bonds shall contain an appropriate endorsement to cover persons who serve without compensation. The premium on such bonds shall be a Common Expense.

- 8.4 Insurance Unavailable. If the insurance described in Sections 8.1, 8.2, or 8.3 is not reasonably available, the Association shall promptly cause notice of such fact to be hand-delivered or sent prepaid by United States mail to all Unit Owners.
- 8.5 Other Insurance. The Association may procure such other insurance, including worker's compensation insurance, as it may from time to time deem appropriate to protect the Association or the Unit Owners. If at least one Unit is subject to mortgage financing, the Association shall obtain and keep in force such insurance as such mortgagee shall reasonably require from time to time.
- 8.6 Insurance Trustee. The Board may engage, and pay as a Common Expense, any appropriate person to act as an insurance trustee to receive and disburse insurance proceeds upon such terms as the Board shall determine, consistent with the provisions of the Act and this Declaration.
- 8.7 Individual Policy for Unit Owners. Each Unit Owner may obtain insurance, at his own expense, affording personal property, additional living expense, condominium assessment, personal liability, and any other coverage obtainable, to the extent and in the amounts such Unit Owner deems necessary to protect his own interest; provided that any such insurance shall contain waivers pursuant to Section 7.4 and shall provide that it is without contribution as against the insurance purchased by the Association. If a casualty loss is sustained and there is a reduction in the amount of the proceeds that would otherwise be payable on the insurance purchased by the Association due to the proration of the insurance purchased by a Unit Owner under this Section, such Unit Owner shall be liable to the Association to the extent of such reduction and shall pay the assigns the proceeds of his insurance, to the extent of such reduction, to the Association.

ARTICLE IX Casualty Damage

If all or any part of the Property shall be damaged or destroyed, the same shall be repaired or replaced unless: (i) the Condominium is terminated, (ii) repair or replacement would be illegal under any State or local health or safety statute or ordinance, or (iii) the Unit Owners elect not to rebuild or replace by a ninety percent (90%) vote, including one hundred percent (100%) approval of owners of Units not to be rebuilt or owners assigned to Limited Common Elements not to be rebuilt. All proceeds of insurance shall be used and applied in accordance with the provisions of Section 82.111 of the Act.

ARTICLE X
Condemnation

In the event of a taking by eminent domain, or by a conveyance in lieu thereof, of all or any part of the Property, the awards paid on account thereof shall be applied in accordance with Section 82.007 of the Act and Section 9.2 of the By-Laws.

ARTICLE XI
Termination

The Condominium may be terminated only in strict compliance with Section 82.068 of the Act and Section 9.4 of the By-Laws.

ARTICLE XII
Amendment

This Declaration may be amended only in strict compliance with 82.007, 82.051 (C), 82.056 (D), 82.058(B), 82.058 (C), 82.059(F), 82.062, 82.062, 82.063, 82.063 (B), 82.067, and 82.068(B) of the Act, except that no amendment altering or impairing Special Declarant Rights may be made without the written consent of Declarant.

In the event the Declarant has arranged for and provided purchasers of Units with VA and/or FHA insured mortgage loans, then as long as Declarant owns twenty-five percent (25%) of the Units in all Phases of the Condominium, the following actions will require the prior written approval of the Federal Housing Administration and/or the Veterans Administration: Amendment of the Declaration or merger or consolidation with another condominium.

ARTICLE XIII
Rights of First Mortgagees:
FNMA and FHLMC Provisions

The following provisions shall take precedence over all other provisions of this Declaration and By-Laws:

- 13.1 Amendments During Declarant Control Period. Any amendments to this Declaration or to the By-Laws during the Declarant Control Period shall be subject to the prior approval of all First Mortgagees, provided, however, that, if any First Mortgagee fails to respond to a written request for approval within thirty (30) days of said request, approval shall be deemed to have been given by such First Mortgagee.
- 13.2 Availability of Condominium Documents: Books, Records and Financial Statements. The Association shall, upon request and during normal business hours,

make available for inspection by Unit Owners and the First Mortgagees and insurers and guarantors of a First Mortgage on any Unit, current copies of the Declaration, By-Laws, other rules and regulations governing the Condominium and the books, records and financial statements of the Association. The Association shall provide a financial statement for the preceding fiscal year if requested in writing by a First Mortgagee or insurer or guarantor of a First Mortgage. The Association shall, upon request and during normal business hours, make available for inspection by prospective purchasers of Units, current copies of the Declaration, By-Laws, Rules and Regulations governing the Condominium, and the most recent annual financial statement.

- 13.3 Successor's Personal Obligation for Delinquent Assessments. The personal obligations of a Unit Owner shall not pass to or be charged against a First Mortgagee, but shall be an obligation of any subsequent Unit Owner who purchases a Unit from a Unit Owner other than a First Mortgagee.
- 13.4 Rights of Action. The Association and any aggrieved Unit Owner shall have a right of action against Unit Owners and any aggrieved Unit Owner shall have a right of action against the Association for failure to comply with the provisions of this Declaration, the By-Laws and the Rules and Regulations, and decisions of the Association made pursuant to authority granted to the Association in this Declaration and the By-Laws.
- 13.5 Management and Other Agreements. Any management agreement between the Declarant or the Association and a professional manager or any other agreement providing for services of the sponsor or Declarant shall be terminable by either party thereto without cause and without payment of a termination fee upon not more than thirty (30) days' prior written notice and shall not exceed a term of three (3) years, subject to renewal by the consent of both parties.
- 13.6 Right of First Refusal. The right of a Unit Owner to sell, transfer, mortgage or otherwise convey his interest in his Unit shall not be subject to any right of first refusal.
- 13.7 Consent of First Mortgagees. This Section 13.7 shall be effective only if, at the time this Section would apply, at least one Unit is subject to mortgage financing.

Any decision to terminate the Condominium for reasons other than substantial destruction or condemnation of the property shall require the prior written consent of Eligible Mortgage Holders, as defined in Section 13.9 hereof, representing at least 67% of the votes allocated to Units subject to First Mortgages held by Eligible Mortgage Holders, or such greater requirements specified by the Act.

Any amendment to the Declaration or By-Laws which materially changes any of the following shall require the prior written consent of Unit Owners holding at least 67% of the total votes in the Association and of Eligible Mortgage Holders representing at least 51% of the votes allocated to Units subject to First Mortgages held by Eligible Mortgage Holders, or such greater requirements specified by the Act or hereunder:

- a) voting rights;
- b) assessments, assessment liens or subordination of such liens;
- c) reserves for maintenance, repair and replacement of Common Elements;
- d) responsibility for maintenance and repairs;
- e) reallocation of interests in the Common Elements or Limited Common Elements or rights to their use;
- f) boundaries of any Unit;
- g) convertibility of Units into Common Elements or Common Elements into Units;
- h) expansion or contraction of the Condominium or the addition, annexation or withdrawal of property to or from the Condominium;
- i) insurance or fidelity bonds;
- j) leasing of Units;
- k) imposition of any restrictions on a Unit Owner's right to sell, transfer or otherwise convey his Unit;
- l) a decision by the Association to establish self-management when professional management had been required previously by any Eligible Mortgage Holder;
- m) restoration or repair of the Condominium (after damage or destruction or partial condemnation) in a manner other than that specified in this Declaration or the By-Laws;
- n) any action to terminate the legal status of the Condominium after substantial damage or destruction or condemnation; or
- o) any provisions that expressly benefit First Mortgagees or insurers or guarantors of First Mortgages.

An addition or amendment to the Declaration or By-Laws shall not be considered material if it is for the purpose of correcting technical or typographical errors, or for clarification only.

13.8 Consent of First Mortgagees or Unit Owners. This Section 13.8 shall be effective only if, at the time this Section would apply, at least one Unit is subject to mortgage financing.

Unless First Mortgagees holding at least 66 2/3% of the votes allocated to First Mortgagees except higher percentages as are required by law, of the First Mortgagees (based upon one vote for each First Mortgage owned) and Unit Owners (other than a Declarant) holding at least 66 2/3% of the total votes in the Association have given their

prior written approval, or such greater requirements specified in the Act or hereunder have been satisfied, the Association shall not be entitled to:

- a) by act or omission, seek or abandon or terminate the Condominium;
 - b) change the pro-rata interest or obligations of any Unit for the purpose of:
 - (i) levying assessments or charges or allocating distributions of hazard insurance proceeds or condemnation awards, or
 - (ii) determining the pro-rata share of ownership of each Unit in the Common Elements;
 - c) partition or subdivide any Unit;
 - d) except in the case of any addition of the Additional Real Estate pursuant to the provisions hereof, by act or omission, seek to abandon, partition, subdivide, encumber, sell or transfer the Common Elements. (The granting of easements for public utilities or for other public purposes consistent with the intended use of the Common Elements shall not be deemed a transfer within the meaning of this clause.);
 - e) use hazard insurance proceeds for losses to any part of the Condominium (whether to Units or to Common Elements) for other than repair, replacement, or reconstruction thereof subject to Article IX and Section 6.1 of Article VIII hereof.
- 13.9 Notice. Each first Mortgagee and each insurer or guarantor of a First Mortgage, upon written request stating its name and address and describing the Unit encumbered by the First Mortgage, held, insured or guaranteed, shall be entitled to timely written notification by the Association of (i) any proposed action which requires consent of a specified percentage of First Mortgagees; (ii) any condemnation or casualty loss that affects either a material portion of the Condominium or the Unit securing its First Mortgage; (iii) any 60-day delinquency in the payment of assessments or charges owed by the Unit Owner of the Unit on which the First Mortgagee held its First Mortgage or in the performance of any obligation under this Declaration or the By-Laws by said Unit Owner; or (iv) any lapse, cancellation or material modification of any insurance policy or fidelity bond maintained by the Association. Each First Mortgagee who has requested the Association to notify it of any proposed action that requires the consent of a specified percentage of Eligible Mortgage Holders shall be considered an "Eligible Mortgage Holder." With respect only to non-material amendments (which excludes items (a) to (o) of Section 13.7), such as for the correction of technical errors or for clarification, any First Mortgagee who receives a written request by the Association, or any Unit Owner, to approve an addition or amendment to the

Association, or any Unit Owner, to approve an addition or amendment to the Declaration or By-Laws who does not deliver or post to the requesting party a negative response within 30 days shall be deemed to have approved such request.

- 13.10 Assessments. Assessments shall be due and payable in monthly installments. As provided in Article VI of the By-Laws and as legally required by Section 82.112 of the Act, Declarant shall pay all accrued expenses of the Condominium until assessments are levied against the Units. An assessment shall be deemed levied against a Unit upon the giving of notice by the Board to a member of the Association who is a Unit Owner of that Unit. Unit Owners shall have no obligation to pay monthly assessments until an assessment is levied.
- 13.11 Rights of First Mortgagee: Insurance Proceeds or Condemnation Awards. With respect to First Mortgages held by or for the benefit of First Mortgagees, no provision of this Declaration or the By-Laws shall be deemed to give a Unit Owner or any other party, priority over any rights of a First Mortgagee pursuant to its First Mortgage on said Unit Owner's Unit, in the case of a distribution to said Unit Owner of insurance proceeds or condemnation awards for losses to or a taking of Units and/or Common Elements.
- 13.12 Additional Real Estate: Consent of Administrator: Common Element Interests: Reallocation. In the event any First Mortgages are guaranteed by the Veterans Administration, the Additional Real Estate may not be added to the Condominium without the prior written consent of the Administrator of the Veterans Administration. If the Additional Real Estate is added, the ownership interest in the Common Elements and the liability for Common Expenses for each Unit shall be reallocated on the basis of equality in proportion to each Unit relationship to the total number of Units and each Unit shall continue to have one vote. The effective date for said reallocation shall be the date of recordation of the amendment to this Declaration, which document shall comply with the provisions of the Act. The effective date for the assignment of assessments to the Units added to the Condominium shall be the date the Board levies an assessment against said Units. All improvements intended to be located within any portion of the Additional Real Estate added to the Condominium shall be substantially completed prior to the addition of said portion of the Additional Real Estate.

ARTICLE XIV
General Provisions

- 14.1 Conflict With the Act; Severability. Should any of the terms, conditions, provisions, paragraphs, or clauses of this Declaration conflict with any provisions of the Act, the provisions of the Act shall control unless the Act permits the Declaration to override the Act, in which event the Declaration shall control. The invalidity of any covenant, restriction, condition, limitation, provision, paragraph

any person or circumstance, shall not impair or affect in any manner the validity, enforceability or effect of the rest of this Declaration, or the application of any such covenant, restriction, condition, limitation, provision, paragraph or clause to any other person or circumstance.

- 14.2 Interpretation of Declaration. Whenever appropriate singular may be read as plural, plural may be read as singular, and the masculine gender may be read as the feminine or neuter gender. Compound words beginning with the prefix "here" shall refer to this entire Declaration and not merely to the part in which they appear.
- 14.3 Captions. The captions herein are only for convenience and reference and do not define, limit or describe the scope of this Declaration, or the intent of any provision.
- 14.4 Exhibits. Exhibits "A", "B", "C", "D" and "E" attached hereto are hereby made a part hereof.
- 14.5 Invalidity. The invalidity of any provision of this Declaration shall not be deemed to impair or affect in any manner the validity or enforceability or effect of the remainder of this Declaration, and in such event, all of the other provisions of this Declaration shall continue in full force and effect as if such invalid provision had never been included herein.
- 14.6 Waiver. No provision of this Declaration shall be deemed to have been abrogated or waived by reason of any failure to enforce the same, irrespective of the number of violations or breaches which may occur.
- 14.7 Law Controlling. This Declaration shall be construed and controlled by and under the laws of the State of Texas.

IN WITNESS WHEREOF, Declarant hereby executes this Declaration by and through its authorized representatives on the day and year first above written.

RIVER RIDGE TOWNHOMES, LTD.,
a Texas limited partnership

By: SKYCO MANAGEMENT, L.L.C.,
a Texas limited liability company,
its General Partner

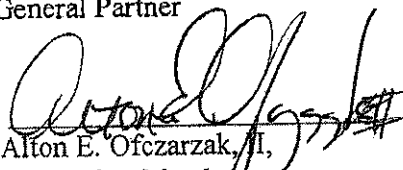
By: 
Alton E. Ofczarzak, II,
Managing Member

THE STATE OF TEXAS §

COUNTY OF BRAZOS §

I, Carol Pabst Ransom, a Notary Public, do hereby certify that Alton E. Ofczarzak, II, Managing Member of Skyko Management, L.L.C., a Texas limited liability company, acting in its capacity as General Partner of River Ridge Management, Ltd., a Texas limited partnership, personally appeared before me on this day and acknowledged the execution of the foregoing instrument.

WITNESS my hand and official seal on this 16th day of November, 2015.

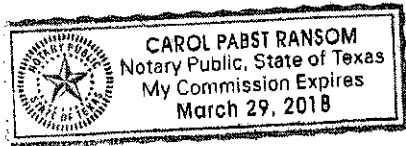

Carol Pabst Ransom
Notary Public, State of Texas

EXHIBITS TO BE ATTACHED TO DECLARATION

- | | |
|-------------|--------------------------|
| Exhibit "A" | Property, Plat and Plans |
| Exhibit "B" | Percent Interest Chart |
| Exhibit "C" | Encumbrances |
| Exhibit "D" | Certificate of Formation |
| Exhibit "E" | By-Laws |

LENDER CONSENT

Guaranty Bank & Trust, N.A. ("Guaranty Bank"), the Lien holder on the Property described in this Declaration of Copper Creek Condos ("Declaration"), does hereby consent to the attached Declaration and agrees that a foreclosure of Guaranty Bank's Lien on any Property described in the Declaration will not terminate or void the Declaration.

WITNESS this 16th day of November, 2015.

GUARANTY BANK & TRUST, N.A.

By: S. F. Bledsoe

THE STATE OF TEXAS §

COUNTY OF Brazos §

This instrument was acknowledged before me on this the 16th day of November, 2015, by Steve Bledsoe, Sr. Vice President of GUARANTY BANK & TRUST, N.A., on behalf of said bank.

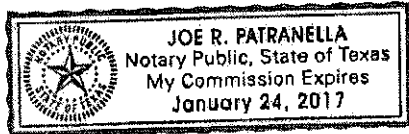



Notary Public, State of Texas
My Commission Expires: 1-24-17

EXHIBIT "A"
TO
DECLARATION OF COPPER CREEK CONDOS
PROPERTY, PLATS AND PLANS

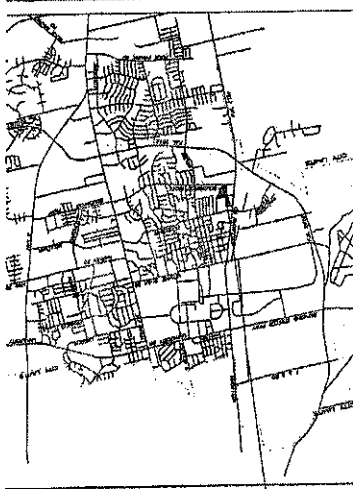

LEGEND OF SYMBOLS

Symbol	DESCRIPTION
Circle with dot	Proposed Lot
Circle with horizontal line	Proposed Right-of-Way
Circle with vertical line	Proposed Easement
Circle with diagonal line	Proposed Encroachment
Circle with cross	Proposed Utility
Circle with triangle	Proposed Survey
Circle with square	Proposed Structure
Circle with diamond	Proposed Fence
Circle with star	Proposed Monument
Circle with plus	Proposed Survey
Circle with asterisk	Proposed Survey
Circle with dot	Proposed Survey

PROJECT LOCATION

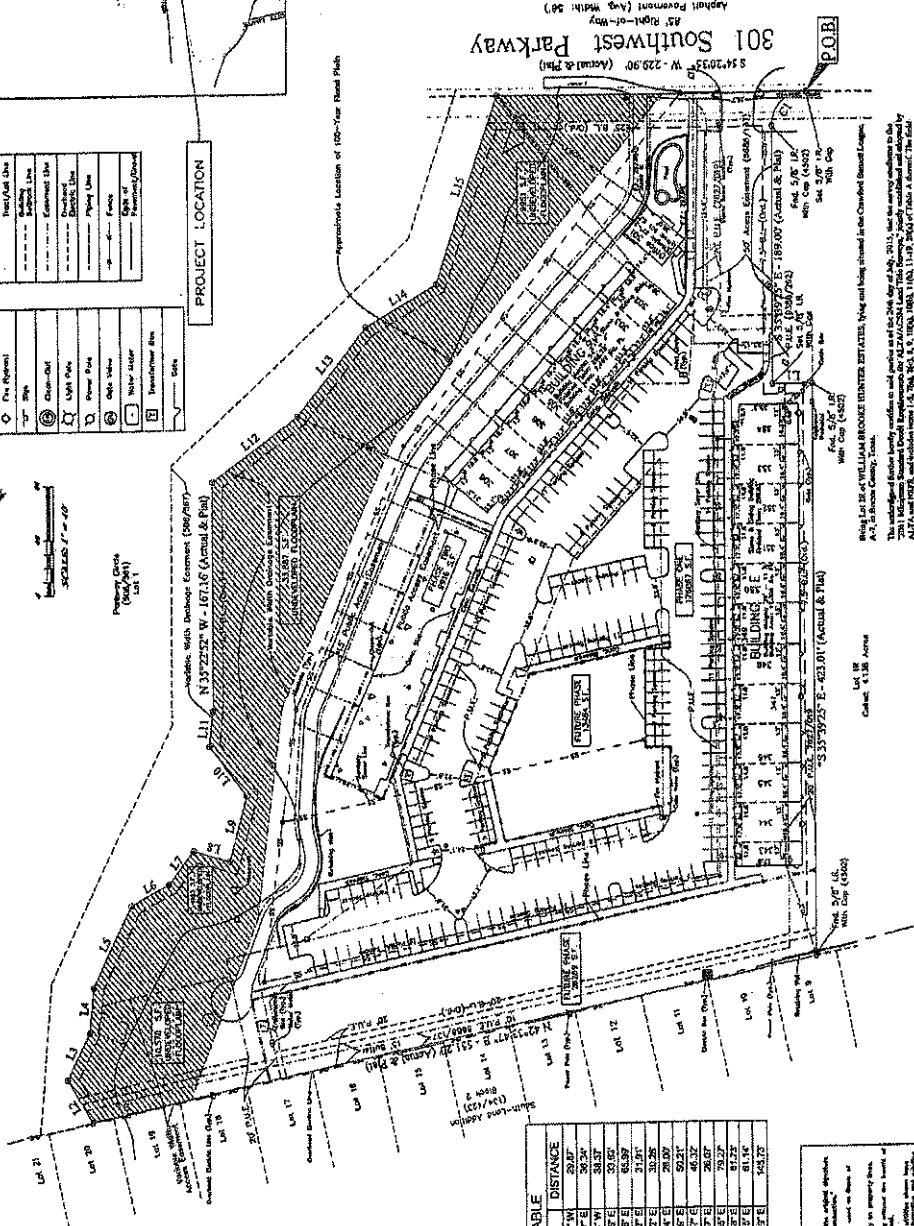

LINE	BEARING	DISTANCE
L1	S 54°20'15" W	29.87'
L2	S 69°37'17" E	30.29'
L3	N 08°25'08" W	30.29'
L4	S 69°37'17" E	30.29'
L5	S 69°37'17" E	30.29'
L6	N 15°28'00" E	31.97'
L7	N 07°22'52" E	30.29'
L8	N 71°17'14" E	29.87'
L9	S 29°57'16" E	30.29'
L10	S 71°42'50" E	30.29'
L11	N 15°28'00" E	31.97'
L12	N 15°28'00" E	31.97'
L13	N 15°28'00" E	31.97'
L14	N 24°17'07" E	61.14'
L15	S 17°27'15" E	545.72'

CURVE	RADIUS	DELTA	TANGENT LENGTH	CHORD	I.C.
C1	25.00'	80°00'00"	21.00'	38.07'	N 39°39'52" E 35.36'

NOTES:
 1. This plat is based on the original plat.
 2. The area shown is subject to the rights of adjacent owners.
 3. The area shown is subject to the rights of adjacent owners.
 4. The area shown is subject to the rights of adjacent owners.
 5. The area shown is subject to the rights of adjacent owners.
 6. The area shown is subject to the rights of adjacent owners.
 7. The area shown is subject to the rights of adjacent owners.
 8. The area shown is subject to the rights of adjacent owners.
 9. The area shown is subject to the rights of adjacent owners.
 10. The area shown is subject to the rights of adjacent owners.



Garrett Engineering, Inc.
 Registered Professional Engineer
 License No. 3877

ALTA/JCSM LAND TITLE SURVEY OF LOT 2R (6.33 Acres) WILLIAM BRODKE HUNTER ESTATES GRANTFORD BURNETT LEASE ABSTRACT NO. 7 301 SOUTHWEST PARKWAY COLLEGE STATION, BRAZOS COUNTY TEXAS

APPROXIMATE LOCATION OF 100'-WIDE ROAD PLAT

54°20'15" W - 229.90' (Actual & Plat)
 85° Right-of-Way (Avg. Width: 80')

POB

ALTA/JCSM LAND TITLE SURVEY OF LOT 2R (6.33 Acres) WILLIAM BRODKE HUNTER ESTATES GRANTFORD BURNETT LEASE ABSTRACT NO. 7 301 SOUTHWEST PARKWAY COLLEGE STATION, BRAZOS COUNTY TEXAS

2:\jcs\survey\jobs\Survey-Job 2015\15-07015-075.dwg

ALSO SEE: SOUTH WEST PARKWAY

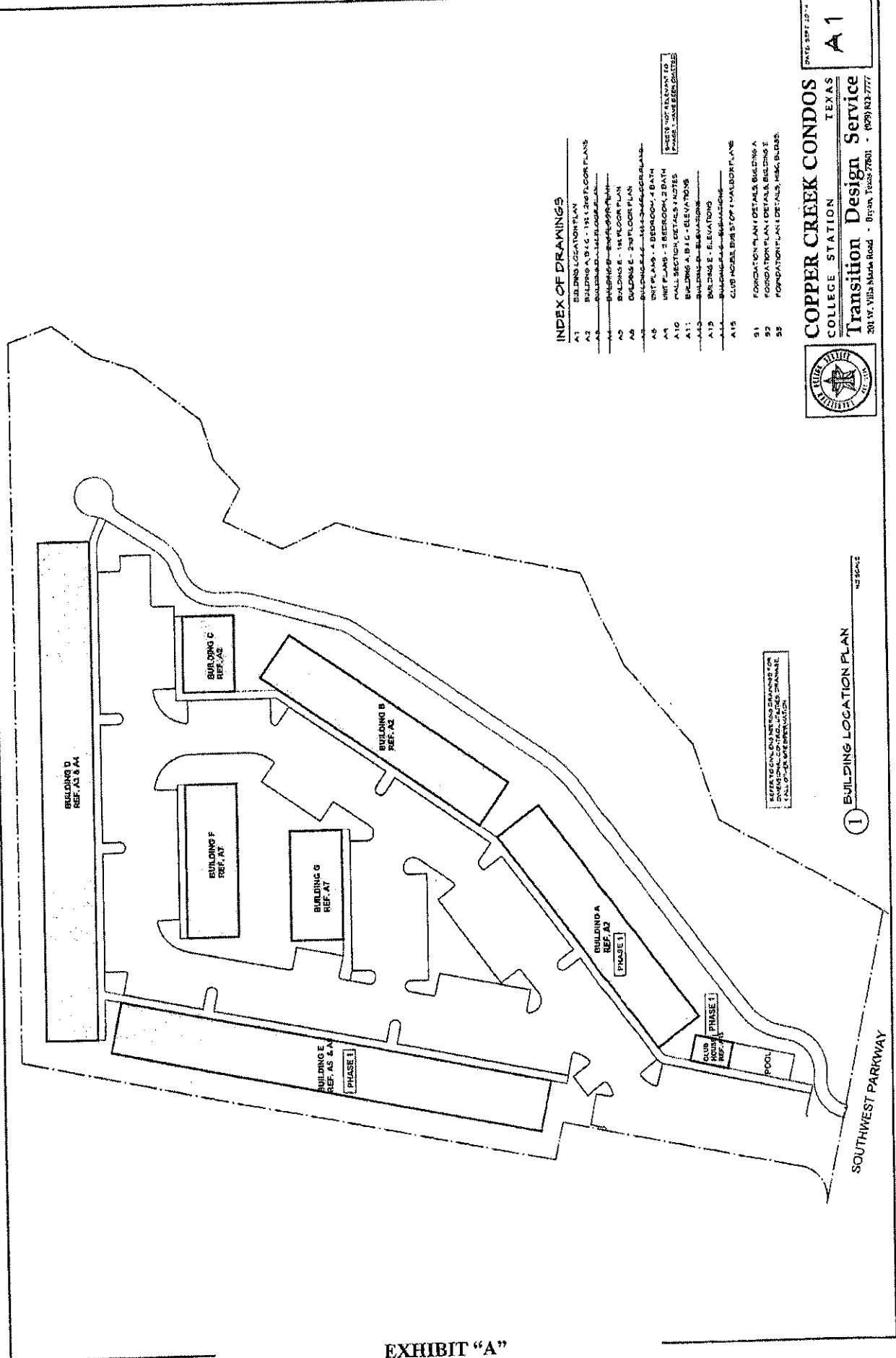

INDEX OF DRAWINGS

- A1 BUILDING LOCATION PLAN
- A2 BUILDING A, B, C - 1ST FLOOR PLANS
- A3 BUILDING A, B, C - 2ND FLOOR PLANS
- A4 BUILDING D - 1ST FLOOR PLAN
- A5 BUILDING E - 1ST FLOOR PLAN
- A6 BUILDING E - 2ND FLOOR PLAN
- A7 BUILDING F - 1ST FLOOR PLAN
- A8 BUILDING G - 1ST FLOOR PLAN
- A9 UNIT PLANS - 4 BEDROOM, 4 BATH
- A10 UNIT PLANS - 2 BEDROOM, 2 BATH
- A11 WALL SECTION DETAILS & NOTES
- A12 BUILDING A, B, C - ELEVATIONS
- A13 BUILDING D - ELEVATIONS
- A14 BUILDING E - ELEVATIONS
- A15 CLUB HOUSE DETAIL OF FLOOR PLAN
- S1 FOUNDATION PLAN & DETAILS BUILDING A
- S2 FOUNDATION PLAN & DETAILS BUILDING B
- S3 FOUNDATION PLAN & DETAILS BUILDING C
- S4 FOUNDATION PLAN & DETAILS BUILDING D
- S5 FOUNDATION PLAN & DETAILS BUILDING E

SEE'S REFERENCE TO THESE DRAWINGS FOR PHASE 1 AND PHASE 2

DATE: 03/19/04
A 1

COPPER CREEK CONDOS
COLLEGE STATION TEXAS
Transition Design Service
20 W. VERA MARIA Road • Bryan, Texas 77801 • (937) 831-7777



1 BUILDING LOCATION PLAN

REFER TO CIVIL AND MECHANICAL DRAWINGS FOR PHASE 1 AND PHASE 2

EXHIBIT "A"

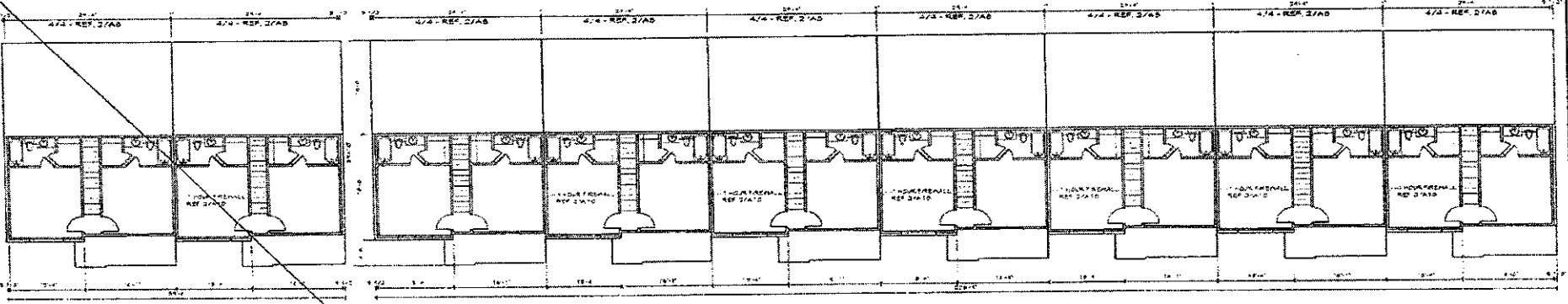

④ BLDG. C - 2nd FLOOR PLAN PHASE B

② BLDG. A & B - 2nd FLOOR PLAN BLDG. A - PHASE 1

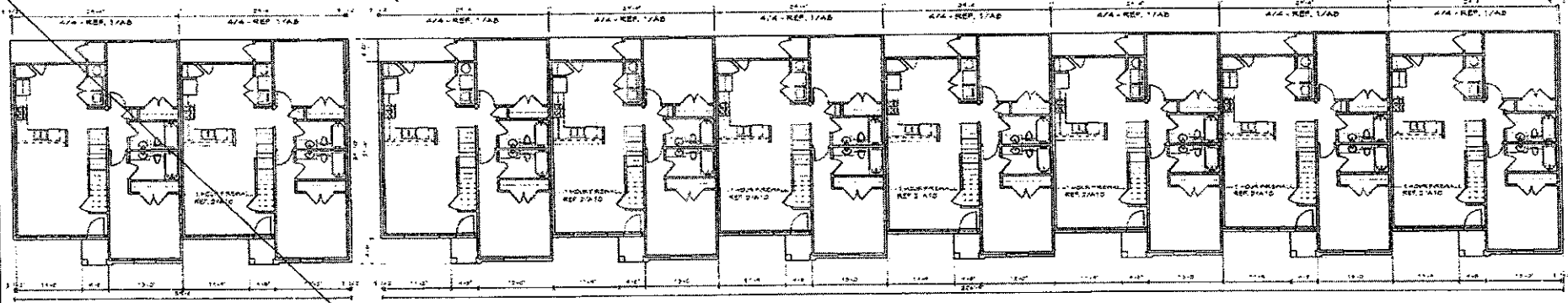

③ BLDG. C - 1st FLOOR PLAN PHASE B

① BLDG. A & B - 1st FLOOR PLAN BLDG. A - PHASE 1

BLDG AREA: 2081 SF
 RELATED AREA: 8278 SF

RELATED AREA INDICATED IS CALCULATED TO OUTSIDE FACE OF STUDO & DOES NOT INCLUDE BR OR VENER, PORCHES OR BALCONIES

BLDG AREA: 1096 SF
 RELATED AREA: 7206 SF

RELATED AREA INDICATED IS CALCULATED TO OUTSIDE FACE OF STUDO & DOES NOT INCLUDE BR OR VENER, PORCHES OR BALCONIES



COPPER CREEK CONDOS
 COLLEGE STATION TEXAS
Transition Design Service
 301 W. Villa Maria Road • Bryan, Texas 77801 • (979) 832-7777

DATE: SEPT 20 14
A2

DATE: 08/11/11
BY: [Signature]

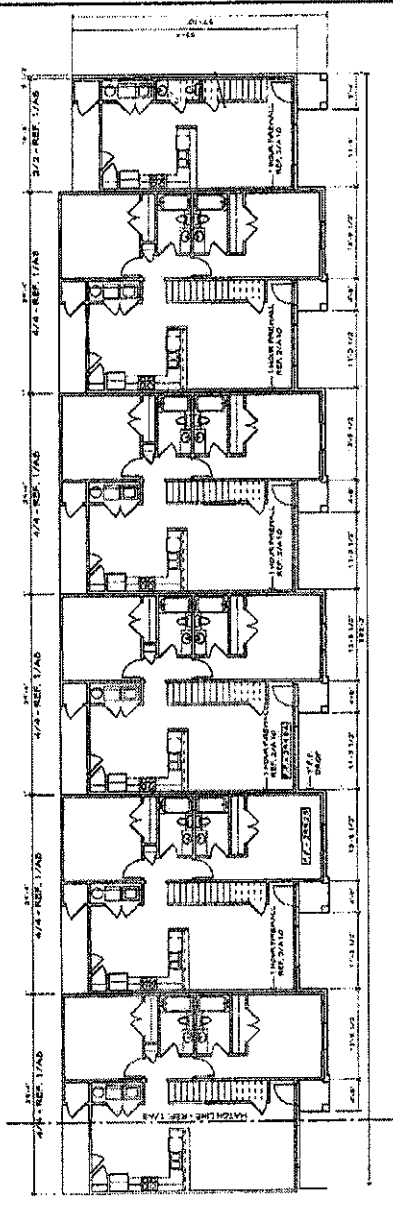

② BLDG. E - 1st FLOOR PLAN PHASE 1

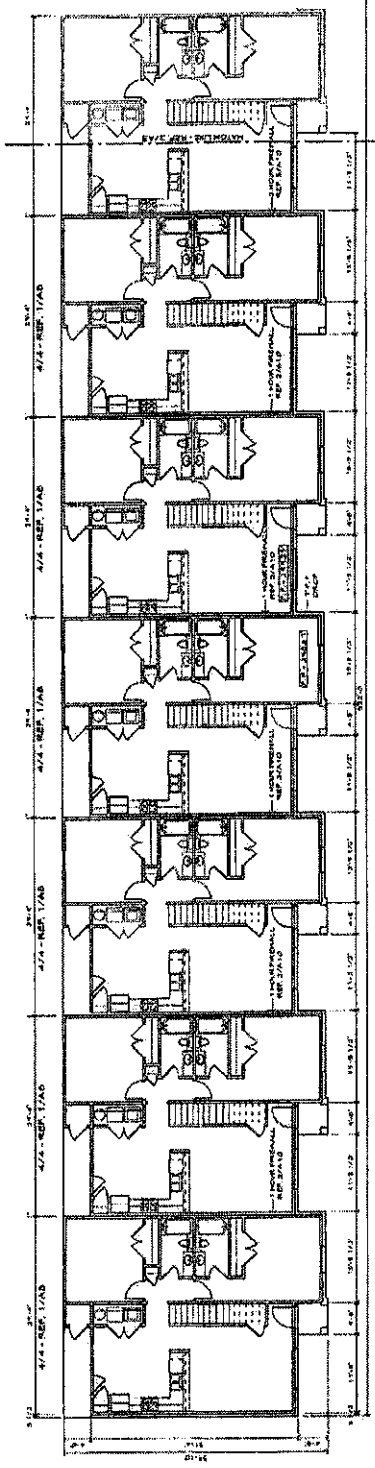

① BLDG. E - 1st FLOOR PLAN PHASE 1

DATE: JAN 2011
SABANCA TEXAS
10110100-20000-01

DATE: JAN 2011
Bk 01
CR 1304
A B

COPPER CREEK CONDOS
COLLEGE STATION
TEXAS
Transition Design Service
201 W. 7th Main Road • Bryan, Texas 77808 • (979) 822-7777



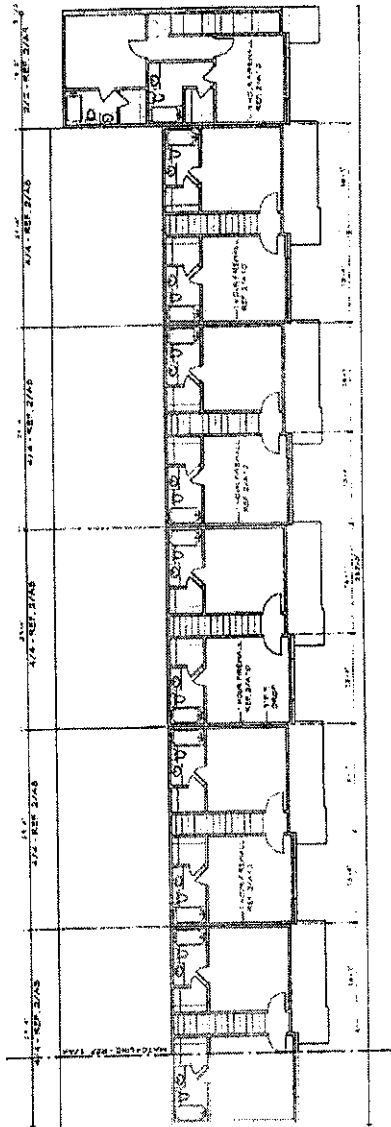

PHASE 1

2 BLDG. E - 2nd FLOOR PLAN

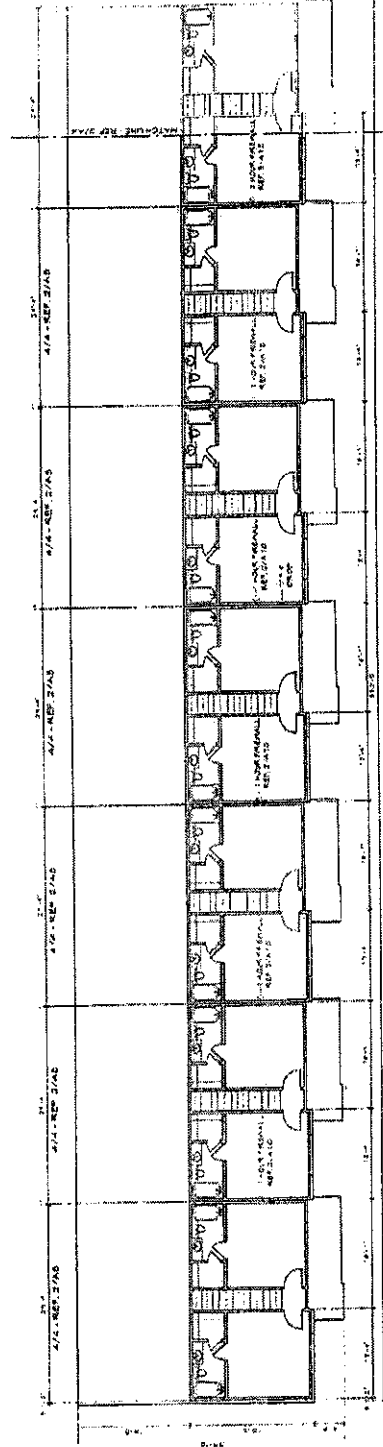

PHASE 1

1 BLDG. E - 2nd FLOOR PLAN



COPPER CREEK CONDOS
COLLEGE STATION
TEXAS
Transition Design Service
301 W. WEBB ROAD • Bryan, Texas 77801 • (979) 824-7777

A6

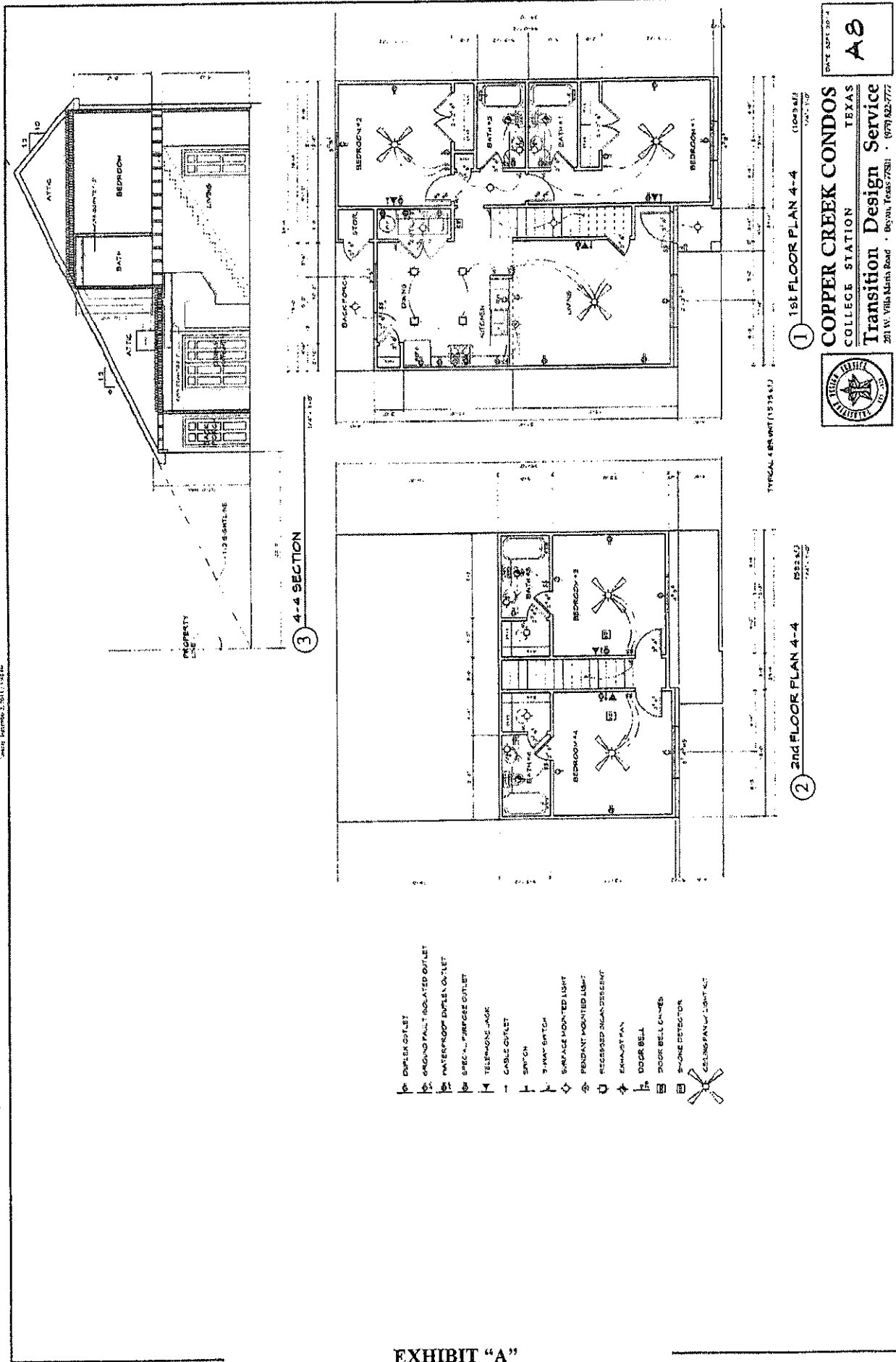

DATE: 08/13/04
A8

COPPER CREEK CONDOS
 COLLEGE STATION TEXAS
Transition Design Service
 201 W. Villa Martha Road • Baytown, Texas 77521 • (979) 842-7772



AS PER PLAN 2-2
 LAYOUT, REVISIONS 2, 2017/11/14/16

- ◇ SURFACE MOUNTED LIGHT
- ◇ PENDANT MOUNTED LIGHT
- ◇ RECESSED INCANDESCENT
- ◇ RECESSED INCANDESCENT
- ◇ EXHAUST FAN
- ◇ DOOR BELL
- ◇ DOOR BELL CHIMES
- ◇ SMOKE DETECTOR
- ◇ CEILING FAN W/ LIGHT KIT
- ◇ DUPLEX OUTLET
- ◇ GROUND FAULT INTERRUPTER OUTLET
- ◇ WATERPROOF DUPLEX OUTLET
- ◇ SPECIAL PURPOSE OUTLET
- ◇ TELEPHONE JACK
- ◇ CABLES OUTLET
- ◇ SWITCH
- ◇ 3-WAY SWITCH

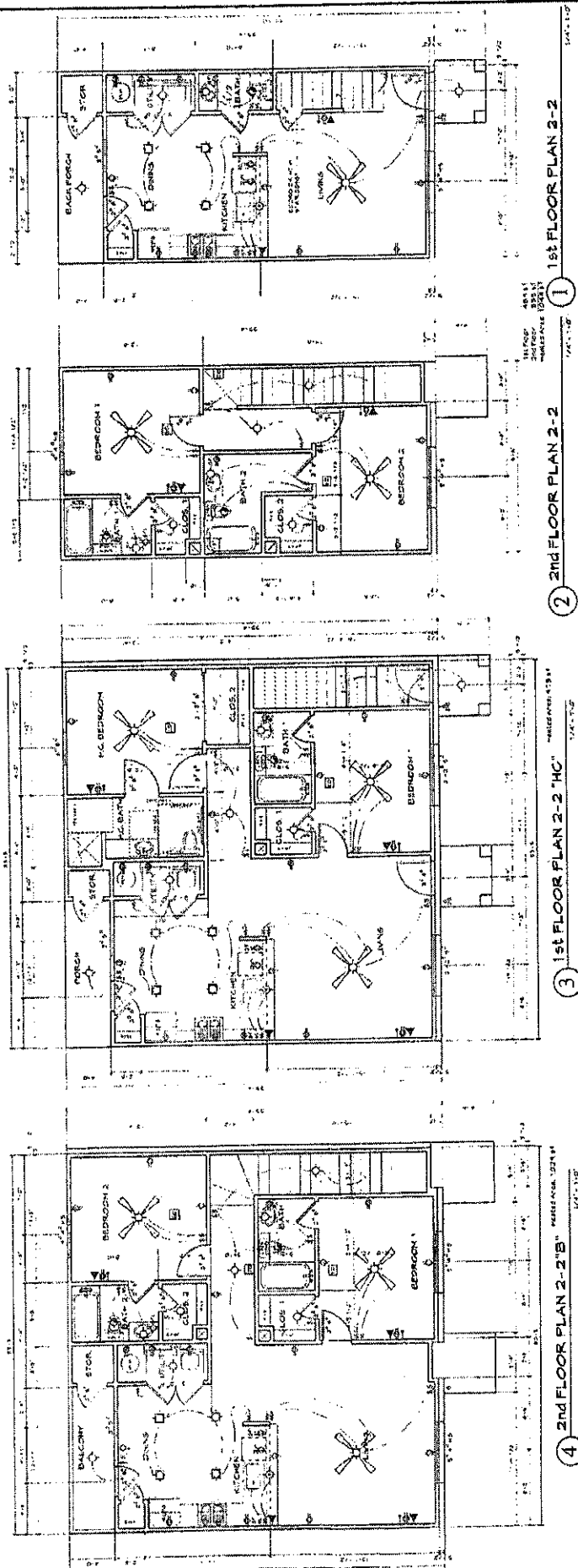

1 1st FLOOR PLAN 2-2
2 2nd FLOOR PLAN 2-2
3 1st FLOOR PLAN 2-2 HC
4 2nd FLOOR PLAN 2-215B

COPPER CREEK CONDOS
 COLLEGE STATION TEXAS
Transition Design Service
 201 W. V&B, Manda Road • Bryan, Texas 77803 • (979) 622-7177

DATE REVISION
A

EXHIBIT "A"

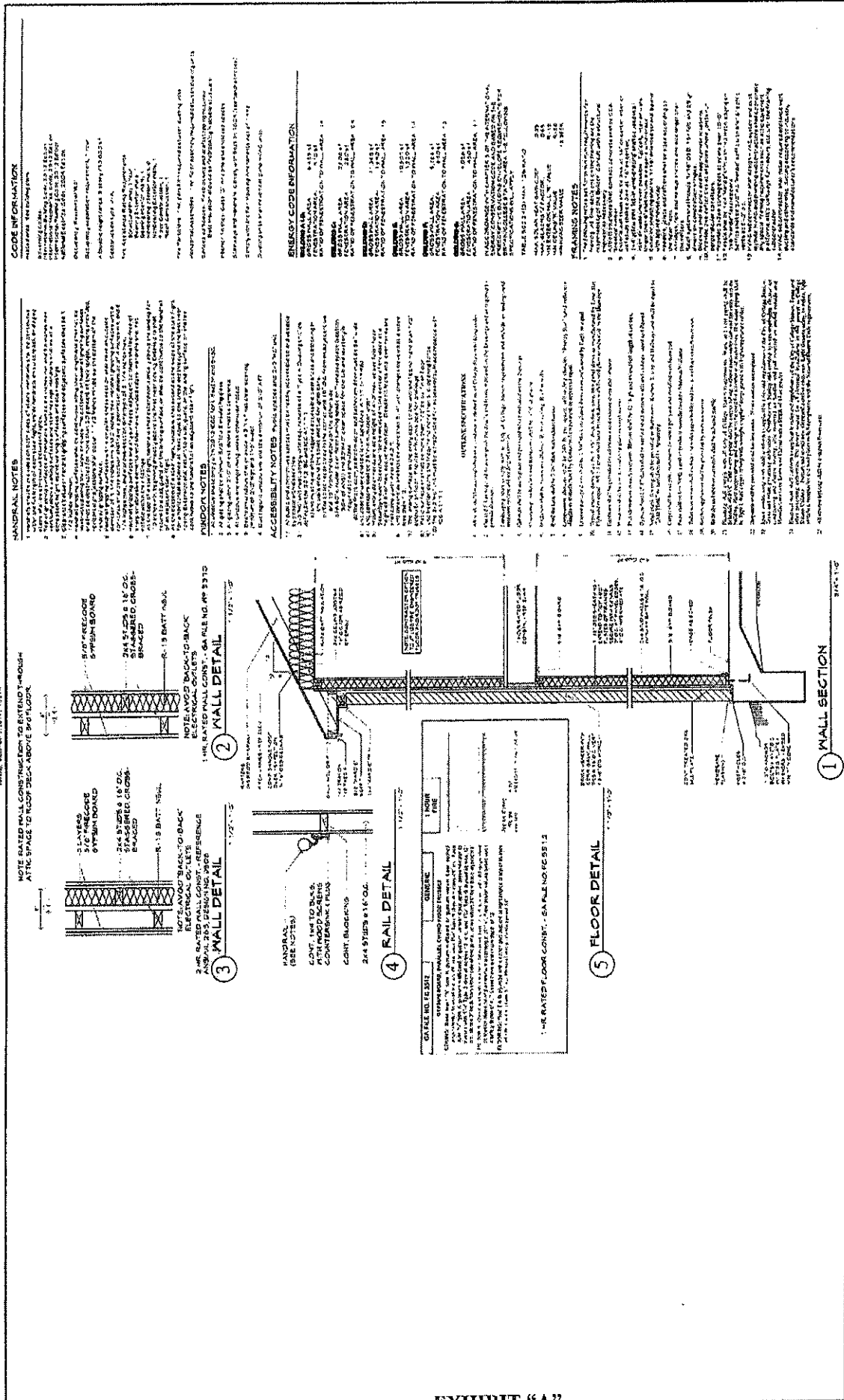

HANDRAIL NOTES

1. HANDRAILS SHALL BE INSTALLED TO EXTEND THROUGH AT THE SPACE TO ROOF DECK ABOVE 50' FLOOR.
2. HANDRAILS SHALL BE INSTALLED TO EXTEND THROUGH AT THE SPACE TO ROOF DECK ABOVE 50' FLOOR.
3. HANDRAILS SHALL BE INSTALLED TO EXTEND THROUGH AT THE SPACE TO ROOF DECK ABOVE 50' FLOOR.
4. HANDRAILS SHALL BE INSTALLED TO EXTEND THROUGH AT THE SPACE TO ROOF DECK ABOVE 50' FLOOR.
5. HANDRAILS SHALL BE INSTALLED TO EXTEND THROUGH AT THE SPACE TO ROOF DECK ABOVE 50' FLOOR.

ACCESSIBILITY NOTES

1. ACCESSIBILITY COMPLIANCE SHALL BE IN ACCORDANCE WITH THE 2010 INTERNATIONAL BUILDING CODE (IBC) AND THE 2010 INTERNATIONAL ACCESSIBILITY AND MOBILITY ACT (ADA).
2. HANDRAILS SHALL BE INSTALLED TO EXTEND THROUGH AT THE SPACE TO ROOF DECK ABOVE 50' FLOOR.
3. HANDRAILS SHALL BE INSTALLED TO EXTEND THROUGH AT THE SPACE TO ROOF DECK ABOVE 50' FLOOR.
4. HANDRAILS SHALL BE INSTALLED TO EXTEND THROUGH AT THE SPACE TO ROOF DECK ABOVE 50' FLOOR.
5. HANDRAILS SHALL BE INSTALLED TO EXTEND THROUGH AT THE SPACE TO ROOF DECK ABOVE 50' FLOOR.

FRAMING NOTES

1. ALL FRAMING SHALL BE IN ACCORDANCE WITH THE 2010 INTERNATIONAL BUILDING CODE (IBC).
2. ALL FRAMING SHALL BE IN ACCORDANCE WITH THE 2010 INTERNATIONAL BUILDING CODE (IBC).
3. ALL FRAMING SHALL BE IN ACCORDANCE WITH THE 2010 INTERNATIONAL BUILDING CODE (IBC).
4. ALL FRAMING SHALL BE IN ACCORDANCE WITH THE 2010 INTERNATIONAL BUILDING CODE (IBC).
5. ALL FRAMING SHALL BE IN ACCORDANCE WITH THE 2010 INTERNATIONAL BUILDING CODE (IBC).

ENERGY CODE INFORMATION

ALL ENERGY EFFICIENCY REQUIREMENTS SHALL BE IN ACCORDANCE WITH THE 2010 INTERNATIONAL ENERGY CONSERVATION CODE (IECC).

PERMITS

ALL PERMITS SHALL BE OBTAINED PRIOR TO COMMENCEMENT OF WORK.

DATE: 08/10/2011

A 10

COPPER CREEK CONDOS
 COLLEGE STATION, TEXAS
Transition Design Service
 301 W. Villa Blanca Road - Baytown, Texas 77601 - (979) 829-7777

SPAN TABLE		HEADERS SCHEDULE		RAILS SCHEDULE	
SPAN	SECTION	SPAN	SECTION	SPAN	SECTION
10'-0"	10'-0"	4'-0"	4'-0"	1'-0"	1'-0"
12'-0"	12'-0"	6'-0"	6'-0"	1'-0"	1'-0"
14'-0"	14'-0"	8'-0"	8'-0"	1'-0"	1'-0"
16'-0"	16'-0"	10'-0"	10'-0"	1'-0"	1'-0"
18'-0"	18'-0"	12'-0"	12'-0"	1'-0"	1'-0"
20'-0"	20'-0"	14'-0"	14'-0"	1'-0"	1'-0"
22'-0"	22'-0"	16'-0"	16'-0"	1'-0"	1'-0"
24'-0"	24'-0"	18'-0"	18'-0"	1'-0"	1'-0"
26'-0"	26'-0"	20'-0"	20'-0"	1'-0"	1'-0"
28'-0"	28'-0"	22'-0"	22'-0"	1'-0"	1'-0"
30'-0"	30'-0"	24'-0"	24'-0"	1'-0"	1'-0"

SPAN TABLE: SPAN TABLE FOR 2x10 JOISTS WITH 16" O.C. SPACING. HEADERS SCHEDULE: HEADERS SCHEDULE FOR 2x10 JOISTS WITH 16" O.C. SPACING. RAILS SCHEDULE: RAILS SCHEDULE FOR 2x10 JOISTS WITH 16" O.C. SPACING.

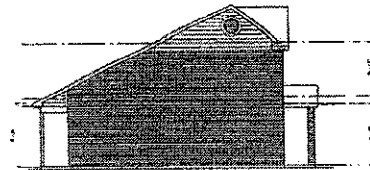

6 BLDG. A, B & C - LEFT SIDE ELEV. 1/8" = 1'-0"

BLDG. A - PHASE 1

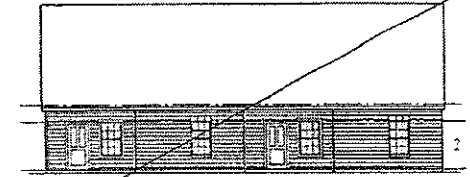

4 BLDG. C - BACK ELEVATION 1/8" = 1'-0"

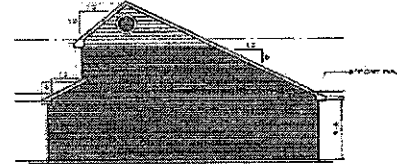

5 BLDG. A, B & C - RIGHT SIDE ELEV. 1/8" = 1'-0"

BLDG. A - PHASE 1

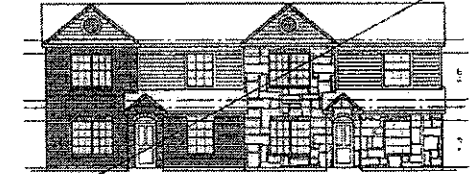

3 BLDG. C - FRONT ELEVATION 1/8" = 1'-0"

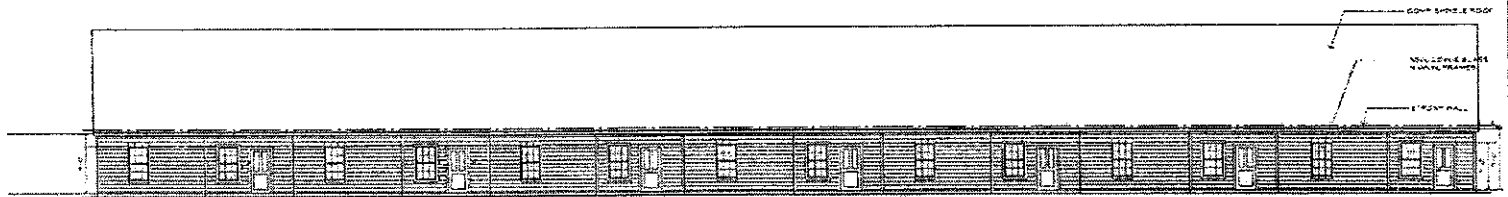

2 BLDG. A & B - BACK ELEVATION 1/8" = 1'-0"

BLDG. A - PHASE 1

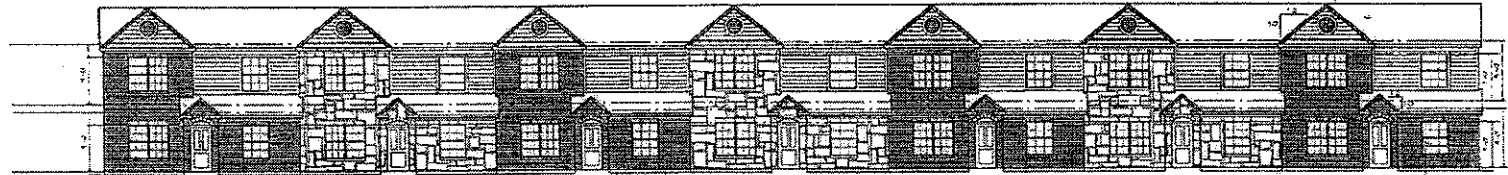

1 BLDG. A & B - FRONT ELEVATION 1/8" = 1'-0"

BLDG. A - PHASE 1



COPPER CREEK CONDOS
COLLEGE STATION TEXAS

Transition Design Service
201 W. Villa Marie Road • Bryan, Texas 77801 • (979) 822-7777

DATE: 09/02/2024
A 11

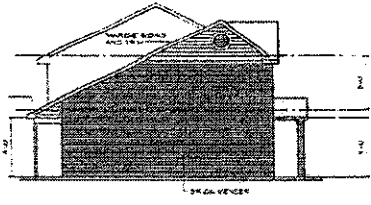

5 BLDG. E - LEFT SIDE ELEV. PHASE 1

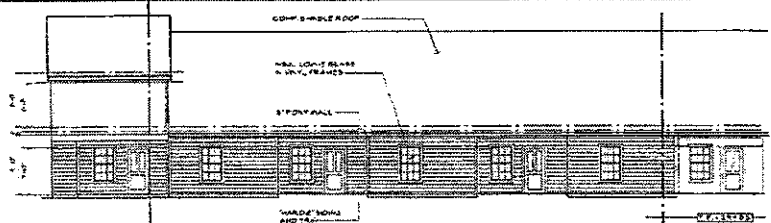

4 BLDG. E - BACK ELEVATION PHASE 1

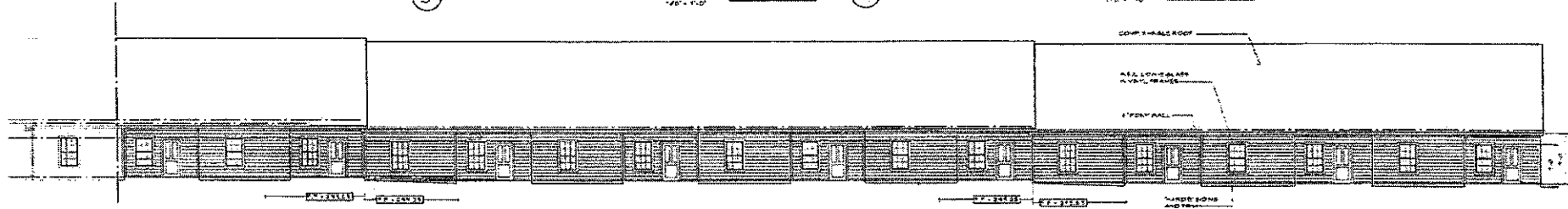

3 BLDG. E - BACK ELEVATION PHASE 1

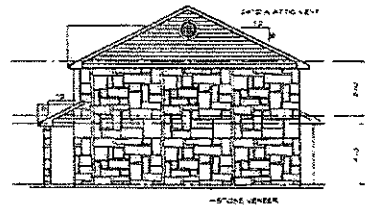

6 BLDG. E - RIGHT SIDE ELEV. PHASE 1

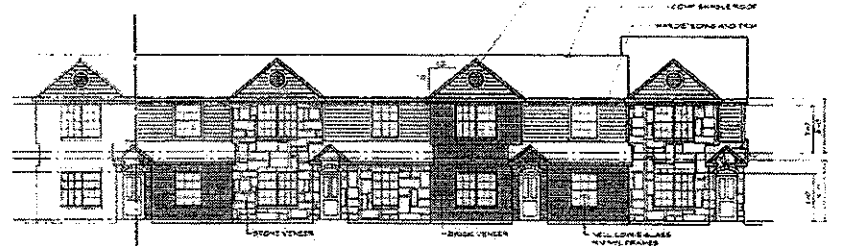

2 BLDG. E - FRONT ELEVATION PHASE 1

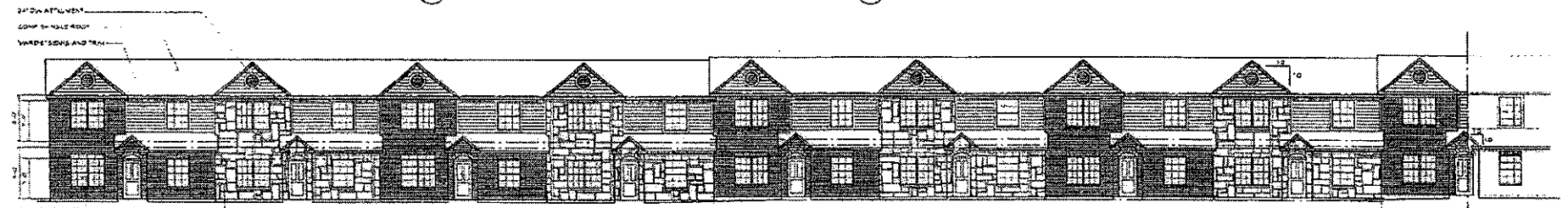

1 BLDG. E - FRONT ELEVATION PHASE 1

EXHIBIT (A)
 01248904 DR 13045



COPPER CREEK CONDOS
 COLLEGE STATION TEXAS
Transition Design Service
 201 W. Villa Maria Road • Bryan, Texas 77801 • (979) 821-7777

DATE: 08/21/08
A 13

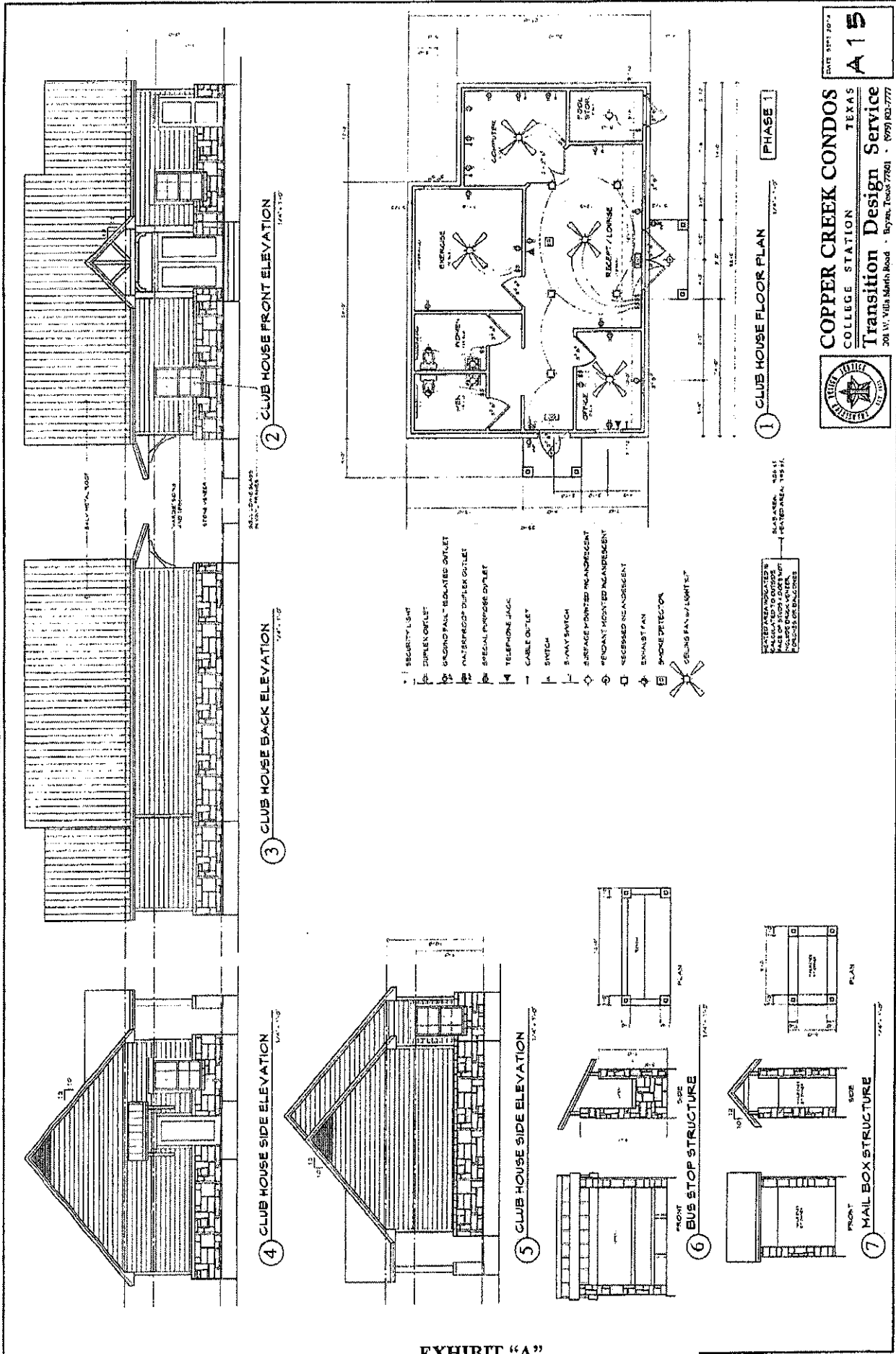

DATE: 08/11/04
A 15
COPPER CREEK CONDOS
 COLLEGE STATION, TEXAS
Transition Design Service
 200 W. Vth. South Road • Bryan, Texas 77801 • (979) 832-7777

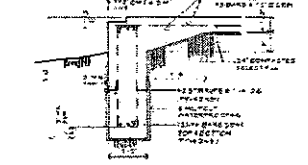
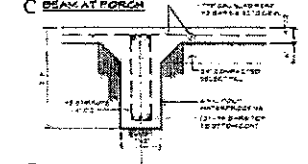
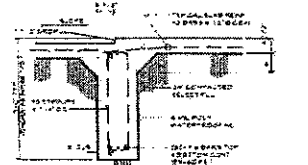
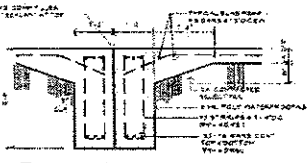
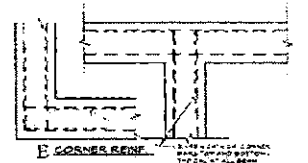

3 FOUNDATION DETAILS

FOUNDATION SPECIFICATIONS

GENERAL:

1. FOUNDATION SHALL BE CONSTRUCTED TO SUPPORT ALL LOADS INCLUDING FUTURE LOADS AS SHOWN ON THE FOUNDATION PLAN.
2. FOUNDATION SHALL BE CONSTRUCTED TO RESIST ALL LATERAL LOADS INCLUDING WIND AND SEISMIC LOADS AS SHOWN ON THE FOUNDATION PLAN.
3. FOUNDATION SHALL BE CONSTRUCTED TO RESIST ALL UPLIFT LOADS INCLUDING WIND AND SEISMIC LOADS AS SHOWN ON THE FOUNDATION PLAN.
4. FOUNDATION SHALL BE CONSTRUCTED TO RESIST ALL SETTLEMENT LOADS INCLUDING WIND AND SEISMIC LOADS AS SHOWN ON THE FOUNDATION PLAN.

CONCRETE:

1. CONCRETE SHALL BE 4000 PSI STRENGTH.
2. CONCRETE SHALL BE PLACED AND FINISHED AS SHOWN ON THE FOUNDATION PLAN.
3. CONCRETE SHALL BE CURED AS SHOWN ON THE FOUNDATION PLAN.
4. CONCRETE SHALL BE PROTECTED FROM WEATHER AS SHOWN ON THE FOUNDATION PLAN.

REINFORCEMENT:

1. REINFORCEMENT SHALL BE #4 BARS.
2. REINFORCEMENT SHALL BE PLACED AS SHOWN ON THE FOUNDATION PLAN.
3. REINFORCEMENT SHALL BE TIED AS SHOWN ON THE FOUNDATION PLAN.
4. REINFORCEMENT SHALL BE DEVELOPED AS SHOWN ON THE FOUNDATION PLAN.

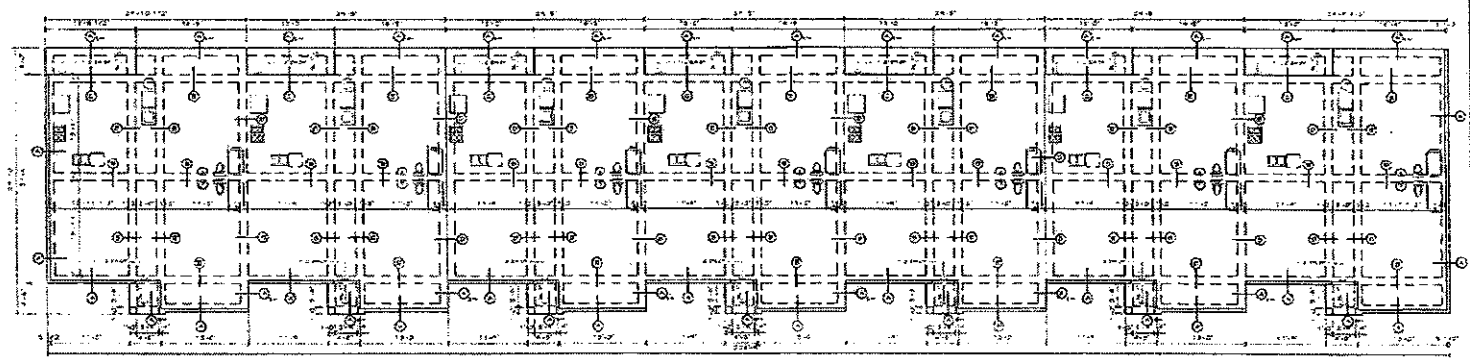

IF ANY OF THE ABOVE INFORMATION IS FOUND TO BE IN ERROR, THE CONTRACTOR SHALL BE RESPONSIBLE FOR CORRECTING THE SAME AT HIS OWN EXPENSE. THE CONTRACTOR SHALL BE RESPONSIBLE FOR OBTAINING ALL NECESSARY PERMITS AND APPROVALS FROM THE LOCAL AUTHORITIES. THE CONTRACTOR SHALL BE RESPONSIBLE FOR OBTAINING ALL NECESSARY INSURANCE AND BONDING. THE CONTRACTOR SHALL BE RESPONSIBLE FOR OBTAINING ALL NECESSARY UTILITIES INFORMATION. THE CONTRACTOR SHALL BE RESPONSIBLE FOR OBTAINING ALL NECESSARY ADJACENT PROPERTY INFORMATION. THE CONTRACTOR SHALL BE RESPONSIBLE FOR OBTAINING ALL NECESSARY ADJACENT PROPERTY INFORMATION.

1 FOUNDATION PLAN BUILDING "A" PHASE 1



COPPER CREEK CONDOS
 COLLEGE STATION TEXAS
Transition Design Service
 301 W. Villa Maria Road • Bryan, Texas 77801 • (979) 832-7777

DATE REVISED:
S1

Doc: BK V01 Pg 208
 11/13/2010 11:18 AM

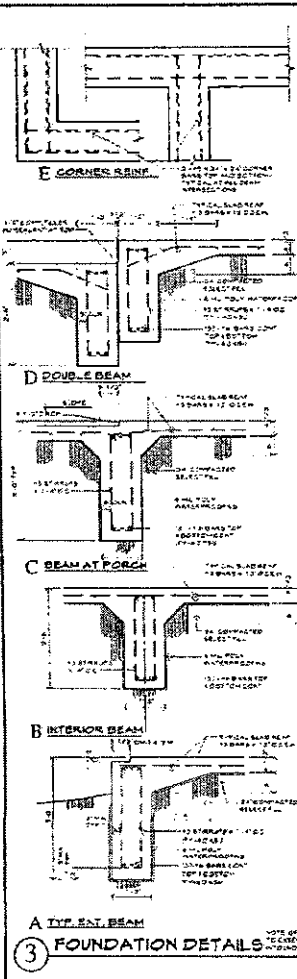

FOUNDATION SPECIFICATIONS

1. ALL FOUNDATION CONSTRUCTION SHALL BE IN ACCORDANCE WITH THE LATEST EDITIONS OF THE INTERNATIONAL BUILDING CODE (IBC) AND THE ACI 318 BUILDING CODE REQUIREMENTS FOR STRUCTURAL CONCRETE.

2. ALL FOUNDATION CONSTRUCTION SHALL BE IN ACCORDANCE WITH THE LATEST EDITIONS OF THE INTERNATIONAL BUILDING CODE (IBC) AND THE ACI 318 BUILDING CODE REQUIREMENTS FOR STRUCTURAL CONCRETE.

3. ALL FOUNDATION CONSTRUCTION SHALL BE IN ACCORDANCE WITH THE LATEST EDITIONS OF THE INTERNATIONAL BUILDING CODE (IBC) AND THE ACI 318 BUILDING CODE REQUIREMENTS FOR STRUCTURAL CONCRETE.

4. ALL FOUNDATION CONSTRUCTION SHALL BE IN ACCORDANCE WITH THE LATEST EDITIONS OF THE INTERNATIONAL BUILDING CODE (IBC) AND THE ACI 318 BUILDING CODE REQUIREMENTS FOR STRUCTURAL CONCRETE.

5. ALL FOUNDATION CONSTRUCTION SHALL BE IN ACCORDANCE WITH THE LATEST EDITIONS OF THE INTERNATIONAL BUILDING CODE (IBC) AND THE ACI 318 BUILDING CODE REQUIREMENTS FOR STRUCTURAL CONCRETE.

6. ALL FOUNDATION CONSTRUCTION SHALL BE IN ACCORDANCE WITH THE LATEST EDITIONS OF THE INTERNATIONAL BUILDING CODE (IBC) AND THE ACI 318 BUILDING CODE REQUIREMENTS FOR STRUCTURAL CONCRETE.

7. ALL FOUNDATION CONSTRUCTION SHALL BE IN ACCORDANCE WITH THE LATEST EDITIONS OF THE INTERNATIONAL BUILDING CODE (IBC) AND THE ACI 318 BUILDING CODE REQUIREMENTS FOR STRUCTURAL CONCRETE.

8. ALL FOUNDATION CONSTRUCTION SHALL BE IN ACCORDANCE WITH THE LATEST EDITIONS OF THE INTERNATIONAL BUILDING CODE (IBC) AND THE ACI 318 BUILDING CODE REQUIREMENTS FOR STRUCTURAL CONCRETE.

9. ALL FOUNDATION CONSTRUCTION SHALL BE IN ACCORDANCE WITH THE LATEST EDITIONS OF THE INTERNATIONAL BUILDING CODE (IBC) AND THE ACI 318 BUILDING CODE REQUIREMENTS FOR STRUCTURAL CONCRETE.

10. ALL FOUNDATION CONSTRUCTION SHALL BE IN ACCORDANCE WITH THE LATEST EDITIONS OF THE INTERNATIONAL BUILDING CODE (IBC) AND THE ACI 318 BUILDING CODE REQUIREMENTS FOR STRUCTURAL CONCRETE.

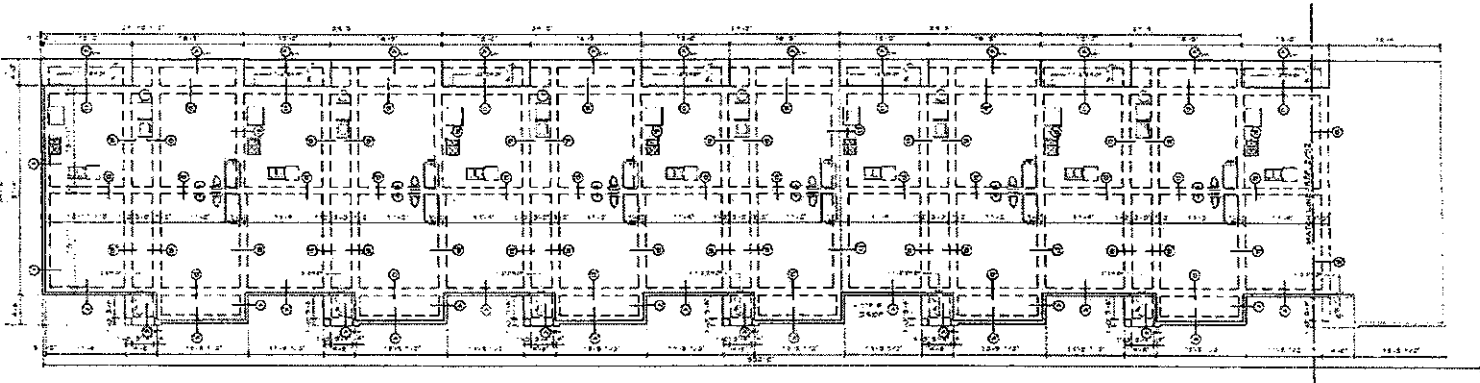
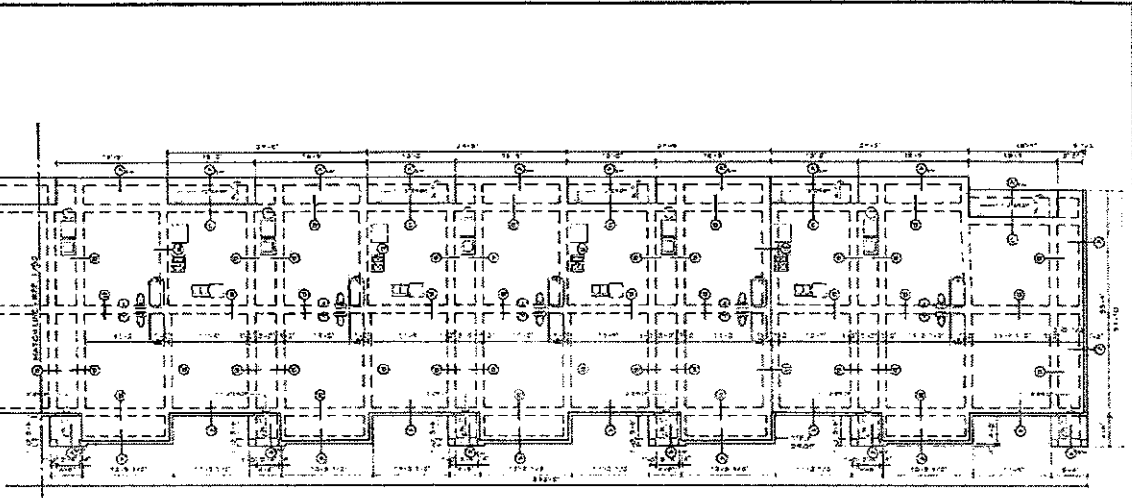

EXHIBIT "A"



COPPER CREEK CONDOS
 COLLEGE STATION TEXAS
Transition Design Service
 201 W. Vike Maria Road - Bryan, Texas 77801 - (979) 822-7777

DATE: 09/27/14
S2

Doc No: 012429014
 Rk No: 13045
 Pg No: 209

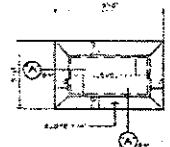

3 FOUND. PLAN MAILBOX
 1/4" = 1'-0"

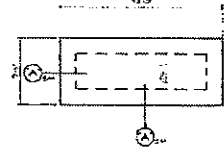

2 FOUND. PLAN BUS STOP
 1/4" = 1'-0"

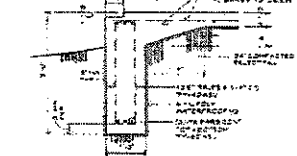
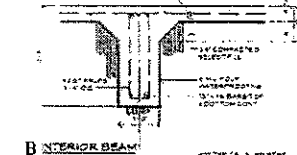
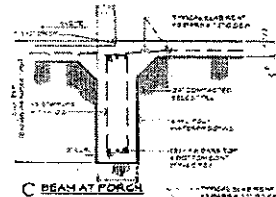
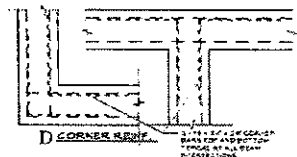

4 FOUNDATION DETAILS
 NOTE: GRADES SHOWN
 ARE TO BE USED FOR
 ALL FOUNDATION WORK
 UNLESS OTHERWISE NOTED
 3/4" = 1'-0"

FOUNDATION SPECIFICATIONS

1. ALL FOUNDATION WORK SHALL BE IN ACCORDANCE WITH THE LATEST EDITIONS OF THE INTERNATIONAL BUILDING CODE (IBC) AND THE ACI 318 BUILDING CODE FOR STRUCTURAL CONCRETE AND COMMENTARIES THEREON.

2. ALL FOUNDATION WORK SHALL BE DESIGNED AND CONSTRUCTED TO RESIST ALL APPLIED LOADS AND MOMENTS.

3. ALL FOUNDATION WORK SHALL BE CONSTRUCTED TO PROVIDE ADEQUATE DRAINAGE AND PROTECTION AGAINST FLOODING.

4. ALL FOUNDATION WORK SHALL BE CONSTRUCTED TO PROVIDE ADEQUATE PROTECTION AGAINST CORROSION.

5. ALL FOUNDATION WORK SHALL BE CONSTRUCTED TO PROVIDE ADEQUATE PROTECTION AGAINST SETTLEMENT.

6. ALL FOUNDATION WORK SHALL BE CONSTRUCTED TO PROVIDE ADEQUATE PROTECTION AGAINST CRACKING.

7. ALL FOUNDATION WORK SHALL BE CONSTRUCTED TO PROVIDE ADEQUATE PROTECTION AGAINST REINFORCING BAR CORROSION.

8. ALL FOUNDATION WORK SHALL BE CONSTRUCTED TO PROVIDE ADEQUATE PROTECTION AGAINST CONCRETE DEGRADATION.

9. ALL FOUNDATION WORK SHALL BE CONSTRUCTED TO PROVIDE ADEQUATE PROTECTION AGAINST WEAR AND TEAR.

10. ALL FOUNDATION WORK SHALL BE CONSTRUCTED TO PROVIDE ADEQUATE PROTECTION AGAINST COLLAPSE.

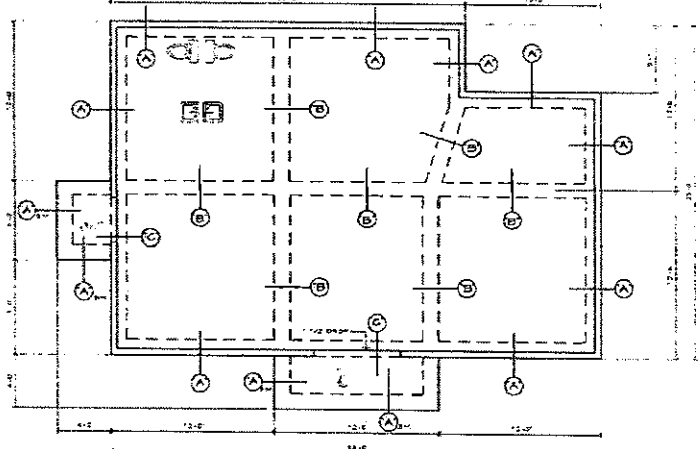

1 FOUNDATION PLAN CLUB HOUSE PHASE 1
 1/4" = 1'-0"



COPPER CREEK CONDOS
 COLLEGE STATION TEXAS
Transition Design Service
 301 W. Villa Maria Road • Bryan, Texas 77801 • (979) 822-7777

DATE: 08/11/2014
SS

LEGEND OF SYMBOLS:

SYMBOLS LEGEND		LINE LEGEND	
	Manhole		Property Line
	Fire Hydrant		Tract/Lot Line
	Sign		Building Setback Line
	Clean-Out		Easement Line
	Light Pole		Overhead Electric Line
	Power Pole		Piping Line
	Gate Valve		Fence
	Water Meter		Edge of Pavement/Gravel
	Transformer Box		
	Gate		

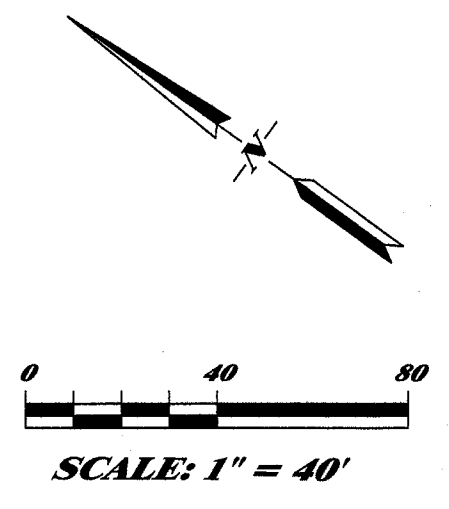

VICINITY MAP
(NOT TO SCALE)

Field Notes
Tract Two
6.33 Acres

Being all of that certain tract or parcel of land, lying and being situated in the CRAWFORD BURNETT LEAGUE, Abstract No. 7, College Station, Brazos County, Texas, and being all of lot 2R of William Brooke Hunter Estates according to the plat recorded in Volume 7627, page 19, of the Official Records of Brazos County, Texas and being more particularly described as follows:

BEGINNING: at a 5/8" iron rod with cap set found at the most southerly common corner of this tract and lot 1R of said Subdivision and being in the northwesterly Right-of-Way line of Southwest Parkway; same being the beginning of a curve to the left;

THENCE: 39.27 feet around said curve to the left with a radius of 25.00 feet and whose chord bears N 09° 20' 35" E - 35.36 feet along the common line between this tract and said lot 1R to a 1/2" iron rod with cap (4502) found at the end of said curve;

THENCE: continuing along said common line between this tract and said lot 1R for the following calls:

S 35° 39' 25" E - 189.00 feet,
S 54° 20' 35" W - 29.87 feet and

S 35° 39' 25" E - 423.01 feet to a 5/8" iron rod with cap (4502) found for the most westerly common corner of this tract and lot 9, block 2 of the South-Land Addition recorded in (134/423);

N 42° 33' 47" E - 551.20 feet along the common line between this tract and lots 9 through 20, block 2 of said South-Land Addition to a point for the most northerly common corner of this tract, lot 20 of said South-Land Addition and lot 1 of Parkway Circle recorded in (508/561);

THENCE: along the common line between this tract and said lot 1 of Parkway Circle for the following calls:

S 54° 20' 35" W - 29.87 feet,
S 66° 37' 17" E - 36.34 feet,
N 09° 57' 46" W - 38.37 feet,
S 30° 10' 06" E - 33.63 feet,
S 09° 46' 36" E - 65.99 feet,
N 25° 50' 07" E - 31.91 feet,
N 01° 22' 52" E - 30.28 feet,
N 71° 17' 14" E - 28.00 feet,
S 20° 57' 19" E - 50.21 feet,
S 71° 42' 07" E - 46.32 feet,
S 29° 33' 57" E - 26.07 feet,
N 17° 24' 05" E - 79.27 feet,
N 02° 53' 48" E - 81.73 feet,
N 24° 17' 05" E - 61.14 feet and

THENCE: S 17° 27' 19" E - 145.73 feet to a point for the most southeasterly common corner of this tract and said lot 1 of Parkway Circle; same being in said Right-of-Way line of Southwest Parkway;

THENCE: S 54° 20' 35" W - 229.90 feet along said Right-of-Way line of Southwest Parkway to the PLACE OF BEGINNING; and containing 6.33 acres of land, more or less, according to a survey made on the ground under the supervision of Donald Garrett, Registered Professional Land Surveyor, No. 2972 on July 24, 2015.

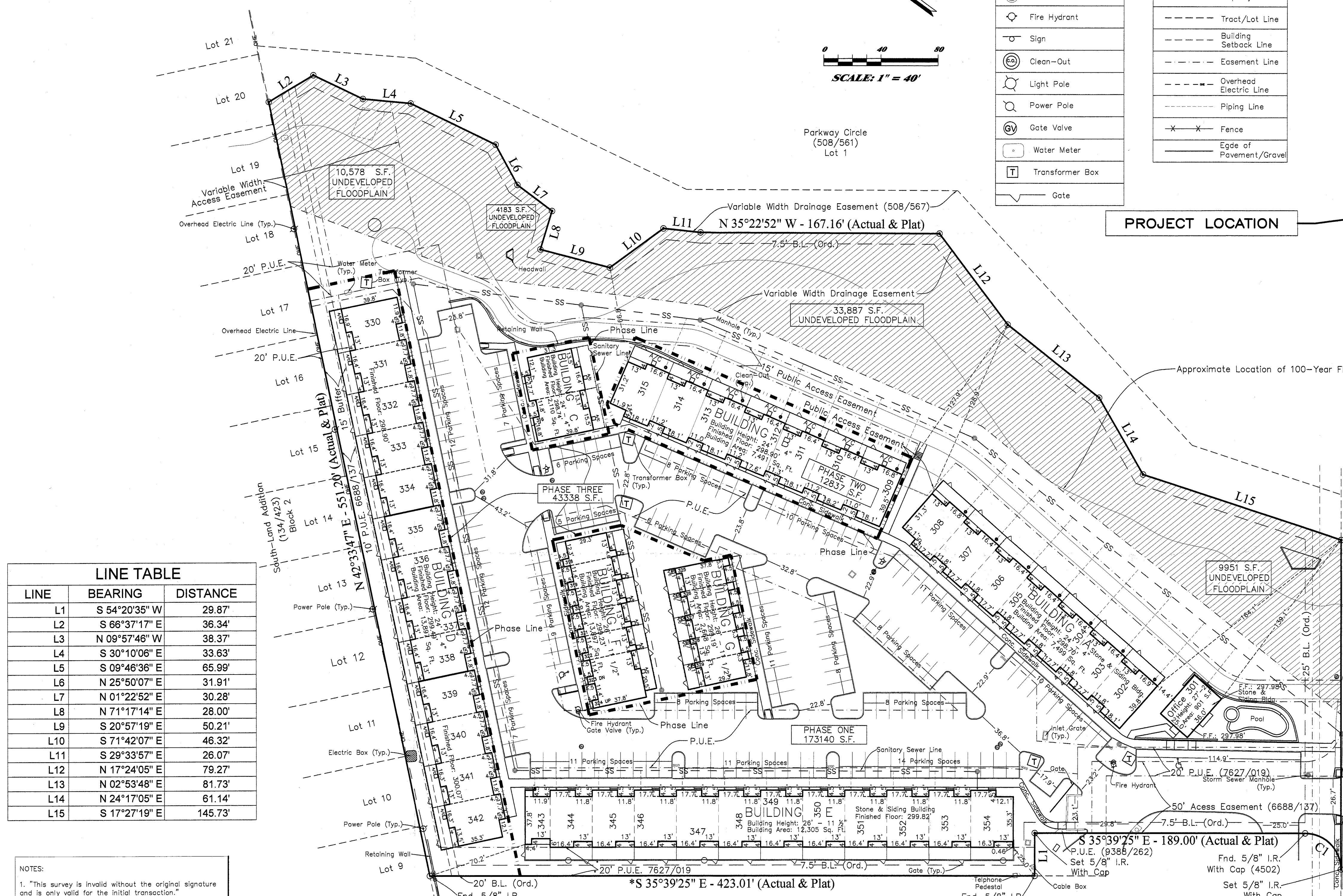

LINE TABLE

LINE	BEARING	DISTANCE
L1	S 54°20'35" W	29.87'
L2	S 66°37'17" E	36.34'
L3	N 09°57'46" W	38.37'
L4	S 30°10'06" E	33.63'
L5	S 09°46'36" E	65.99'
L6	N 25°50'07" E	31.91'
L7	N 01°22'52" E	30.28'
L8	N 71°17'14" E	28.00'
L9	S 20°57'19" E	50.21'
L10	S 71°42'07" E	46.32'
L11	S 29°33'57" E	26.07'
L12	N 17°24'05" E	79.27'
L13	N 02°53'48" E	81.73'
L14	N 24°17'05" E	61.14'
L15	S 17°27'19" E	145.73'

NOTES:

- "This survey is invalid without the original signature and is only valid for the initial transaction."
- *Basis-of-Bearing: Plat bearing used as Basis of Bearing.
- Fence lines may not be exactly on property lines.
- This Survey was prepared using without the benefit of a Title Company's Title Commitment.
- Utility Note: The underground utilities shown have been located from field survey information and existing drawings. The surveyor makes no guarantee that the underground utilities shown comprise all such utilities in the area, either in service or abandoned. The surveyor further does not warrant that the underground utilities shown are in the exact location indicated although he does certify that they are located as accurately as possible from information available. The surveyor has not physically located the underground utilities.
- This Property is Zoned: PDD Planned Development District.
- A Portion of this property is in the 100-year flood hazard area as established by the Federal Emergency Management Agency, FEMA Firm Community Panel No. 48041C0305F, April 2, 2014.
- Parking: Standard Parking Spaces Required: 193 Standard Parking Spaces Provided: 195 Van Accessible Handicap Parking Spaces Provided: 2
- No monuments were set in creek.

CURVE TABLE

CURVE	RADIUS	DELTA	TANGENT	LENGTH	CHD.	L.C.
C1	25.00'	90°00'00"	25.00'	39.27'	N 09°20'35" E	35.36'

Being Lot 2R of WILLIAM BROOKE HUNTER ESTATES, lying and being situated in the Crawford Burnett League, A-7, in Brazos County, Texas.

The undersigned further hereby certifies to said parties as of the 24th day of July, 2015, that the survey conforms to the "2011 Minimum Standard Detail Requirements for ALTA/ACSM Land Title Surveys," jointly established and adopted by ALTA and NSPS, and includes items 1-5, 7(a), 7(c), 8, 9, 10(a), 10(b), 11(b), 13-19, 20(a) of Table A thereof. The field work was completed on August 10, 2015.

I, Donald Garrett, GARRETT ENGINEERING CONSULTING ENGINEERING & LAND SURVEYING, a registered land surveyor, do hereby certify to the CITY OF COLLEGE STATION, Brazos County, Texas, that this instrument is a true and correct survey made on the ground under my supervision.

I further certify that no improvements on this property encroach on adjacent property nor do any improvements on adjacent property encroach on this property, except as shown.

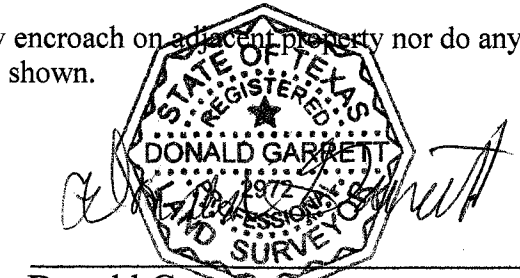

Donald Garrett
Registered Professional Land Surveyor No. 2972

ALTA/ACSM LAND TITLE SURVEY
OF
LOT 2R (6.33 Acres)
(Amended to add Buildings "C", "D", "F" & "G" - Phase Three)
WILLIAM BROOKE HUNTER ESTATES
CRAWFORD BURNETT LEAGUE, ABSTRACT NO. 7
301 SOUTHWEST PARKWAY
COLLEGE STATION, BRAZOS COUNTY TEXAS

GARRETT ENGINEERING
Consulting Engineering & Land Surveying
4444 Carter Creek Parkway Suite 108
Bryan, Texas 77802
Telephone : (979) 846 - 2888
Fax : (979) 846 - 3094

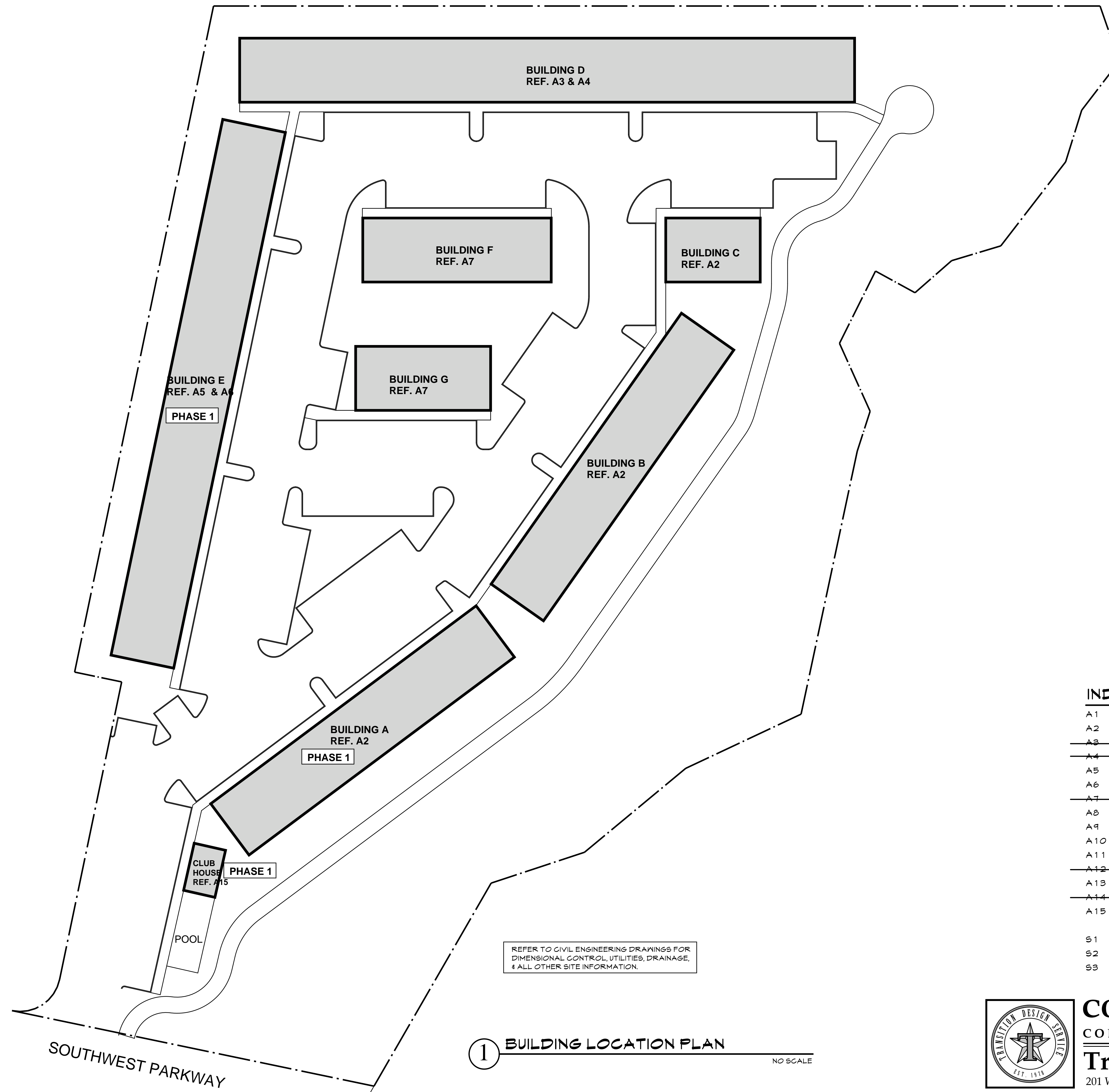

INDEX OF DRAWINGS

A1	BUILDING LOCATION PLAN
A2	BUILDING A, B & C - 1st & 2nd FLOOR PLANS
A3	BUILDING D - 1st FLOOR PLAN
A4	BUILDING D - 2nd FLOOR PLAN
A5	BUILDING E - 1st FLOOR PLAN
A6	BUILDING E - 2nd FLOOR PLAN
A7	BUILDING F & G - 1st & 2nd FLOOR PLANS
A8	UNIT PLANS - 4 BEDROOM, 4 BATH
A9	UNIT PLANS - 2 BEDROOM, 2 BATH
A10	WALL SECTION, DETAILS & NOTES
A11	BUILDING A, B & C - ELEVATIONS
A12	BUILDING D - ELEVATIONS
A13	BUILDING E - ELEVATIONS
A14	BUILDING F & G - ELEVATIONS
A15	CLUB HOUSE, BUS STOP & MAILBOX PLANS
S1	FOUNDATION PLAN & DETAILS, BUILDING A
S2	FOUNDATION PLAN & DETAILS, BUILDING E
S3	FOUNDATION PLAN & DETAILS, MISC. BLDGS.

SHEETS NOT RELEVANT TO PHASE 1 HAVE BEEN OMITTED

1 BUILDING LOCATION PLAN
 NO SCALE

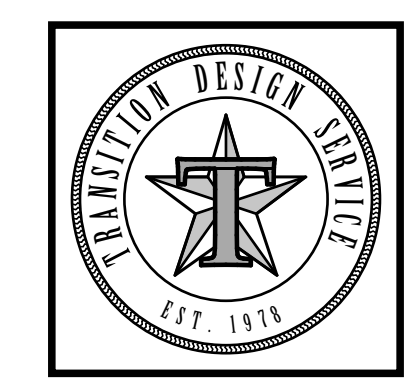

COPPER CREEK CONDOS
 COLLEGE STATION TEXAS
Transition Design Service
 201 W. Villa Maria Road * Bryan, Texas 77801 * (979) 822-7777

DATE: SEPT. 2014
A 1

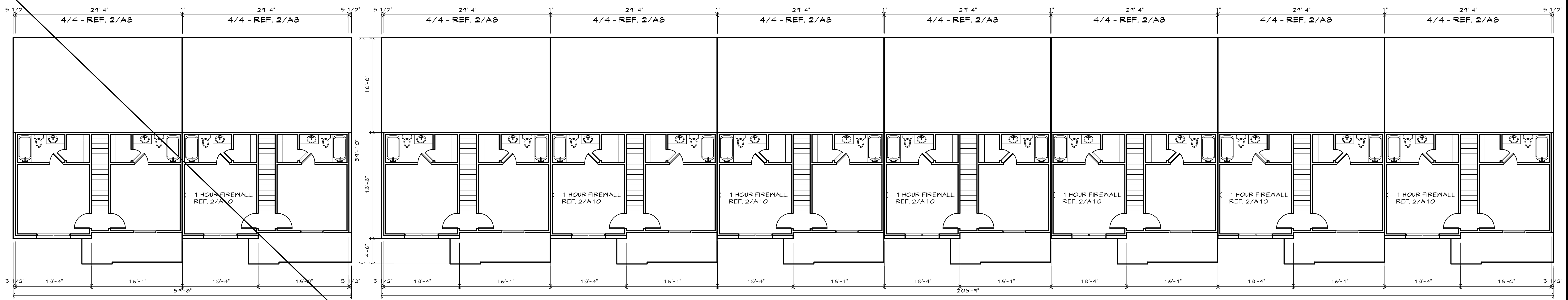

④ BLDG. C - 2nd FLOOR PLAN
 1/8" = 1'-0" PHASE 3

② BLDG. A & B - 2nd FLOOR PLAN
 1/8" = 1'-0" BLDG. A - PHASE 1

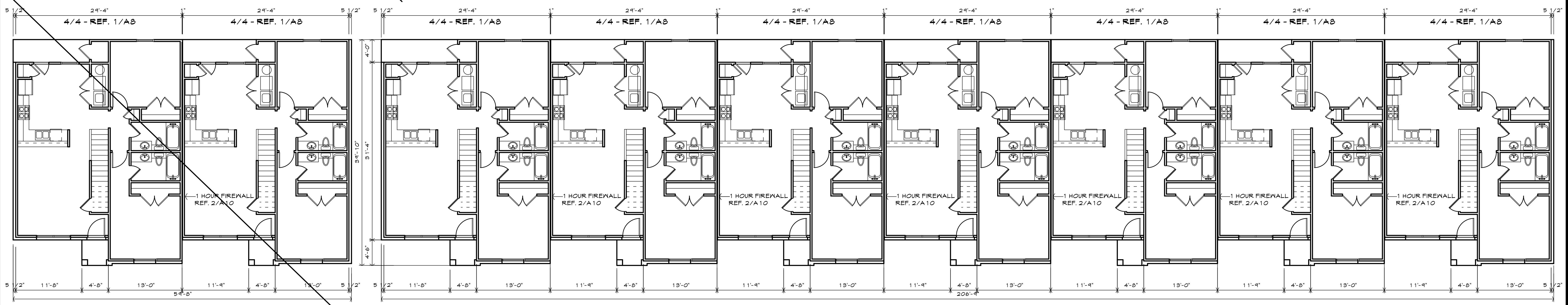

③ BLDG. C - 1st FLOOR PLAN
 1/8" = 1'-0" PHASE 3

① BLDG. A & B - 1st FLOOR PLAN
 1/8" = 1'-0" BLDG. A - PHASE 1

SLAB AREA: 2261 sf.
 HEATED AREA: 3078 sf. ←

HEATED AREA INDICATED IS CALCULATED TO OUTSIDE FACE OF STUDS & DOES NOT INCLUDE BRICK VENEER, PORCHES OR BALCONIES

7,098,7904 sq ft
 3,687 sq ft

SLAB AREA: 7836 sf.
 HEATED AREA: 10,786 sf. ←

HEATED AREA INDICATED IS CALCULATED TO OUTSIDE FACE OF STUDS & DOES NOT INCLUDE BRICK VENEER, PORCHES OR BALCONIES

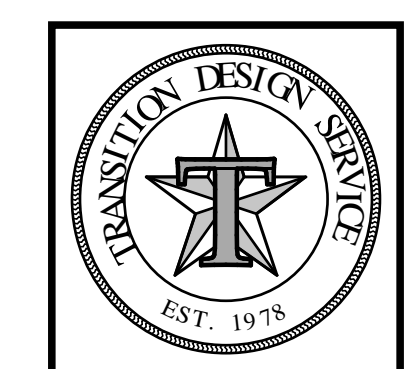

COPPER CREEK CONDOS
 COLLEGE STATION TEXAS
Transition Design Service
 201 W. Villa Maria Road * Bryan, Texas 77801 * (979) 822-7777

DATE: SEPT. 2014
A2

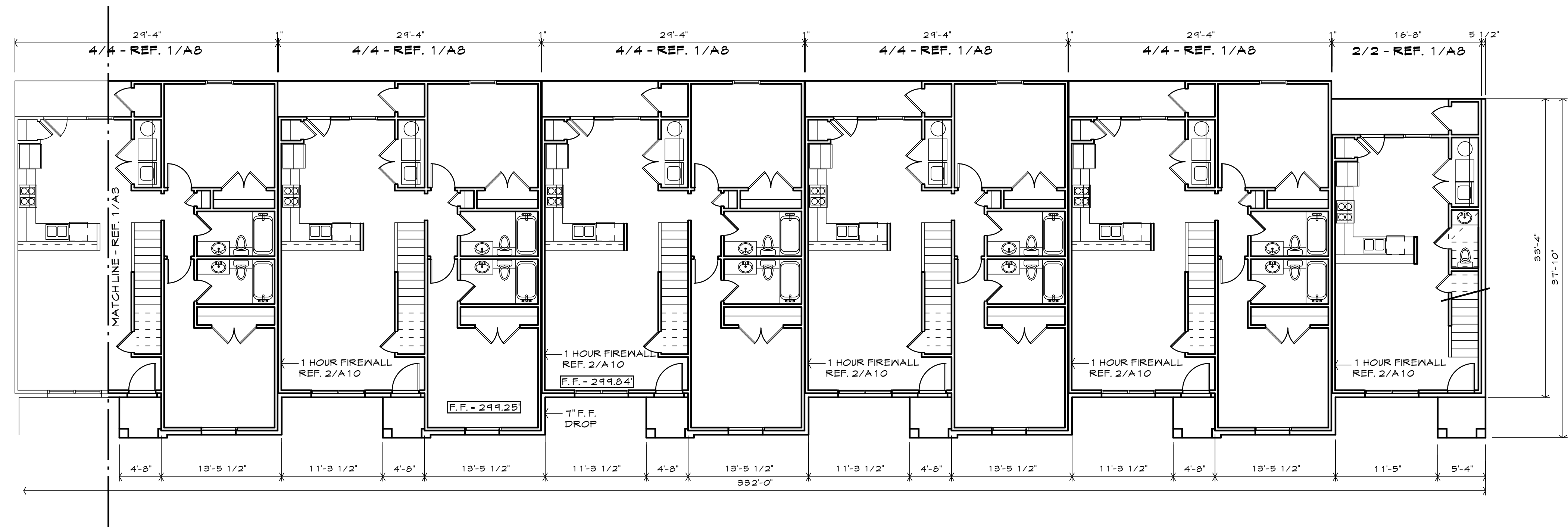

② BLDG. E - 1st FLOOR PLAN (RIGHT) PHASE 1
 1/8" = 1'-0"

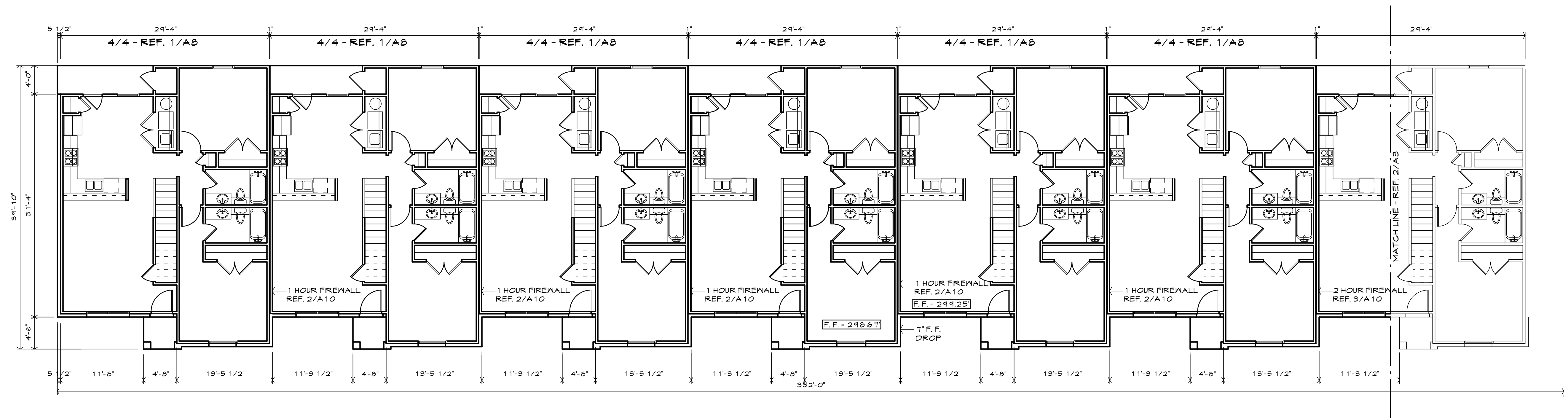

① BLDG. E - 1st FLOOR PLAN (LEFT) PHASE 2
 1/8" = 1'-0"

SLAB AREA: 12,898 s.f.
 HEATED AREA: 20,033 s.f.
 HEATED AREA INDICATED IS CALCULATED TO OUTSIDE FACE OF STUDS & DOES NOT INCLUDE BRICK VENEER, PORCHES OR BALCONIES

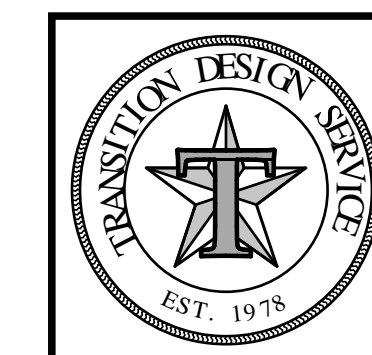

COPPER CREEK CONDOS
 COLLEGE STATION TEXAS
Transition Design Service
 201 W. Villa Maria Road * Bryan, Texas 77801 * (979) 822-7777

DATE: SEPT. 2014

A5

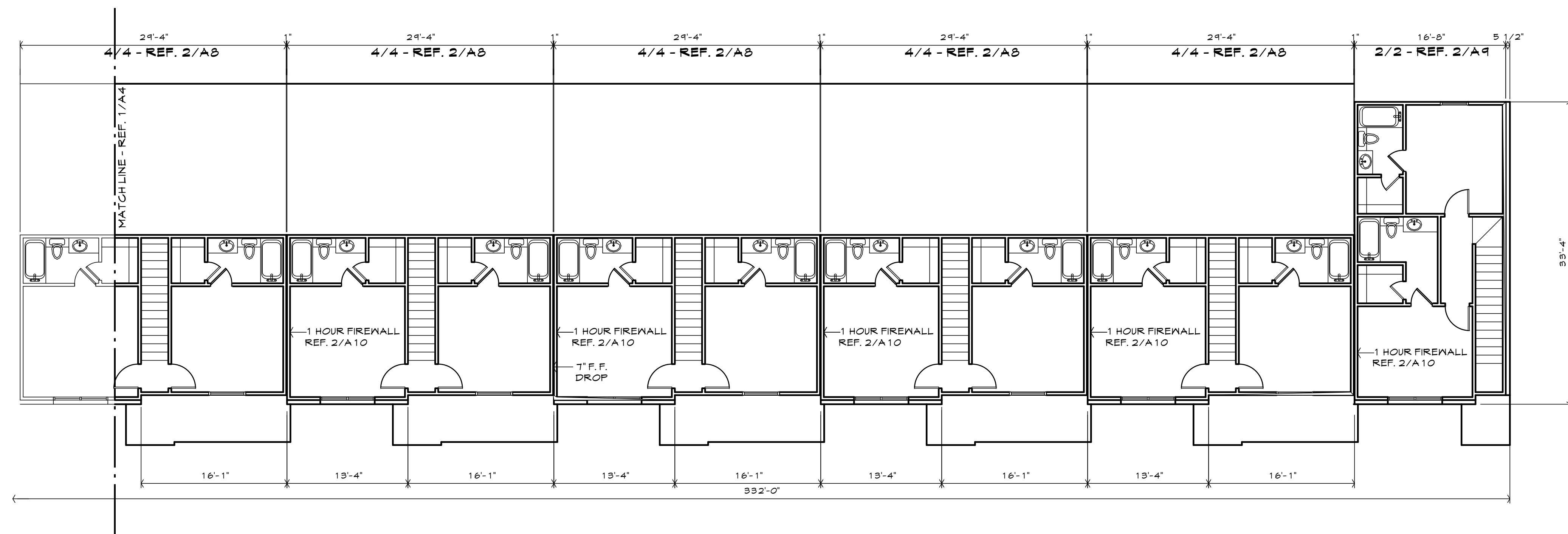

② BLDG. E - 2nd FLOOR PLAN (RIGHT) PHASE 1
1/8" = 1'-0"

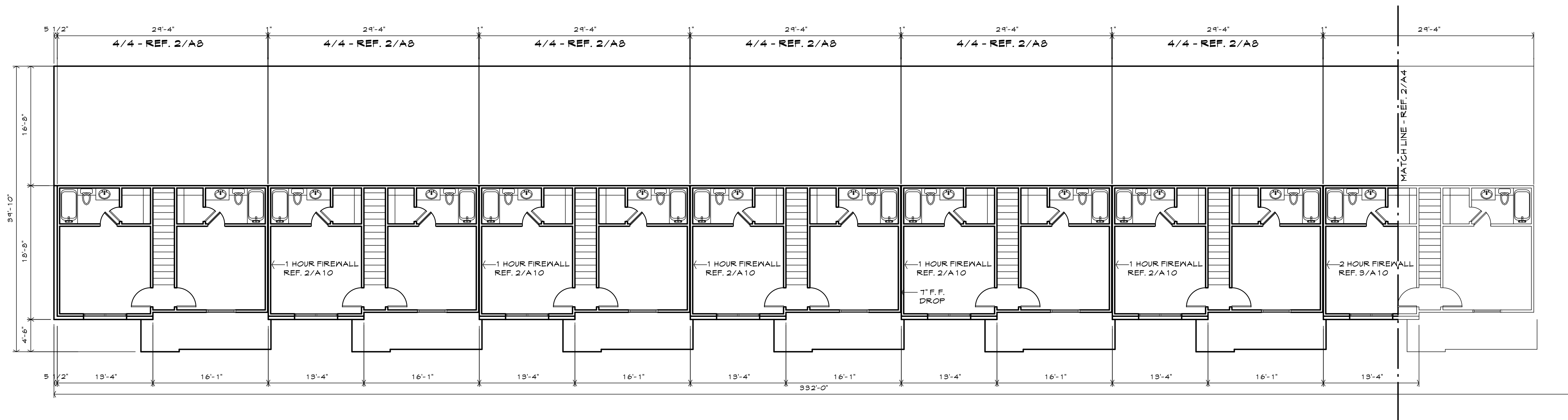

① BLDG. E - 2nd FLOOR PLAN (LEFT) PHASE 1
1/8" = 1'-0"

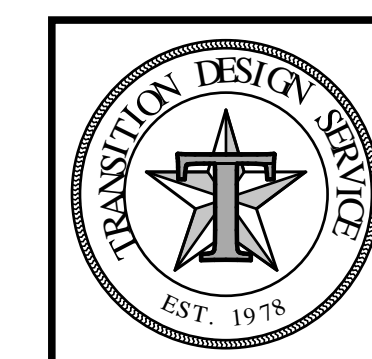

COPPER CREEK CONDOS
COLLEGE STATION TEXAS
Transition Design Service
201 W. Villa Maria Road * Bryan, Texas 77801 * (979) 822-7777

DATE: SEPT. 2014

A6

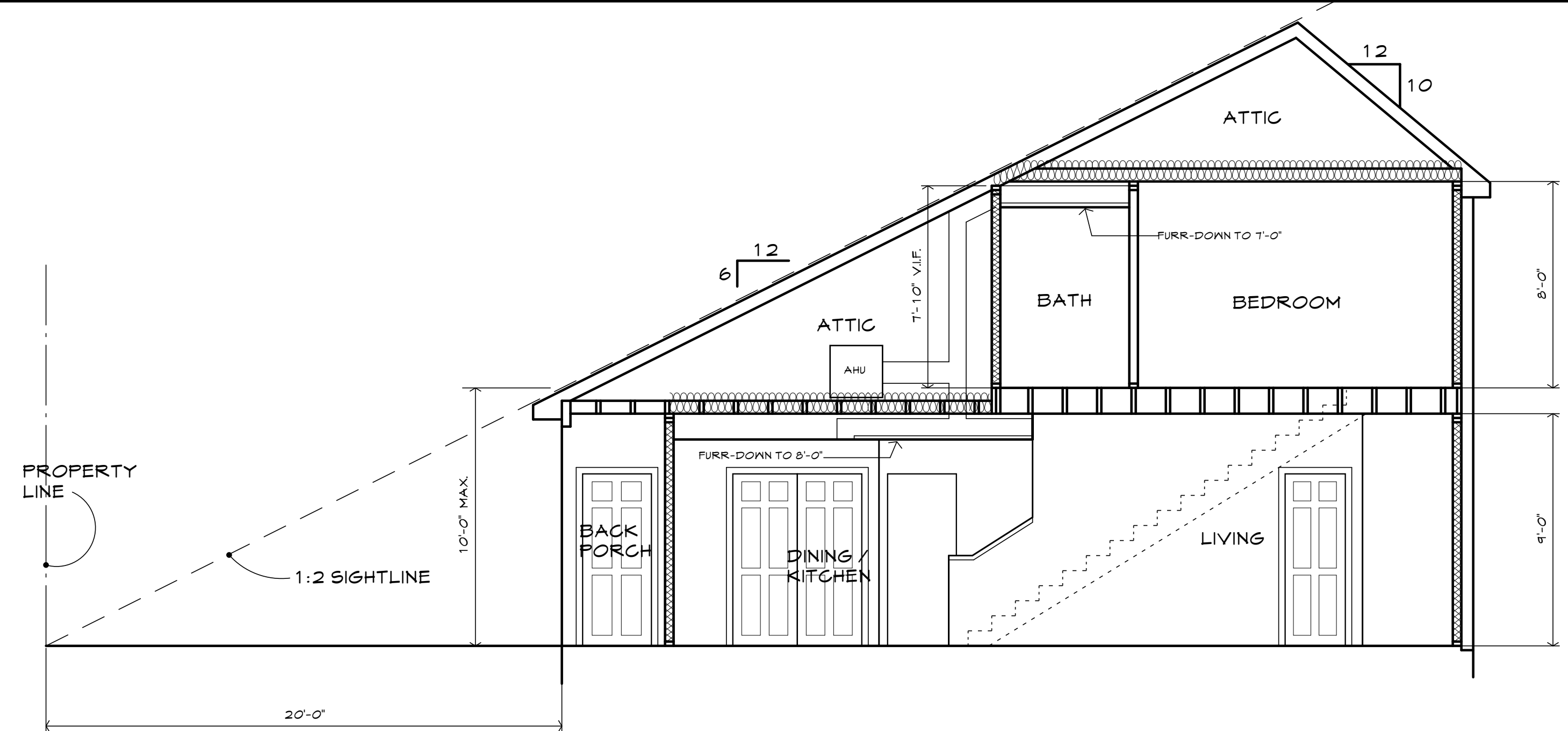

③ 4-4 SECTION
 1/4" = 1'-0"

- DUPLEX OUTLET
- GROUND FAULT ISOLATED OUTLET
- WATERPROOF DUPLEX OUTLET
- SPECIAL PURPOSE OUTLET
- TELEPHONE JACK
- CABLE OUTLET
- SWITCH
- 3-WAY SWITCH
- SURFACE MOUNTED LIGHT
- PENDANT MOUNTED LIGHT
- RECESSED INCANDESCENT
- EXHAUST FAN
- DOOR BELL
- DOOR BELL CHIMES
- SMOKE DETECTOR
- CEILING FAN W/ LIGHT KIT

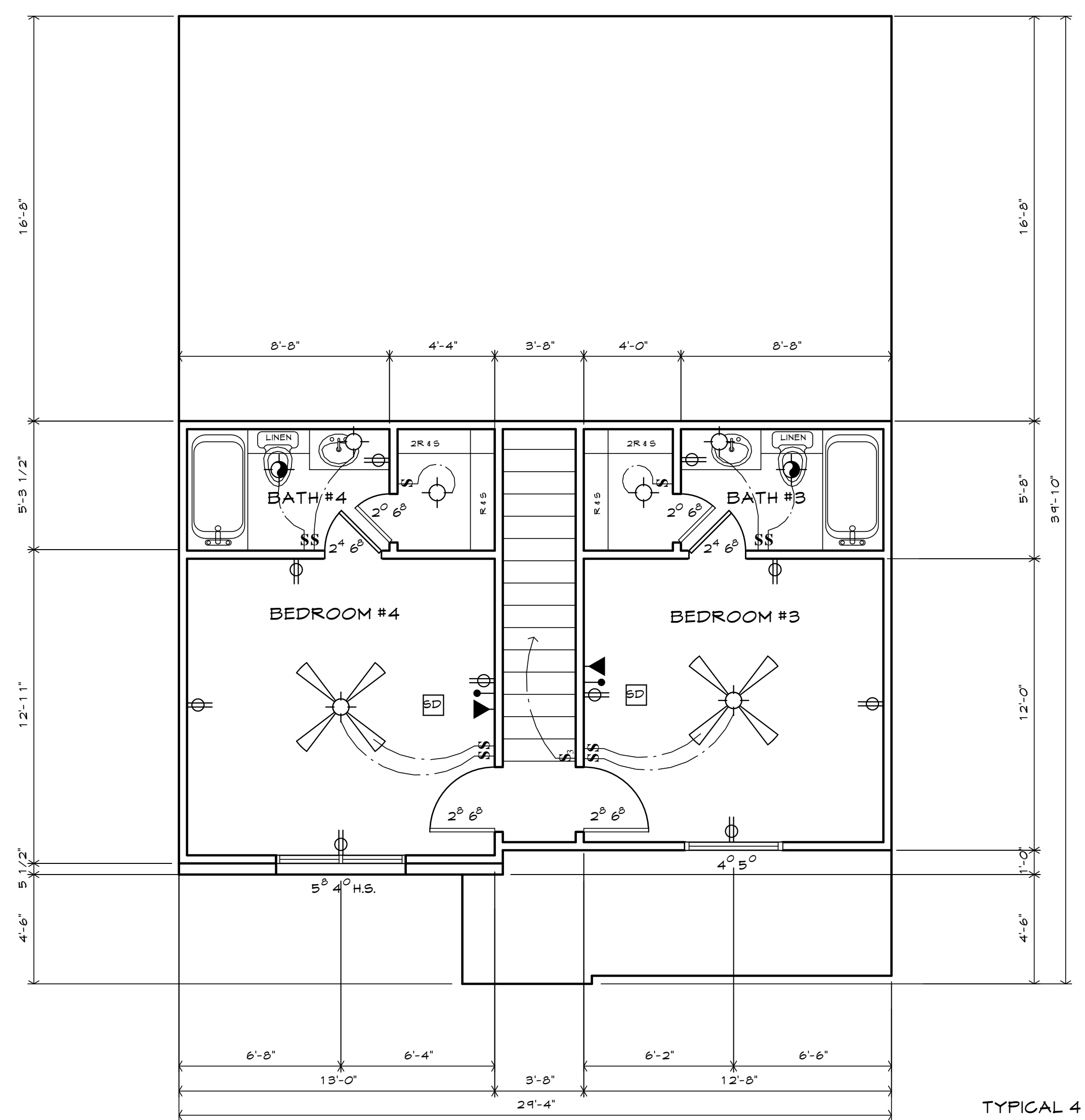

② 2nd FLOOR PLAN 4-4 (532 s.f.)
 1/4" = 1'-0"

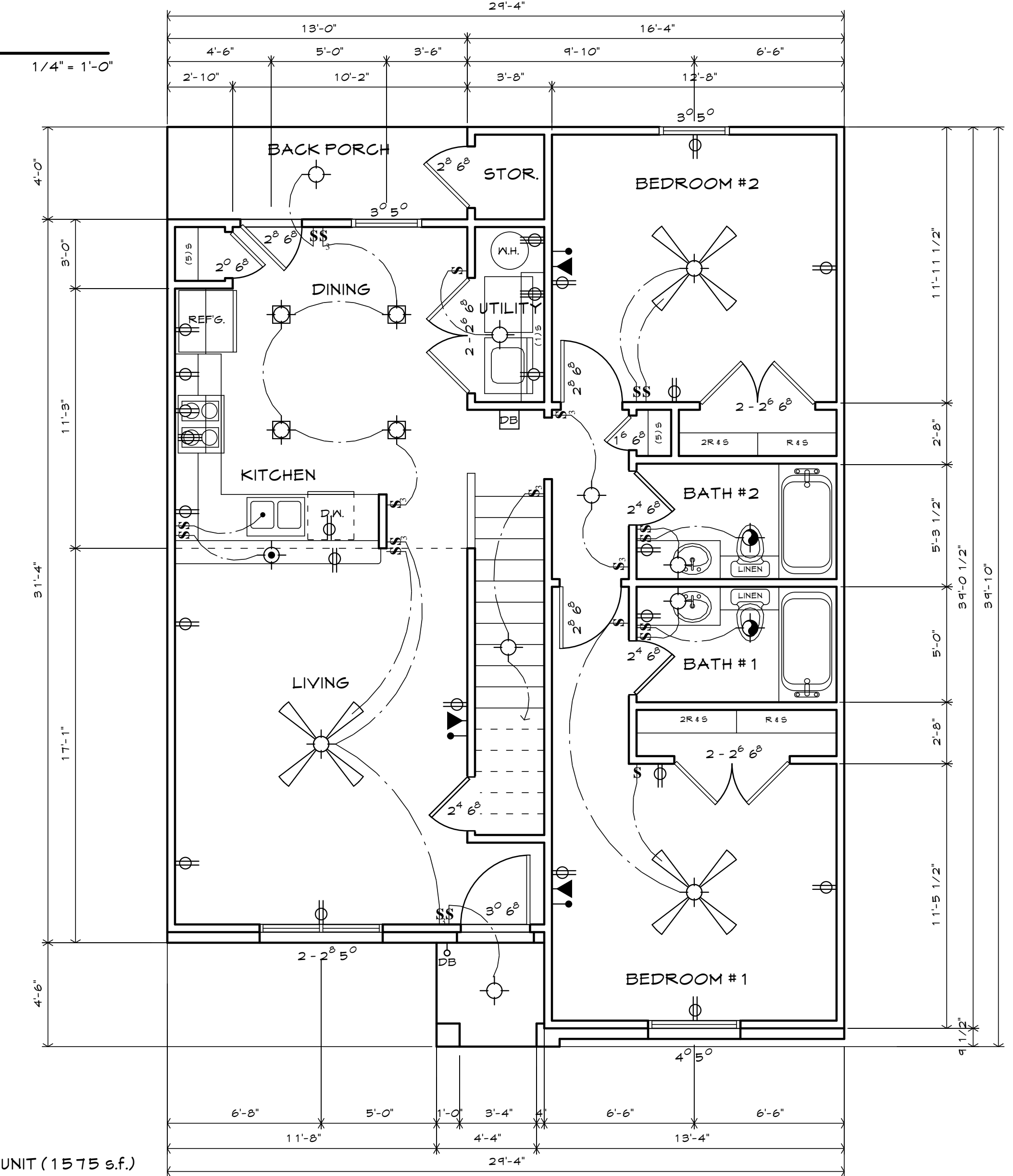



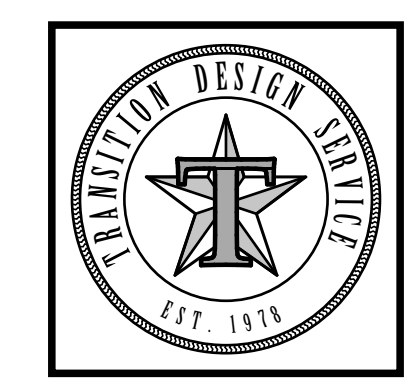













① 1st FLOOR PLAN 4-4 (1043 s.f.)
 1/4" = 1'-0"



COPPER CREEK CONDOS
 COLLEGE STATION TEXAS
Transition Design Service
 201 W. Villa Maria Road * Bryan, Texas 77801 * (979) 822-7777

DATE: SEPT. 2014
A8

-  DUPLEX OUTLET
-  GROUND FAULT ISOLATED OUTLET
-  WATERPROOF DUPLEX OUTLET
-  SPECIAL PURPOSE OUTLET
-  TELEPHONE JACK
-  CABLE OUTLET
-  SWITCH
-  3-WAY SWITCH
-  SURFACE MOUNTED LIGHT
-  PENDANT MOUNTED LIGHT
-  RECESSED INCANDESCENT
-  EXHAUST FAN
-  DOOR BELL
-  DOOR BELL CHIMES
-  SMOKE DETECTOR
-  CEILING FAN W/ LIGHT KIT

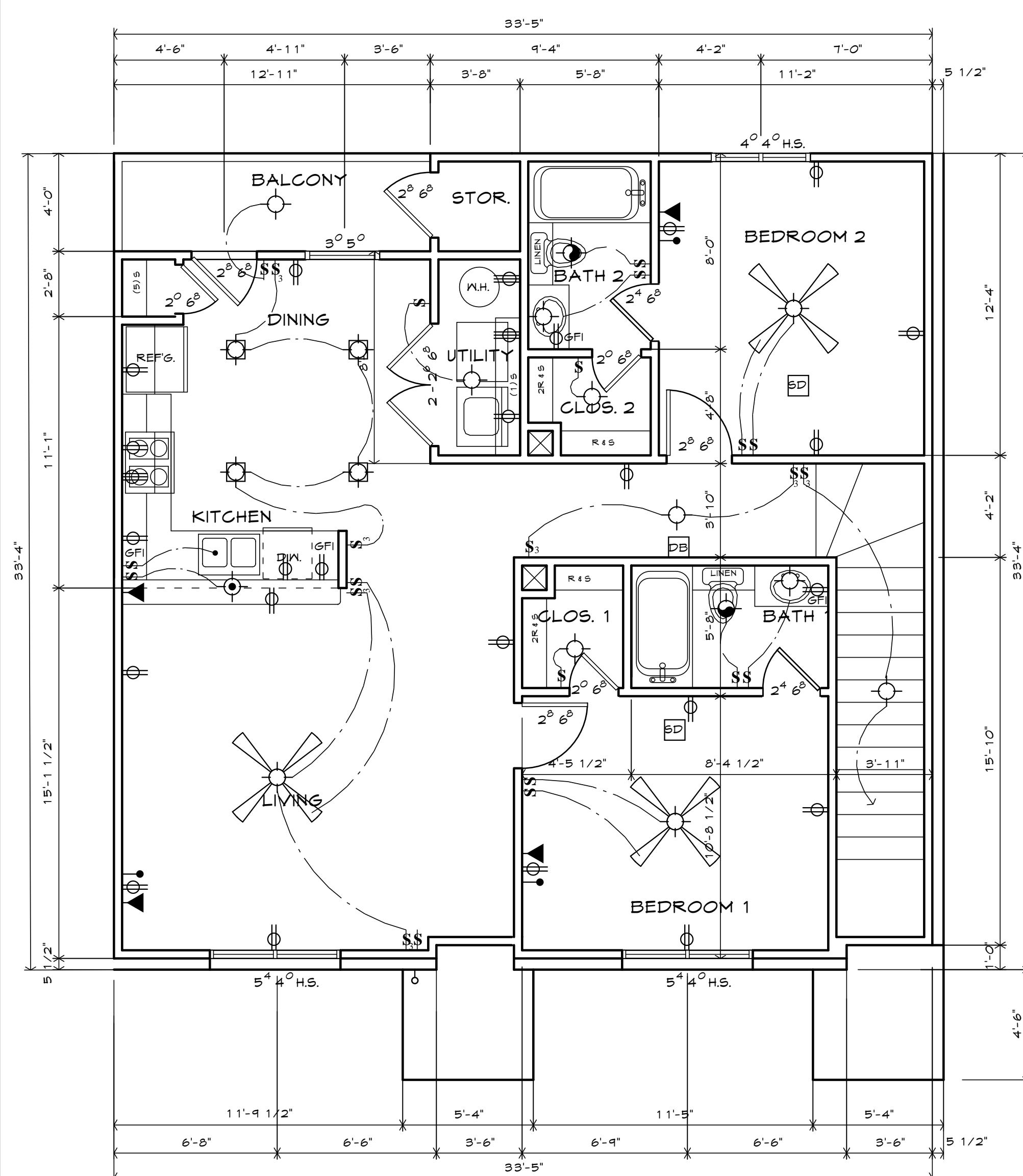

④ 2nd FLOOR PLAN 2-2 "B" Heated Area: 1029 s.f.
 1/4" = 1'-0"

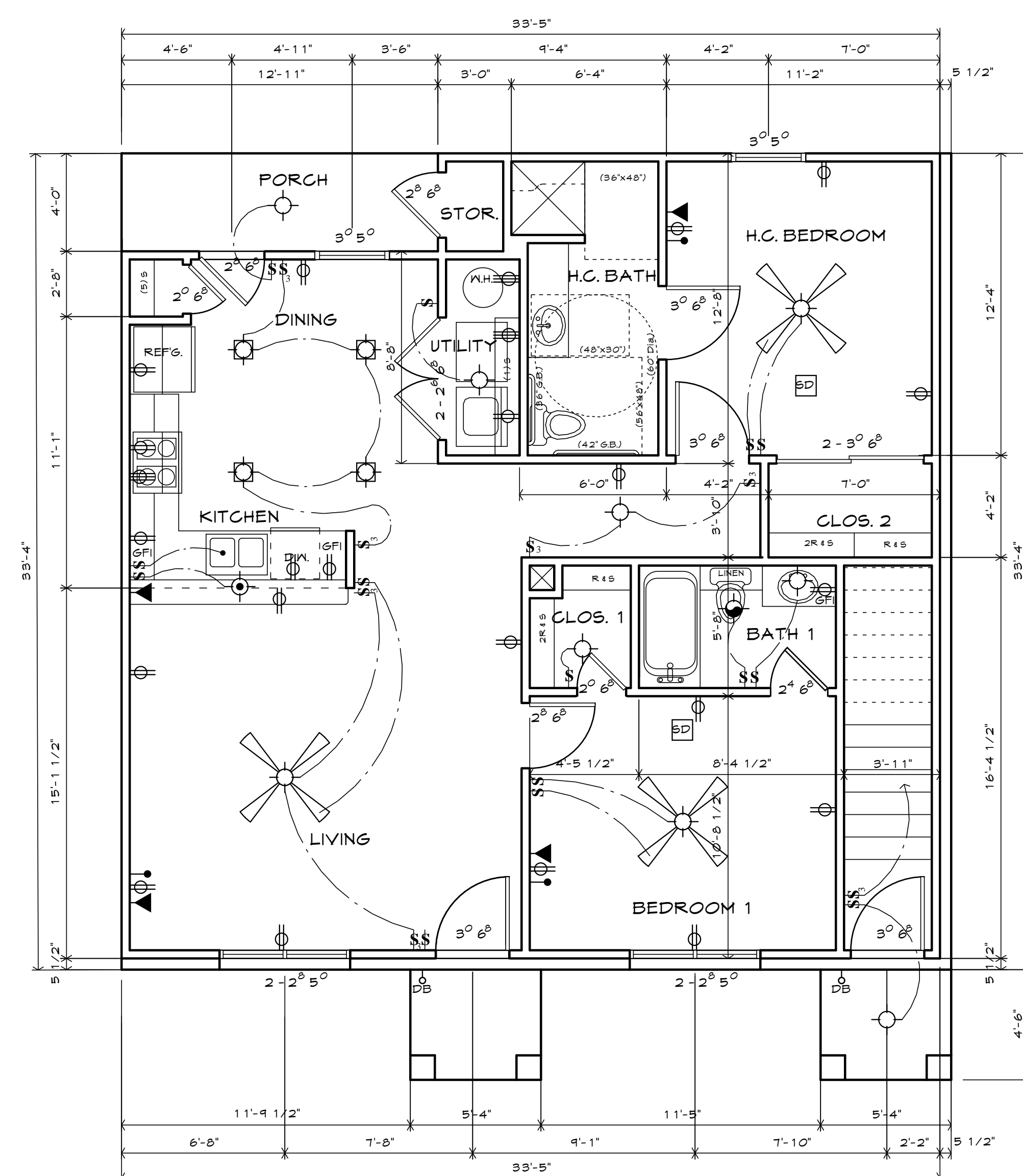

③ 1st FLOOR PLAN 2-2 "HC" Heated Area: 973 s.f.
 1/4" = 1'-0"

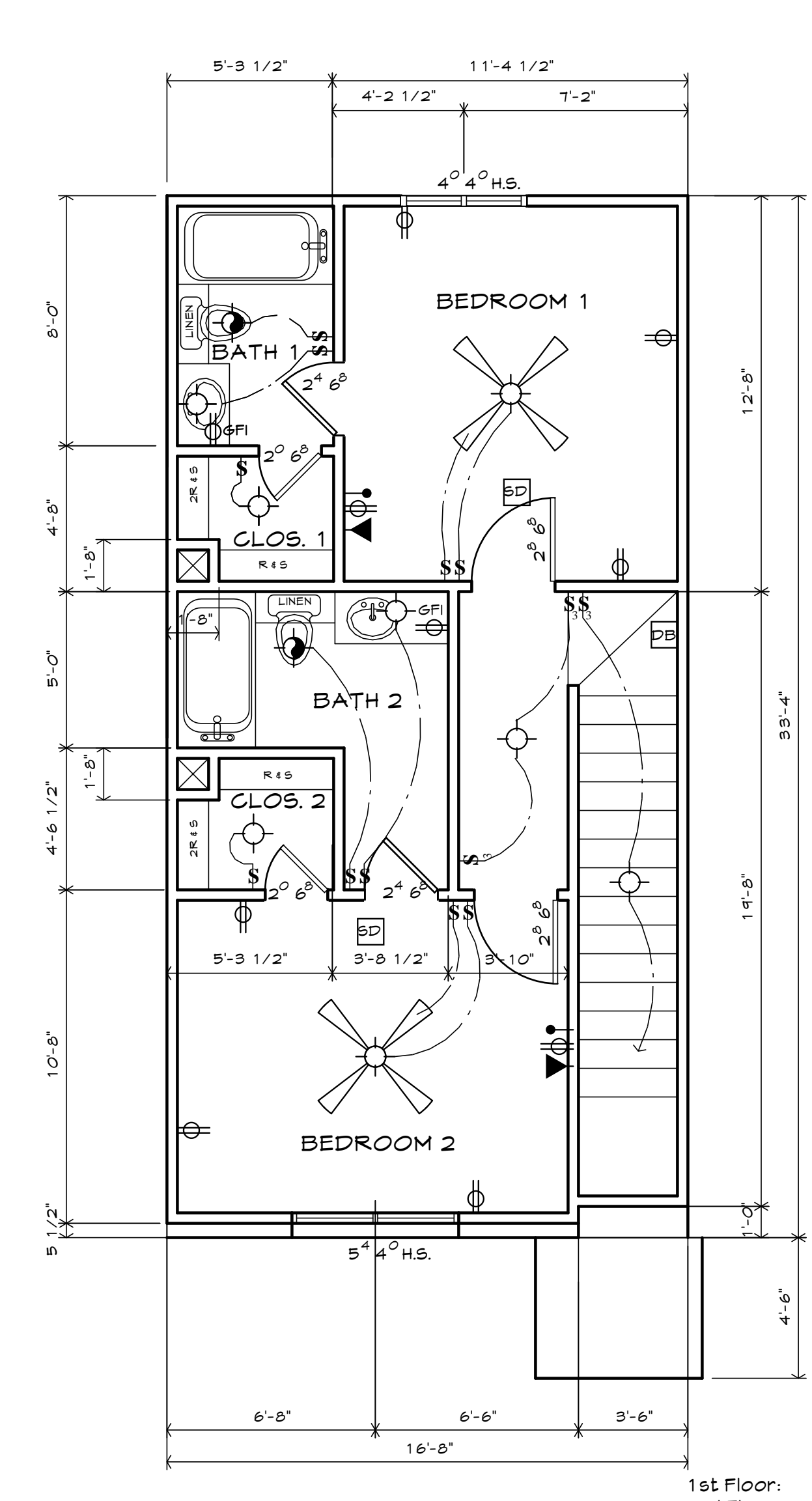

② 2nd FLOOR PLAN 2-2
 1/4" = 1'-0"

1st Floor: 489 s.f.
 2nd Floor: 555 s.f.
 Heated Area: 1044 s.f.

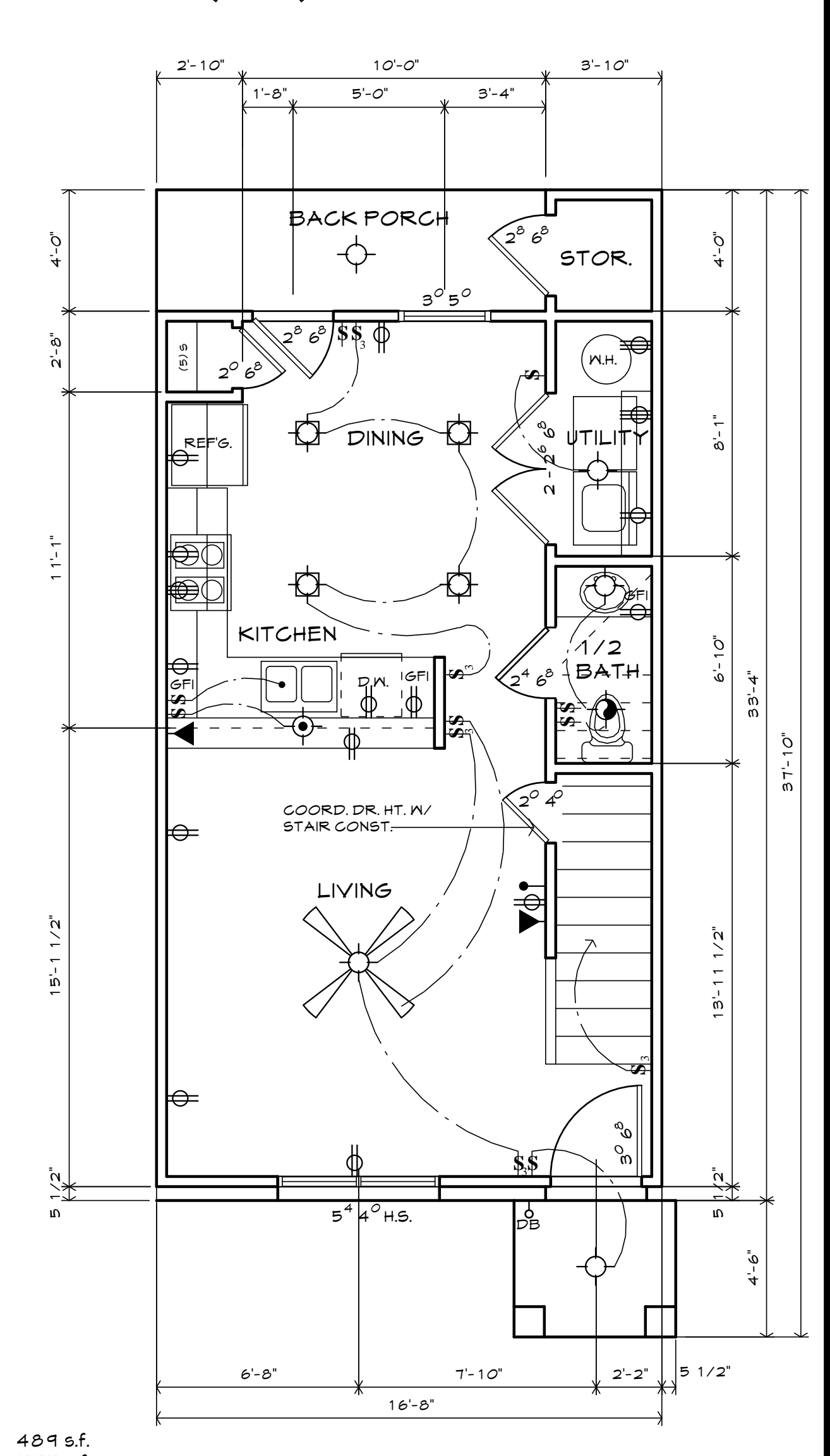

① 1st FLOOR PLAN 2-2
 1/4" = 1'-0"

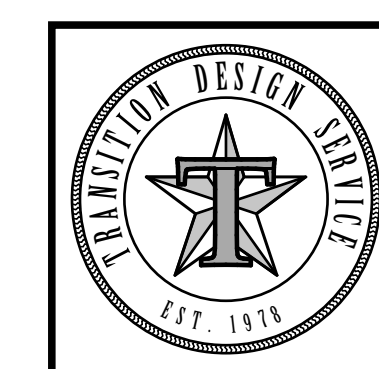

COPPER CREEK CONDOS
 COLLEGE STATION TEXAS
Transition Design Service
 201 W. Villa Maria Road * Bryan, Texas 77801 * (979) 822-7777

DATE: SEPT. 2014
A9

NOTE: RATED WALL CONSTRUCTION TO EXTEND THROUGH ATTIC SPACE TO ROOF DECK ABOVE 3rd FLOOR.

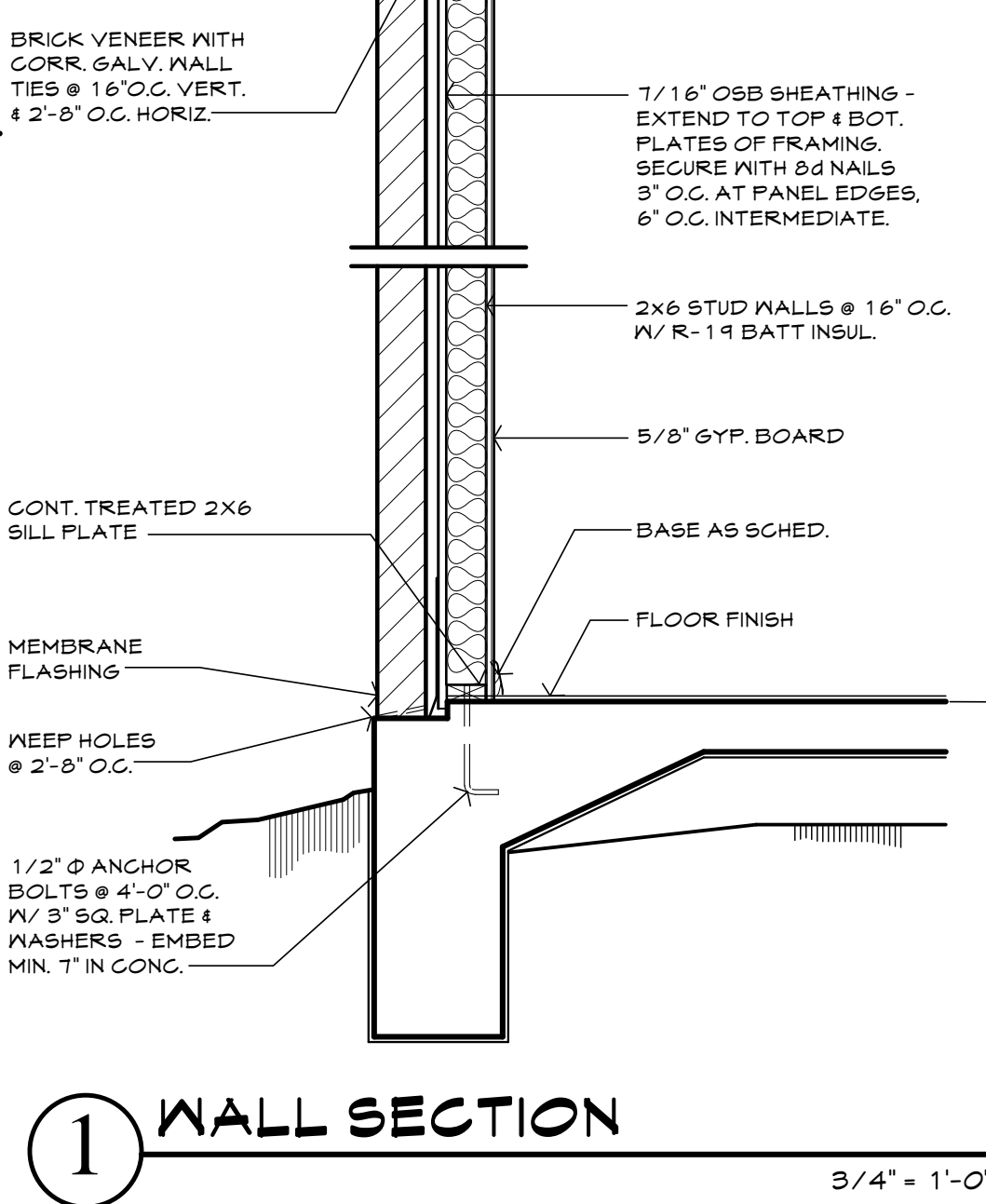
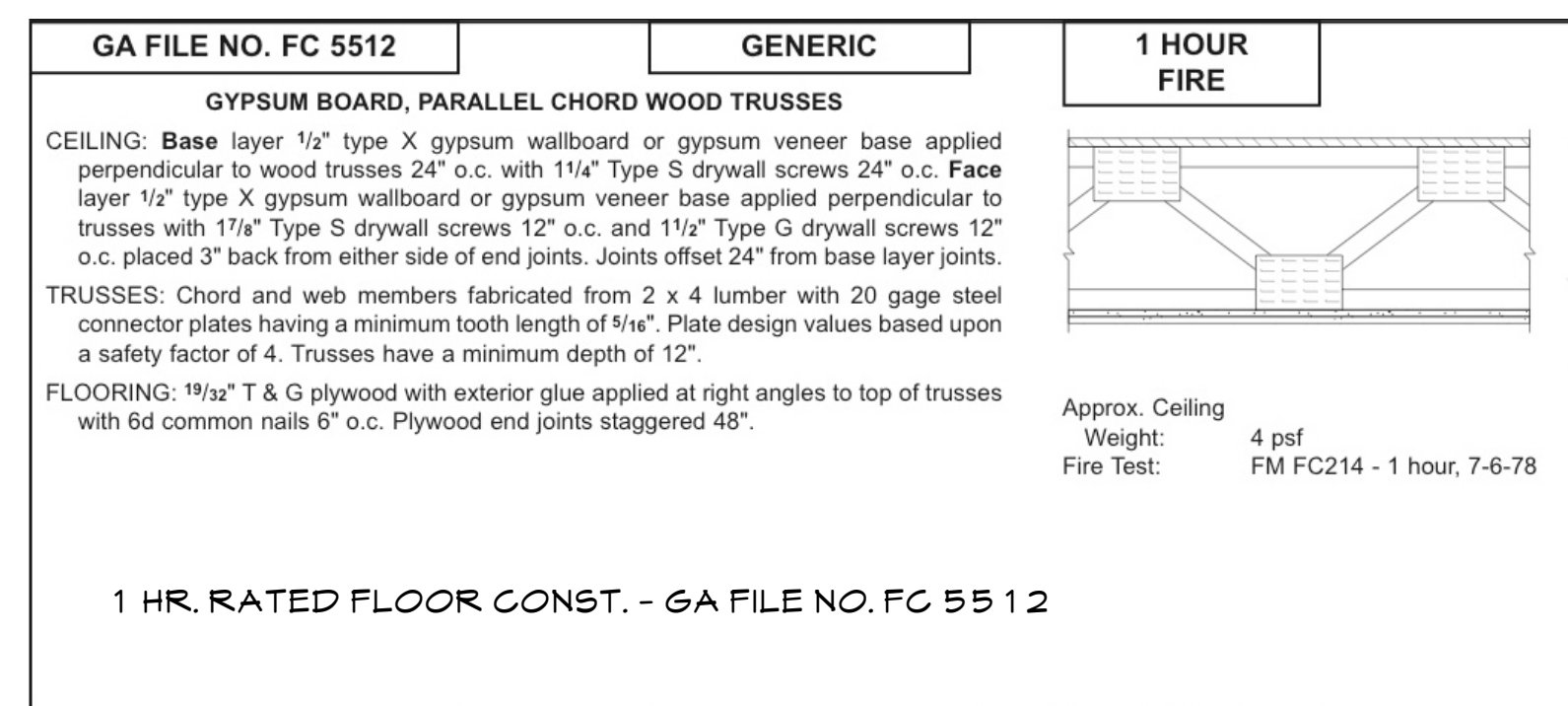
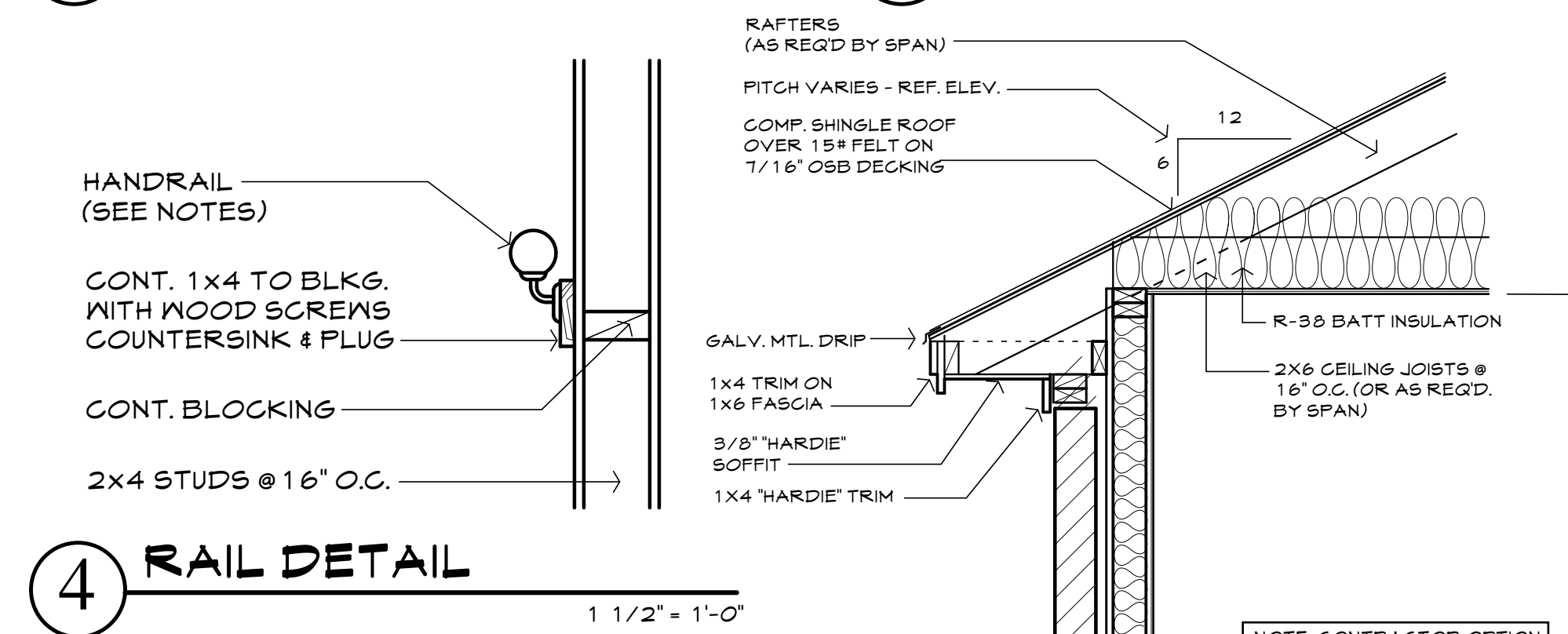
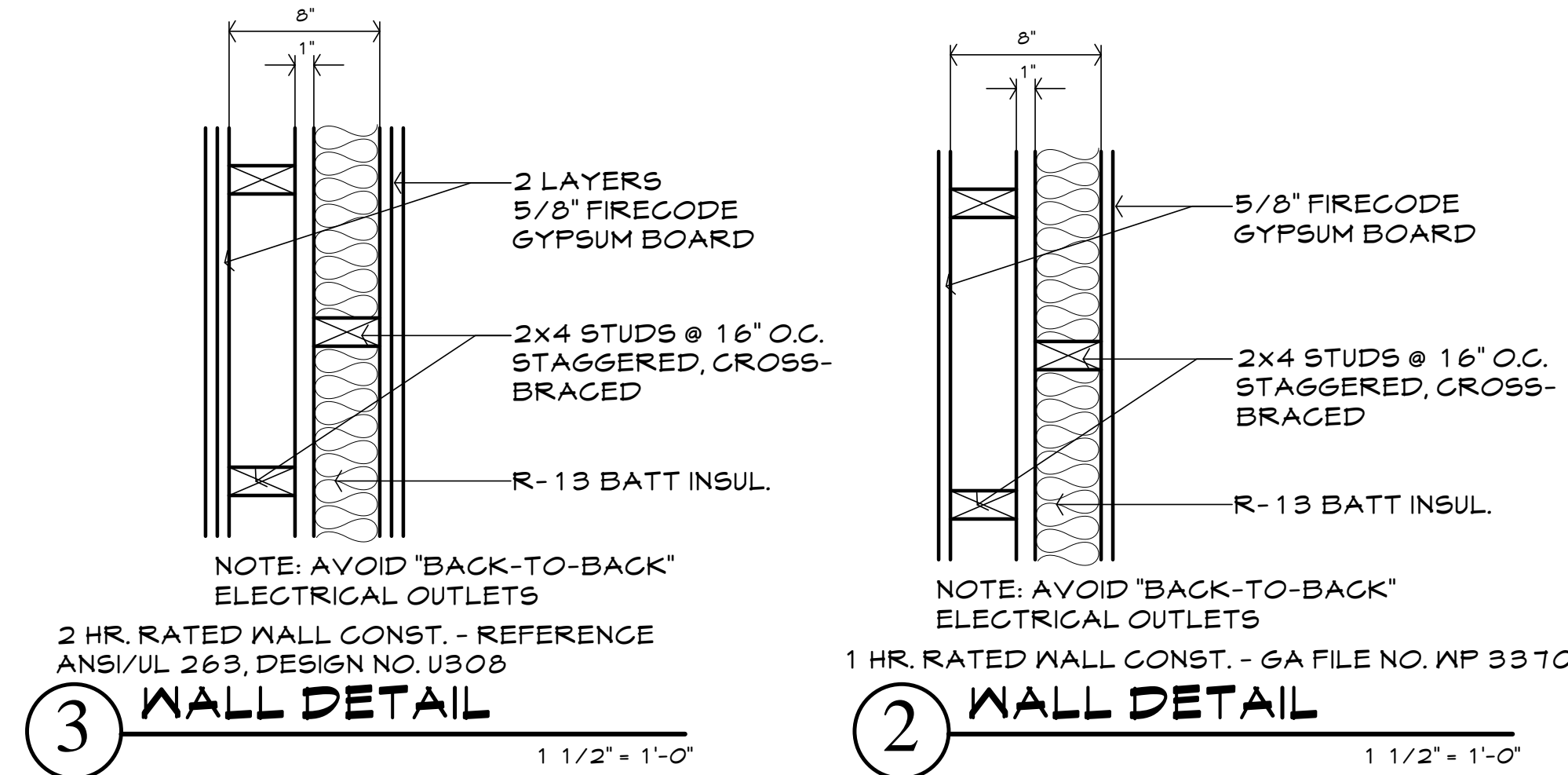

HANDRAIL NOTES

- Handrails shall be provided on both sides of stairs. Handrails shall be continuous within the full length of each stair flight. Inside handrails on switchback or dogleg stairs shall be continuous between flights.
- Top of gripping surfaces of handrails shall be 3 1/2 inches min. and 3 3/4 inches max. vertically above walking surfaces and stair nosings. Handrails shall be at a consistent height above walking surfaces and stair nosings.
- Clearance between handrail gripping surfaces and adjacent surfaces shall be 1 1/2 inches minimum.
- Handrail gripping surfaces shall be continuous along their length and shall not be obstructed along their tops or sides. The bottoms of handrail gripping surfaces shall not be obstructed for more than 20 percent of their length. Where provided, horizontal projections shall occur 1 1/2 inches min. below the bottom of the handrail gripping surface.
- Handrail gripping surfaces with a circular cross section shall have an outside diameter of 1 1/4 inches min. and 2 inches max. Handrail gripping surfaces with a non-circular cross section shall have a perimeter dimension of 4 inches min. and 6 1/4 inches max. and a cross-section dimension of 2 1/4 inches max.
- Handrail gripping surfaces and any surfaces adjacent to them shall be free of sharp or abrasive elements and shall have rounded edges. Handrails shall not rotate within their fittings.
- At the top of a stair flight, handrails shall extend horizontally above the landing for 12 inches min. beginning directly above the first riser nosing. Extensions shall return to a wall, guard, or the landing surface, or shall be continuous to the handrail of an adjacent stair flight.
- At the bottom of a stair flight, handrails shall extend at the slope of the stair flight for a horizontal distance at least equal to one tread depth beyond the last riser nosing. Extension shall return to a wall, guard, or the landing surface, or shall be continuous to the handrail of an adjacent stair flight.

WINDOW NOTES

- All windows shall comply with 2012 IECC for U-Factor and SHGC
- All glazing shall be minimum 5/8" low E insulating glass
- All glazing within 2'-0" of ext. doors shall be tempered
- All windows are single-hung unless otherwise noted
- Bedroom windows shall provide a 5.7 s.f. net clear opening (minimum of 2'-0" high and 1'-8" wide)
- Dwelling unit window sills shall be a minimum of 3'-0" AFF

ACCESSIBILITY NOTES Public spaces and 2-2 "HC" unit

- All public and common use spaces must be readily accessible to and useable by people with disabilities.
- 2-2 "HC" unit must comply with requirements of a "Type A Dwelling Unit" as defined in the 2012 IBC and ICC A 111.1.
 - Unit must have all the required accessible clearances and blocking in the walls around the toilet and tub for grab bars.
 - The toilet needs to be in the corner and 18" O.C. from an adjacent wall and 15" from the lavatory on the other side.
 - A 60" circular clear floor turning space or T-shaped space (section 304 of ANSI) and 30"x40" clear space for the tub and lavatory is required to be provided.
 - The front door, bedroom door and bathroom door must be 36" wide.
- Unit door hardware shall be lever type (ANSI A 111.1-14.9.8)
- Unit corridors shall be 36" minimum clear width.
- Mount entry door hardware at a height of 4'-0" max. above finish floor. Security viewer (peephole) to be located in the center of the door at a height of 5'-8" max. above finish floor. Dead bolt locks and lever hardware shall comply with ANSI A 111.1-14.2.7.
- Unit thresholds shall not be more than 3/4" with changes beveled at a slope less than 1:2.
- The landing surface at the entry door to the unit shall be no more than 1/2" below finish floor. Provide minimum slope for drainage.
- Floor surface shall not be more than 1/2" below finish floor.
- Unit interior doors shall require no more than 5 lb. opening force.
- The 2-2 "HC" unit must be constructed for accessibility in accordance with ICC A 111.1.

OUTLINE SPECIFICATIONS

- All work shall be accomplished in accordance with the City of College Station building codes.
- Cut and fill as required to accomplish the details and levels indicated on the Drawings and as required to provide drainage.
- Landscaping shall comply with all City of College Station requirements and include an underground irrigation system and seeding of entire lot.
- Cabinets shall be stain-grade and provided where indicated on the drawings.
- Countertops in Kitchen and Bathrooms shall be 3/4" thick granite.
- Insulation shall be blown-in cellulose: R-30 in ceiling; R-19 in walls.
- Roof decking shall be 7/16" thick with radiant barrier
- Composition shingles shall be 240 lb. per square, self-sealing shingles. "Energy-Star" rated reflective shingles as manufactured by Certainteed corporation or approved equal.
- Exterior passage doors shall be 1 3/4" thick insulated doors as manufactured by Eagle or equal.
- Typical interior doors shall be 1 3/8" thick hollow core, two panel doors as manufactured by Lone Star Plywood or equal. All 1-1 units shall have French doors with frosted glass as indicated on the Drawings.
- Hardware shall be provided for all interior and exterior doors and cabinets.
- Windows shall be low-E insulating glass in vinyl frames.
- Provide mirrors in each restroom. Mirrors shall be 42" high and extend full length of vanities.
- Gypsum board (5/8" thick) shall be applied to all interior walls and ceilings, taped and floated.
- Vinyl plank flooring shall be provided in Bathrooms, Kitchen, Living and Hallways and shall be equal to "Luxe Plank" as manufactured by Armstrong.
- Carpet shall be cut-pile, minimum 24 ounce per yard and installed with foam pad.
- Paint shall be low VOE, equal to products manufactured by Sherwin Williams.
- Toilet accessories shall include one toilet paper holder and two towel bars in each restroom.
- Kitchen appliances shall be provided by cash allowance.
- Bathrooms and shower surrounds shall be cultured marble.
- Plumbing shall comply with all City of College Station requirements. Waste and vent piping shall be Schedule 40 PVC. Cold water piping shall be copper tubing without joints, under slab and for entry into the building. Hard copper tubing and fittings will be used for all other cold water lines. Hot water piping shall be Type L hard copper tubing with wrought coppler fittings joined with high temperature solder.
- Disposals shall be provided at all kitchen sinks. No ice makers are required.
- Space conditioning work shall conform to applicable rules and regulations of the City of College Station, Texas and other governing authorities. Combination heating and cooling system employing electric air conditioning and electric heating; attic mounted air handler and pad mounted air cooled outside unit. Manufacturer to be Lennox or Carrier with a SEER of 14 or greater.
- Electrical work shall conform to applicable rules and regulations of the City of College Station, Texas and other governing authorities. The power source for all electrical installations in this project is College Station Utilities. Furnish and install new electrical panel in each unit. Light fixtures safety switches, light switches, receptacles and wall plates in full compliance with the National Electric Code requirements.
- All interior lighting shall be compact fluorescent.

CODE INFORMATION

Heated area: See building plans

Governing Codes:
International Building Code, 2012 Edition
International Mechanical Code, 2012 Edition
International Plumbing Code, 2012 Edition
National Electrical Code, 2009 Edition

Occupancy: Residential "R2"

Occupancy separation requirement; 1 hour

Allowable height/area: 3 story / 12,000 s.f.

Construction type: V-A.

Fire Resistance Rating Requirements:
Structural Frame; 1 hour
Bearing Exterior Walls; 1
Bearing Interior Walls; 1
Nonbearing Interior Walls; 0
Nonbearing Exterior Walls; 1
Floor Construction; 1
Roof Construction; 1

Fire Partitions: 1 hr. partition required between dwelling units

Horizontal Assemblies: 1 hr. floor assembly required between dwelling units

Concealed Spaces: Fireblocking and draftstopping required
Batt insulation allowed as fireblocking in double stud walls

Interior Finishes: Class "C" in rooms and enclosed spaces

Stairways and Handrails: Comply with Section 1009 (see handrail notes)

Comply with the Fair Housing Amendments Act of 1998

Dwelling units shall have heat pump HVAC units.

ENERGY CODE INFORMATION

BUILDING AREA	GROSS WALL AREA	FENESTRATION AREA	RATIO OF FENESTRATION TO WALL AREA
BUILDING A 1B	6,435 s.f.	910 s.f.	.14
BUILDING C	2,608 s.f.	260 s.f.	.09
BUILDING D	11,265 s.f.	1,690 s.f.	.15
BUILDING E	10,501 s.f.	1,520 s.f.	.14
BUILDING F	5,186 s.f.	630 s.f.	.12
BUILDING G	4,036 s.f.	450 s.f.	.11

IN ACCORDANCE WITH CHAPTER 5 OF THE INTERNATIONAL ENERGY CONSERVATION CODE AND BASED ON THE PRESCRIPTIVE BUILDING ENVELOPE REQUIREMENTS FOR BRYAN/COLLEGE STATION AREA, THE FOLLOWING SPECIFICATIONS WILL APPLY:

TABLE 502.2.4(2), MAX. 12% RATIO	MAX. SOLAR HEAT GAIN COEFF.	MAX. GLAZING 'U' FACTOR	MIN. EXTERIOR WALL 'R' VALUE	MIN. CEILING 'R' VALUE	MIN HVAC SEER VALUE
	0.25	0.65	R-13	R-30	13 SEER

FRAMING NOTES

- The following notes set forth minimum requirements for framing. All final decisions on the framing are the responsibility of the Builder. Consult with a structural engineer as necessary.
- All bottom plates that contact concrete shall be GCA "treated" lumber.
- Exterior wall studs shall be 2x6 at 16" on center. Interior wall studs shall be 2x4 at 16" on center.
- 1x4 yellow pine "let-in wind-bracing" shall be used in all interior walls wherever possible. Typically, interior walls longer than 8' shall include a diagonal wind-brace.
- Exterior sheathing shall be 7/16" oriented strand board with applied house wrap.
- Headers, joists and rafters shall be sized according to the Span Table.
- All ridges, hips, and valleys shall be one size larger than the rafters.
- Roof system shall include 7/16" OSB, 15# felt, and 25 yr. dimension composition shingles.
- Blocking shall be provided in appropriate locations.
- Provide 2x6 rafter ties at all plates where joists run perpendicular to rafters.
- Provide 2-2x6 strong back at spans over 10'-0"
- Fascia shall be 1x4 "Hardie" trim with 1x2 metal edging on 1x6 "Hardie" fascia board.
Soffits shall be 3/8" AC "Hardie" soffit with 8"x16" soffit vents at 8'-0" o.c.
- HVAC subcontractor shall design HVAC system and duct layouts. HVAC and plumbing subcontractors shall coordinate any special framing requirements such as attic equipment platforms, attic walkways, furr-downs, etc. with the framing subcontractor.
- HVAC subcontractor shall install required appliance vent ducting and other misc. ducting according to industry standards and manufacturer's recommendations.

SPAN TABLE Southern Forest Products specifications for no. 2 grade fir or yellow pine

CEILING JOISTS	FLOOR JOISTS	RAFTERS	HEADERS
(LIMITED ATTIC STORAGE) 2x6 at 16" O.C. = 13'-2" 2x8 at 16" O.C. = 11'-5" 2x10 at 16" O.C. = 20'-9"	(40 psf LIVE LOAD) 2x12 at 24" O.C. = 15'-4" 2x12 at 16" O.C. = 18'-10" 2x12 at 12" O.C. = 21'-7"	(SLOPES OVER 3:12) 2x6 at 24" O.C. = 11'-4" 2x6 on edge = 4'-6" 2x6 at 16" O.C. = 13'-11" 2x6 at 12" O.C. = 16'-1"	2-2x4 on edge = 3'-6" 2-2x6 on edge = 4'-6" 2-2x10 = 7'-6" 2-2x10 on edge = 7'-6"

HEADER SCHEDULE #2 Y.P. or better

SPAN (MAX.)	3'-6"	6'-0"	8'-0"	12'-0"	14'-0"
HEADER SIZE	2-2x4	2-2x6	2-2x8	2-2x10	2-2x12

ALL WINDOW AND DOOR HEADERS ON THE FIRST FLOOR ARE TO BE 2-2X12
Use 2-2x12 with 1/2" steel fillet plate, thru bolted for spans up to 20'-0"
Use 2-2x12 with 1/2" plywood, glued and nailed for spans up to 16'-0"

LINTEL SCHEDULE Minimum 4" bearing to each side

SPAN (MAX.)	5'-0"	7'-0"	8'-0"	9'-0"	10'-0"
ANGLE SIZE	3.5" x 3.5" x 5/16" THK.	4" x 3.5" x 5/16" THK.	5" x 3.5" x 5/16" THK.	5" x 3.5" x 3/8" THK.	6" x 3.5" x 3/8" THK.

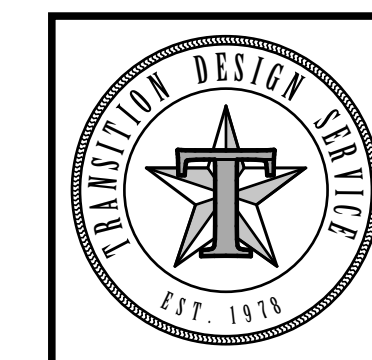

COPPER CREEK CONDOS
COLLEGE STATION TEXAS

Transition Design Service
201 W. Villa Maria Road * Bryan, Texas 77801 * (979) 822-7777

DATE: SEPT. 2014

A 10

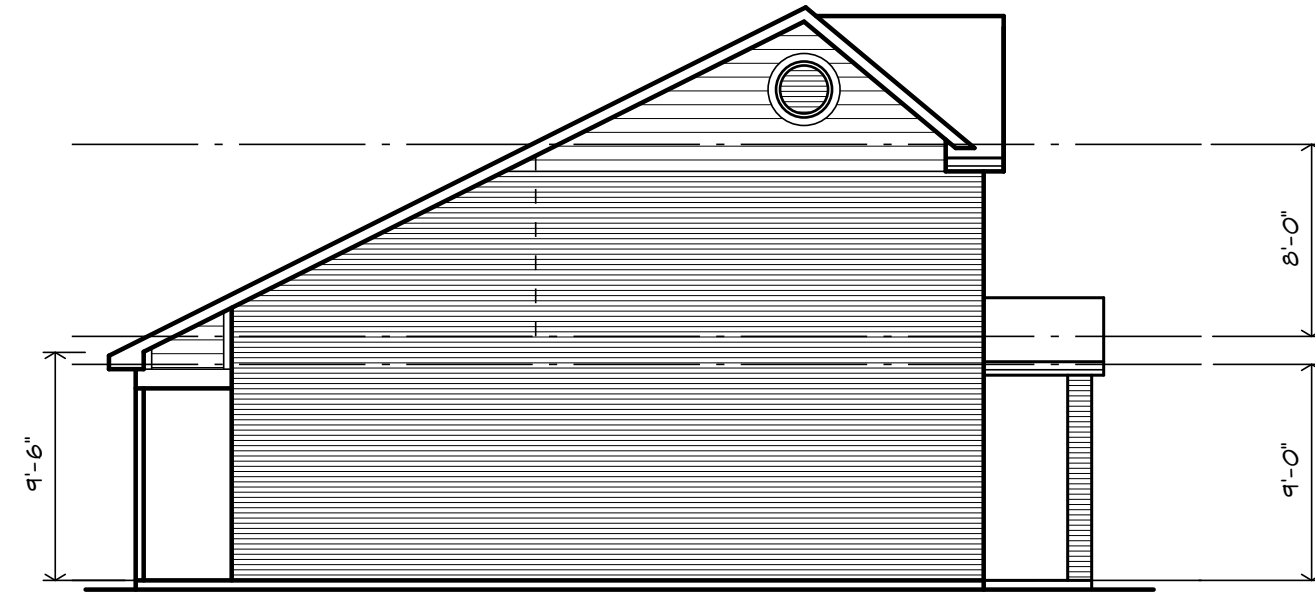

6 BLDG. A, B & C - LEFT SIDE ELEV. $1/8" = 1'-0"$
BLDG. A - PHASE 1

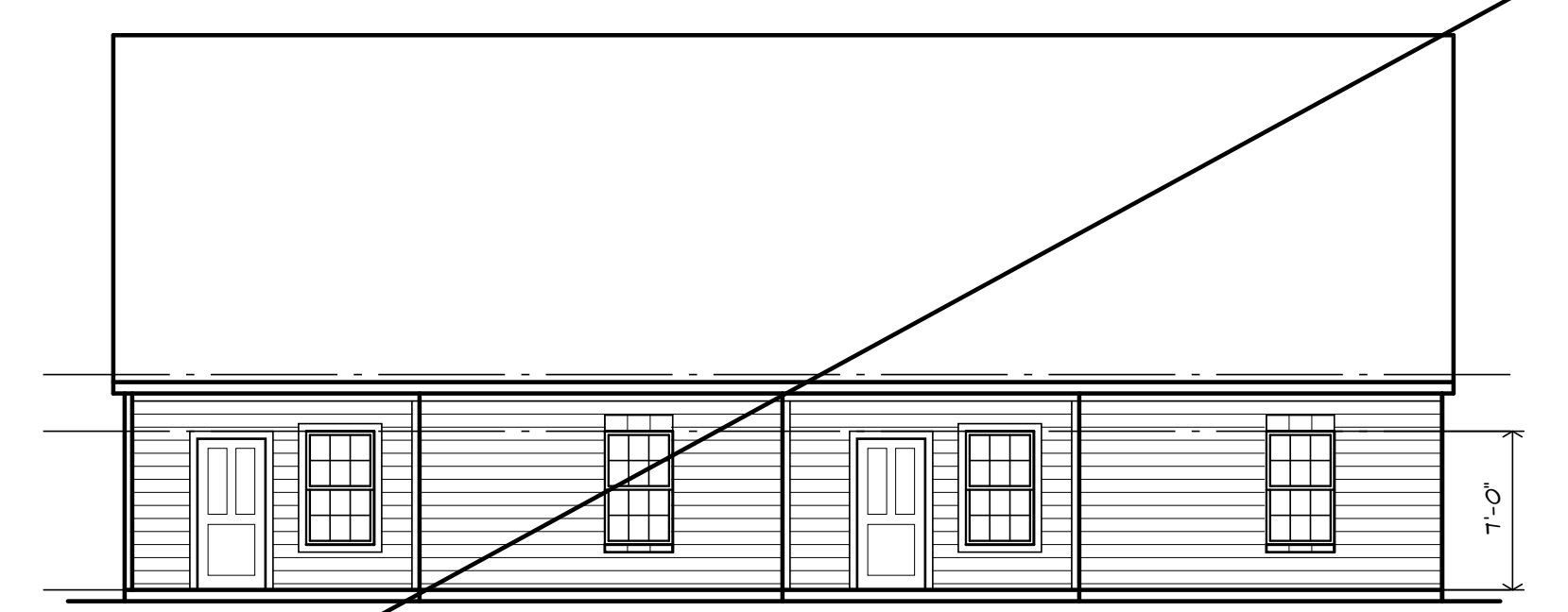

4 BLDG. C - BACK ELEVATION $1/8" = 1'-0"$

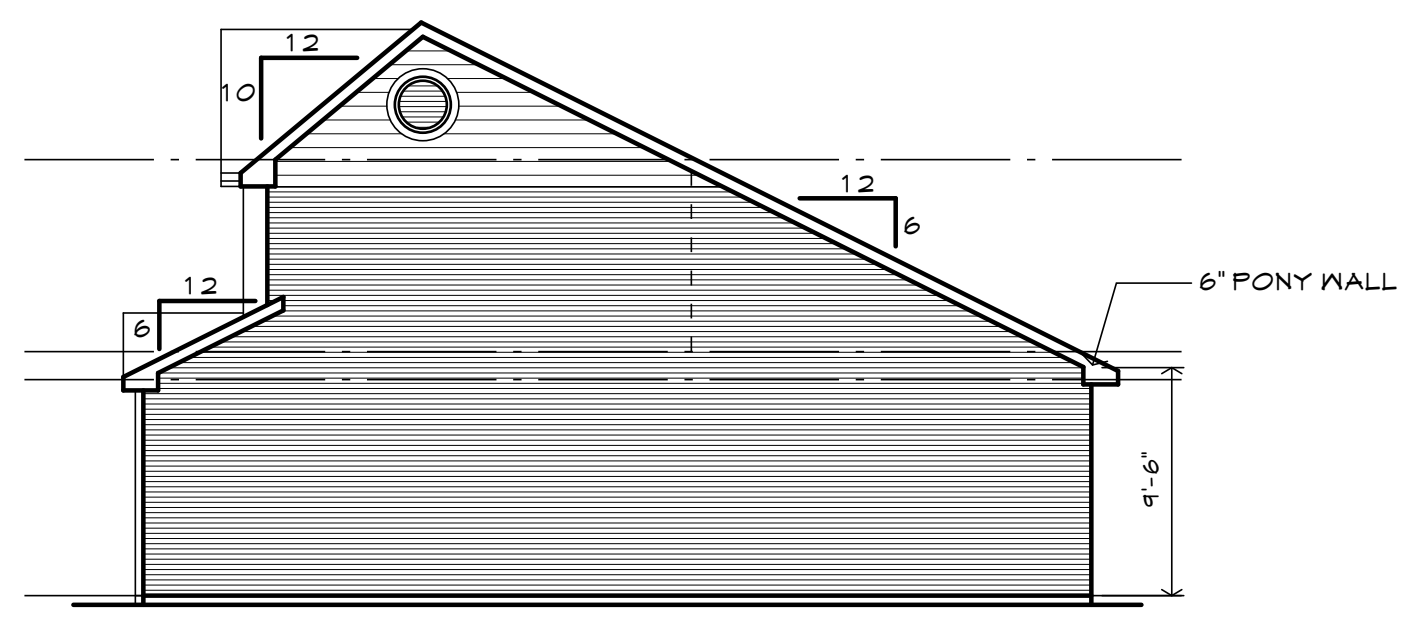

5 BLDG. A, B & C - RIGHT SIDE ELEV. $1/8" = 1'-0"$
BLDG. A - PHASE 1



3 BLDG. C - FRONT ELEVATION $1/8" = 1'-0"$



2 BLDG. A & B - BACK ELEVATION $1/8" = 1'-0"$
BLDG. A - PHASE 1



1 BLDG. A & B - FRONT ELEVATION $1/8" = 1'-0"$
BLDG. A - PHASE 1

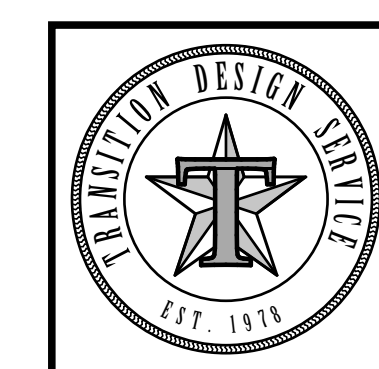

COPPER CREEK CONDOS
COLLEGE STATION TEXAS
Transition Design Service
201 W. Villa Maria Road * Bryan, Texas 77801 * (979) 822-7777

DATE: SEPT. 2014
A 1 1

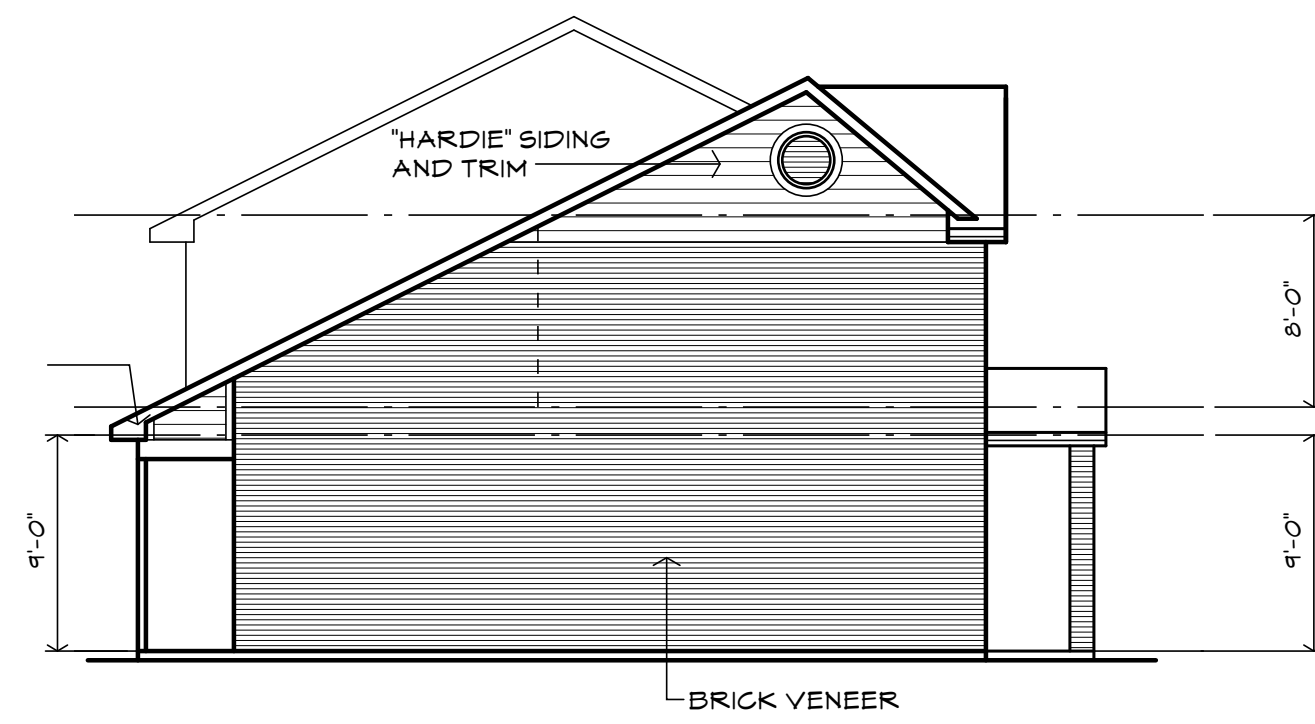

5 BLDG. E - LEFT SIDE ELEV. 1/8" = 1'-0"

PHASE 1

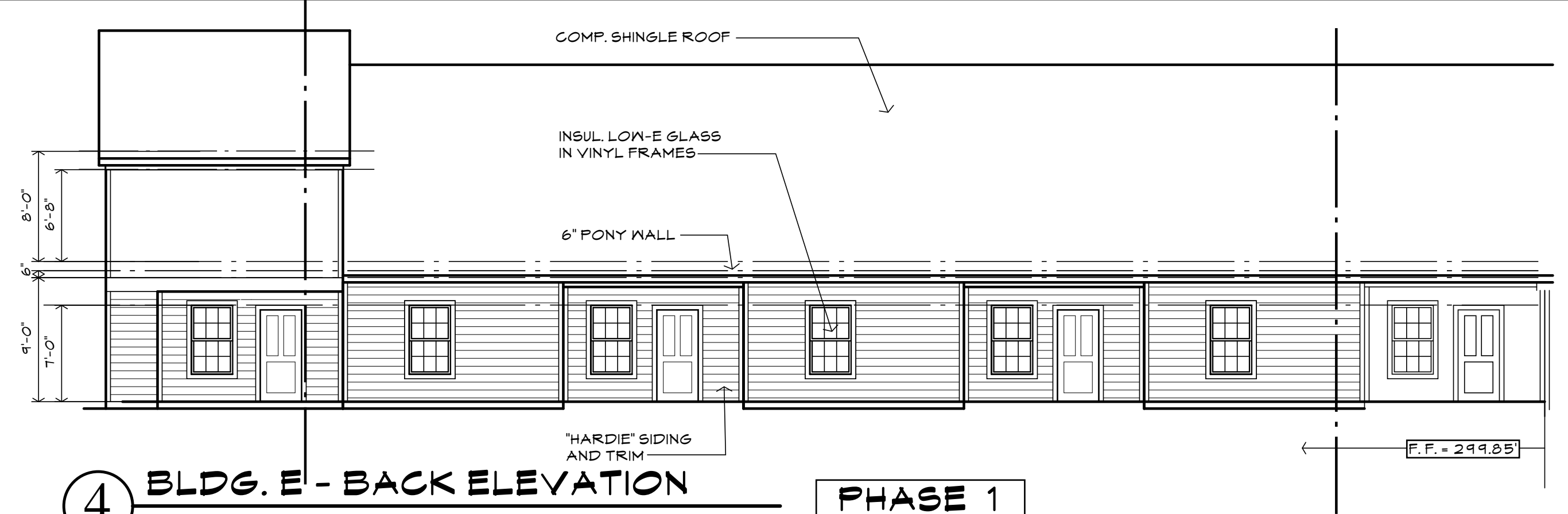

4 BLDG. E - BACK ELEVATION 1/8" = 1'-0"

PHASE 1

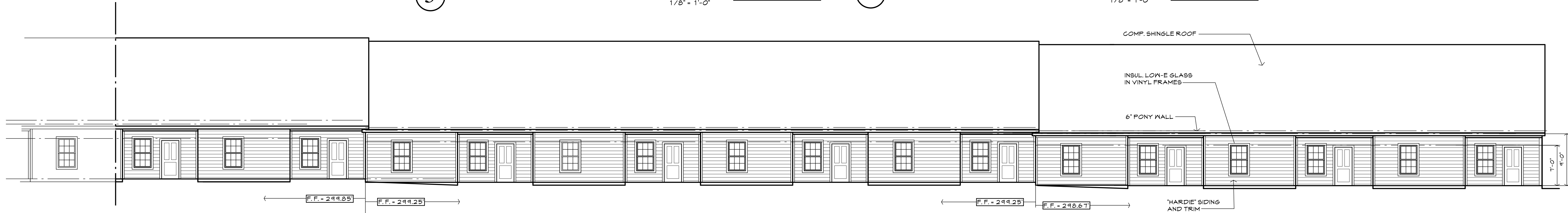

3 BLDG. E - BACK ELEVATION 1/8" = 1'-0"

PHASE 1

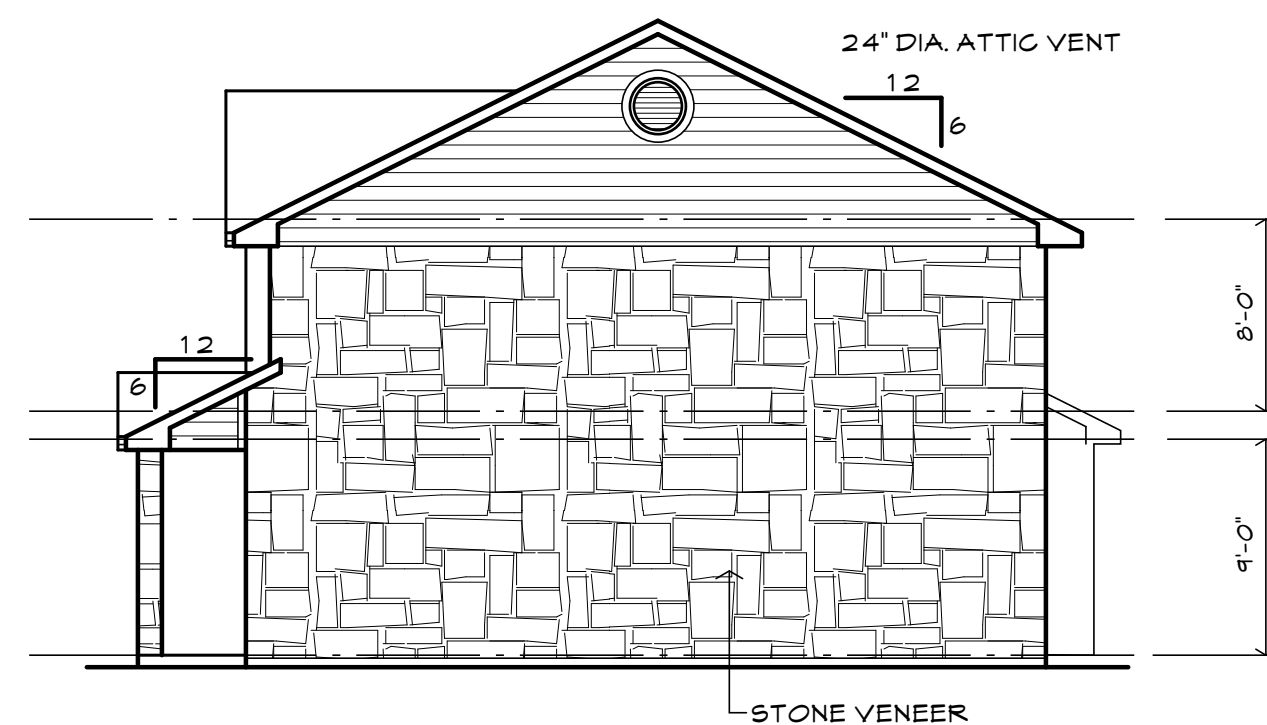

6 BLDG. E - RIGHT SIDE ELEV. 1/8" = 1'-0"

PHASE 1

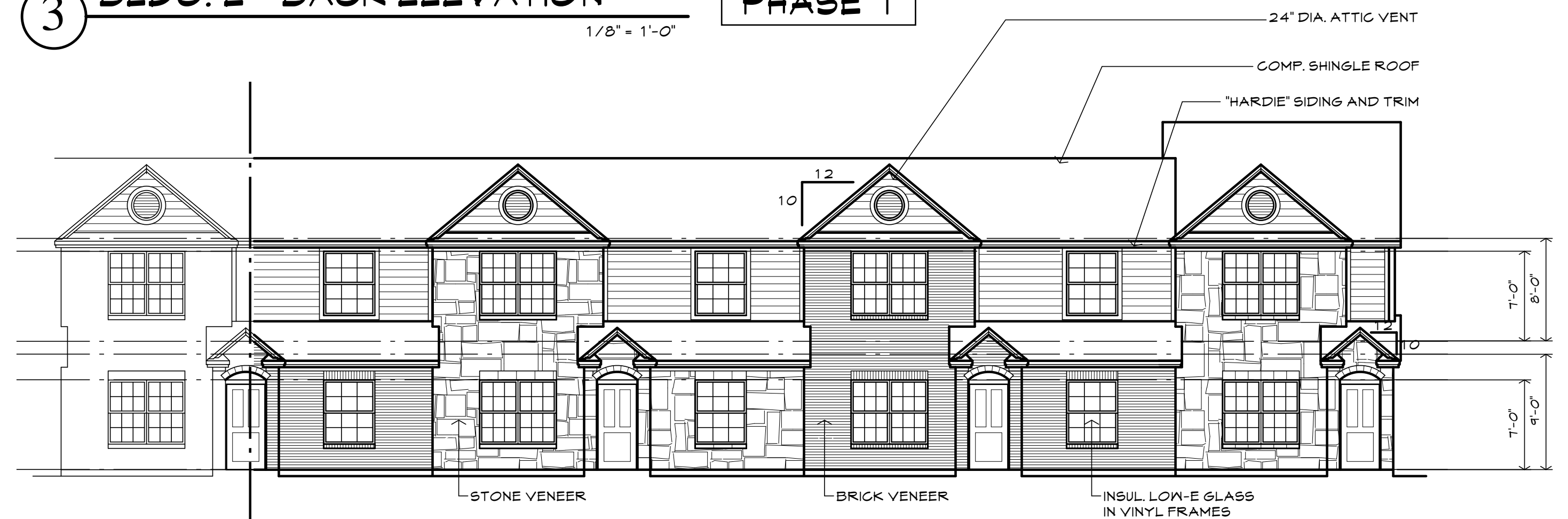

2 BLDG. E - FRONT ELEVATION 1/8" = 1'-0"

PHASE 1



1 BLDG. E - FRONT ELEVATION 1/8" = 1'-0"

PHASE 1



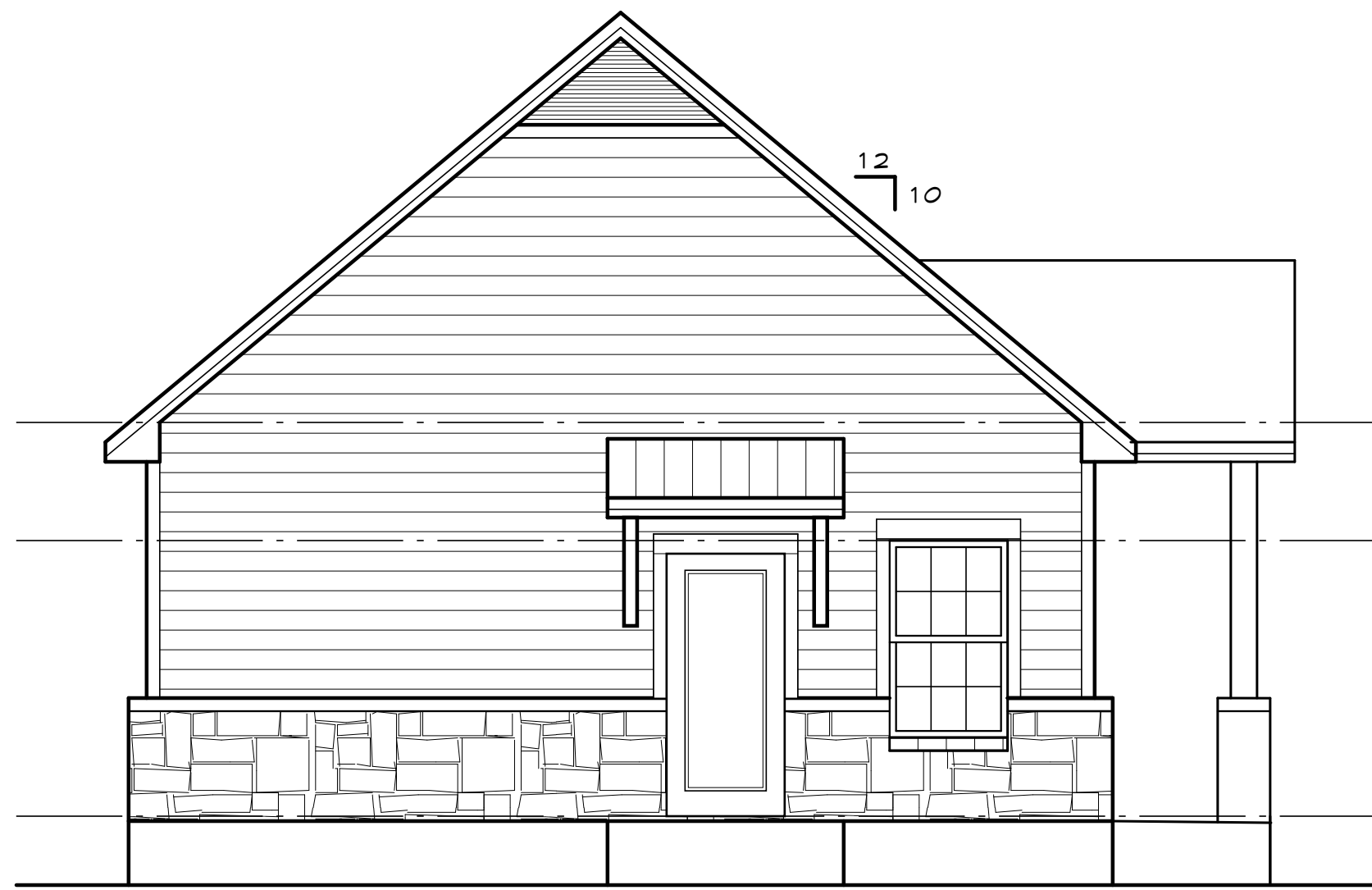

4 CLUB HOUSE SIDE ELEVATION
 1/4" = 1'-0"

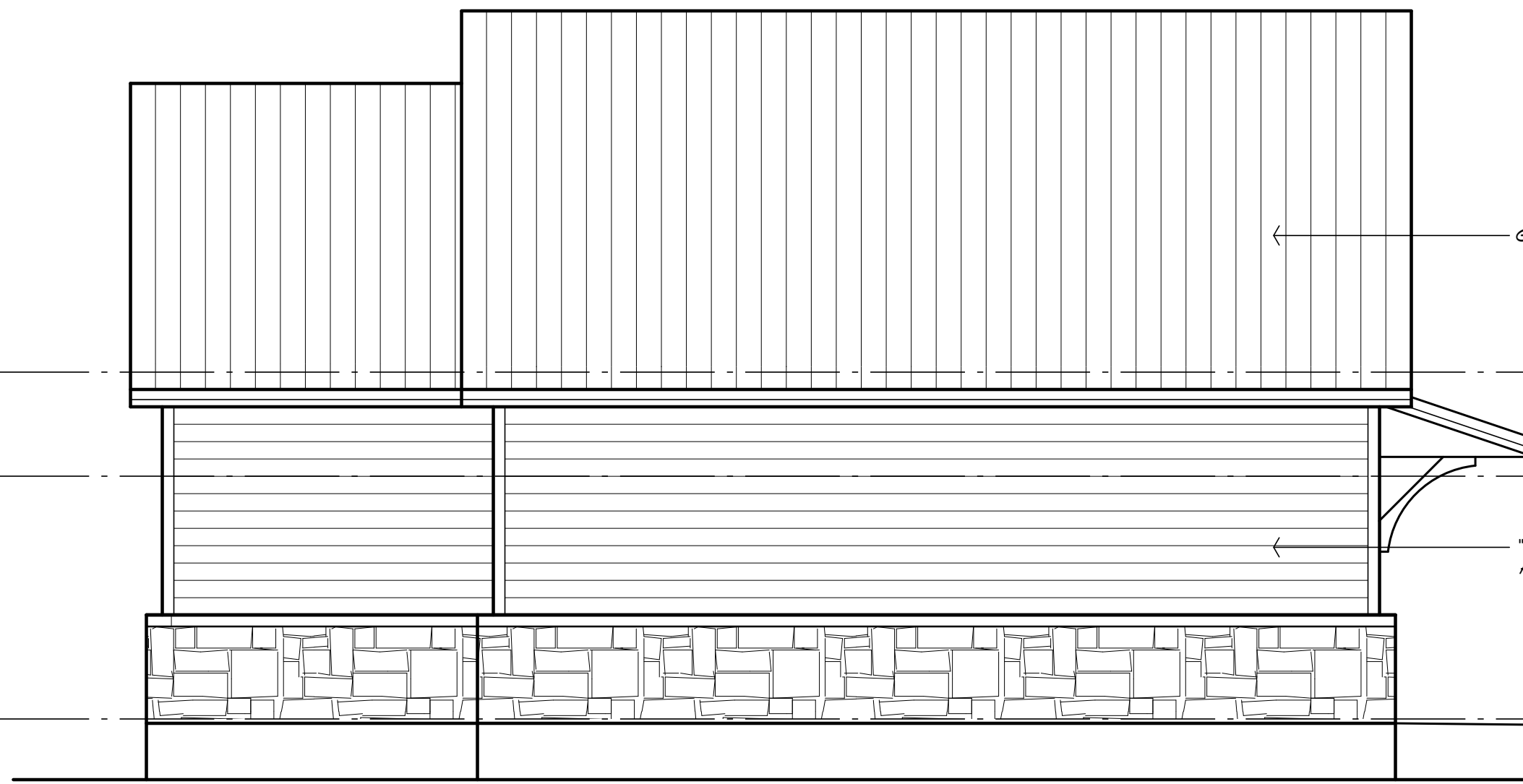

3 CLUB HOUSE BACK ELEVATION
 1/4" = 1'-0"



2 CLUB HOUSE FRONT ELEVATION
 1/4" = 1'-0"

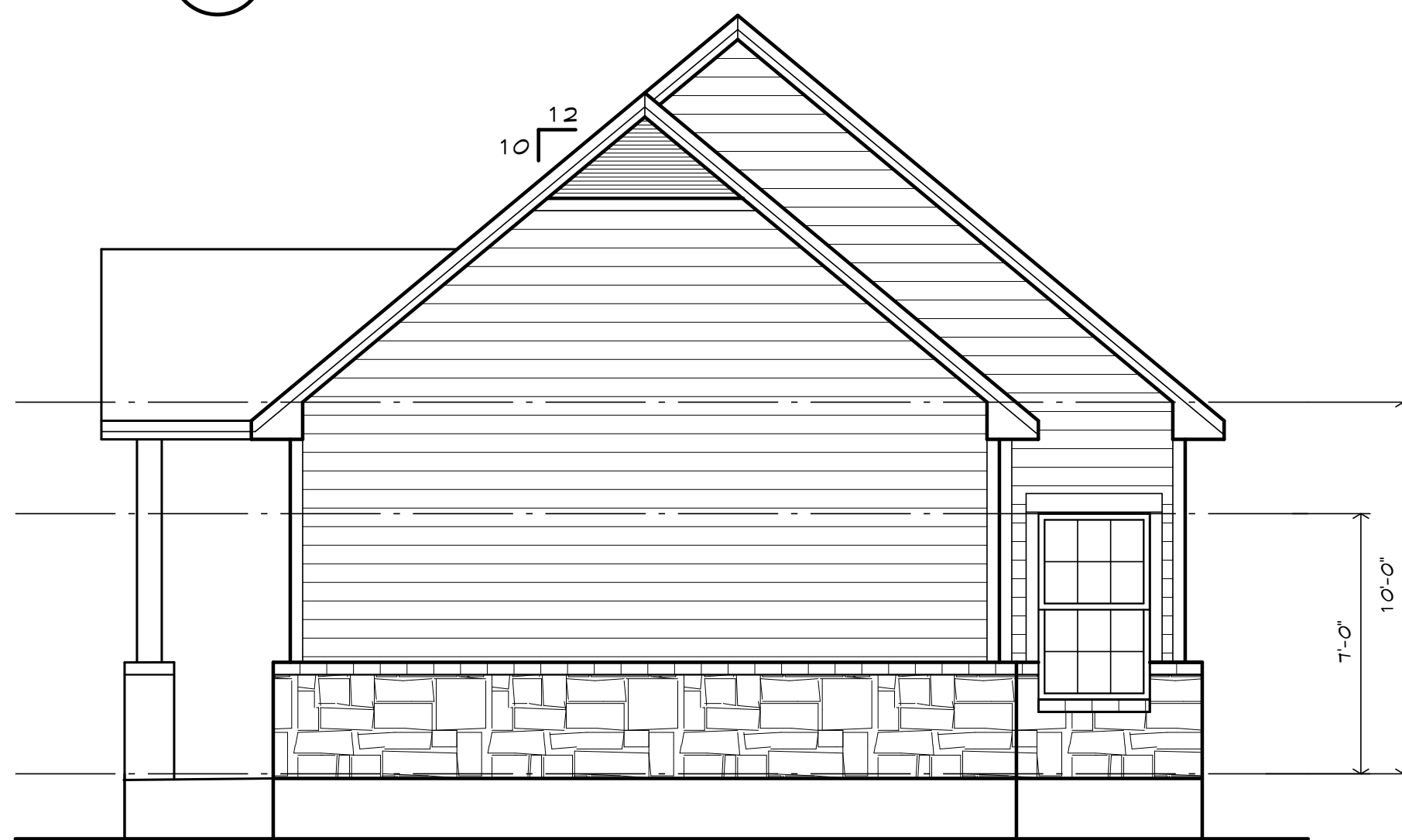

5 CLUB HOUSE SIDE ELEVATION
 1/4" = 1'-0"

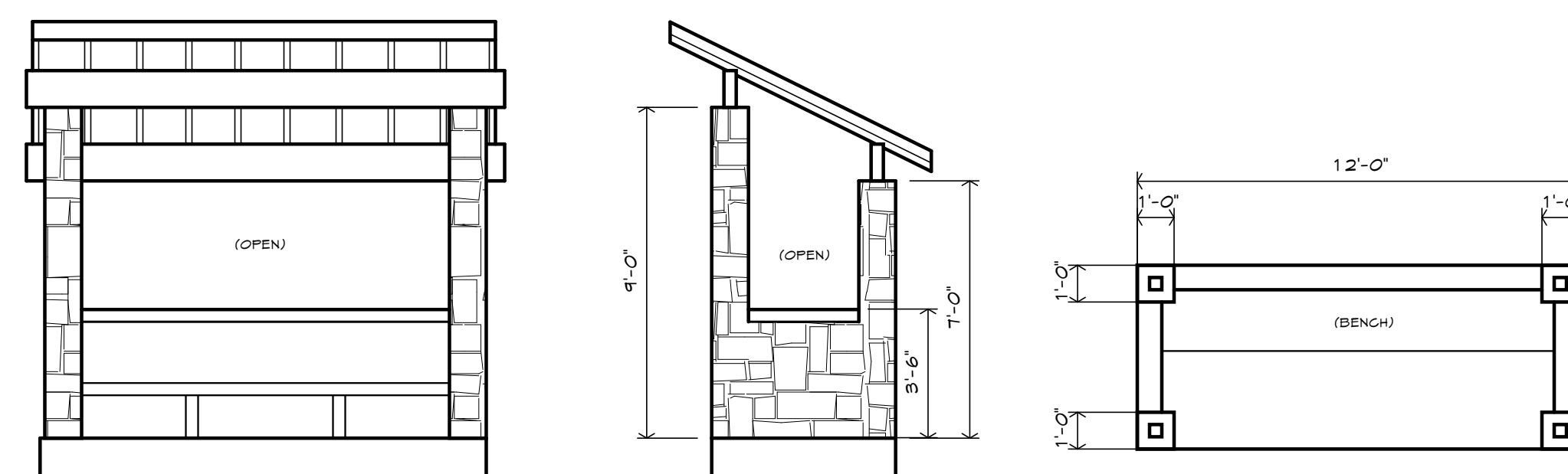

6 BUS STOP STRUCTURE
 1/4" = 1'-0"

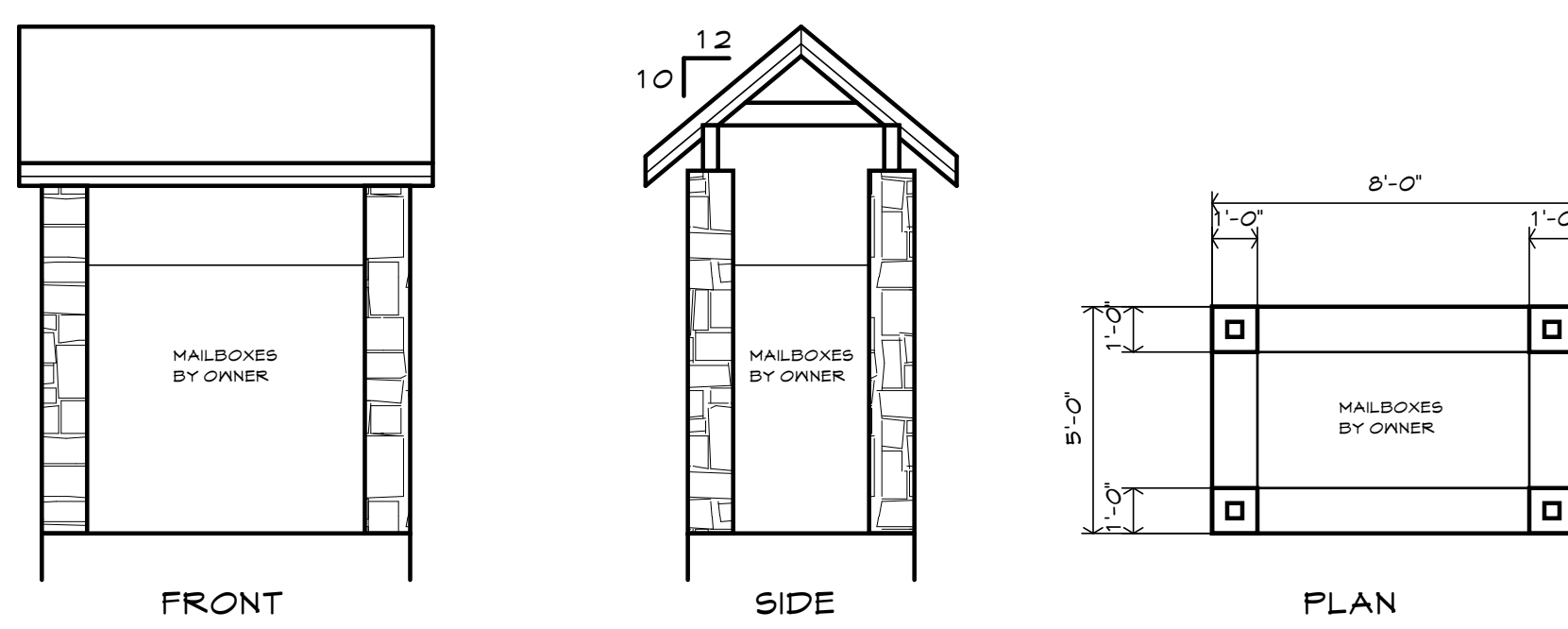

7 MAIL BOX STRUCTURE
 1/4" = 1'-0"

- SECURITY LIGHT
- DUPLEX OUTLET
- GFI
- W/P
- SPECIAL PURPOSE OUTLET
- TELEPHONE JACK
- CABLE OUTLET
- SWITCH
- 3-WAY SWITCH
- SURFACE MOUNTED INCANDESCENT
- PENDANT MOUNTED INCANDESCENT
- RECESSED INCANDESCENT
- EXHAUST FAN
- SMOKE DETECTOR
- CEILING FAN W/ LIGHT KIT

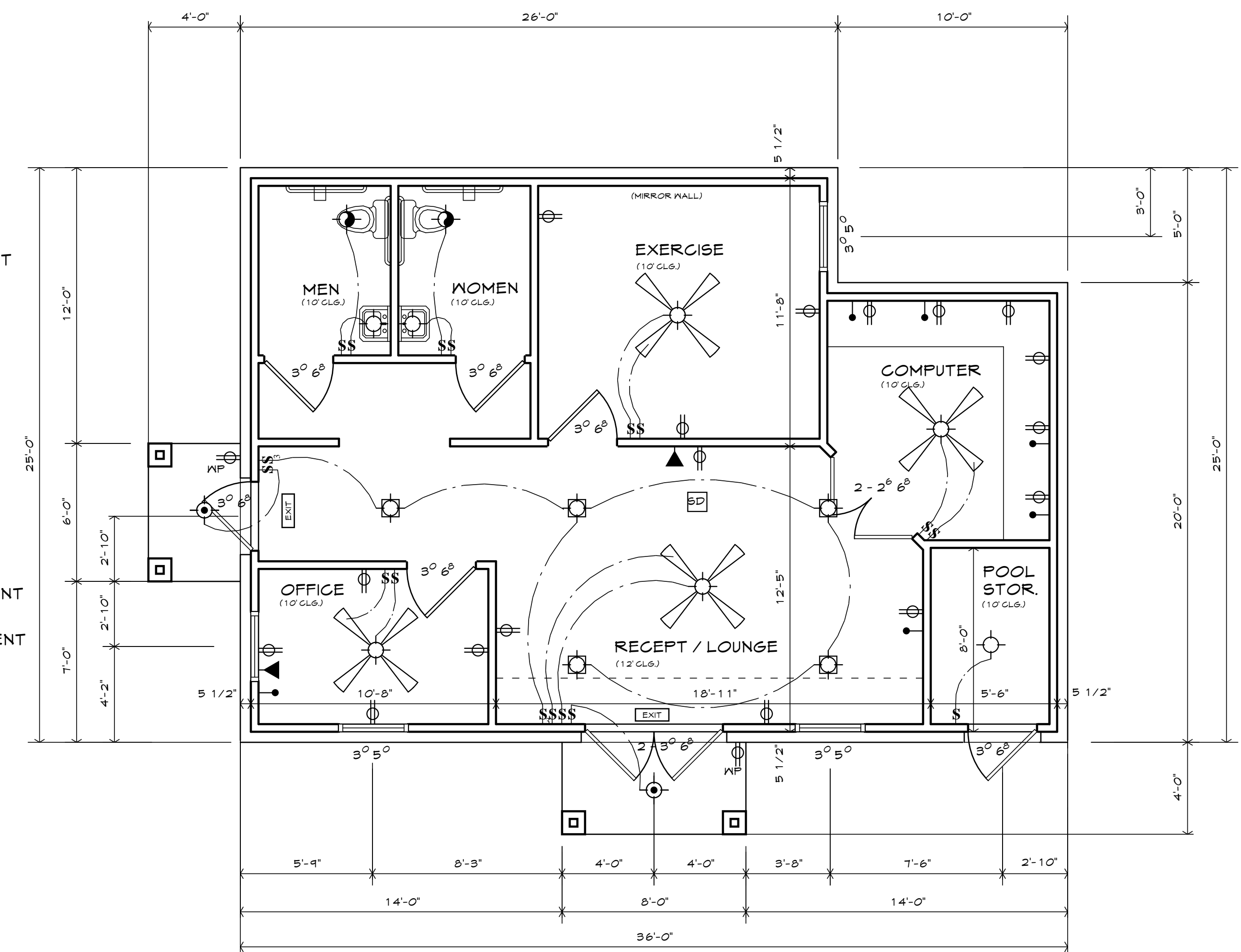

1 CLUB HOUSE FLOOR PLAN
 1/4" = 1'-0" PHASE 1

HEATED AREA INDICATED IS CALCULATED TO OUTSIDE FACE OF STUDS & DOES NOT INCLUDE BRICK VENEER, PORCHES OR BALCONIES

SLAB AREA: 906 s.f.
 HEATED AREA: 795 s.f.

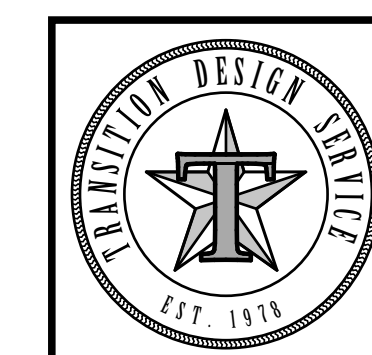

COPPER CREEK CONDOS
 COLLEGE STATION TEXAS
Transition Design Service
 201 W. Villa Maria Road * Bryan, Texas 77801 * (979) 822-7777

DATE: SEPT. 2014

A 15

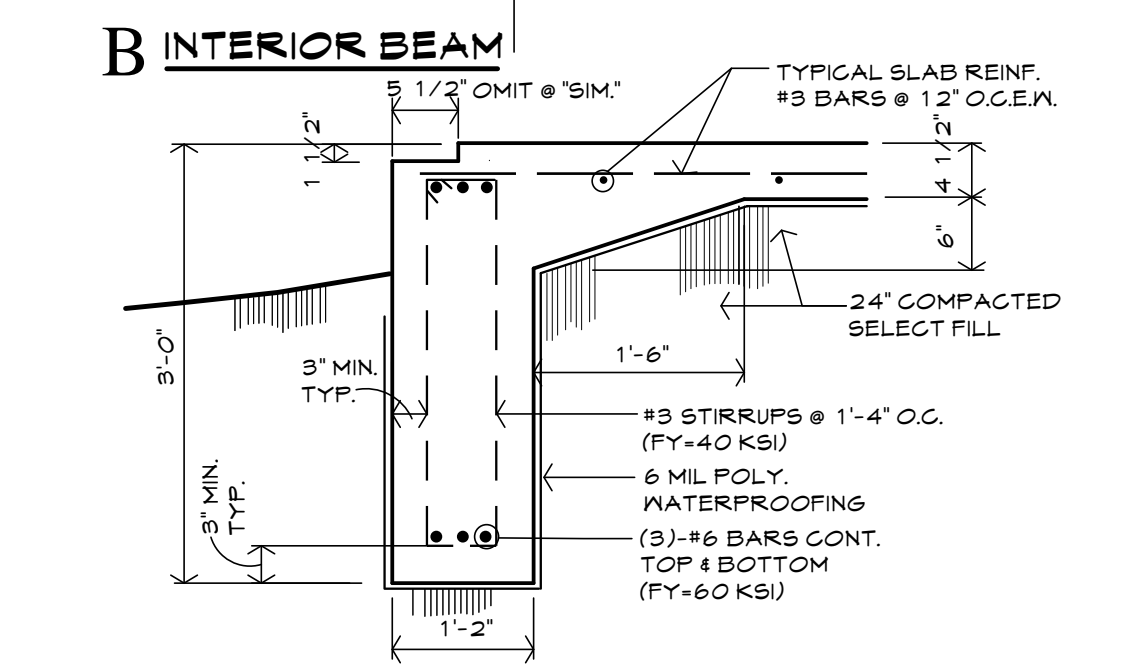
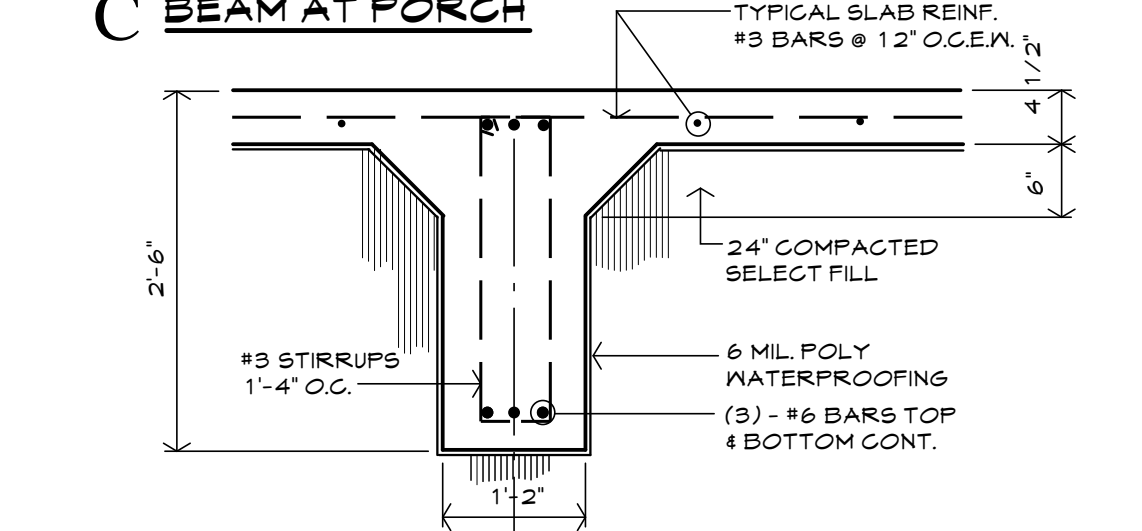
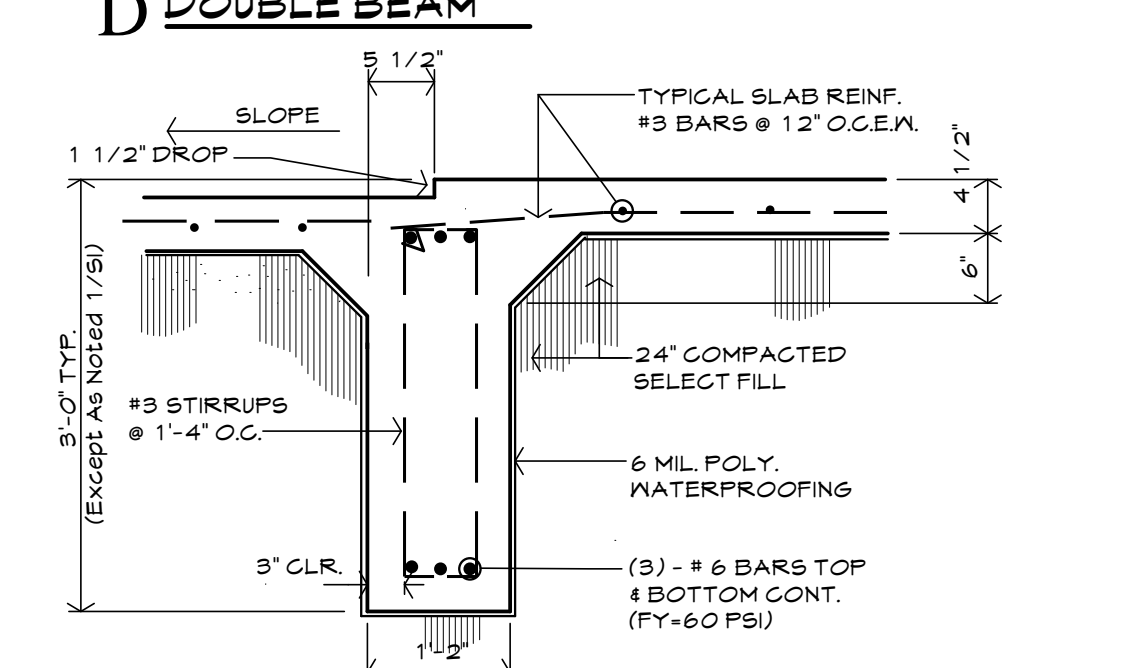
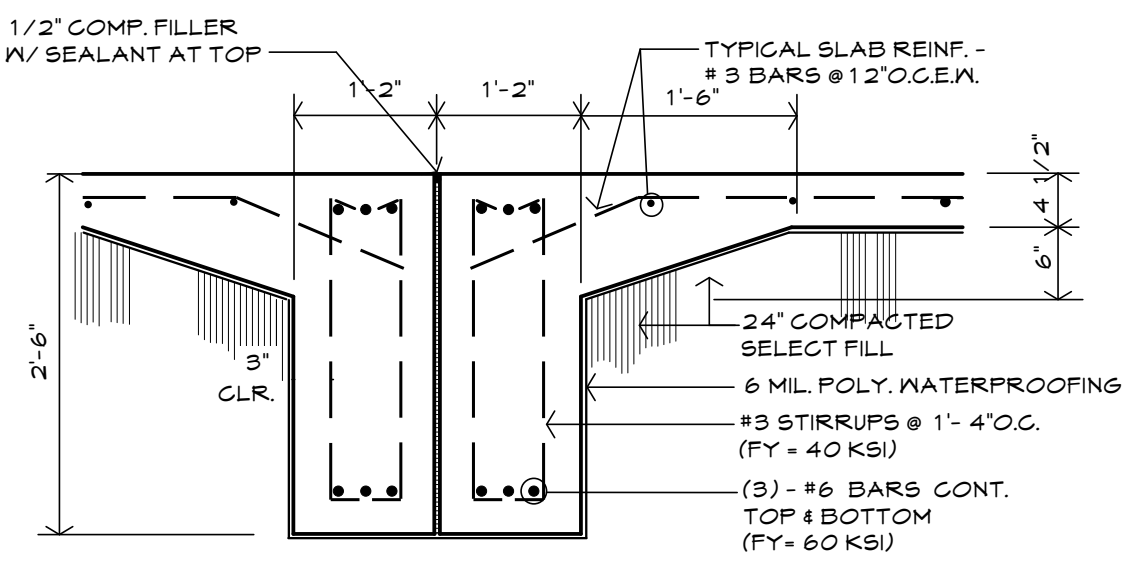
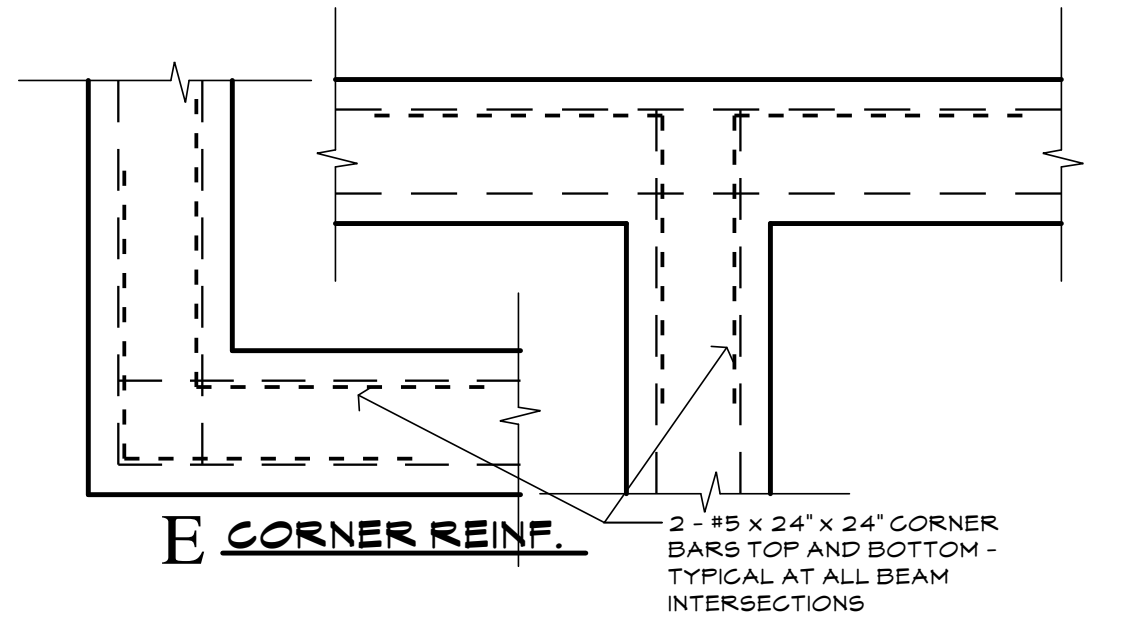

3 FOUNDATION DETAILS
NOTE: GRADE BEAMS TO EXTEND MIN. 1'-0" INTO UNDISTURBED SOIL
3/4" = 1'-0"

FOUNDATION SPECIFICATIONS

- GENERAL**
1. THE CONTRACTOR SHALL BE RESPONSIBLE FOR VERIFYING ALL DIMENSIONS PRIOR TO CONSTRUCTION AND FOR CHECKING ARCHITECTURAL VERSUS STRUCTURAL DIMENSIONS. THIS SHALL BE COMPLETED PRIOR TO COMMENCEMENT OF WORK. ANY DISCREPANCIES SHALL BE REPORTED TO THE ARCHITECT FOR CHECKING AND ALLOWANCES MADE FOR MINOR REVISIONS.
 2. REFER TO ARCHITECTURAL DRAWINGS FOR FLOOR ELEVATIONS, SLOPED OR DEPRESSED FLOOR AREAS, FINISHES, BRICK LEDGES, ETC.
 3. ALL SOIL UNDER SLAB SHALL BE TREATED WITH A 1% DURSBAN TERMITIC TREATMENT, OR EQUAL BY A CERTIFIED APPLICATOR.
 4. 6 MIL. POLYETHYLENE PLASTIC SHEETING SHALL BE RUN CONTINUOUSLY UNDER FOUNDATION AS A VAPOR BARRIER.
 5. 1/2" x 8" ANCHOR BOLTS SHALL BE PLACED ON 48" CENTERS FOR ALL EXTERIOR WALLS.
 6. FOUNDATION SHALL COMPLY WITH ALL CITY OF BRYAN REQUIREMENTS.
- EXCAVATION & FILL**
1. BOTTOMS AND SIDES OF EXCAVATIONS SHALL BE CLEANED BEFORE CONCRETE IS PLACED. ALL WATER OR OTHER DELETERIOUS MATERIALS AND LOOSE SOIL SHALL BE REMOVED FROM THE EXCAVATIONS PRIOR TO CONCRETE PLACEMENT. CONCRETE SHALL BE PLACED IN ALL FOOTINGS ON THE SAME DAY IN WHICH THEY ARE EXCAVATED AND MEASURES TO PREVENT EXCESSIVE DRYING OR MOISTENING OF THE EXCAVATION DURING THE TIMES OPENED SHALL BE TAKEN BY THE CONTRACTOR.
 2. PROVIDE 24" OF SELECT FILL. FILL MATERIAL SHALL BE FREE OF ANY ORGANIC, CLAY BALLS, OR OTHER DELETERIOUS MATERIALS. ONLY FILL WITH A FILLNESS THAN OR EQUAL TO 15 WILL BE ACCEPTABLE WITH SPECIFIED COMPACTION (A.S.T.M. D698).
- CAST-IN-PLACE CONCRETE**
1. ALL CONCRETE WORK SHALL BE IN ACCORDANCE WITH THE BUILDING CODE REQUIREMENTS FOR REINFORCED CONCRETE, ACI 318, LATEST EDITION.
 2. ALL CONCRETE FOR STRUCTURES (BEAMS) SHALL BE NORMAL WEIGHT SAND AND GRAVEL AGGREGATE. CONCRETE WITH A MINIMUM 28 DAY COMPRESSIVE STRENGTH OF 3000 PSI. CONCRETE MIX SHALL BE 5 BAGS OF CEMENT PER CUBIC YARD. CONCRETE STRENGTH FOR THE AVERAGE OF ONE PAIR OF STRENGTH TESTS (CYLINDER BEAMS) THAT FALL BELOW THE REQUIRED MINIMUM SHALL BE CAUSE FOR REMOVAL OF PORTIONS OF THE WORK REPRESENTED BY THOSE TESTS.
 3. THERE SHALL BE NO HORIZONTAL JOINTS IN CONCRETE WORK, OTHER THAN THOSE SPECIFICALLY SHOWN, AND ALL CONSTRUCTION JOINTS SHALL BE APPROVED BY ARCHITECT OR ENGINEER. ANY STOP IN CONCRETE PLACEMENT SHALL BE MADE WITH VERTICAL BULKHEADS INCORPORATING A SHEAR KEY AT THE CENTER OF SPANS BUT ONLY UPON THE APPROVAL OF THE STRUCTURAL ENGINEER.
 4. FORMWORK DESIGN IS THE RESPONSIBILITY OF THE CONTRACTOR AND SHALL NOT BE REMOVED UNTIL THE CONCRETE HAS REACHED SUFFICIENT STRENGTH TO CARRY ITS OWN WEIGHT. REMOVAL OF BOTTOM FORMS ON GRADE BEAMS SHALL BE APPROVED BY THE ARCHITECT OR ENGINEER. ADDITIONAL STRENGTH TEST CYLINDERS MAY BE ADVISABLE TO CERTIFY ACCEPTABLE STRENGTH TEST FOR FORM REMOVAL. IN NO CASE SHALL BOTTOM FORMS, IF REQUIRED, BE REMOVED PRIOR TO 7 DAYS AFTER PLACEMENT OF CONCRETE.
 5. UNLESS OTHERWISE NOTED, CONCRETE COVER FOR REINFORCING STEEL SHALL BE:
GRADE BEAM BOTTOMS 3"
GRADE BEAM SIDES 3 1/2"
GRADE BEAM TOPS 1 1/2"
FLOOR SLABS 1 1/2"
 6. ALL PENETRATIONS AND SLEEVED HOLES SHALL BE APPROVED BY THE STRUCTURAL ENGINEER.
 7. CHAMFER ALL EXPOSED CORNERS 3/4" OR AS SHOWN ON DRAWINGS.
- REINFORCING STEEL**
1. ALL REINFORCING STEEL SHALL BE NEW BILLET DOMESTIC DEFORMED BARS CONFORMING TO ASTM A-615, GRADE 60 EXCEPT THAT #3 OR #4 BARS WHICH ARE BARS (STIRRUPS, TIES, OR DOWNELS) MAY BE GRADE 40. GRADE MARKS SHALL BE FLANLY EVIDENT ON ALL GRADE 60 BARS. ALL REINFORCING SHALL BE FREE OF RUST OR MILL SCALE AND SHALL BE STORED ABOVE THE GROUND.
 2. DETAILING AND FABRICATION OF REINFORCING BARS SHALL BE IN ACCORDANCE WITH THE MANUAL OF STANDARD PRACTICE, ACI 318, LATEST EDITION, UNLESS SHOWN OTHERWISE. LAP CONTINUOUS BARS 3/8 BAR DIAMETERS OR A MINIMUM OF 24" AT SPLICES. LAP SPLICE BEAM TOP REINFORCING AT MID-SPAN. BOTTOM REINFORCING OVER PIERS OR SUPPORTS.
 3. REINFORCING BARS MAY NOT BE WELDED OR OTHERWISE HEATED FOR CUTTING WITHOUT APPROVAL OF THE STRUCTURAL ENGINEER.
 4. ALL TOP AND BOTTOM REINFORCEMENT SHALL HAVE 2-#5, 24" x 24" CORNER BARS PLACED WITHIN THEM THAT EXTEND INTO ADJACENT BEAMS AT EXTERIOR CORNERS AND INTERIOR AND EXTERIOR TIES.
 5. ALL STIRRUPS SHALL BE CLOSED STIRRUPS, AND ALL SPAGINGS START AT 8/2 FROM THE CENTERLINE OF THE SUPPORT.
 6. ALL TOP BARS SHALL BE HOOKED AT DISCONTINUOUS ENDS.
 7. PROVIDE NECESSARY TIES AND BAR SUPPORTS AS REQUIRED BY THE MANUAL OF STANDARD PRACTICE, ACI 318, LATEST EDITION. BRICKS, ROCKS OR OTHER MASONRY OR WOOD ARE NOT ACCEPTABLE SUPPORTS. CHAIRS AND BOLSTERS FOR APPLICATION DIRECTLY OVER EARTH POLY SHEETS, OR FELTS SHALL BE EQUIPPED WITH BOTTOM BEARING PLATES.
 8. ALL REINFORCING STEEL SHALL BE FREE FROM ANY BOND REDUCING COATING.
 9. ALL HOOKS REQUIRED FOR REINFORCING SHALL BE 90 DEGREE HOOKS UNLESS OTHERWISE SPECIFIED OR APPROVED. HOOKS SHALL BE PROVIDED AT ALL DISCONTINUOUS ENDS AND FOR ALL BARS AT CANTILEVERS.
 10. CONCRETE COVERAGE FOR THE REINFORCING STEEL SHALL COMPLY WITH ACI 318, LATEST EDITION, ARTICLE 7.7.1, EXCEPT WHERE SPECIFICALLY STATED OTHERWISE.
 11. WHERE OPENINGS IN OR PENETRATIONS THROUGH SLABS FORM INSIDE CORNERS, PROVIDE DIAG. REINFORCING (2-#5 x 4'-0" LONG) ACROSS THE CORNERS. THE REINFORCING SHALL BE PLACED 1 1/2" BELOW THE TOP SURFACE OF THE SLAB.

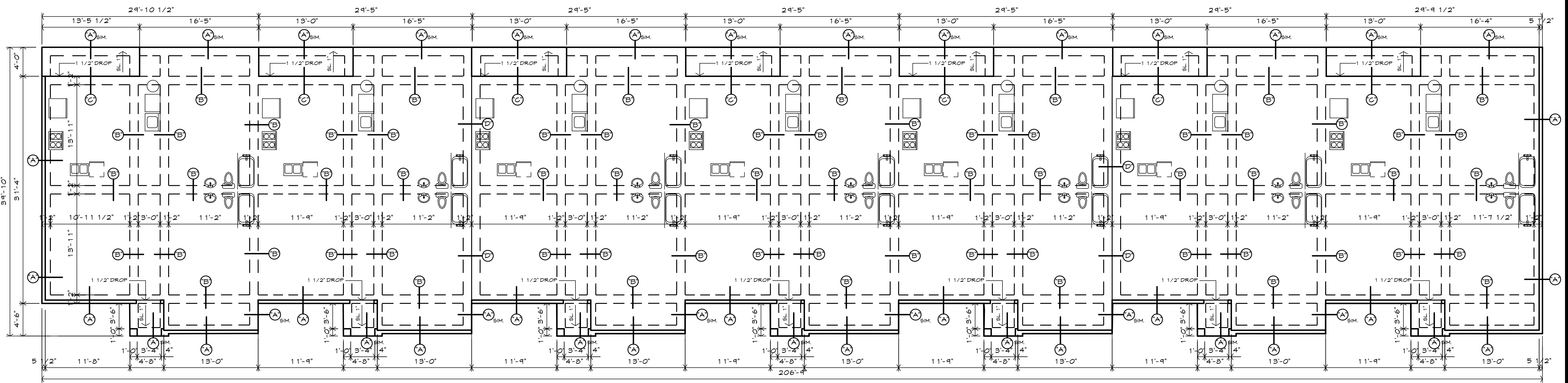

IT IS OF UTMOST IMPORTANCE TO LANDSCAPE THE AREA AROUND THE STRUCTURE SUCH THAT WATER DRAINS RAPIDLY AWAY FROM THE BUILDING AND PAVEMENT. TO ACCOMPLISH THIS THERE SHOULD BE A MINIMUM OF SIX (6) INCHES OF FALL IN THE FIRST TEN (10) FEET AWAY FROM THE STRUCTURE IN ALL DIRECTIONS. PROPER DRAINAGE MAY BE ACHIEVED WHEN THE FINISH FLOOR ELEVATION IS SET A MINIMUM OF TWELVE (12) INCHES ABOVE THE HIGHEST EXISTING GRADE ELEVATION UNDER THE PERIMETER OF THE STRUCTURE. WATER MUST NEVER BE ALLOWED TO COLLECT OR POND NEXT TO THE FOUNDATION.

1 FOUNDATION PLAN BUILDING "A" PHASE 1
1" = 30'-0"

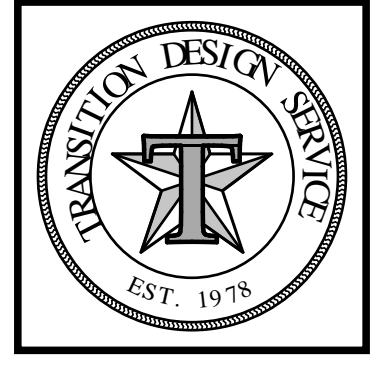

COPPER CREEK CONDOS
COLLEGE STATION TEXAS
Transition Design Service
201 W. Villa Maria Road * Bryan, Texas 77801 * (979) 822-7777

DATE: SEPT. 2014
S 1

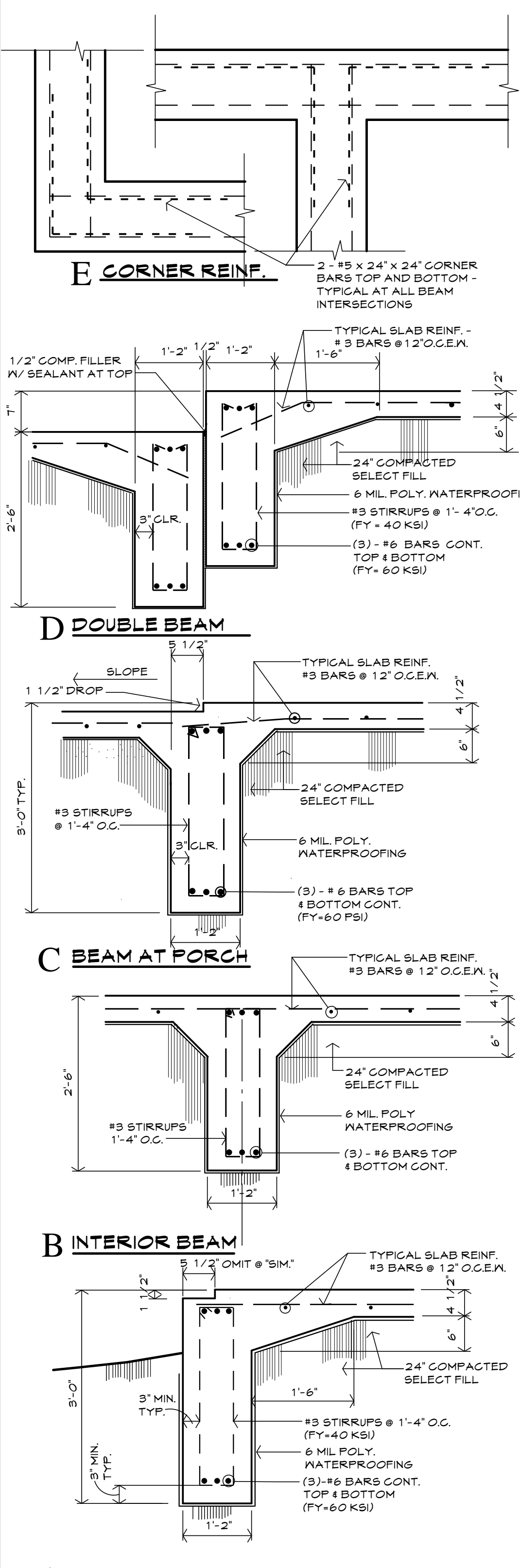

FOUNDATION SPECIFICATIONS

GENERAL

1. THE CONTRACTOR SHALL BE RESPONSIBLE FOR VERIFYING ALL DIMENSIONS PRIOR TO CONSTRUCTION AND FOR CHECKING ARCHITECTURAL VERSUS STRUCTURAL DIMENSIONS. THIS SHALL BE COMPLETED PRIOR TO COMMENCEMENT OF WORK. ANY DISCREPANCIES SHALL BE REPORTED TO THE ARCHITECT FOR CHECKING AND ALLOWANCES MADE FOR MINOR REVISIONS.
2. REFER TO ARCHITECTURAL DRAWINGS FOR FLOOR ELEVATIONS, SLOPED OR DERESSED FLOOR AREAS, FINISHES, BRICK LEDGES, ETC.
3. ALL SOIL UNDER SLAB SHALL BE TREATED WITH A 1% DURBAN TERMITICIDE TREATMENT OR EQUAL BY A CERTIFIED APPLICATOR.
4. 6 MIL. POLYETHYLENE PLASTIC SHEETINGS SHALL BE RUN CONTINUOUSLY UNDER FOUNDATION AS A VAPOR BARRIER.
5. 1/2" X 8" ANCHOR BOLTS SHALL BE PLACED ON 48" CENTERS FOR ALL EXTERIOR WALLS.
6. FOUNDATION SHALL COMPLY WITH ALL CITY OF BRYAN REQUIREMENTS.

EXCAVATION & FILL

1. BOTTOMS AND SIDES OF EXCAVATIONS SHALL BE CLEANED BEFORE CONCRETE IS PLACED. ALL WATER OR OTHER DELETERIOUS MATERIALS AND LOOSE SOIL SHALL BE REMOVED FROM THE EXCAVATIONS PRIOR TO CONCRETE PLACEMENT. CONCRETE SHALL BE PLACED IN ALL FOOTINGS ON THE SAME DAY IN WHICH THEY ARE EXCAVATED AND MEASURES TO PREVENT EXCESSIVE DRYING OR MOISTENING OF THE EXCAVATION DURING THE TIMES OPENED SHALL BE TAKEN BY THE CONTRACTOR.
2. PROVIDE 24" OF SELECT FILL. FILL MATERIAL SHALL BE FREE OF ANY ORGANICS, CLAY BALLS, OR OTHER DELETERIOUS MATERIALS. ONLY FILL WITH A FINER THAN OR EQUAL TO 15 WILL BE ACCEPTABLE WITH SPECIFIED COMPACTION (A.S.T.M. D698).

CAST-IN-PLACE CONCRETE

1. ALL CONCRETE WORK SHALL BE IN ACCORDANCE WITH THE BUILDING CODE REQUIREMENTS FOR REINFORCED CONCRETE, ACI 318, LATEST EDITION.
2. ALL CONCRETE FOR STRUCTURES (BEAMS) SHALL BE NORMAL WEIGHT, SAND AND GRAVEL AGGREGATE. CONCRETE WITH A MINIMUM 28 DAY COMPRESSIVE STRENGTH OF 3000 PSI. CONCRETE MIX SHALL BE 5 BAGS OF CEMENT PER CUBIC YARD. CONCRETE STRENGTH FOR THE AVERAGE OF ONE PAIR OF STRENGTH TESTS (CYLINDER BREAKS) THAT FALL BELOW THE REQUIRED MINIMUM SHALL BE CAUSE FOR REMOVAL OF PORTIONS OF THE WORK REPRESENTED BY THOSE TESTS.
3. THERE SHALL BE NO HORIZONTAL JOINTS IN CONCRETE WORK OTHER THAN THOSE SPECIFICALLY SHOWN, AND ALL CONSTRUCTION JOINTS SHALL BE APPROVED BY THE ARCHITECT OR ENGINEER. ANY STOP IN CONCRETE PLACEMENT SHALL BE MADE WITH VERTICAL BULKHEADS INCORPORATING A SHEAR KEY AT THE CENTER OF SPANS BUT ONLY UPON THE APPROVAL OF THE STRUCTURAL ENGINEER.
4. FORMWORK DESIGN IS THE RESPONSIBILITY OF THE CONTRACTOR AND SHALL NOT BE REMOVED UNTIL THE CONCRETE HAS REACHED SUFFICIENT STRENGTH TO CARRY ITS OWN WEIGHT. REMOVAL OF BOTTOM FORMS ON GRADE BEAMS SHALL BE APPROVED BY THE ARCHITECT OR ENGINEER. ADDITIONAL STRENGTH TEST BY JUNDERS MAY BE ADVISABLE TO CERTIFY ACCEPTABLE STRENGTH TEST FOR FORM REMOVAL. IN NO CASE SHALL BOTTOM FORMS, IF REQUIRED, BE REMOVED PRIOR TO 1 DAY'S AFTER PLACEMENT OF CONCRETE.
5. UNLESS OTHERWISE NOTED, CONCRETE COVER FOR REINFORCING STEEL SHALL BE:
GRADE BEAM BOTTOMS 3"
GRADE BEAM SIDES 3"
GRADE BEAM TOPS 1 1/2"
FLOOR SLABS 1 1/2"
6. ALL PENETRATIONS AND SLEEVED HOLES SHALL BE APPROVED BY THE STRUCTURAL ENGINEER.
7. CHAMFER ALL EXPOSED CORNERS 3/4", OR AS SHOWN ON DRAWINGS.

REINFORCING STEEL

1. ALL REINFORCING STEEL SHALL BE NEW BILLET DOMESTIC DEFORMED BARS CONFORMING TO ASTM A-615, GRADE 60, EXCEPT THAT #2 OR #4 BARS WHICH ARE BENT (STIRRUPS, TIES, OR DOPELS) MAY BE GRADE 40. GRADE MARKS SHALL BE PLAINLY EVIDENT ON ALL GRADE 60 BARS. ALL REINFORCING SHALL BE FREE OF RUST OR MILL SCALE AND SHALL BE STORED ABOVE THE GROUND.
2. DETAILING AND FABRICATION OF REINFORCING BARS SHALL BE IN ACCORDANCE WITH THE MANUAL OF STANDARD PRACTICE ACI 318, LATEST EDITION, UNLESS SHOWN OTHERWISE. LAP CONTINUOUS BARS 36 BAR DIAMETERS OR A MINIMUM OF 24" AT SPLICES. LAP SPLICE BEAM TOP REINFORCING AT MID-SPAN BOTTOM REINFORCING OVER PIERS OR SUPPORTS.
3. REINFORCING BARS MAY NOT BE WELDED OR OTHERWISE HEATED FOR CUTTING WITHOUT APPROVAL OF THE STRUCTURAL ENGINEER.
4. ALL TOP AND BOTTOM REINFORCEMENT SHALL HAVE 2-#5, 24" X 24" CORNER BARS PLACED WITHIN THEM THAT EXTEND INTO ADJACENT BEAMS AT EXTERIOR CORNERS AND INTERIOR AND EXTERIOR TEES.
5. ALL STIRRUPS SHALL BE CLOSED STIRRUPS AND ALL SPACINGS START AT 5/2 FROM THE CENTERLINE OF THE SUPPORT.
6. ALL TOP BARS SHALL BE HOOKED AT DISCONTINUOUS ENDS.
7. PROVIDE NECESSARY TIES AND BAR SUPPORTS AS REQUIRED BY THE MANUAL OF STANDARD PRACTICE, ACI 318, LATEST EDITION. BRICKS, ROCKS OR OTHER MASONRY OR FLOOR ARE NOT ACCEPTABLE SUPPORTS. CHAIRS AND BOLSTERS FOR APPLICATION DIRECTLY OVER EARTH, POLY SHEETS, OR FELTS SHALL BE EQUIPPED WITH BOTTOM BEARING PLATES.
8. ALL REINFORCING STEEL SHALL BE FREE FROM ANY BOND REDUCING COATINGS.
9. ALL HOOKS REQUIRED FOR REINFORCING SHALL BE 90 DEGREE HOOKS, UNLESS OTHERWISE SPECIFIED OR APPROVED. HOOKS SHALL BE PROVIDED AT ALL DISCONTINUOUS ENDS AND FOR ALL BARS AT CANTILEVERS.
10. CONCRETE COVERAGE FOR THE REINFORCING STEEL SHALL COMPLY WITH ACI 318, LATEST EDITION ARTICLE 7.1.1, EXCEPT WHERE SPECIFICALLY STATED OTHERWISE.
11. WHERE OPENINGS IN OR PENETRATIONS THROUGH SLABS FORM INSIDE CORNERS, PROVIDE DIAG. REINFORCING (2-#5 X 4'-0" LONG) ACROSS THE CORNERS. THIS REINFORCING SHALL BE PLACED 1 1/2" BELOW THE TOP SURFACE OF THE SLAB.

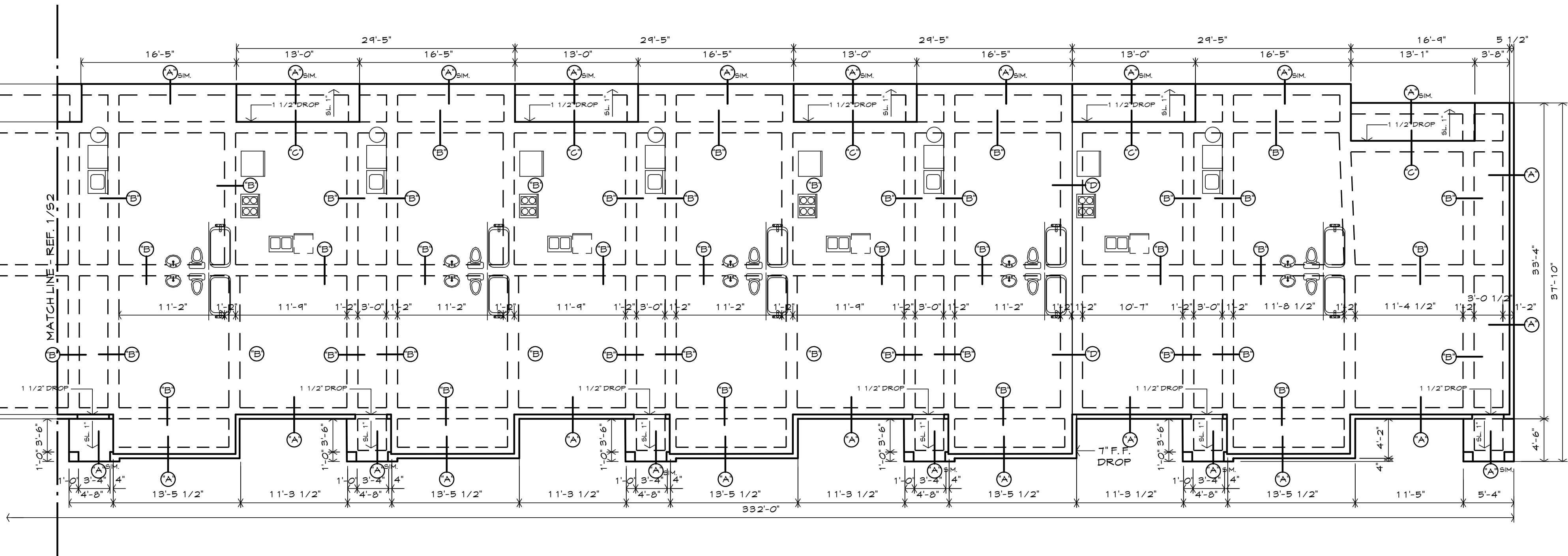

3 FOUNDATION DETAILS
NOTE: GRADE BEAMS TO EXTEND MIN. 1'-0" INTO UNDISTURBED SOIL
3/4" = 1'-0"

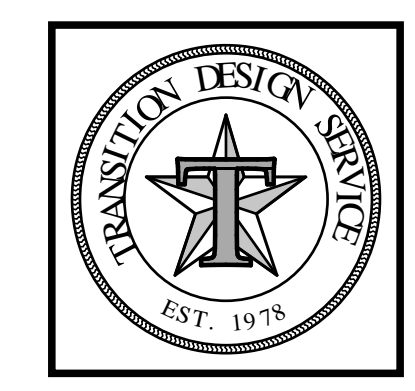
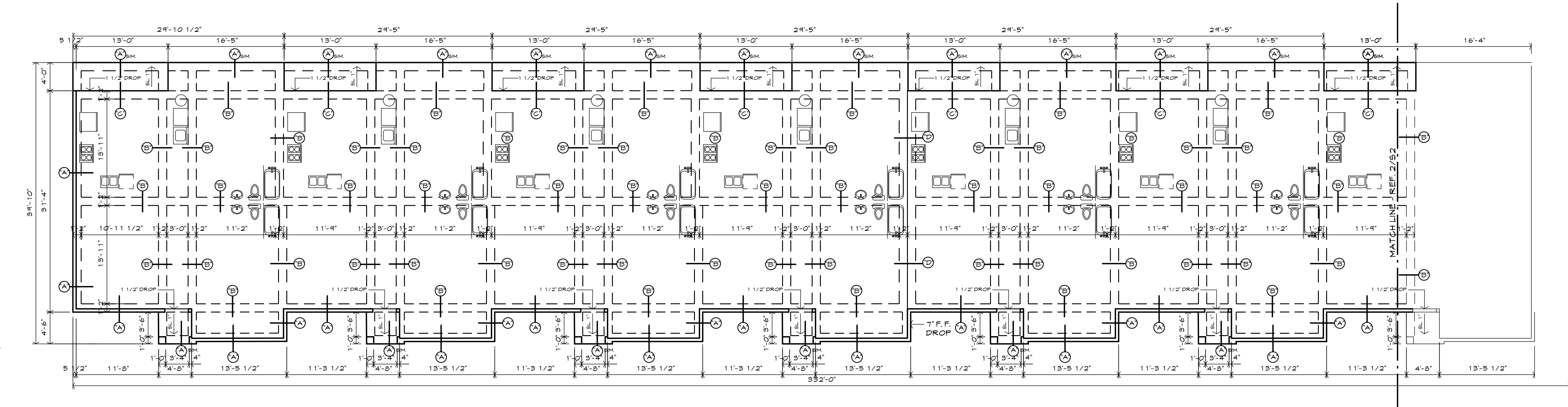

COPPER CREEK CONDOS
COLLEGE STATION TEXAS
Transition Design Service
201 W. Villa Maria Road * Bryan, Texas 77801 * (979) 822-7777

DATE: SEPT. 2014
S2

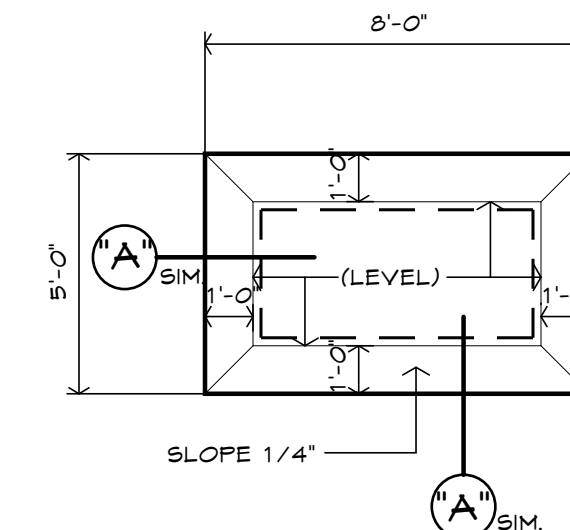

3 FOUND. PLAN MAILBOX
 1/4" = 1'-0"

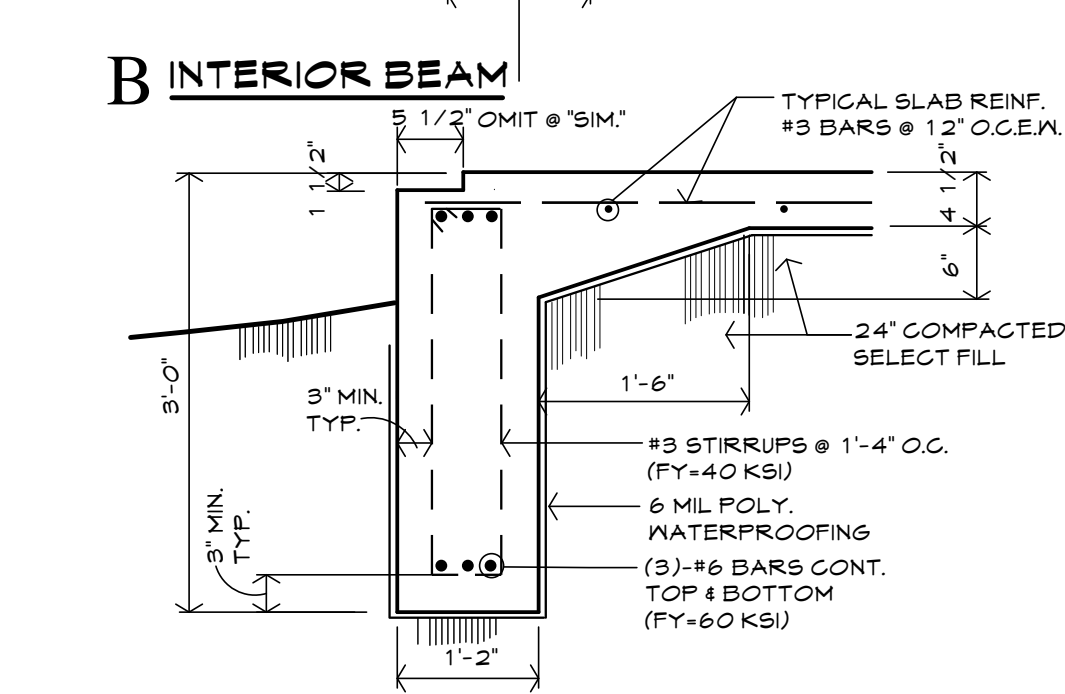
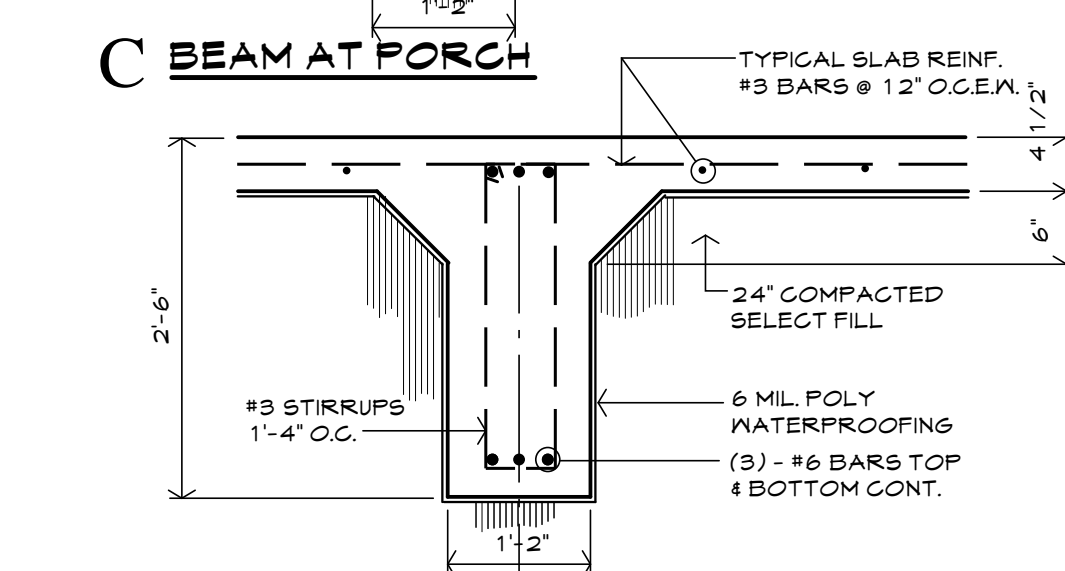
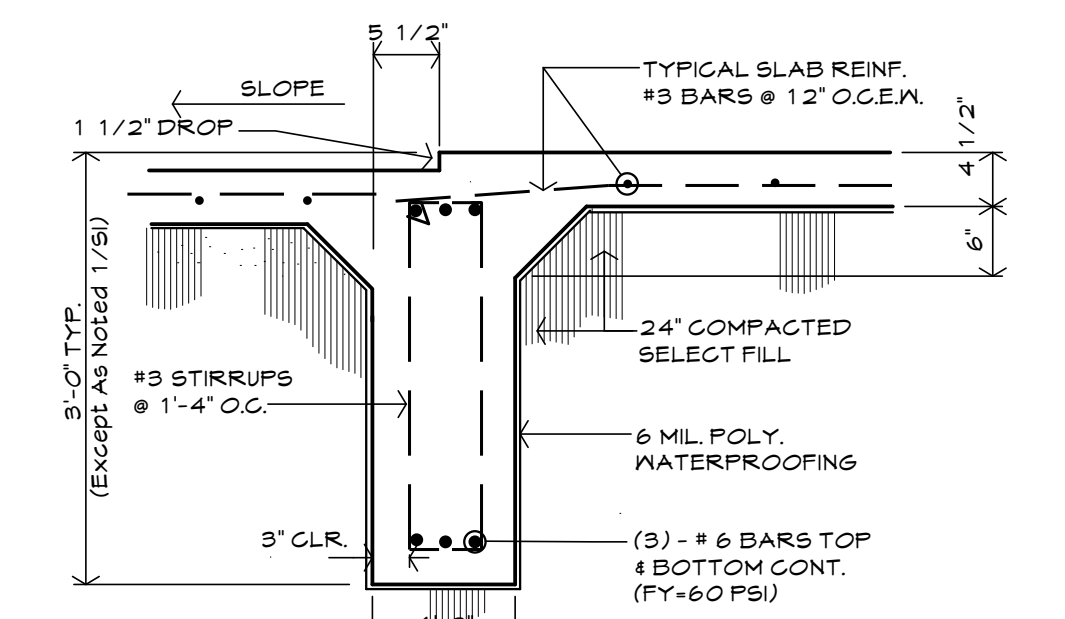
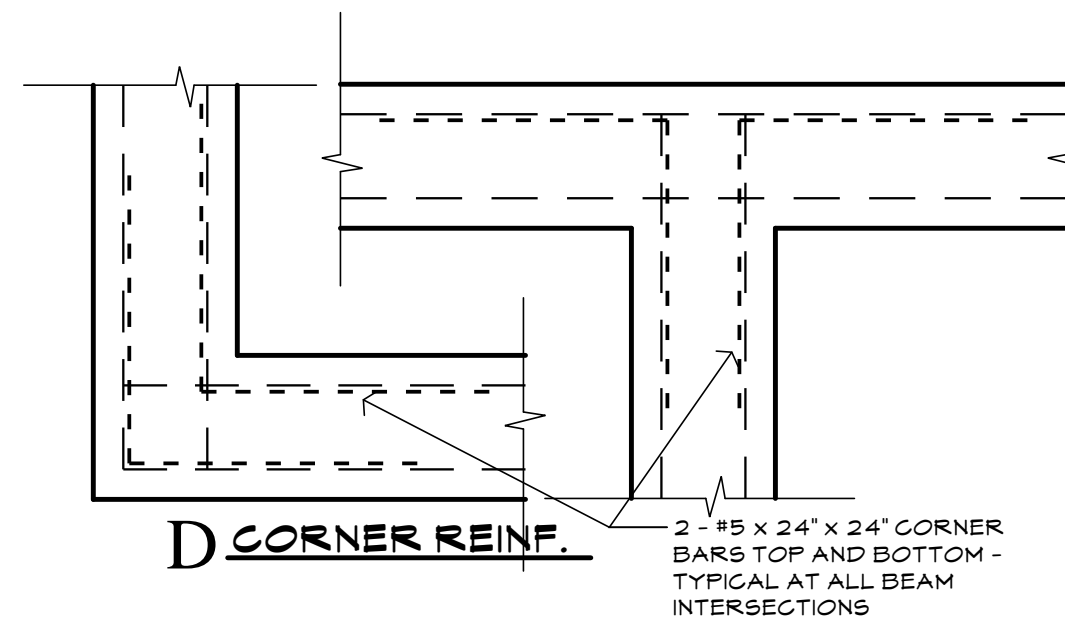

4 FOUNDATION DETAILS
 3/4" = 1'-0"

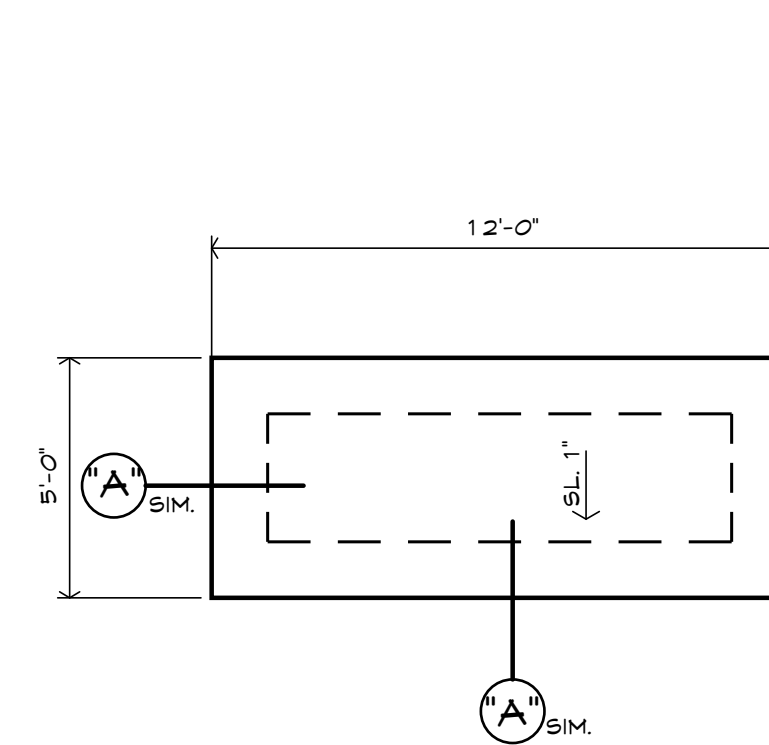

2 FOUND. PLAN BUS STOP
 1/4" = 1'-0"

FOUNDATION SPECIFICATIONS

- GENERAL**
1. THE CONTRACTOR SHALL BE RESPONSIBLE FOR VERIFYING ALL DIMENSIONS PRIOR TO CONSTRUCTION AND FOR CHECKING ARCHITECTURAL VERSUS STRUCTURAL DIMENSIONS. THIS SHALL BE COMPLETED PRIOR TO COMMENCEMENT OF THE WORK. ANY DISCREPANCIES SHALL BE REPORTED TO THE ARCHITECT FOR CHECKING AND ALLOWANCES MADE FOR MINOR REVISIONS.
 2. REFER TO ARCHITECTURAL DRAWINGS FOR FLOOR ELEVATIONS, SLOPED OR DEPRESSED FLOOR AREAS, FINISHES, BRICK LEDGES, ETC.
 3. ALL SOIL UNDER SLAB SHALL BE TREATED WITH A 1% DURBAN TERMITIC TREATMENT, OR EQUAL, BY A CERTIFIED APPLICATOR.
 4. 6 MIL. POLYETHYLENE PLASTIC SHEETINGS SHALL BE RUN CONTINUOUSLY UNDER FOUNDATION AS A VAPOR BARRIER.
 5. 1/2" x 8" ANCHOR BOLTS SHALL BE PLACED ON 48" CENTERS FOR ALL EXTERIOR WALLS.
 6. FOUNDATION SHALL COMPLY WITH ALL CITY OF BRYAN REQUIREMENTS.
- EXCAVATION/LEILL**
1. BOTTOMS AND SIDES OF EXCAVATIONS SHALL BE CLEANED BEFORE CONCRETE IS PLACED. ALL WATER OR OTHER DELETERIOUS MATERIALS AND LOOSE SOIL SHALL BE REMOVED FROM THE EXCAVATIONS PRIOR TO CONCRETE PLACEMENT. CONCRETE SHALL BE PLACED IN ALL FOOTINGS ON THE SAME DAY IN WHICH THEY ARE EXCAVATED AND MEASURES TO PREVENT EXCESSIVE DRYING OR MOISTENING OF THE EXCAVATION DURING THE TIMES OPENED SHALL BE TAKEN BY THE CONTRACTOR.
 2. PROVIDE 24" OF SELECT FILL. FILL MATERIAL SHALL BE FREE OF ANY ORGANICS, CLAY BALLS, OR OTHER DELETERIOUS MATERIALS. ONLY FILL WITH A FILLER THAN OR EQUAL TO 15 WILL BE ACCEPTABLE WITH SPECIFIED COMPACTION (ASTM D698).
- CAST-IN-PLACE CONCRETE**
1. ALL CONCRETE WORK SHALL BE IN ACCORDANCE WITH THE BUILDING CODE REQUIREMENTS FOR REINFORCED CONCRETE, ACI 318, LATEST EDITION.
 2. ALL CONCRETE FOR STRUCTURES (BEAMS) SHALL BE NORMAL WEIGHT SAND AND GRAVEL AGGREGATE. CONCRETE WITH A MINIMUM 28 DAY COMPRESSIVE STRENGTH OF 3000 PSI. CONCRETE MIX SHALL BE 9 BAGS OF CEMENT PER CUBIC YARD. CONCRETE STRENGTHS FOR THE AVERAGE OF ONE PAIR OF STRENGTH TESTS (CYLINDER BREAKS) THAT FALL BELOW THE REQUIRED MINIMUM SHALL BE CAUSE FOR REMOVAL OF PORTIONS OF THE WORK REPRESENTED BY THOSE TESTS.
 3. THERE SHALL BE NO HORIZONTAL JOINTS IN CONCRETE WORK, OTHER THAN THOSE SPECIFICALLY SHOWN, AND ALL CONSTRUCTION JOINTS SHALL BE APPROVED BY THE ARCHITECT OR ENGINEER. ANY STOP IN CONCRETE PLACEMENT SHALL BE MADE WITH VERTICAL BULKHEADS INCORPORATING A SHEAR KEY AT THE CENTER OF SPANS BUT UPON THE APPROVAL OF THE STRUCTURAL ENGINEER.
 4. FORMWORK DESIGN IS THE RESPONSIBILITY OF THE CONTRACTOR AND SHALL NOT BE REMOVED UNTIL THE CONCRETE HAS REACHED SUFFICIENT STRENGTH TO CARRY ITS OWN WEIGHT. REMOVAL OF BOTTOM FORMS ON GRADE BEAMS SHALL BE APPROVED BY THE ARCHITECT OR ENGINEER. ADDITIONAL STRENGTH TEST BY INDICES MAY BE ADVISABLE TO CERTIFY ACCEPTABLE STRENGTH TEST FOR FORM REMOVAL. IN NO CASE SHALL BOTTOM FORMS, IF REQUIRED, BE REMOVED PRIOR TO 7 DAYS AFTER PLACEMENT OF CONCRETE.
 5. UNLESS OTHERWISE NOTED, CONCRETE COVER FOR REINFORCING STEEL SHALL BE:
 GRADE BEAM BOTTOMS 3"
 GRADE BEAM SIDES 3"
 GRADE BEAM TOPS 1 1/2"
 FLOOR SLABS 1 1/2"
 6. ALL PENETRATIONS AND SLEEVED HOLES SHALL BE APPROVED BY THE STRUCTURAL ENGINEER.
 7. CHAMFER ALL EXPOSED CORNERS 3/4", OR AS SHOWN ON DRAWINGS.
- REINFORCING STEEL**
1. ALL REINFORCING STEEL SHALL BE NEW BILLET DOMESTIC DEFORMED BARS CONFORMING TO ASTM A615, GRADE 60 EXCEPT THAT #3 OR #4 BARS MAY BE BENT, (STIRRUPS, TIES, OR DOBELS) MAY BE GRADE 40. GRADE MARKS SHALL BE PLAINLY EVIDENT ON ALL GRADE 60 BARS. ALL REINFORCING SHALL BE FREE OF RUST OR MILL SCALE AND SHALL BE STORED ABOVE THE GROUND.
 2. DETAILING AND FABRICATION OF REINFORCING BARS SHALL BE IN ACCORDANCE WITH THE MANUAL OF STANDARD PRACTICE, ACI 315, LATEST EDITION, UNLESS SHOWN OTHERWISE. LAP CONTINUOUS BARS 36 BAR DIAMETERS, OR A MINIMUM OF 24" AT SPLICES. LAP SPlice BEAM TOP REINFORCING AT MID-SPAN, BOTTOM REINFORCING OVER PIERS OR SUPPORTS.
 3. REINFORCING BARS MAY NOT BE WELDED OR OTHERWISE HEATED FOR CUTTING WITHOUT APPROVAL OF THE STRUCTURAL ENGINEER.
 4. ALL TOP AND BOTTOM REINFORCEMENT SHALL HAVE 2-#5, 24" x 24" CORNER BARS PLACED WITHIN THEM THAT EXTEND INTO ADJACENT BEAMS AT EXTERIOR CORNERS AND INTERIOR AND EXTERIOR TIES.
 5. ALL STIRRUPS SHALL BE CLOSED STIRRUPS, AND ALL SPACINGS START AT 5/2 FROM THE CENTERLINE OF THE SUPPORT.
 6. ALL TOP BARS SHALL BE HOOKED AT DISCONTINUOUS ENDS.
 7. PROVIDE NECESSARY TIES AND BAR SUPPORTS AS REQUIRED BY THE MANUAL OF STANDARD PRACTICE, ACI 315, LATEST EDITION. BRICKS, ROCKS OR OTHER MASONRY OR WOOD ARE NOT ACCEPTABLE SUPPORTS. CHAIRS AND BOLSTERS FOR APPLICATION DIRECTLY OVER EARTH, POLY SHEETS, OR FELTS SHALL BE EQUIPPED WITH BOTTOM BEARING PLATES.
 8. ALL REINFORCING STEEL SHALL BE FREE FROM ANY BOND REDUCING COATINGS.
 9. ALL HOOKS REQUIRED FOR REINFORCING SHALL BE 90 DEGREE HOOKS UNLESS OTHERWISE SPECIFIED OR APPROVED. HOOKS SHALL BE PROVIDED AT ALL DISCONTINUOUS ENDS AND FOR ALL BARS AT CANTILEVERS.
 10. CONCRETE COVERAGE FOR THE REINFORCING STEEL SHALL COMPLY WITH ACI 318, LATEST EDITION ARTICLE 1.1.1, EXCEPT WHERE SPECIFICALLY STATED OTHERWISE.
 11. WHERE OPENINGS IN OR PENETRATIONS THROUGH SLABS FORM INSIDE CORNERS, PROVIDE DIAG. REINFORCING (2-#5 x 4'-0" LONG) ACROSS THE CORNERS. THIS REINFORCING SHALL BE PLACED 1 1/2" BELOW THE TOP SURFACE OF THE SLAB.

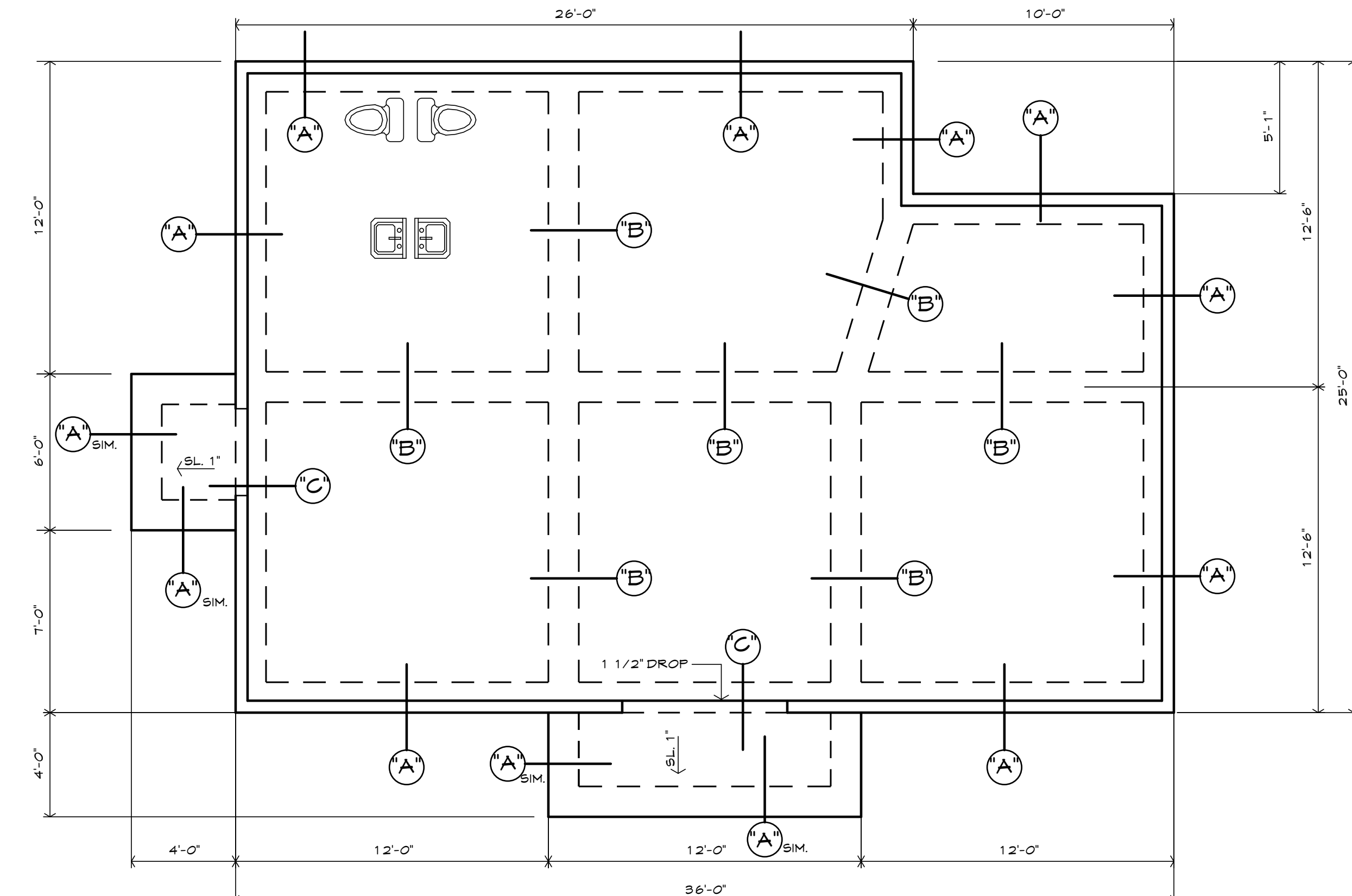

1 FOUNDATION PLAN CLUB HOUSE PHASE 1
 1/4" = 1'-0"

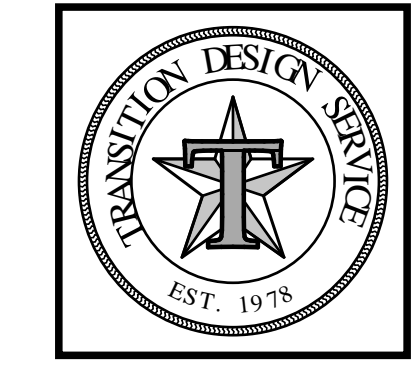

COPPER CREEK CONDOS
 COLLEGE STATION TEXAS
Transition Design Service
 201 W. Villa Maria Road * Bryan, Texas 77801 * (979) 822-7777

DATE: SEPT. 2014
53

EXHIBIT "B"
TO
DECLARATION OF COPPER CREEK CONDOS
PERCENT INTEREST CHART

<u>Bldg. No.</u>	<u>Unit No. On Plans</u>	<u>Percent Interest</u>
A	302	5.2631%
A	303	5.2631%
A	304	5.2631%
A	305	5.2631%
A	306	5.2631%
A	307	5.2631%
A	308	5.2631%
E	343	5.2631%
E	344	5.2631%
E	345	5.2631%
E	346	5.2631%
E	347	5.2631%
E	348	5.2631%
E	349	5.2631%
E	350	5.2631%
E	351	5.2631%
E	352	5.2631%
E	353	5.2631%
E	354	5.2631%

EXHIBIT "C"
TO
DECLARATION OF COPPER CREEK CONDOS
ENCUMBRANCES UPON TITLE

The Condominium is subject to:

- (a) Terms, conditions and restrictions of the Declaration, the By-Laws, the Plans and the Rules and Regulations, if any, as each may be amended from time to time.
- (b) General utility easements to the City of College Station and any other public utilities.
- (c) Unrecorded easements, discrepancies or conflicts in boundary lines, shortages in area encroachments which an accurate and complete survey would disclose, including any easements and encroachments as shown on the Plat and Plans.
- (d) Restrictions recorded in Volume 800, Page 173, Volume 810, Page 331 and Volume 6431, Page 215, Official Records of Brazos County, Texas.
- (e) Building lines, and any and all easements as reserved on plat recorded in Volume 7627, Page 19, Official Records of Brazos County, Texas; as modified in Ordinance recorded in Volume 11191, Page 22, Official Records of Brazos County, Texas.
- (f) Utility Easement executed by Kenneth W. Schick, Trustee to City of College Station, Texas, dated March 22, 1985, recorded in Volume 776, Page 138, Official Records of Brazos County, Texas.
- (g) Easement Agreement executed by 1127 Joint Venture to Southland Corporation, dated July 24, 1985, recorded in Volume 827, Page 742, Official Records of Brazos County, Texas.
- (h) Easement Agreement executed by 1127 Joint Venture to Jay P. Kraak, dated March 20, 1986, recorded in Volume 870, Page 126, Official Records of Brazos County, Texas.
- (i) Public Utility Easement executed by Four Ags Investments, L.P. to City of College Station, Texas, dated October 30, 2009, recorded in Volume 9388, Page 252, Official Records of Brazos County, Texas.

- (j) Temporary Blanket Utility Easement executed by Four Ags Investments, L.P. to City of College Station, Texas, dated October 30, 2009, recorded in Volume 9388, Page 267, Official Records of Brazos County, Texas.
- (k) Interest in and to all coal, lignite, oil, gas and other minerals, and all rights incident thereto, contained in instrument dated March 22, 1985, recorded on March 22, 1985, in Volume 775, Page 277, Official Records of Brazos County, Texas.
- (l) Interest in and to all coal, lignite, oil, gas and other minerals, and all rights incident thereto, contained in instrument dated February 25, 2005, recorded on March 4, 2005, in Volume 6548, Page 176, Official Records of Brazos County, Texas.
- (m) Interest in and to all coal, lignite, oil, gas and other minerals, and all rights incident thereto, contained in instrument dated August 5, 2010, recorded on August 6, 2010, in Volume 9766, Page 42, Official Records of Brazos County, Texas.
- (n) Lease for coal, lignite, oil, gas or other minerals, together with rights incident thereto, dated March 4, 1983, by and between Mrs. Linda McDonald, as Lessor, and Jordan Engineering, Inc., as Lessee, recorded on March 30, 1983 in Volume 83, Page 116, of the Oil and Gas Lease Records of Brazos County, Texas.
- (o) Lease for coal, lignite, oil, gas or other minerals, together with rights incident thereto, dated March 4, 1983, by and between Ida Mae Walker, as Lessor, and Jordan Engineering, Inc., as Lessee, recorded on March 30, 1983 in Volume 83, Page 118, of the Oil and Gas Lease Records of Brazos County, Texas.
- (p) Lease for coal, lignite, oil, gas or other minerals, together with rights incident thereto, dated March 4, 1983, by and between Evelyn Ann Walker, as Lessor, and Jordan Engineering, Inc., as Lessee, recorded on March 30, 1983 in Volume 83, Page 120, of the Oil and Gas Lease Records of Brazos County, Texas.
- (q) Lease for coal, lignite, oil, gas or other minerals, together with rights incident thereto, dated March 4, 1983, by and between Candiss Faye Graves, as Lessor, and Jordan Engineering, Inc., as Lessee, recorded on March 30, 1983 in Volume 83, Page 122, of the Oil and Gas Lease Records of Brazos County, Texas.
- (r) Documents entitled Waiver of Surface Use executed by Jordan Engineering, Inc., dated November 26, 1984, recorded in Volume 750, Pages 837, 840, 843 and 846, Official Records of Brazos County, Texas.
- (s) Easements, or claims of easements, which are not recorded in the public records.

EXHIBIT "D"
TO
DECLARATION OF COPPER CREEK CONDOS

ARTICLES OF FORMATION
OF
COPPER CREEK CONDOS HOA, INC.

<p>Form 202 (Revised 05/11)</p> <p>Submit in duplicate to: Secretary of State P.O. Box 13697 Austin, TX 78711-3697 512 463-5555 FAX: 512/463-5709 Filing Fee: \$25</p>	<p style="text-align: right;">This space reserved for office use.</p> <div style="text-align: center;">  <p>Certificate of Formation Nonprofit Corporation</p> </div> <div style="text-align: right;"> <p>FILED In the Office of the Secretary of State of Texas</p> <p>FEB 17 2015</p> <p>Corporations Section</p> </div>
--	--

Article 1 – Entity Name and Type

The filing entity being formed is a nonprofit corporation. The name of the entity is:

Copper Creek Condos HOA

Article 2 – Registered Agent and Registered Office

(See instructions. Select and complete either A or B and complete C.)

A. The initial registered agent is an organization (cannot be entity named above) by the name of:

OR

B. The initial registered agent is an individual resident of the state whose name is set forth below:

Alton		Ofczarzak	
<i>First Name</i>	<i>M.I.</i>	<i>Last Name</i>	<i>Suffix</i>

C. The business address of the registered agent and the registered office address is:

4060 State Highway 6 South	College Station	TX	77845
<i>Street Address</i>	<i>City</i>	<i>State</i>	<i>Zip Code</i>

Article 3 – Management

The management of the affairs of the corporation is vested in the board of directors. The number of directors constituting the initial board of directors and the names and addresses of the persons who are to serve as directors until the first annual meeting of members or until their successors are elected and qualified are as follows:

A minimum of three directors is required.

Director 1				
Alton		Ofczarzak		
<i>First Name</i>	<i>M.I.</i>	<i>Last Name</i>	<i>State</i>	<i>Suffix</i>
4060 State Highway 6 South	College Station	TX	77845	USA
<i>Street or Mailing Address</i>	<i>City</i>	<i>State</i>	<i>Zip Code</i>	<i>Country</i>

Director 2				
Vicki		Friedberg		
<i>First Name</i>	<i>M.I.</i>	<i>Last Name</i>	<i>Suffix</i>	
4060 State Highway 6 South	College Station	TX	77845	USA
<i>Street or Mailing Address</i>	<i>City</i>	<i>State</i>	<i>Zip Code</i>	<i>Country</i>

Director 3				
Monica		Longoria		
<i>First Name</i>	<i>M.I.</i>	<i>Last Name</i>	<i>Suffix</i>	
4060 State Highway 6 South	College Station	TX	77845	USA
<i>Street or Mailing Address</i>	<i>City</i>	<i>State</i>	<i>Zip Code</i>	<i>Country</i>

OR

The management of the affairs of the corporation is to be vested in the nonprofit corporation's members.

Article 4 – Membership

(See instructions. Do not select statement B if the corporation is to be managed by its members.)

- A. The nonprofit corporation shall have members.
- B. The nonprofit corporation will have no members.

Article 5 – Purpose

(See instructions. This form does not contain language needed to obtain a tax-exempt status on the state or federal level.)

The nonprofit corporation is organized for the following purpose or purposes:

This nonprofit corporation is formed for any lawful purpose or purposes not expressly prohibited under Chapters 2 or 22 of the Texas Business Organizations Code, including any purpose described by Section 2.002 of the Code

The following text area may be used to include any additional language or provisions that may be needed to obtain tax-exempt status.

Please see the attached letter of consent from Mr. Angel Cacho-Negrete in which he authorizes the usage of "Copper Creek Condos HOA" as required per his being the principal of "Copper Creek Condos, LLC." Thank you.

Supplemental Provisions/Information
(See instructions.)

Text Area: [The attached addendum, if any, is incorporated herein by reference.]

Organizer

The name and address of the organizer:

Joe R. Patranella

Name

1450 Copperfield Pkwy., Ste. 300

College Station

TX

77845-5785

Street or Mailing Address

City

State

Zip Code

Effectiveness of Filing (Select either A, B, or C.)

- A. This document becomes effective when the document is filed by the secretary of state.
- B. This document becomes effective at a later date, which is not more than ninety (90) days from the date of signing. The delayed effective date is: _____
- C. This document takes effect upon the occurrence of a future event or fact, other than the passage of time. The 90th day after the date of signing is: _____

The following event or fact will cause the document to take effect in the manner described below:

Execution

The undersigned affirms that the person designated as registered agent has consented to the appointment. The undersigned signs this document subject to the penalties imposed by law for the submission of a materially false or fraudulent instrument and certifies under penalty of perjury that the undersigned is authorized to execute the filing instrument.

Date: 2/16/15



Signature of organizer

Joe R. Patranella

Printed or typed name of organizer

**Angel Cacho-Negrete
Copper Creek Condos, LLC
3010 E. Villa Maria
Bryan, Texas 77803**

February 12, 2015

Texas Secretary of State
P.O. Box 13697
Austin, Texas 78711

Re: Letter of Consent regarding Copper Creek Condos HOA

To Whom It May Concern:

My name is Angel Cacho-Negrete and I am the principal and registered agent for Copper Creek Condos, LLC. I hereby authorize and give consent to Alton Ofczarzak to use the name "Copper Creek Condos HOA" to form a non-profit corporation under the State of Texas.

If you need any further information, please do not hesitate to contact me at the information listed above. Thank you for your time and assistance in this matter.

Very Truly Yours,

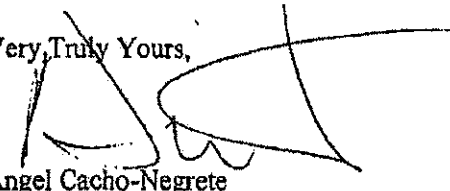

Angel Cacho-Negrete

EXHIBIT "E"
TO
DECLARATION OF COPPER CREEK CONDOS, A CONDOMINIUM

BY-LAWS
OF
COPPER CREEK CONDOS HOA, INC.

**BY-LAWS OF
COPPER CREEK CONDOS HOA, INC.**

ARTICLE I.

Name, Membership, Applicability and Definitions

- 1.1 Name. The name of the Association shall be COPPER CREEK CONDOS HOA, INC. (hereinafter sometimes referred to as the "Association").
- 1.2 Membership. All Unit Owners, as that term is defined in the Declaration of Copper Creek Condos, A Condominium, shall be members of the Association and the terms of the above referenced Declaration which pertain to membership are specifically incorporated herein by reference.
- 1.3 Definitions. The words used in these By-Laws shall have the same meaning as set forth in said Declaration, unless the context shall prohibit.

ARTICLE II.

Association: Meetings, Quorum, Voting, Proxies

- 2.1 Place of Meetings. Meetings of the Association shall be held at the principal office of the Association or at such other suitable place convenient to the members as may be designated by the Board either in COPPER CREEK CONDOS or as convenient thereto as possible and practical.
- 2.2 Annual Meeting. An annual meeting of the Unit Owners shall be held at 7:00 o'clock p.m. on the third Tuesday in March of each year, provided, however, that if the third Monday in March is a legal holiday, then the meeting shall be held at the same time on the second business day following the legal holiday, for the purpose of electing members of the Board and for the transaction of such other business as may be properly brought before the meeting.
- 2.3 Substitute Annual Meetings. If the annual meeting shall not be held on the day designated by the By-Laws, a substitute annual meeting may be called in accordance the provisions of Section 2.4 of this Article. A meeting so called shall be designated and treated for all purposes as the annual meeting.
- 2.4 Special Meetings. Special meetings of the Unit Owners may be called at any time by the Board, the chairman or upon the written request of the Unit Owners owning at least fifty percent (50%) in common interest in the Common Elements other than those Units held by the Declarant.

- 2.5 Notice of Meetings. Written or printed notice stating the place, day and hour of any meeting shall be delivered or mailed not less than ten (10) days nor more than fifty (50) days prior to the date thereof, either personally or by postage prepaid mail, at the direction of the Board, the chairman or Unit Owners calling the meeting, to each person entitled to vote at such meeting, and, to all Eligible Mortgage Holders so requesting under the provisions of Section 13.9 of the Declaration, who may request representative to attend the meeting of Unit Owners.

The notice of any meeting must state the time and place of the meeting and the items on the agenda, including the general nature of any proposed amendment to the Declaration or these By-Laws, and budget changes, and any proposal to remove Board members or officers.

When a meeting is adjourned for less than thirty (30) days in any one adjournment, it not necessary to give any notice of the adjourned meeting, other than by announcement at the meeting at which the adjournment is effective.

- 2.6 Quorum. The presence in person or by proxy at any meeting of the Voting members (as defined in Section 2.7 of this Article) having five percent (5%) or more of the total votes shall constitute a quorum. If there is no quorum at the opening of the meeting of Unit Owners, such meeting may be adjourned from time to time by the vote of a majority of the Voting Members present, either in person or by proxy; and at any adjourned meeting at which a quorum is present, any business may be transacted which might have been transacted at the original meeting.

The Voting Members at a meeting at which a quorum is present may continue to do business until adjournment, notwithstanding the withdrawal of enough Voting members to leave less than a quorum.

- 2.7 Voting Rights. There shall be one person with respect to each Unit ownership who shall be entitled to vote at any meeting of the Unit Owners (the "Voting Member"). The Voting Member may be the Owner, or one of a group composed of all of the Owners of a Unit, or may be some other person designated by such Owner(s) to act as proxy on his or their behalf, and who need not be an Owner. Each Owner or group of Owners (including the Board, if the Board or its designee shall then hold title to one or more Units) shall be entitled to one (1) vote for each Unit owned.
- 2.8 Majority Vote. The vote of a majority of the Voting Members present at a meeting at which a quorum shall be present shall be binding upon all Unit Owners for all poses except where a higher percentage vote is required by the Declaration, these By-Laws or by law.
- 2.9 Proxies. The Voting Members may vote either in person or by agents duly authorized by written proxy executed by such Unit Owner or his duly authorized

attorney-in-fact. A proxy shall be valid only for the particular meeting designated therein, unless the person executing it specifies therein the length of time for which it is to continue in force, which time shall not extend beyond eleven months from the date of its execution. Unless a proxy otherwise provides, any proxy holder may appoint in writing, substitute to act in his place. In order to be effective, all proxies must be filed with the secretary or duly acting secretary of the Association, either during or prior to the meeting in question.

- 2.10 Waiver or Notice. Any Voting Member may, at any time, waive notice of any meeting of the Association in writing, and such waiver shall be deemed to be equivalent to the giving of such notice. Attendance by a Voting Member at any meeting of the Association shall constitute a waiver of notice by him of the time and place thereof, except where a Voting Member attends a meeting for the express purpose of objecting to the transaction of any business because the meeting was not lawfully called. If all of the Voting Members are present at any meeting of the Unit Owner, no notice shall be required, and any business may be transacted at said meeting.
- 2.11 Informal Action by Unit Owners. Any action which may be taken at a meeting of the Association may be taken without a meeting if a consent in writing, setting forth the action so taken, shall be signed by all of the Voting Members and filed with the secretary of the Association to be kept in the Association's minute book.

ARTICLE III.
Executive Board

- 3.1 Number. The business and property of the Condominium shall be managed and directed by the Executive Board (the "Board"), composed of three (3) persons, or by such executive committees as the board may establish pursuant to the By-Laws; provided, however, that the initial Board shall be composed of three persons.
- 3.2 Initial Members. The initial members of the Board (referred to as "directors" herein) shall be selected by the Declarant, and need not be Unit Owners. Such initial directors shall serve at the election of the Declarant from the date upon which the Declaration is recorded in the Brazos County Clerk's Office until such time as their successors are elected and qualified.

The names of the persons who shall serve on the initial Board from the date upon which the Declaration is recorded in the Brazos County Clerk's Office until such time as their successors are duly elected and qualified, are as follows:

Alton E. Ofczarzak, II;
Vicki Friedberg; and
Monica Longoria.

- 3.3 Election. Except as provided herein, the directors shall be elected at the annual meeting of the Association, and those persons who receive the highest number of votes shall be deemed to have been elected. Notwithstanding anything herein to the contrary, the Board shall consist of three (3) directors during the period that Declarant is entitled to appoint a majority of the directors. The Declarant shall have the right to point all of the directors until the earlier of the following four dates: (a) the date one hundred twenty (120) days after the Declarant has conveyed seventy-five percent (75%) of the maximum number of Units which Declarant may create on the Phase 1 of the property and on the Additional Real Estate to Unit Owners other than a Declarant, or the date upon which Declarant surrenders control of the Condominium to the Unit Owners, or (c) the date two (2) years after Declarant has ceased to offer Units for sale in the ordinary course of business, or (d) the date two (2) years after any development right to add Additional Units under the Act was last exercised by Declarant.

Declarant may turn over control of the Association to such Unit Owners other than Declarant prior to such dates in its sole discretion by causing all or part of its appointed directors to resign, whereupon it shall be the affirmative obligation of Unit Owners other than Declarant to elect directors and assume control of the Association. Provided at least thirty (30) days' notice of Declarant's decision to cause its appointees to resign is given to Unit Owners, neither Declarant, nor such appointees, shall be liable in any manner in connection with such resignations even if the Unit Owners other than Declarant refuse or fail to assume control.

Within sixty (60) days after conveyance of twenty-five percent (25%) of the maximum number of Units which Declarant may create on Phase 1 of the property and on the Additional Real Estate to Unit Owners other than Declarant, at least one director and not less than twenty-five percent (25%) of the directors of the Board shall be selected by Unit Owners other than Declarant. Within sixty (60) days after conveyance of fifty percent (50%) of said maximum number of Units to Unit Owners other than Declarant, not less than thirty-three percent (33 %) of the directors of the Board shall be elected by Unit Owners other than Declarant.

Within sixty (60) days after the Unit Owners other than Declarant are entitled to such director or directors, or sooner if Declarant has elected to accelerate such event as aforesaid, the Association shall call, and give not less than ten (10) days' nor than fifty (50) days' notice of a meeting of the Unit Owners to elect such director or directors of the Board. The meeting may be called and the notice given by Unit Owner if the Association fails to do so.

The size of the Board may be increased or decreased from time to time upon the affirmative vote of three-fourths (3/4) of all Unit Owners, provided that said Board shall not be less than three (3) in number.

- 3.4 Term and Qualification. Each director shall hold office for the term for which he was elected, or until his death, resignation, retirement, removal, disqualification or until his successor is elected and qualified. At the meeting of the Association in which the Unit Owners are entitled to elect a majority of the directors, the directors of the Board shall be divided into three (3) classes; the first class to consist of one (1) director. The second class to consist of one (1) director, and the third class to consist of one (1) director. The director of the first class shall initially hold office for a term of three (3) years; the director of the second class shall initially hold office for a term of two (2) years; and the director of the third class shall initially hold office for a term of one (1) year. At all annual elections thereafter, one director shall be elected by the voting members to succeed the director whose terms then expires. Each such director shall serve for a three (3) year term. So long as Declarant shall own one (1) or more Units, the director of the Board which Declarant has the right to designate shall be a member of the third class. Nothing herein contained shall be construed to prevent the election of a director to succeed himself. Each director, except those selected by Declarant pursuant to the By-Laws, shall be one of the Unit Owners or co-owners, or a spouse of a Unit Owner or co-owner provided, however, that in the event a Unit Owner is a corporation, partnership, trust or other legal entity other than a natural person or persons, then an officer or director of such corporation, partner of such partnership, beneficiary of such trust or manager of such other legal entity, shall be eligible to serve as a director.
- 3.5 Removal. Directors may be removed from office with or without cause by the affirmative vote of at least sixty-seven percent (67%) of the Voting Members. If any directors are so removed, new Board members may be elected at the same meeting; provided, however, that the person(s) selected by Declarant cannot be removed without the prior written consent of Declarant.
- 3.6 Vacancies. A vacancy occurring in the Board may be filled by a majority of the remaining directors, though less than a quorum, or by the sole remaining director; but a vacancy created by an increase in the authorized number of directors shall be filled only by election at an annual meeting or a special meeting of Unit Owners called for that purpose. The Voting Members may elect a director at any time to fill any vacancy not filled by the Board.

In the event that Declarant, in accordance with the rights herein established, selects any person to serve on any Executive Board of the Association, Declarant shall have the absolute right at any time, in its sole discretion, to replace such person with another person to serve on any Board. Replacement of any person designated by Declarant to serve on the Board shall be made by written instrument delivered to any officer of the Association, which instrument shall specify the name of the person to be replaced and the name of the person designated as successor to the person so removed from the Board. The removal of any such Board member and

the designation of his successor shall be effective immediately upon delivery of such written instrument by Declarant to any officer of the Association.

- 3.7 Compensation. The Board Members shall receive no compensation for the services unless expressly allowed by the Board at the direction of the Unit Owners other than the Declarant having two-thirds (2/3) of the total votes.
- 3.8 Executive Committees. The Board may, by resolution adopted by a majority of the number of directors fixed by these By-Laws, designate two or more of its members to constitute an executive committee, which committee, to the extent provided in such resolution, shall have and may exercise all of the authority of the Board in the management of the Condominium.

The Board may, in like manner, create such other committees as it deems necessary and appropriate in aiding the Board to carry out its duties and responsibilities with respect to the management of the Condominium.

- 3.9 Powers and Duties. The Board shall have the powers and duties necessary for the administration of the affairs of the Condominium, and may do all such acts and things, except such acts as by law or the Declaration or by these By-Laws may not be delegated to the Board. Such powers and duties of the Board shall include, but shall not be limited to, the following:
- a) Determining the Common Expenses required for the affairs of the Condominium, including, without limitation, the operation and maintenance of the Property.
 - b) Collecting the Common Expenses from the Unit Owners.
 - c) Supervising the operation, care, upkeep and maintenance of the Common Elements.
 - d) Employing and dismissing the personnel necessary for the maintenance and operation of the Common Elements.
 - e) Adopting and amending such reasonable rules and regulations as it may deem advisable for the maintenance, conservation and beautification of the Property, and for the health, comfort, safety and general welfare of the owners and occupants of the Property. Written notice of such rules and regulations shall be given to all Unit Owners and occupants, and the entire Property shall at all times be maintained subject to such rules and regulations.

- f) Opening bank accounts on behalf of the Condominium and designating the signatories required therefor.
- g) Selling, mortgaging, voting the votes appurtenant to or otherwise dealing with Units acquired by the Association, or its designee, corporate or otherwise, on behalf of all Unit Owners, subject to the Declaration and other applicable restrictions, and organizing corporations to act as designees of the Board in acquiring title to Units on behalf of all Unit Owners.
- h) Maintaining and repairing any Unit, if such maintenance or repair is necessary in the discretion of the Board or by operation of applicable restrictions to protect the Common Elements, or any other portion of the Property, and a Unit Owner has failed or refused to perform such maintenance or repair within a reasonable time after written notice of the necessity of said maintenance or repair has been delivered or mailed by the Board to said Unit Owner; provided, that the Board shall levy a specific assessment against such Unit Owner for the costs of said maintenance or repair, including a reasonable amount of supervision.
- i) Entering any Unit when necessary in connection with any maintenance or construction for which the Board is responsible; provided, that except in the event of emergencies, such entry shall be made during reasonable hours with as little inconvenience to the Unit Owner as practical, and any damage caused thereby shall be repaired by the Board, with such expenses being treated as a Common Expense.
- j) Signing all agreements, contracts, deeds and vouchers for the payment of expenditures and other instruments in such manner as from time to time shall be determined by written resolution of the Board. However, any contracts or leases executed on behalf of the Association prior to the passage of control of the Board to the Association must be terminable by the Association without penalty on not more than ninety (90) days' written notice. In the absence of such determination by the Board, such document shall be signed by the treasurer and countersigned by the President.
- k) Obtaining insurance for the Property, including the Units, pursuant to the applicable provisions of the Declaration.
- l) Making or contracting for repairs, additions and improvements to or alterations or restoration of the property in accordance with the other provisions of these By-Laws and the Declaration, after damage or destruction by fire or other casualty, or as a result of condemnation or eminent domain proceeding.

- m) Contracting for all goods, services and insurance, payment for which is to be made from the Common Expense fund.
- n) Instituting, defending, or intervening in litigation or administrative proceedings in the name or of on behalf of the Association or two or more Unit Owners on matters affecting the Condominium.
- o) Borrowing money on behalf of the Condominium when required in connection with the operation, care, upkeep and maintenance of the Common Elements or the acquisition of property, and granting mortgages on and/or security interests in Association owned property; provided, however, that the consent of the Unit Owners of at least two-thirds (2/3rds) of the Units represented at a meeting at which a quorum has been attained in accordance with the provisions of these By-Laws shall be required for the borrowing of any sum in excess of \$10,000.00.
- p) Imposing charges for late payment of assessment and, after notice and an opportunity to be heard, levy reasonable fines for violations of the Declaration, the By-Laws, or rules and regulations established by the Association, all in accordance with Section 82.113 of the Act.
- q) At its discretion, authorizing Unit Owners or other persons to use portions of the Common Elements for private parties and gatherings and imposing reasonable charges for such private use.
- r) Exercising each of the following: (i) all powers specifically set forth in the Declaration, the Certificate of Formation, these By-Laws and in the Act, (ii) all powers incidental thereof, and (iii) all other powers of a non-profit Texas corporation.
- s) Suspending the right of any Unit Owner to vote as long as said Unit Owner is delinquent in the payment of Common Expenses or is otherwise in violation of the Declaration or any exhibits thereto or applicable rules and regulations.

3.10 Managing Agent. The Board may engage the services of any person, firm, or corporation to act as managing agent at a compensation established by the Board, to perform such duties and services as the Board shall authorize, other than the powers set forth in subdivisions (a), (e), (g), (h), (i), (p), and (q) of Section 3.9 of this Article III. Any management agreement for the Condominium shall be terminable by either party without cause and without payment of a termination fee or penalty upon 90 days or less written notice thereof and the terms of such agreement may not exceed one year, renewable by agreement of the parties for successive one year

periods. Any management agreement shall be terminable by either party for cause upon the giving of not more than thirty (30) days written notice. When professional management has been previously required, any decision to establish self-management by the Association shall require the prior consent of sixty-seven (67%) percent of the Unit Owners, and in addition, when professional management has been previously required by any Eligible Mortgage Holder the decision to establish self-management by the Association shall require the approval of fifty-one percent (51%) of the Eligible Mortgage Holders, counting one vote for each first mortgage owned.

3.11 Duties of Declarant. Within a reasonable time after Unit Owners other than the Declarant elect a majority of the members of the Board (but not more than sixty (60) days after such event), the Declarant shall deliver control of the Association and shall deliver to the Association all property [noted in Subsection (a) through (o)] of the Unit Owners and of the Association held or controlled by the Declarant, including, if applicable:

- a) The original or a photocopy of the recorded Declaration of the Condominium, and all amendments thereto. If a photocopy is provided, Declarant must certify by affidavit that it is a complete copy of the actual recorded Declaration.
- b) A copy of the Certificate of Formation of the Association.
- c) A copy of the By-Laws of the Association.
- d) The minute books, including all minutes, and other books and records of the Association.
- e) Any rules and regulations which have been adopted.
- f) Resignations of resigning officers and Board members.
- g) Association funds or the control thereof.
- h) A copy of the plans and specifications utilized in the construction or remodeling of improvements on the Property and the supplying of equipment; and for the construction and installation of all mechanical components servicing the improvements and the Condominium, with a certificate, in affidavit form, of an officer of Declarant or an architect or engineer authorized to practice in Texas, that such plans and specifications represent, to the best of their knowledge and belief, the actual plans and specifications utilized in the construction or improvement of the Condominium and the construction or installation of the mechanical

components servicing the Improvements and the Condominiums.

- i) Insurance policies.
- j) Copies of any Certificates of Occupancy which may have been issued for the Condominium.
- k) Any other permits issued by governmental bodies applicable to the Condominium in force or issued within one (1) year prior to the date the Unit Owners take control of the Association.
- l) All written warranties of contractors, subcontractors, suppliers and manufacturers, if any, that are still effective.
- m) A roster of Unit Owners and their addresses and telephone numbers, if known, as shown on Declarant's records.
- n) Employment contracts or service contracts in which the Association is one of the contracting parties, or service contracts in which the Association or Unit Owners have an obligation or responsibility, directly or indirectly, to pay some or all of the fee or charge of the person or persons performing the service.
- o) All other contracts to which the Association is a party.

ARTICLE IV.
Meetings of Directors

- 4.1 Organizational Meeting. The first meeting of the initial Board designated in these By-Laws shall be held at such time as Declarant shall determine, but in no event later than one year from the date of incorporation of the Association. The first meeting of a newly elected Board shall be held within fifteen (15) days following the meeting of the Unit Owners at which the Board was elected. No notice shall be necessary to the newly elected members of the Board in order to legally constitute such meeting, providing that a quorum is present.
- 4.2 Regular Meeting. A regular meeting of the Board shall be held immediately after, and at the same place as, the annual meeting or substitute annual meeting of the Unit Owners. In addition, the Board may provide by resolution the time and place, either within or without the State of Texas for the holding of a regular meeting of the Board, with such meeting to be held as decided by the Board during each fiscal year.

- 4.3 Special Meetings. Special meetings of the Board may be called by or with the request of the chairman, or by any two (2) directors. Such meetings may be held either within or without the State of Texas.
- 4.4 Notice of Meetings. Regular meeting of the Board may be held without notice. The person(s) who called a special meeting of the directors shall, at least two (2) days prior to said meeting, give notice thereof by any usual means of communication. Such notice need not specify the purpose for which the meeting is called.
- Attendance by a director at a meeting shall constitute a waiver of notice of such meeting except where a member attends the meeting for the express purpose of objecting to the transaction of any business because the meeting was not lawfully allowed. Meeting of the Board shall be open to all Unit Owners and notices of meeting shall be posted conspicuously for the attention of Unit Owners in advance of the meeting, except for regular meeting of the Board, which may be held without notice.
- 4.5 Waiver of Notice. Any member of the Board may at any time waive notice of any meeting of the Board in writing, and such waiver shall be deemed equivalent to the giving of such notice. Attendance by a director at any meeting of the Board shall constitute a waiver of notice by him of the time and place thereof. If all of the directors present at any meeting of the Board, no notice shall be required, and any business be transacted at such meeting.
- 4.6 Quorum. A majority of the number of directors fixed by these By-Laws shall be required for and constitute a quorum for the transaction of business at any meeting of the Board.
- 4.7 Manner of Acting. Except as otherwise provided in this Section, the act of the majority of the directors present at a meeting at which a quorum is present shall be the act of the Board. A vote of a majority of the number of directors fixed by these By-Laws shall be required to adopt a resolution constituting an executive committee. Vacancies in the Board may be filled as provided in Section 3.6 of these By-Laws.
- 4.8 Organization. Each meeting of the Board shall be presided over by the Chairman, and in the absence of the Chairman, by a person selected to preside by vote of the majority of the Board members present. The secretary, or in his absence, an assistant secretary, or in the absence of both the secretary and the assistant secretary, any person designated by the chairman of the meeting shall act as secretary of the meeting.

- 4.9 Informal Action of Board. Action taken by a majority of the directors without a meeting nevertheless Board action if written consent to the action in question is signed by all directors and filed with the minutes of the proceedings of the Board, whether before or after the action so taken.
- 4.10 Minutes. The Board shall keep minutes of its proceedings, which shall be available for inspection by the Unit Owners during reasonable business hours.
- 4.11 Liability of the Board and Officers. The directors and the officer provided for in Article IV hereof shall not be liable to the Unit Owners for any mistake of judgment, negligence or otherwise, except for their own individual willful misconduct or bad faith. The Unit Owners shall indemnify and hold harmless each of the directors and the officers against all contractual liability to others arising out of contracts made by the Board or the officers on behalf of the Condominium, unless any such contract shall have been made in bad faith or contrary to the provisions of the Declaration or these By-Laws. It is intended that the directors or any officer shall have no personal liability with respect to any contract made by them on behalf of the Condominium, except to the extent that they are Unit Owners and have liability as such. It is also intended that the liability of any Unit Owner arising out of any contract made by the Board or the officers, or out of the aforesaid indemnity in favor of the directors or the officers, shall be limited to such proportion of the total liability thereunder as his interest in the Common Elements bears to the interests of all the Unit Owners in the Common Elements. Every agreement made by the Board, by the managing agent or by the officers on behalf of the Condominium shall provide that the members of the Board, the managing agent or the officers, as the case may be, are acting only as agents for the Unit Owners, and shall have no personal liability thereunder.

ARTICLE V.
Officers

- 5.1 Number. The principal officers of the Condominium shall consist of a Chairman of the Board, a secretary, a treasurer, and, if the management of the Condominium becomes self-directed by the Board, such vice chairmen, assistant secretaries, assistant treasurers and other officers as the Board may from time to time elect. Any two or more offices may be held by the same person, except the offices of chairman and secretary.
- 5.2 Election and Term. The officers of the Condominium shall be elected by the Board. The chairman, vice chairman, secretary and treasurer shall be elected from among the Board and all other officers, if any, need only be a Unit Owner. The officers elected by the initial Board are not required to be Unit Owners. The election of officers may be held at the regular annual meeting of the Board. Each officer shall hold office for a period of one year or until his death, resignation, retirement,

removal, disqualification, or until his successor is elected and qualifies.

- 5.3 Removal. Any officer or agent elected or appointed by the Board may be removed by the Board, with or without cause; but such removal shall be without prejudice to the contract rights, if any, of the person so removed.
- 5.4 Compensation. No officer shall receive any compensation from the Condominium for acting as such.
- 5.5 Chairman of the Board. The Chairman of the Board shall be the principal executive officer of the Condominium; and, subject to the control of the Board, shall supervise and control the management of the Condominium. The chairman shall, when present, preside at all meetings of the Board and of the Unit Owners and, in general, shall perform all duties incident to the office of chairman of the Board, and such other duties as may be prescribed from time to time by the Board.
- 5.6 Vice Chairman. The vice chairman, and if there be more than one, the vice chairmen, designated by the Board, shall, in the absence or disability of the chairman, have the powers and perform the duties of said office. In addition, each vice chairman shall perform such other duties and have such other powers as shall be prescribed by the Chairman of the Board.
- 5.7 Secretary. The secretary shall keep accurate records of the acts and proceedings of all Meeting of the Unit Owners and directors. He shall give, or cause to be given, all notice required by law and by these By-Laws. He shall have general charge of the minute books and records of both the Association and the board. He shall sign such instruments as may require his signature, and, in general, shall perform all duties incident to the office of secretary, and such other duties as may be assigned from him from time to time by the chairman of the Board or by the Board.
- 5.8 Treasurer. The treasurer shall have custody of all Condominium funds and securities, and shall receive, deposit or disburse the same under the direction of the Board. He shall keep full and accurate accounts of the finances of the Condominium in books especially provided for that purpose. He shall cause a true statement of its assets and liabilities as of the close of each fiscal year, and of the results of its operations and changes in surplus for each fiscal year, all in reasonable detail, to be prepared and distributed to all Unit Owners and members of the Board on or before the 15th day of the second month following the close of each fiscal year. The statement so filed shall be kept available for inspection by a Unit Owner for a period of three (3) years. The treasurer shall also prepare and file all reports and returns required by federal, state or local Law, and shall generally perform all other duties as may be assigned to him from time to time by the chairman of the Board.

- 5.9 Assistant Secretaries and Treasurers. The assistant secretaries and assistant treasurers, if any, shall, in the absence of the secretary and treasurer, respectively, have all the powers and perform all of the duties of those officers, and they shall in general perform such other duties as shall be assigned to them by the secretary or the treasurer, respectively, or by the chairman of the Board or the Board.

ARTICLE VI.
Operation of the Property

- 6.1 Initial Assessment. At its organizational meeting the Board shall adopt a proposed budget for the Condominium and shall levy assessments against the Units for Common Expenses based upon said budget, which assessments shall commence in accordance with the provisions of Section 6.4 of the Declaration. The assessments so levied shall remain in effect until future assessments are determined in accordance with the provisions of Section 6.2 of these By-Laws.
- 6.2 Assessment and Determination of Common Expenses. The Board shall from time to time, and at least annually, prepare a budget for the Condominium, for the purpose of determining the amount of the Annual Assessments to be collected from the Unit Owners in order to provide for the Common Expenses of the Condominium, and allocate and assess such Common Expenses amount to the Unit Owners, according to their Percentage of Interest in the Common Elements as set forth in the Declaration, taking into consideration any expected income and any surplus from the prior year's operation. The Common Expenses shall include, without limitation, the expenses, costs and charges incurred in connection with the administration, operation and management of the Condominium property; the cost of maintenance, repair, replacement and restoration of the Common Elements, or any part thereof; the cost of all insurance premiums on all policies of insurance required to be or which have been obtained by the Board pursuant to the provisions of the Declaration; such amounts as the Board may deem proper for the convenience, comfort and well-being of the Unit Owners, and for the operation, management and maintenance of the Property, including, without limitation, an amount for working capital of the Condominium, for a general operating reserve, for a reserve fund for replacements, and to make up any deficit in the Common Expenses for any prior year; in proper cases, the cost of administration and of maintenance and repair of the Limited Common Elements; and any other expenses lawfully agreed upon.

In establishing a reserve fund for replacements, the board shall take into account the number and nature of replaceable assets, the expected life of each asset, and the expected repair or replacement cost. The Board shall then set the required capital contribution in an amount sufficient to permit meeting the projected capital needs of the Association with respect to both amount and timing by equal annual installments over the applicable period.

Within thirty (30) days after adoption by the Board of any proposed budget for the Condominium, the Board shall provide a summary of the budget to all Unit Owners and shall give notice of a date for a meeting of the Unit Owners to consider ratification of the budget not less than fourteen (14) nor more than thirty (30) days after mailing of the summary and notice. A quorum need not be present at the meeting. The budget is ratified unless at the meeting a majority of all the Unit Owners votes to reject the budget. In the event the proposed budget is rejected, the periodic budget last ratified shall be continued until such time as the Unit Owners ratify a subsequent budget proposed by the Board. Provided, however, the requirements of this Section relating to budget adoption shall not be applicable to the adoption of the initial budget or the levy of the initial assessment by the Board at its organizational meeting as provided for Section 6.1 hereof.

- 6.3 Payment of Assessments. All Unit Owners shall be obligated to pay (1) Annual Assessments to Common Expenses assessed by the Board pursuant to the provisions of is Article VI; (2) special assessments to be established and collected as provided herein, and (3) specific assessments against any Unit which are established pursuant to the terms of these By-Laws. Annual Assessments shall be due and payable in monthly installments on the first day of every month. A later payment charge in an amount to be determined by the Board shall be assessed for any installment not paid by the tenth of the month. Any installment not paid during the month in which it is due shall be subject to the late payment charge and shall accrue interest as provided in Section 6.5, and shall constitute a lien on the Unit as provided in Section 6.6 of this Article VI.

No Unit Owner shall be liable for the payment of any part of the Common Expenses assessed against his Unit subsequent to a sale, transfer or other conveyance by him (made in accordance with the provisions of the Declaration and applicable restrictions record) of such Unit, together with his interest in the Common Elements. A purchaser of a Unit shall be jointly and severally liable with the seller for the payment of Assessments assessed against such Unit prior to the acquisition by the purchaser of such Unit only if the purchaser expressly assumes such obligation in writing; provided, however, the lien assessed against such unit shall remain in full force and effect. Any such purchaser shall be entitled to a statement from the Board setting forth the amount of the unpaid Assessments against the seller, and the Unit conveyed shall not be subject to a lien for any unpaid assessments in excess of the amount shown on the statement. Provided, however, that a First Mortgagee or other purchaser of a Unit at Foreclosure sale of such Unit or a First Mortgagee who takes a deed in lieu of foreclosure shall not be liable for, and such Unit shall not be subject to, a lien for the payment of Common Expenses assessed prior to the foreclosure sale or deed in lieu of foreclosure. Such unpaid Common Expenses shall be deemed to be Common Expenses collectible from all of the Unit Owners, including such purchaser, his successors or assigns.

6.4 Special Assessments. The Association may levy Special Assessments for Common Expenses not covered by the Annual Assessment, applicable to that year only for the purpose of defraying, in whole or in part, the cost of any construction, reconstruction, repair or replacement of a capital improvement upon the Common Elements, including fixtures and personal property related thereto, provided that any such Assessment shall have the assent of two-thirds (2/3) of the Voting Members at a meeting duly called for this purpose. Such Special Assessments shall be charged to the Units according to their Percentage Interest in the Common Elements. In addition, the Board may levy Special Assessments against one or more, but less than all, of the Units to cover repairs or maintenance for which such Unit Owner or Owners are responsible and which they have failed to make, or for repairs or maintenance required of a Unit Owner or Unit Owners which impair the value of the Common Elements or the Unit or Units, or expenses which are incurred in the abatement of or as a result of a violation by a Unit Owner or Owners of the provisions of the Declaration, the By-Laws or the rules, regulations, or for fines levied for said violations, or where the Board has purchased a Unit on behalf of one or more Unit Owners. The period of assessment and manner of payment of such assessment shall be determined by the Board.

6.5 Collection of Assessments. The Board shall determine Common Expenses against the Unit Owners from time to time, at least annually, and may, as the Board shall determine, take prompt action to collect any Assessments due from any Unit Owner which remain unpaid for more than thirty (30) days from their due date.

The Board shall notify Eligible Mortgage Holders pursuant to the provisions of the Declaration for which any amount assessed pursuant to these By-Laws remains unpaid for more than sixty (60) days from their due date, and in any other case where the Unit Owner of such Unit is in default with respect to the performance of any obligation hereunder for a period in excess of sixty (60) days.

6.6 Default in Payment of Assessment. In the event of default by any Unit Owner in paying to the Board any amounts assessed by the Board, such Unit Owner shall be obligated to pay a late payment charge of fifteen (\$15.00) dollars or such rate as established by the Board from time to time, and interest at the initial rate of ten percent (10%) per annum on such amounts from their due date or at a rate as established by the Board; together with all expenses, including reasonable attorneys' fees (if permitted by law), incurred by the Board in collecting such unpaid sums. If a Unit Owner shall be in default in payment of an installment of an Assessment, including but not limited to, the monthly installment based on the annual budget, the Board may accelerate the remaining installments upon ten (10) days' written notice to such Unit Owner, whereupon the entire unpaid balance of such Assessment shall become due upon the date dated in such notice.

- 6.7 Lien and Personal Obligation. Each Assessment provided for in this Article, together with late payment charges, interest and expenses, including attorneys' fees (as permitted by law), shall be a charge on and a continuing lien upon the Unit against which the Assessment is made when a notice of such lien has been filed of record in the Office of the County Clerk of Brazos County, Texas, provided such notice of lien not be recorded until such sums assessed remain unpaid for a period of thirty (30) days after the same shall become due. Said notice of lien shall also secure all Assessments against the Unit becoming due thereafter until the lien has been satisfied. Said lien may be foreclosed non-judicially pursuant to the power of sale created by action 82.113 of the Act in the manner as a deed of trust on real property. In addition, each Unit Owner shall be personally liable for any Assessment against his Unit becoming due and payable while he is the Owner of such Unit.
- 6.8 Priority of Assessment Lien. The lien of the Assessments provided for in this Article shall be prior and superior to all other liens except (a) ad valorem taxes, and (b) all sums unpaid on first lien deeds of trust, mortgages or other encumbrances against the Unit prior to the docketing of the Assessment lien. The sale or transfer of any Unit shall not affect the Assessment lien against such Unit. Provided, however, the sale of a Unit pursuant to the foreclosure sale or execution sale instituted by a superior lien holder or conveyance to First Mortgagee by deed in lieu of foreclosure shall extinguish the inferior Assessment lien against the subject Unit but no such sale or transfer shall relieve each Unit from liability for any Assessments thereafter becoming due or for any future lien in connection therewith. The Association shall share in the excess, if any, realized by the sale of any Unit pursuant to a foreclosure or action instituted by a superior lien holder, to the extent of its lien.
- 6.9 Foreclosure of Liens for Unpaid Assessments. Following the institution of any action by the Board to foreclose on a Unit because of unpaid Assessments, the Unit Owner shall pay a reasonable rental for the use of his Unit, and the plaintiff in such foreclosure action shall be entitled to the appointment of a receiver to collect the rental. The Board, acting on behalf of the Association, on behalf of any one or more individual Unit Owners, if so instructed, shall have the power to purchase such Unit at the foreclosure sale and to acquire, hold, lease, mortgage, vote the votes appurtenant to, convey or otherwise deal with the same, subject, however, to applicable restrictions of record. A suit to recover a money judgment for unpaid Assessments shall be maintainable without foreclosing or waiver of the Assessment lien. Where a First Mortgagee or the purchaser of a Unit obtains title to the Unit as a result of foreclosure of the First Mortgage, such purchaser, its successors and assigns, shall not be liable for the share of the Common Expenses or Assessments by the Board chargeable to such Unit which become due prior to the acquisition of title to such Unit by such purchaser. Such unpaid share of Common Expenses or Assessments shall be deemed to be a Common Expense collectible from all Unit Owners, including such purchaser, its successors and assigns.

- 6.10 Statement of Common Expenses. The Board shall promptly provide any Unit Owner so requesting the same in writing with a written statement of all unpaid charges due from such Unit Owner, for which it may institute a reasonable charge at its discretion.
- 6.11 Abatement and Enjoinment of Violations by Unit Owners. The violation of any rule or regulation adopted by the Board or the breach of any bylaw contained herein, or the reach of any provision of the Declaration, shall give the Board the right, in addition to any other rights set forth in these By-Laws: (a) to enter the Unit in which, or as to which, such violation or breach exists, and to make any repairs, and to summarily abate and remove, at the expense of the defaulting Unit Owner, any structure, thing condition which may exist therein contrary to the intent and meaning of the provisions hereof, and the Board shall not thereby be deemed guilty in any manner of trespass; (b) to enjoin, abate, or remedy by appropriate legal proceedings, either at law or in equity, the continuance of any such breach at the expense of the defaulting Unit Owner; (c) in any case of flagrant or repeated violation by a Unit Owner, to require such Unit Owner to give sufficient sureties for his future compliance with such Condominium documents; or (d) after notice and an opportunity to be heard, to levy reasonable assessments and fines in accordance with Sections 82.112, 82.113 and 8 2.117 of the Act for such violations. The failure of the Board to so act with respect to any such violation or breach shall not be deemed a waiver of the Board's right to act with respect to the same or any other breach or violation.
- 6.12 Maintenance and Repair.
- a) Each Unit Owner shall maintain, repair and replace, at his sole cost and expense, all portions of his Unit which may become in need thereof, including the components of the heating and air conditioning system within and appurtenant to each Unit, if any, all bathroom and kitchen fixtures and appliances, light fixtures, interior, non-load-bearing walls, doors, floors, ceilings, carpeting, drapes and other items within the Unit, whether structural or non-structural, ordinary or extraordinary (other than maintenance of and repairs to any Common Elements not specifically set forth herein contained therein and not necessitated by the negligence, misuse or neglect of the Unit Owner, his family guest, agents, servants, lessees, employees or contractors). Each Unit Owner shall clean the Limited Common Elements appurtenant to his Unit and replace all light bulbs in fixtures (if any) located in such Limited Common Elements. Each Unit Owner shall be responsible for replacing all heating and air conditioning filters, if any, required in his Unit. Each Unit Owner shall further be responsible for all damages to any and all other Units and/or to the Common Elements which his failure to undertake his maintenance

responsibility may engender. All damages to the Common Elements or other Units intentionally or negligently caused by the Unit Owner, his family, guests, agent, servants, lessees, employees or contractors shall be promptly repaired by the Unit Owner at his sole cost and expense; provided that there is excluded from the provisions contained in this section such repairs necessitated by casualties insured against by the Association to the extent the Association receives insurance proceeds for such repairs. In such event, the Unit Owner shall be required to pay such portion of the costs of such maintenance, repair and replacement as shall exceed the amount of the applicable insurance proceeds. If the Unit Owner does not make those repairs to be made by him within thirty (30) days from written demand by the Board, the same may be repaired by the Board, and the cost thereof shall be assessed against the Unit owned by the subject Unit Owner.

- b) The Association, through its Board, shall maintain, repair and replace all portions of the Common Elements and Limited Common Elements (except as provided in Section 6.12(a) above) which shall require same, whether located inside or outside of the Units (unless necessitated by the negligence, misuse or neglect of a Unit Owner, his family, guests, agents, servants, lessees, employees or contractors, in which case such expense shall be charged to such Unit Owner, or unless herein provided to the contrary), and the cost thereof shall be charged to all the Unit Owners as a Common Expense.

- 6.13 Restrictions on Unit Owners. No Unit Owner shall perform or cause to be performed any maintenance, repair or replacement work which disturbs the rights of the other Unit Owners, jeopardizes the soundness or the safety of the Condominium property, or reduces the value thereof. Each Unit Owner shall cause any work so performed or being performed on the Unit, which, in the sole opinion of the board, violates the terms of this Section, to be immediately corrected, and he shall refrain from recommencing or continuing any such work without written consent of the Board.
- 6.14 Duty to Report. Each Unit Owner shall promptly report to the Board or its agent any defect or need for repairs or replacement the responsibility for which is that of the Association.
- 6.15 Additions, Alterations or Improvements by the Association. Whenever in the judgment of the Board the Common Elements shall require additions, alterations or improvements, the Board shall proceed with such additions, alterations or improvements, and shall assess all Unit Owners for the costs thereof, as a Common Expenses, subject, however, to the provisions of Sections 6.2 and 6.3 of this Article.

- 6.16 Additions, Alterations or Improvements by Unit Owners. No Unit Owner shall make any addition, alteration or improvement in or to his Unit, which impairs the structural integrity or mechanical systems or lessens the support of any part of the Condominium. No Unit Owner shall make any addition, alteration or improvement which affects the exterior portion or outward appearance of such Unit, without the prior written consent thereof of the Board. The Board shall have the obligation to answer any written request by a Unit Owner for approval of a proposed addition, alteration or improvement in or to such Unit Owner's Unit within thirty (30) days after such request, and the failure to do so within the stipulated time shall constitute a consent by the Board to the proposed addition, alteration or improvement.
- 6.17 Use of Common Elements and Facilities. A Unit Owner shall not interfere with the use of the Common elements by the remaining Unit Owners and their guests.
- 6.18 Right of Access. A Unit Owner shall grant a right of access to his Unit to the managing agent and/or any other person authorized by the Board or the managing agent, for the purpose of making inspections or for the purpose of correcting any condition originating in his Unit and threatening another Unit or a Common Element, or for the purpose of performing installations, alterations or repairs to the mechanical or electrical services or other Common Elements in his Unit or elsewhere in the building, or to correct any condition which violates the provisions of any mortgage covering another Unit, provided that requests for entry are made in advance, and that any such entry is at a time reasonably convenient to the Unit Owner. In the case of an emergency, such right of entry shall be immediate, whether or not the Unit Owner is present at the time such request for entry is made, or such entry is at a time reasonably convenient to the Unit Owner.
- 6.19 Rules of Conduct. Rules and regulations concerning the use of the Units and the Common Elements may be promulgated and amended by the Board. Such rules and regulations shall be equally applicable to all Unit Owners similarly situated and shall be uniform in their application and effect. Copies of such rules and regulations shall be furnished by the Board to each Unit Owner prior to their effective date.
- 6.20 Remedies Cumulative. All right, remedies and privileges granted to the Association or the Owner or Owners of a Unit pursuant to any terms, provisions, covenants or conditions of the Declaration or other above-mentioned documents, shall be cumulative, and the exercise of any one or more shall not constitute an election of remedies, nor shall it preclude the party thus exercising the same from exercising such and additional rights, remedies or privileges as may be available to such party at law or in equity.

6.21 Nonwaiver of Remedies.

- (a) The failure of the Association or any Unit Owner to enforce any right, provision, covenant or condition which may be granted by the Declaration or the other above-mentioned documents shall not constitute a waiver of the right of the Association or of the Unit Owner to enforce such rights, provision, covenant or condition in the future.
- (b) The failure of Declarant to enforce any rights, privilege, covenant or condition which may be granted to it by the Declaration or other above-mentioned documents shall not constitute a waiver of the right of Declarant to thereafter enforce such right, provisions, covenant or condition in the future.
- (c) The failure of a First Mortgagee to enforce any right, provisions, privilege, covenant or condition which may be granted to it or them by the Declaration or other above-mentioned documents, shall not constitute a waiver of the right of said party or parties to thereafter enforce such right, privilege, covenant or condition in the future.

ARTICLE VII.

Records and Audits

- 7.1 Reports. The Board shall keep detailed records of the actions of the Board and the managing agent, minutes of the meeting of the Board, minutes of the meetings of the Association, and financing records and books of account of the Condominium, including a chronological listing of receipts and expenditures, as well as a separate account for each Unit, which, among other things, shall contain the amount of each Assessment against each Unit, the date when due, the amounts paid and the balance remaining unpaid. The financial records and books of account shall be available for examination by all Unit Owners, their duly authorized agents or attorneys, and all lien holders, their attorneys and authorized agents, at convenient hours that shall be set and announced for general knowledge. A written annual summary of all receipts and expenditures of the Condominium shall be rendered by the Board to all Unit Owners on or before the 15th day of the second month following the close of each fiscal year. In addition, an annual report of the receipts and expenditures of the Condominium shall be rendered by the Board to all Unit Owners and to all Eligible Mortgage Holders who have requested the same, promptly after the end of each fiscal year.
- 7.2 Common Expense Funds. All sums collected by the Association, either as Assessments for the Common Expenses or Special Assessments may be commingled in a single fund, but they shall be held for the Owners for the purposes for which they are paid, and shall, subject to the right of withdrawal or refund

provided herein, be credited to accounts from which shall be paid the charges for which the Assessments are made. Such accounts shall include the following, or such other and further accounts as the Board from time to time shall determine.

- (a) General Common Expense Account-to which shall be credited collection of non-capital expenditures;
- (b) Capital Reserve Account-to which shall be credited, all sums collected which are to be allocated for capital expenditures for the reconstruction, repair and replacement of Common Elements at a future date.

All sums collected by the Association, either as assessments of the Common Expenses or special assessments, during any fiscal year and allocated to the General Common Expense Account or to any other account from which non-capital expenditures may be made, in excess of expenditures during such fiscal year made from or chargeable to said account or accounts shall be deemed contributions to capital at the end of said fiscal year, and shall be transferred to the Capital Reserve Account. All amounts credited to said Capital Reserve Account shall be contributions to capital, and shall be held in trust by the Association for future expenditures of a capital nature, and shall serve to reduce the Assessments required for said capital expenditures.

- 7.3 Audits. All books of account and financial records shall be kept in accordance with generally accepted accounting practices. The Board shall have a review of the books of account and financial records of the Association made by an independent accountant immediately following the close of each fiscal year and the report of such accountant shall be received by the Board and made available for inspection upon request by all Units owners and all eligible Mortgage Holders on or before the 15th day of the third month following the close of each fiscal year.

ARTICLE VIII. Amendments to By-Laws

- 8.1 Notice. Notice of the subject matter of a proposed amendment shall be included in the notice of a meeting at which a proposed amendment is to be considered.
- 8.2 Adoption. A resolution for the adoption of a proposed amendment may be proposed either by a majority of the Board or by not less than one-third (1/3) of the members of the Association. Directors and members of the Association not present in person or by proxy at the meeting considering the amendment may express their approval in writing, provided that such approval is delivered to the Secretary at or prior to the meeting. The approval must be by not less than a majority of the votes of all members of the Association represented at a meeting at which a quorum has been attained.

- 8.3 Limitation. No amendment may be adopted which would eliminate, modify, prejudice, abridge or otherwise adversely affect any rights, benefits, privileges or priorities granted or reserved to the Declarant or eligible Mortgage Holders without the consent of said Declarant and Eligible Mortgage Holders in each instance. No amendment shall be made that is in conflict with the Certificate of Formation of the Association or Declaration without satisfaction of the requirements therein contained. So long as the Declarant controls the Association and the Veterans Administration holds or insures any first Mortgage on a Unit in the condominium, the Veterans Administration shall have the right to veto any amendment to the By-Laws. No amendment to this Section shall be valid.
- 8.4 Execution and Recording. A copy of each amendment shall be attached to a certificate certifying that the amendment was duly adopted as an amendment to the Declaration and By-Laws, which certificate shall be executed by the Chairman or vice chairman and attested by the Secretary or Assistant Secretary of the Association with the formalities of a deed, or by the Declarant alone if the amendment has been adopted consistent with the provisions of the Declaration allowing such action by the Declarant. The amendment shall be effective when the certificate and a copy of the amendment is recorded in the County Clerk's office in Brazos County, Texas.

ARTICLE IX.
Condemnation

- 9.1 General. Whenever all or any part of the condominium Property shall be taken by any authority having the power of condemnation or eminent domain, each Unit Owner and all Eligible Mortgage Holders shall be entitled to notice thereof and to participate in the proceedings incident thereto unless otherwise prohibited by law. The award made for such taking shall be payable to the Association. Unless otherwise provided by law at the time of such taking, any award made therefor shall be disbursed by the Association as provided in this Article IX.
- 9.2 Common Elements. If the taking is confined to the Common Elements (general or limited) on which improvements shall have been constructed, and at least eighty (80%) percent of the total vote of the members of the Association entitled to vote shall vote within sixty (60) days after such taking to replace the improvements, or any part thereof, on the remaining land included in the Common Elements (general or limited) and according to the plans therefor first approved by the Association, then the Board shall arrange for such replacement and the Association shall disburse the proceeds of such award in the same manner as they are required to disburse insurance proceeds where damage or destruction to the Common Elements (general or limited) is to be repaired or reconstructed as provided for herein; subject to, however, the right hereby reserved to the Association by a majority vote of the Voting Members, to provide for the disbursement by the Association of the

remaining proceeds held by it (after the payment of all costs incident to such replacement) to the Unit Owners or any one or more of them or to their First Mortgagees as their interest may appear in amounts proportionate to their percentages of undivided interest in the Common Elements (general or limited) established herein, which disproportionate amounts shall correspond with the disproportionate damage sustained by the Unit Owners or any one or more of them as the Association may determine. If at least eighty (80%) percent of Voting Members shall not decide within sixty (60) days after such taking to replace said improvements or if the taking is confined to the Common Elements (general or limited) on which no improvements shall have been constructed, then the Association shall disburse the proceeds of the award in the manner herein above provided for the disbursement of the remaining proceeds of an award after payment of all costs incident to the replacement of improvements taken has been made, including the right reserved to the Association to provide for the disbursement of the remaining proceeds held by it to the Unit Owners in disproportionate amounts. All disbursements made under this Section 9.2 shall be in strict compliance with Section 82.007 of the Act.

- 9.3 Units. If the taking includes one or more Units, or any part or parts thereof, whether or not there is included in the taking any part of the Common Elements (limited or general), then the award shall be disbursed and all related matters shall be handled pursuant to and in accordance with the consent of all Unit Owners and First Mortgagees affected and the Executive Board of the Association thereafter, expressed in a duly recorded Amendment to the Declaration of Condominium, all in accordance with Section 82.007 and 82.067 of the Act.
- 9.4 Termination. The Board shall call a meeting of all Unit Owners at least forty-five (45) days prior to any final taking by the condemning authority to determine the action to be taken pursuant to Sections 9.2 and 9.3 above. Except in the event of a taking of all the Units by eminent domain, in the event the condemnation involves more than ten (10%) percent of the value of the Common Elements (limited or general) and/or more than fifteen (15%) percent of the total value of all Units, the Condominium may be terminated at such meeting by written approval of not less than eighty (80%) percent of the Voting Members. Any termination agreement shall be in compliance with 82.08 of the Act.

ARTICLE X.
Miscellaneous

- 10.1 Ad Valorem Taxes. Each Unit shall be deemed to be a separate parcel and shall be separately assessed and taxed. Each Unit Owner shall be liable solely for the amount of tax assessed against his Unit and shall not be affected by the consequences resulting from the tax delinquency of other Unit Owners. All tangible personal property owned by the Association in connection with the

maintenance, upkeep and repair of the Common Elements shall be listed for said taxes in the name of and paid by the Association. Each Unit Owner is also responsible for his pro rata share of taxes assessed on his portion of the Common Elements, if any.

- 10.2 Notification to Mortgagees. Any Owner who mortgages his Unit shall notify the Association of the name and address of the Mortgagee, and the Association shall maintain such information in a book entitled "Mortgagees of Condominiums". In addition to any other notification provided for in the Declaration or these By-Laws, the Association, may, at the written request of a Mortgagee of any such Unit, report any unpaid assessments due from the Owner of such Unit. The Association shall notify each Mortgagee appearing in said book the name of each company insuring the Condominium Property under the master policy and the amounts of the coverage thereunder.
- 10.3 Severability. Invalidation of any covenant, condition, restriction or other provision of the Declaration or these By-Laws shall not affect the validity of the remaining portions thereof which shall remain in full force and effect.
- 10.4 Successors Bound. The rights, privileges, duties and responsibilities set forth in the Declaration of these By-Laws, as amended from time to time, shall run with the ownership of the Condominium Property and shall be binding upon all persons who own or hereafter acquire any interest in the Condominium Property.
- 10.5 Gender, Singular, Plural. Whenever the context so permits, the use of the singular or plural shall be interchangeable in meaning and the use of any gender shall be deemed to include all genders.
- 10.6 Principal Office-Registered Office. The initial principal office and registered office of the Association shall be located at 4060 Highway 6 South, College Station, Texas 77845.
- 10.7 Other Offices. The Association may have other offices at such other places within Texas as the Board may from time to time determine or as the affairs of the Association may require.
- 10.8 Seal. No seal shall be required for the Association.
- 10.9 Fiscal Year. The fiscal year of the Association shall be the calendar year.

CERTIFICATION

I, the undersigned, do hereby certify:

THAT I am the duly elected and acting secretary of COPPER CREEK CONDOS HOA, INC., a Texas non-profit corporation, and

THAT the foregoing By-Laws constitute the original By-Laws of said Association, as duly a meeting of the initial Executive Board thereof held on the 16th day of November, 2015.

IN WITNESS WHEREOF, I have subscribed my name and affixed the seal of said Association, this 16th day of November, 2015.

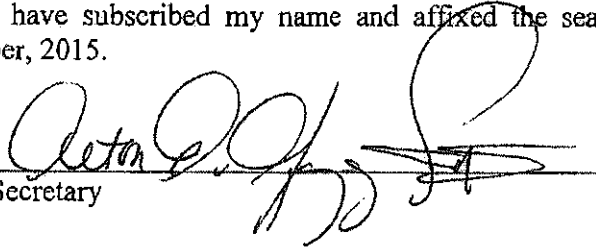
Secretary

Filed for Record in:
BRAZOS COUNTY

On: Nov 17, 2015 at 12:02P

As a
Recordings

Document Number: 01248904

Amount 346.00

Receipt Number - 560979

By:
Debbie Baker

STATE OF TEXAS COUNTY OF BRAZOS
I hereby certify that this instrument was
filed on the date and time stamped hereon by me
and was duly recorded in the volume and page
of the Official Public records of:

BRAZOS COUNTY

as stamped hereon by me.

Nov 17, 2015

Karen McQueen, Brazos County Clerk
BRAZOS COUNTY



**WATSON
LAW FIRM**

Joe Patranella

jpatranella@watsonlawyers.com

979.703.4044

December 29, 2015

Monica Longoria
Oakwood Custom Homes
4060 Highway 6 South
College Station, Texas 77845

Re: First Amendment to Declaration

Dear Monica:

Enclosed please find the recorded First Amendment to Declaration of Copper Creek Condos, a Condominium.

Please do not hesitate to call if you should have any questions.

Very truly yours,

WATSON LAW FIRM, L.L.P.



Joe R. Patranella

JRP:cpr
Our File #15-1077
Enclosure

**FIRST AMENDMENT TO
DECLARATION OF COPPER CREEK CONDOS,
A CONDOMINIUM**

THIS First Amendment to Declaration is made this 15th day of December, 2015, by River Ridge Townhomes, Ltd., a Texas limited partnership ("Declarant"), acted for herein by its General Partner, SKYCO Management, L.L.C., a Texas limited liability company, pursuant to the Texas Uniform Condominium Act, Chapter 82, Property Code of the State of Texas ("Act").

As per the provisions and rights contained in the "Declaration", as recorded in Volume 13045, Pages 165 through 245, Official Records of Brazos County, Texas, the Declaration is hereby amended as follows:

I. The amount of the Annual Assessment collected per unit per year shall hereby be One Hundred Sixty Five Dollars and No/100 Dollars (\$165.00). Section 6.4 of the Declaration, which governs the Annual Assessments of Copper Creek Condos, shall otherwise remain intact.

All other sections of the Declaration are to remain unaltered and functioning in full force and effect.

This Amendment shall be binding upon all property located within and subject to the Declaration.

WITNESS MY HAND effective as of the 30th day of November, 2015.

RIVER RIDGE TOWNHOMES, LTD.,
a Texas limited partnership

By: SKYCO MANAGEMENT, L.L.C.,
a Texas limited liability company,
its General Partner

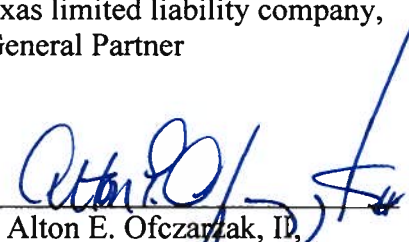
By: 
Alton E. Ofczarzak, II,
Managing Member

THE STATE OF TEXAS §

COUNTY OF BRAZOS §

I, Joe R. Patranella, a Notary Public, do hereby certify that Alton E. Ofczarzak, II, Managing Member of Skyco Management, L.L.C., a Texas limited liability company, acting in its capacity as General Partner of River Ridge Management, Ltd., a Texas limited partnership, personally appeared before me on this day and acknowledged the execution of the foregoing instrument.

WITNESS my hand and official seal on this 15th day of December, 2015.



Joe R. Patranella
Notary Public, State of Texas

Filed for Record in:
BRAZOS COUNTY

On: Dec 21, 2015 at 02:24P

As a
Recordings

Document Number: 01251440

Amount 30.00

Receipt Number - 563351

By:
Cathy Barcelona

STATE OF TEXAS COUNTY OF BRAZOS
I hereby certify that this instrument was
filed on the date and time stamped hereon by me
and was duly recorded in the volume and page
of the Official Public records of:

BRAZOS COUNTY

as stamped hereon by me.

Dec 21, 2015

Karen McQueen, Brazos County Clerk
BRAZOS COUNTY

**** Electronically Filed Document ****

**Brazos County, TX
Karen McQueen
County Clerk**

Document Number: 2016-1265660

Recorded As : ERX-RECORDINGS

Recorded On: June 02, 2016
Recorded At: 04:11:35 pm
Number of Pages: 7
Book-VI/Pg: Bk-OR VI-13385 Pg-78
Recording Fee: \$50.00

Parties:

Direct-
Indirect-

Receipt Number: 576044
Processed By: Becky Wright

***** THIS PAGE IS PART OF THE INSTRUMENT *****

Any provision herein which restricts the Sale, Rental or use of the described REAL PROPERTY because of color or race is invalid and unenforceable under federal law.



I hereby certify that this instrument was filed on the date and time stamped hereon by me and was duly recorded in the volume and page of the Official Public records of BRAZOS COUNTY, TEXAS

Honorable Karen McQueen, County Clerk, Brazos County

LAWYERS TITLE CO.
GF# 537252

#2

**CORRECTION TO FIRST AMENDMENT TO
DECLARATION OF COPPER CREEK CONDOS,
A CONDOMINIUM**

THIS Correction to First Amendment to Declaration is made this 26th day of August, 2016, by River Ridge Townhomes, Ltd., a Texas limited partnership ("Declarant"), acted for herein by its General Partner, SKYCO Management, L.L.C., a Texas limited liability company, pursuant to the Texas Uniform Condominium Act, Chapter 82, Property Code of the State of Texas ("Act").

As per the provisions and rights contained in the "Declaration", as recorded in Volume 13045, Pages 165 through 245, Official Records of Brazos County, Texas and the "First Amended Declaration", as recorded in Volume 13092, Pages 272 through 273, Official Records of Brazos County, Texas, the First Amended Declaration is hereby corrected to read as follows:

I. The amount of the Annual Assessment is One Thousand Nine Hundred Eighty Dollars and No/100 (\$1,980.00) and is to be collected per unit per month on a monthly basis of One Hundred Sixty Five Dollars and No/100 Dollars (\$165.00). Section 6.4 of the Declaration, which governs the Annual Assessments of Copper Creek Condos, shall otherwise remain intact.

This Correction is being made to accurately reflect that the abovementioned One Hundred Sixty Five Dollars and No/100 Dollars (\$165.00) payment amount is due on a monthly, not yearly, basis as to be in line with the payment scheme of the Annual Assessments of Copper Creek Condo mentioned above.

All other sections of the Declaration are to remain unaltered and functioning in full force and effect.

This Correction to Amendment shall be binding upon all property located within and subject to the Declaration.

WITNESS MY HAND to be effective as of the 30th day of November, 2015.

RIVER RIDGE TOWNHOMES, LTD.,
a Texas limited partnership

By: SKYCO MANAGEMENT, L.L.C.,
a Texas limited liability company,
its General Partner

By: 
Alton E. Ofdzarzak, II
Managing Member

STATE OF TEXAS
COUNTY OF BRAZOS

The foregoing is a true and correct copy as the same appears on file and recorded in the appropriate records of Brazos County, Texas

Thereby certify, on 08-20-2016 *mgpnc/a*





County Clerk,
Brazos County, Texas

THE STATE OF TEXAS §

COUNTY OF BRAZOS §

I, Jay Don Watson, a Notary Public, do hereby certify that Alton E. Ofczarzak, II, Managing Member of Skyco Management, L.L.C., a Texas limited liability company, acting in its capacity as General Partner of River Ridge Management, Ltd., a Texas limited partnership, personally appeared before me on this day and acknowledged the execution of the foregoing instrument.

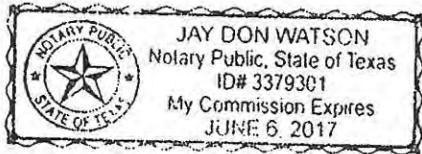
WITNESS my hand and official seal on this 26 day of August, 2016.



[Signature]
Notary Public, State of Texas

STATE OF TEXAS
COUNTY OF BRAZOS
The foregoing is a true and correct copy as the same appears on file and recorded in the appropriate records of Brazos County, Texas
Thereby certify, on 08-20-2016 Morgan



[Signature]
County Clerk,
Brazos County, Texas

**** Electronically Filed Document ****

**Brazos County, TX
Karen McQueen
County Clerk**

Document Number: 2016-1274492
Recorded As : ERX-RECORDINGS

Recorded On: August 26, 2016
Recorded At: 03:00:57 pm
Number of Pages: 3
Book-VI/Pg: Bk-OR VI-13568 Pg-120
Recording Fee: \$34.00

Parties:

Direct-
Indirect-

Receipt Number: 583126
Processed By: Becky Wright

***** THIS PAGE IS PART OF THE INSTRUMENT *****

Any provision herein which restricts the Sale, Rental or use of the described REAL PROPERTY because of color or race is invalid and unenforceable under federal law.



I hereby certify that this instrument was filed on the date and time stamped hereon by me and was duly recorded in the volume and page of the Official Public records of BRAZOS COUNTY, TEXAS

Honorable Karen McQueen, County Clerk, Brazos County

STATE OF TEXAS
COUNTY OF BRAZOS
The foregoing is a true and correct copy as the same appears on file and recorded in the appropriate records of Brazos County, Texas
Thereby certify, on 08-26-2016 Mgarcia

County Clerk,
Brazos County, Texas



**SECOND AMENDMENT TO
DECLARATION OF COPPER CREEK CONDOS,
A CONDOMINIUM**

THIS Second Amendment to Declaration is made this 1st day of June, 2016, by River Ridge Townhomes, Ltd., a Texas limited partnership ("Declarant"), acted for herein by its General Partner, SKYCO Management, L.L.C., a Texas limited liability company, pursuant to the Texas Uniform Condominium Act, Chapter 82, Property Code of the State of Texas ("Act").

As per the provisions and rights contained in the "Declaration", as recorded in Volume 13045, Pages 165 through 245, Official Records of Brazos County, Texas, and the "First Amended Declaration", as recorded in Volume 13092, Pages 272 through 273, Official Records of Brazos County, Texas, the Declaration and First Amendment are hereby amended as follows:

- I. As per the Declaration and the First Amended Declaration, the Condominium project, as shown and described in the Declaration and the First Amended Declaration, is hereby amended to include and add Phase II of the Additional Real Estate, as shown and described in the Declaration, and on and in the plats and documents attached thereto, and Phase II is hereby made a part of the Condominium, and Phase II is hereby subject to the terms, provisions and covenants of the Condominium and/or Declaration and the First Amendment for all purposes.
- II. Phase II is hereby made a part of the Condominium, and Phase II is hereby made subject to the terms, provisions and covenants of the Condominium and/or Declaration for all purposes.
- III. The building located in Phase II is Building "B", as shown on the drawing attached hereto as Exhibit "A". The Unit number for each Unit, the dimensions of each Unit, and the plan of each particular Unit in Building "B" are additionally described and set forth in Exhibit "A" attached hereto.
- IV. As per Section 3.7 of the Declaration, the percentage interest of each Unit Owner in the Condominium, in the Common Elements and Common Expenses after the addition of the seven (7) Units located in Phase II shall be in the ratios set forth on Exhibit "B" attached hereto and incorporated herein.
- V. Declarant retains the right to add all or any portion of the Additional Real Estate as defined in the Declaration to the Condominium as per the terms of the Declaration.

This Amendment shall be binding upon all property located within and subject to the Declaration.

WITNESS MY HAND effective as of the 1st day of June, 2016.

RIVER RIDGE TOWNHOMES, LTD.,
a Texas limited partnership

By: SKYCO MANAGEMENT, L.L.C.,
a Texas limited liability company,
its General Partner

By: 
Alton E. Ofczarzak, II, Managing Member

THE STATE OF TEXAS §

COUNTY OF BRAZOS §

I, Joe R. Patranella, a Notary Public, do hereby certify that Alton E. Ofczarzak, II, Managing Member of Skyco Management, L.L.C., a Texas limited liability company, acting in its capacity as General Partner of River Ridge Management, Ltd., a Texas limited partnership, personally appeared before me on this day and acknowledged the execution of the foregoing instrument.

WITNESS my hand and official seal on this 1st day of June, 2016.

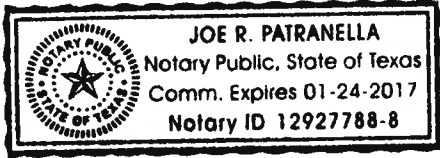

Joe R. Patranella
Notary Public, State of Texas

EXHIBIT "A"
TO
SECOND AMENDMENT TO DECLARATION OF COPPER CREEK CONDOS
PROPERTY, PLATS AND PLANS

LEGEND OF SYMBOLS:

SYMBOL LEGEND		LINE LEGEND	
	Manhole		Property Line
	Fire Hydrant		Tract/Lot Line
	Sign		Building Setback Line
	Clean-Out		Easement Line
	Light Pole		Overhead Electric Line
	Power Pole		Paving Line
	Gate Valve		Fence
	Water Meter		Edge of Pavement/Grove
	Transformer Box		
	Gate		



VICINITY MAP
(NOT TO SCALE)

Field Notes
Tract Two
6.33 Acres

Being all of that certain tract or parcel of land, lying and being situated in the CRAWFORD BURNETT LEAGUE, Abstract No. 7, College Station, Brazos County, Texas, and being all of lot 2R of William Brooke Hunter Estates according to the plat recorded in Volume 7627, page 19, of the Official Records of Brazos County, Texas, and being more particularly described as follows:

BEGINNING, at a 5/8" iron rod with cap set found at the most southerly common corner of this tract and lot 1R of said Subdivision and being in the northeasterly Right-of-Way line of Southwest Parkway, same being the beginning of a curve to the left;

THENCE, 39.27 feet around said curve to the left with a radius of 25.00 feet and whose chord bears N 09° 20' 35" E - 35.36 feet along the common line between this tract and said lot 1R to a 1/2" iron rod with cap (4502) found at the end of said curve;

THENCE, continuing along said common line between this tract and said lot 1R for the following calls:

S 35° 39' 25" E - 189.00 feet,
S 54° 20' 35" W - 29.87 feet and

S 35° 39' 25" E - 423.01 feet to a 5/8" iron rod with cap (4502) found for the most westerly common corner of this tract and lot 9, block 2 of the South-Land Addition recorded in (134423);

N 42° 33' 47" E - 551.28 feet along the common line between this tract and lots 9 through 20, block 2 of said South-Land Addition to a point for the most northerly common corner of this tract, lot 20 of said South-Land Addition and lot 1 of Parkway Circle recorded in (508561);

THENCE, along the common line between this tract and said lot 1 of Parkway Circle for the following calls:

S 54° 20' 35" W - 29.87 feet,
S 66° 37' 17" E - 36.34 feet,
N 09° 57' 46" W - 38.37 feet,
S 30° 10' 06" E - 33.63 feet,
S 09° 46' 36" E - 65.99 feet,
N 25° 50' 07" E - 31.91 feet,
N 01° 22' 52" E - 30.28 feet,
N 71° 17' 14" E - 28.00 feet,
L9
L10
L11
L12
L13
L14
L15
L16
L17
L18
L19
L20
L21

THENCE, S 17° 27' 19" E - 145.73 feet to a point for the most southeasterly common corner of the tract and said lot 1 of Parkway Circle, same being in said Right-of-Way line of Southwest Parkway;

THENCE, S 54° 20' 35" W - 229.80 feet along said Right-of-Way line of Southwest Parkway to the PLACE OF BEGINNING, and containing 6.33 acres of land, more or less, according to a survey made on the ground under the supervision of Donald Garrett, Registered Professional Land Surveyor, No. 2972 on July 24, 2015.

LINE	BEARING	DISTANCE
L1	S 54° 20' 35" W	29.87
L2	S 66° 37' 17" E	36.34
L3	N 09° 57' 46" W	38.37
L4	S 30° 10' 06" E	33.63
L5	S 09° 46' 36" E	65.99
L6	N 25° 50' 07" E	31.91
L7	N 01° 22' 52" E	30.28
L8	N 71° 17' 14" E	28.00
L9	S 20° 57' 19" E	50.21
L10	S 71° 42' 07" E	46.32
L11	S 29° 33' 57" E	26.07
L12	N 17° 24' 05" E	79.27
L13	N 02° 53' 48" E	81.73
L14	N 24° 17' 05" E	61.14
L15	S 17° 27' 19" E	145.73

- NOTES:
- This survey is invalid without the original signature and is only valid for this initial transaction.
 - Base-of-Bearing: Plat bearing used as Basis of Bearing.
 - Fence lines may not be exactly on property lines.
 - This Survey was prepared using without the benefit of a Title Company's Title Commitment.
 - Utility Note: The underground utilities shown have been located from field survey information and existing drawings. The surveyor makes no guarantee that the underground utilities shown comprise all such utilities in the area, either in service or abandoned. The surveyor further does not warrant that the underground utilities shown are in the exact location indicated although he does certify that they are located as accurately as possible from information at hand. The surveyor has not physically located the underground utilities.
 - The Property is Zoned PDD Planned Development District.
 - A Portion of this property is in the 100-year flood hazard area as established by the Federal Emergency Management Agency, Flood Firm Community Panel No. 4804100305, April 2, 2014.
 - 8 Parking, Standard Parking Spaces Required: 183
Standard Parking Spaces Provided: 193
Van Accessible Nonzero Parking Spaces Provided: 2
 - No monuments were set in place.

CURVE	RADIUS	DELTA	TANGENT	LENGTH CHD.	L.C.
C1	25.00'	90°00'00"	25.00'	39.27'	N 09° 20' 35" E 35.36'

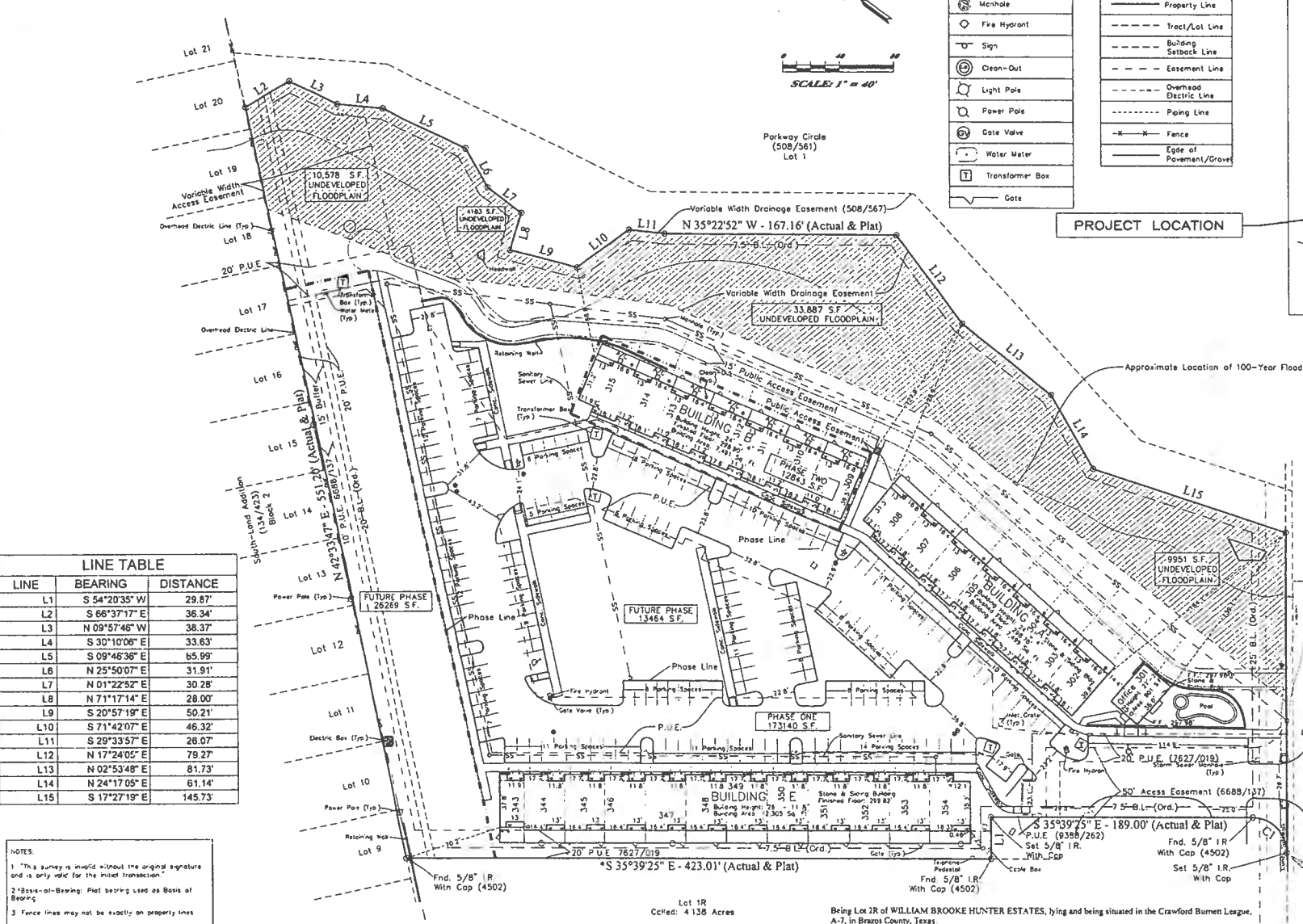
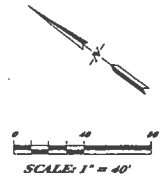

Being Lot 2R of WILLIAM BROOKE HUNTER ESTATES, lying and being situated in the Crawford Burnett League, A-7, in Brazos County, Texas.

The undersigned further hereby certifies to said parties as of the 24th day of July, 2015, that the survey conforms to the 2011 Minimum Standard Detail Requirements for ALTA/ACSM Land Title Surveys, jointly established and adopted by ALTA and NPS, and includes items 1-5, 7(c), 7(e), 8, 9, 10(a), 10(b), 11(b), 13-19, 20(a) of Table A thereof. The field work was completed on August 10, 2015.

I, Donald Garrett, GARRETT ENGINEERING CONSULTING ENGINEERING & LAND SURVEYING, a registered land surveyor, do hereby certify to the CITY OF COLLEGE STATION, Brazos County, Texas, that this instrument is a true and correct survey made on the ground under my supervision.

I further certify that no improvements on this property encroach on adjacent property nor do any improvements on adjacent property encroach on this property, except as shown.

Donald Garrett
Registered Professional Land Surveyor No. 2972

ALTA/ACSM LAND TITLE SURVEY
OF
LOT 2R (6.33 Acres)
(Amended to add Building "B" - Phase Two)
WILLIAM BROOKE HUNTER ESTATES
CRAWFORD BURNETT LEAGUE, ABSTRACT NO. 7
301 SOUTHWEST PARKWAY
COLLEGE STATION, BRAZOS COUNTY TEXAS

GARRETT ENGINEERING
Consulting Engineering & Land Surveying
4144 Carter Creek Parkway Suite 100
Bryan, Texas 77802
Telephone: (877) 466-2888
Fax: (979) 848-3084

EXHIBIT "B"
TO
SECOND AMENDMENT TO DECLARATION OF COPPER CREEK CONDOS
PERCENT INTEREST CHART

<u>Bldg. No.</u>	<u>Unit No. On Plans</u>	<u>Percent Interest</u>
A	302	3.8967%
A	303	3.8967%
A	304	3.8967%
A	305	3.8967%
A	306	3.8967%
A	307	3.8967%
A	308	3.8967%
E	343	2.5829 %
E	344	3.8967%
E	345	3.8967%
E	346	3.8967%
E	347	3.8967%
E	348	3.8967%
E	349	3.8967%
E	350	3.8967%
E	351	3.8967%
E	352	3.8967%
E	353	3.8967%
E	354	3.8967%
B	309	3.8967%
B	310	3.8967%
B	311	3.8967%
B	312	3.8967%
B	313	3.8967%
B	314	3.8967%
B	315	3.8967%

**** Electronically Filed Document ****

**Brazos County, TX
Karen McQueen
County Clerk**

**Document Number: 2016-1273313
Recorded As : ERX-RECORDINGS**

**Recorded On: August 15, 2016
Recorded At: 02:55:44 pm
Number of Pages: 10
Book-VI/Pg: Bk-OR VI-13544 Pg-149
Recording Fee: \$62.00**

Parties:

**Direct-
Indirect-**

**Receipt Number: 582136
Processed By: Patsy Montalbano**

***** THIS PAGE IS PART OF THE INSTRUMENT *****

Any provision herein which restricts the Sale, Rental or use of the described REAL PROPERTY because of color or race is invalid and unenforceable under federal law.

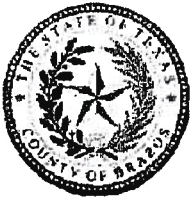

I hereby certify that this instrument was filed on the date and time stamped hereon by me and was duly recorded in the volume and page of the Official Public records of BRAZOS COUNTY, TEXAS

Honorable Karen McQueen, County Clerk, Brazos County

**THIRD AMENDMENT TO
DECLARATION OF COPPER CREEK CONDOS,
A CONDOMINIUM**

THIS Third Amendment to Declaration is made this 15th day of August, 2016, by River Ridge Townhomes, Ltd., a Texas limited partnership ("Declarant"), acted for herein by its General Partner, SKYCO Management, L.L.C., a Texas limited liability company, pursuant to the Texas Uniform Condominium Act, Chapter 82, Property Code of the State of Texas ("Act").

As per the provisions and rights contained in the "Declaration", as recorded in Volume 13045, Page 165, Official Records of Brazos County, Texas, the "First Amended Declaration", as recorded in Volume 13092, Page 272, Official Records of Brazos County, Texas, and the "Second Amended Declaration", as recorded in Volume 13385, Page 78, the Declaration, First Amended Declaration, and Second Amended Declaration are hereby amended as follows:

- I. As per the Declaration, the First Amended Declaration, and the Second Amended Declaration, the Condominium project, as shown and described in the Declaration, the First Amended Declaration, and the Second Amended Declaration, is hereby amended to include and add Phase III of the Additional Real Estate, as shown and described in the Declaration, and on and in the plats and documents attached thereto, Phase III is hereby made a part of the Condominium, and Phase III is hereby subject to the terms, provisions and covenants of the Condominium and/or Declaration, the First Amended Declaration and the Second Amended Declaration for all purposes.
- II. Phase III is hereby made a part of the Condominium, and Phase III is hereby made subject to the terms, provisions and covenants of the Condominium and/or Declaration for all purposes.
- III. The buildings located in Phase III are Building "C", Building "D", Building "F" and Building "G", as shown on the drawing attached hereto as Exhibit "A". The Unit number for each Unit, the dimensions of each Unit, and the plan of each particular Unit for the previously mentioned Buildings are additionally described and set forth in Exhibit "A" attached hereto.
- IV. As per Section 3.7 of the Declaration, the percentage interest of each Unit Owner in the Condominium, in the Common Elements and Common Expenses after the addition of the twenty-seven (27) Units located in Phase III shall be in the ratios set forth on Exhibit "B" attached hereto and incorporated herein.
- V. Declarant retains the right to add all or any portion of the Additional Real Estate as defined in the Declaration to the Condominium as per the terms of the Declaration.

This Amendment shall be binding upon all property located within and subject to the Declaration.

WITNESS MY HAND effective as of the 15th day of August, 2016.

RIVER RIDGE TOWNHOMES, LTD.,
a Texas limited partnership

By: SKYCO MANAGEMENT, L.L.C.,
a Texas limited liability company,
its General Partner

By: 
Alton E. Ofczarzak, II, Managing Member

THE STATE OF TEXAS §

COUNTY OF BRAZOS §

I, Joe R. Patranella, a Notary Public, do hereby certify that Alton E. Ofczarzak, II, Managing Member of Skyco Management, L.L.C., a Texas limited liability company, acting in its capacity as General Partner of River Ridge Management, Ltd., a Texas limited partnership, personally appeared before me on this day and acknowledged the execution of the foregoing instrument.

WITNESS my hand and official seal on this 15th day of August, 2016.

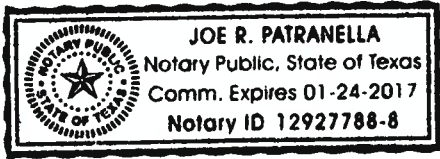

Joe R. Patranella
Notary Public, State of Texas

EXHIBIT "A"
TO
THIRD AMENDMENT TO DECLARATION OF COPPER CREEK CONDOS
PROPERTY, PLATS AND PLANS

tabbles
1044
A
EXHIBIT

LEGEND OF SYMBOLS:

SYMBOLS LEGEND		LINE LEGEND	
	Manhole		Property Line
	Fire Hydrant		Tract/Lot Line
	Sign		Building Setback Line
	Clean-Out		Easement Line
	Light Pole		Overhead Electric Line
	Power Pole		Piping Line
	Gate Valve		Fence
	Water Meter		Edge of Pavement/Driveway
	Transformer Box		
	Gate		

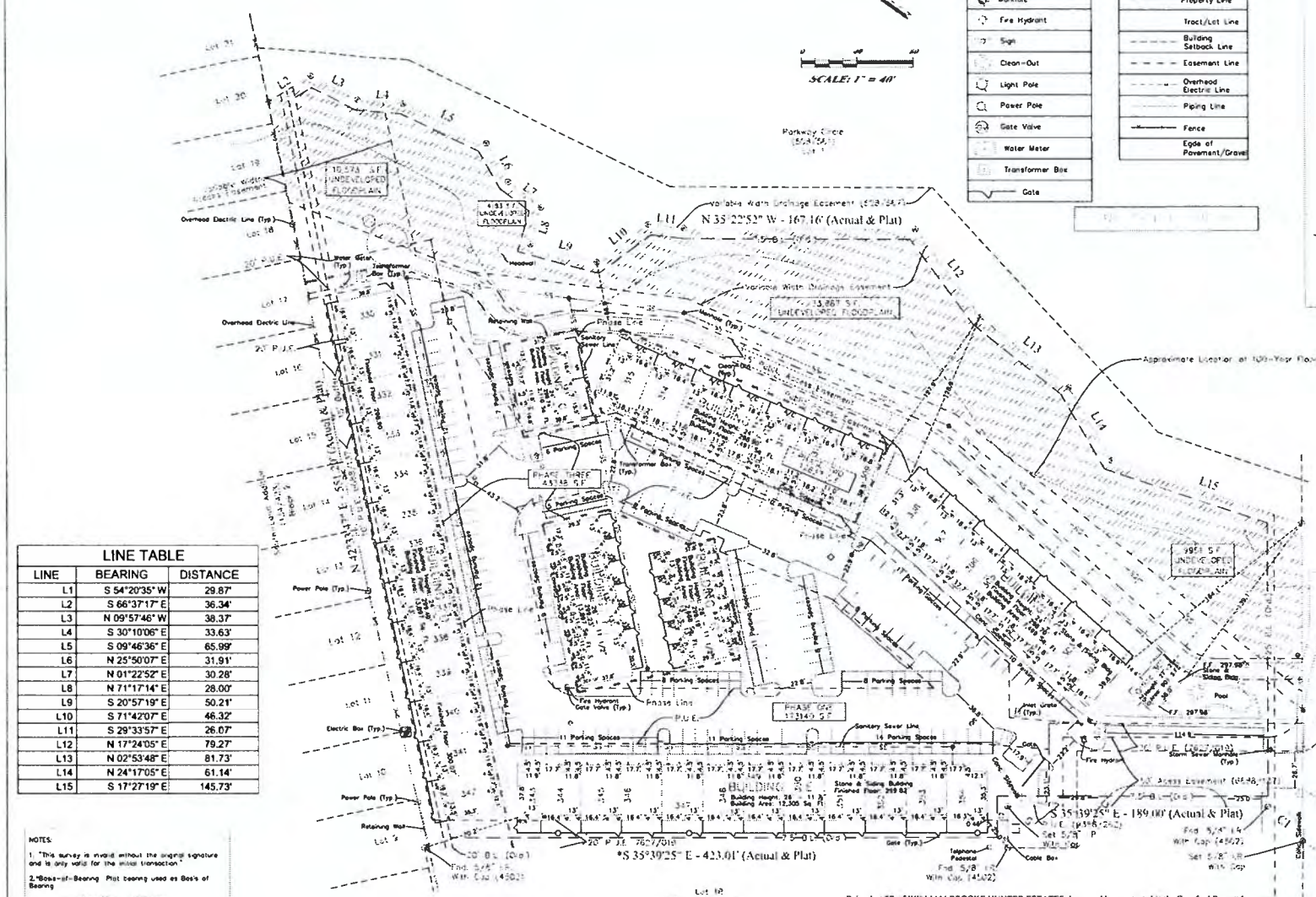
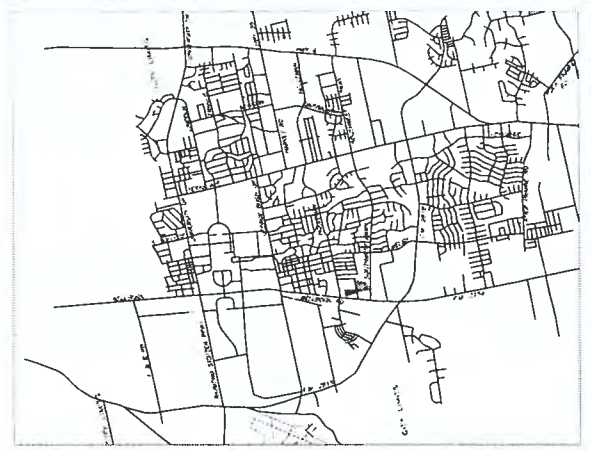

LINE TABLE

LINE	BEARING	DISTANCE
L1	S 54°20'35" W	29.87'
L2	S 66°37'17" E	36.34'
L3	N 09°57'46" W	38.37'
L4	S 30°10'06" E	33.63'
L5	S 09°46'36" E	65.99'
L6	N 25°50'07" E	31.91'
L7	N 01°22'52" E	30.28'
L8	N 71°17'14" E	28.00'
L9	S 20°57'19" E	50.21'
L10	S 71°42'07" E	46.32'
L11	S 29°33'57" E	26.07'
L12	N 17°24'05" E	79.27'
L13	N 02°53'48" E	81.73'
L14	N 24°17'05" E	61.14'
L15	S 17°27'19" E	145.73'

NOTES:

- This survey is invalid without the original signature and is only valid for the initial transaction.
- Beas-if-Bearing Plat bearing used as Basis of Bearing.
- Fence lines may not be exactly on property lines.
- This Survey was prepared using without the benefit of a Title Company's Title Commitment.
- Utility Note: The underground utilities shown have been located from field survey information and existing drawings. The surveyor makes no guarantee that the underground utilities shown compare to such utilities in the area, either in service or otherwise. The surveyor further does not warrant that the underground utilities shown are in the exact location indicated although he does certify that they are located as accurately as possible from information available. The surveyor has not physically located the underground utilities.
- The Property is Zoned: PDD Planned Development District.
- A Portion of the property is in the 100-year flood hazard area as established by the Federal Emergency Management Agency, Flood Firm Community Panel No. 4804(C0305), April 2, 2014.
- Parking: Standard Parking Spaces Provided: 193; Standard Parking Spaces Provided: 193; Non-Accessible Handicap Parking Spaces Provided: 2.
- No monuments were set in area.

Revised: December 16, 2015

CURVE TABLE

CURVE	RADIUS	DELTA	TANGENT	LENGTH	CHD.	L.C.
C1	25.00'	90°00'00"	25.00'	39.27'	N 09°20'35" E	35.36'

Being Lot 2R of WILLIAM BROOKE HUNTER ESTATES, lying and being situated in the Crawford Burnett League, A-7, in Brazos County, Texas.

The undersigned further hereby certifies to said parties as of the 24th day of July, 2015 that the survey conforms to the 2011 Minimum Standard Detail Requirements for ALTA/ACSM Land Title Surveys, jointly established and adopted by ALTA and NSPS, and includes items 1-3, 7(a), 7(c), 8, 9, 10(a), 10(b), 11(b), 13-19, 20(a) of Table A thereof. The field work was completed on August 10, 2015.

I, Donald Garrett, GARRETT ENGINEERING CONSULTING ENGINEERS & LAND SURVEYING, a registered land surveyor, do hereby certify to the CITY OF COLLEGE STATION, Brazos County, Texas, that this instrument is a true and correct survey made on the ground under my supervision.

I further certify that no improvements on this property encroach on adjacent property nor do any improvements on adjacent property encroach on this property, except as shown.

Donald Garrett,
Registered Professional Land Surveyor No. 2972

(NOT TO SCALE)

Field Notes
Tract Two
6.33 Acres

Being all of that certain tract or parcel of land, lying and being situated in the CRAWFORD BURNETT LEAGUE, Abstract No. 7, College Station, Brazos County, Texas and being all of lot 2R of William Brooke Hunter Estates according to the plat recorded in Volume 7627, page 19, of the Official Records of Brazos County, Texas and being more particularly described as follows:

BEGINNING: at a 5/8" iron rod with cap set found at the most southerly common corner of this tract and lot 1R of said Sub-division and being in the northeasterly Right-of-Way line of Southwest Parkway; same being the beginning of a curve to the left;

THENCE: 39.27 feet around said curve to the left with a radius of 25.00 feet and whose chord bears N 09° 20' 35" E - 35.36 feet, along the common line between this tract and said lot 1R to a 1/2" iron rod with cap (4502) found at the end of said curve.

THENCE: continuing along said common line between this tract and said lot 1R for the following calls:

S 35° 39' 25" E - 189.00 feet
S 54° 20' 35" W - 29.87 feet and

S 35° 39' 25" E - 423.01 feet to a 5/8" iron rod with cap (4502) found for the most easterly common corner of this tract and lot 9, block 2 of the South-Land Addition recorded in (134423);

N 42° 33' 47" E - 551.20 feet along the common line between this tract and lots 9 through 20, block 2 of said South-Land Addition to a point for the most northerly common corner of this tract, lot 20 of said South-Land Addition and lot 1 of Parkway Circle recorded in (500681);

THENCE: along the common line between this tract and said lot 1 of Parkway Circle for the following calls:

S 54° 20' 35" W - 29.87 feet,
S 66° 37' 17" E - 36.34 feet,
N 09° 57' 46" W - 38.37 feet,
S 30° 10' 06" E - 33.63 feet,
S 09° 46' 36" E - 65.99 feet,
N 25° 50' 07" E - 31.91 feet,
N 01° 22' 52" E - 30.28 feet,
N 71° 17' 14" E - 28.00 feet,
S 20° 57' 19" E - 50.21 feet,
S 71° 42' 07" E - 46.32 feet,
S 29° 33' 57" E - 26.07 feet,
N 17° 24' 05" E - 79.27 feet,
N 02° 53' 48" E - 81.73 feet,
N 24° 17' 05" E - 61.14 feet and

THENCE: S 17° 27' 19" E - 145.73 feet, to a point for the most southeasterly common corner of the tract and said lot 1 of Parkway Circle; same being in said Right-of-Way line of Southwest Parkway;

THENCE: S 54° 20' 35" W - 229.80 feet along said Right-of-Way line of Southwest Parkway to the PLACE OF BEGINNING; and containing 6.33 acres of land, more or less, according to a survey made on the ground under the supervision of Donald Garrett, Registered Professional Land Surveyor, No. 2972 on July 24, 2015.

301 Southwest Parkway
P.O.B.

ALTA/ACSM LAND TITLE SURVEY
OF
LOT 2R (6.33 Acres)
(Amended to add Buildings "C", "D", "F" & "G" - Phase Three)
WILLIAM BROOKE HUNTER ESTATES
CRAWFORD BURNETT LEAGUE, ABSTRACT NO. 7
301 SOUTHWEST PARKWAY
COLLEGE STATION, BRAZOS COUNTY TEXAS

GARRETT ENGINEERING
Consulting Engineering & Land Surveying
4444 Carter Creek Parkway Suite 100
College Station, Texas 77805
Telephone (979) 848 - 2888
Fax (979) 848 - 3094

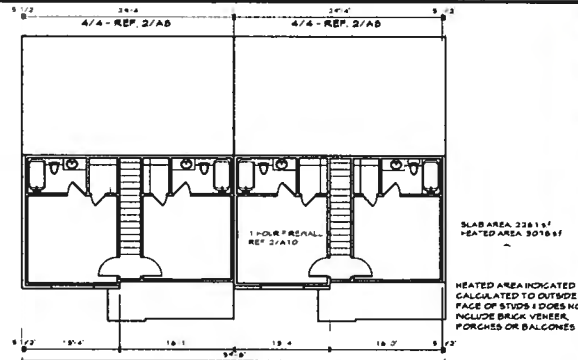

4 BLDG. C - 2nd FLOOR PLAN

PHASE 3

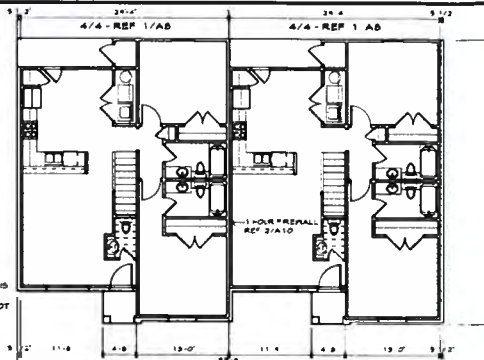

3 BLDG. C - 1st FLOOR PLAN

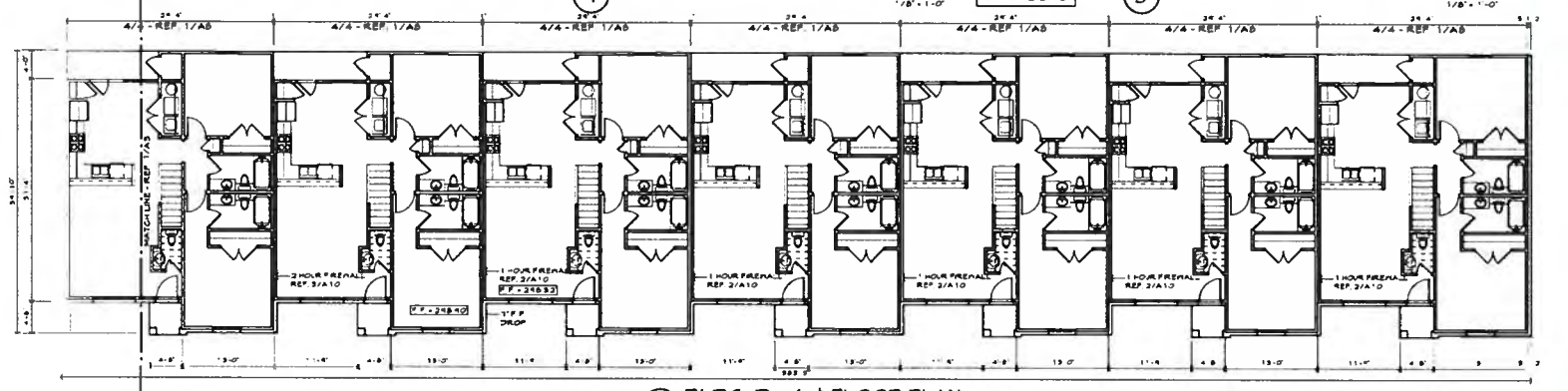

2 BLDG. D - 1st FLOOR PLAN (RIGHT)

PHASE 3

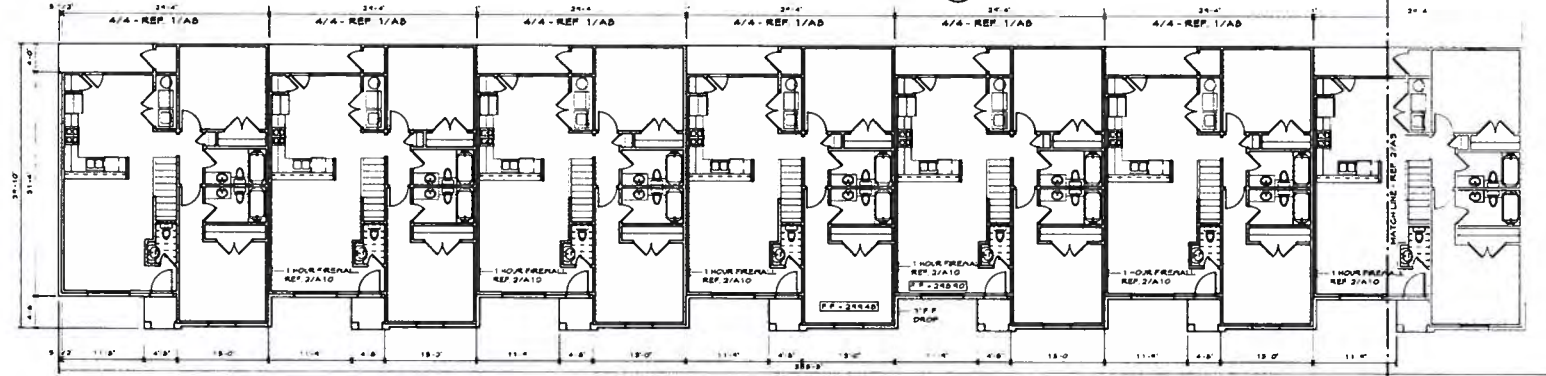

1 BLDG. D - 1st FLOOR PLAN (LEFT)

PHASE 3

tabbles
EXHIBIT
A
2 of 4



COPPER CREEK CONDOS
COLLEGE STATION TEXAS
Transition Design Service
201 W Villa Maria Road • Bryan, Texas 77801 • (979) 822-7777

DATE AUG 2014

A3

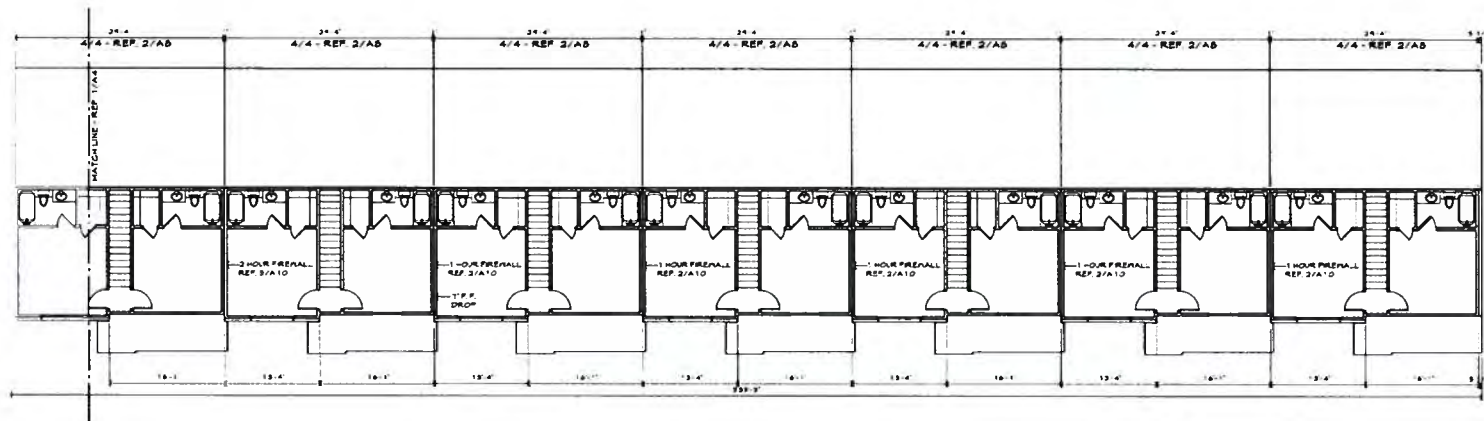

2 BLDG. D - 2nd FLOOR PLAN (RIGHT) PHASE 3
1/8" = 1'-0"

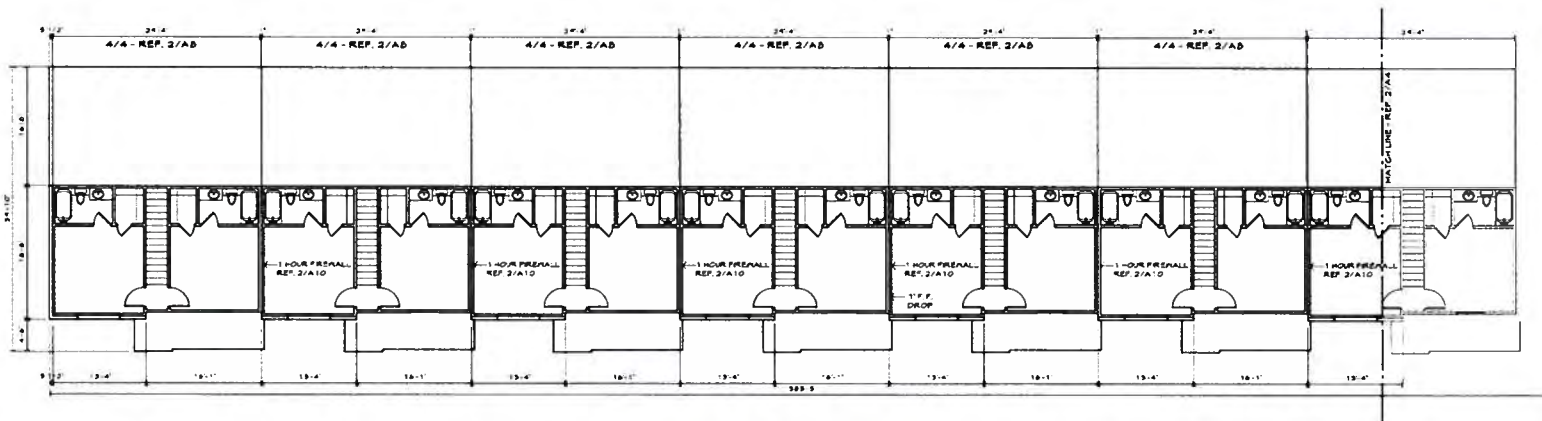

1 BLDG. D - 2nd FLOOR PLAN (LEFT) PHASE 3
1/8" = 1'-0"

tabbles'
EXHIBIT
A
3 of 4



COPPER CREEK CONDOS
COLLEGE STATION TEXAS
Transition Design Service
201 W Villa Maria Road • Bryan, Texas 77801 • (979) 822-7777

DATE AUG 2016

A4

tabbles
EXHIBIT
A
4 of 4

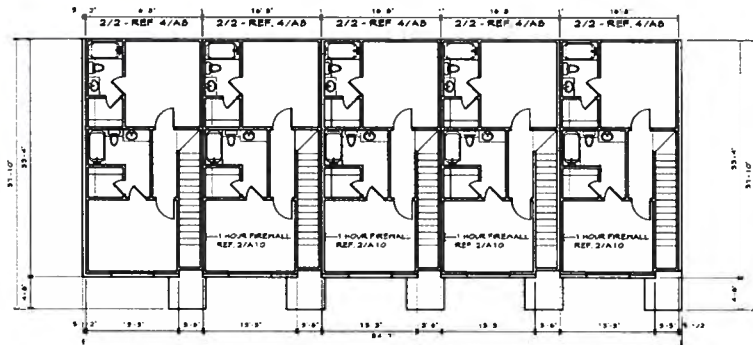

④ BLDG. G - 2nd FLOOR PLAN PHASE 3
1/8" = 1'-0"

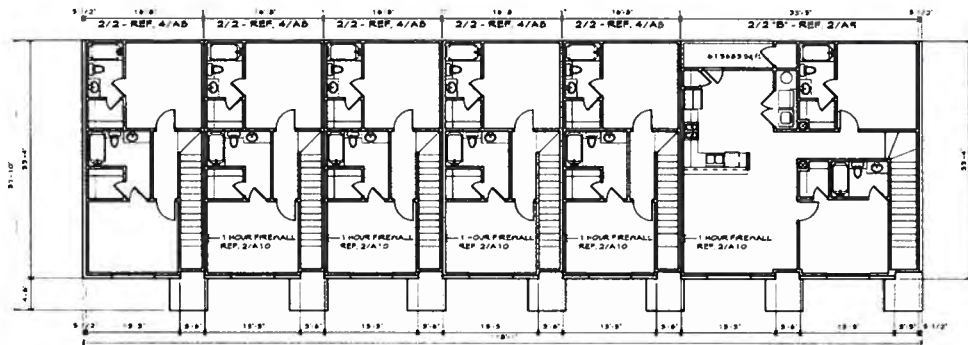

② BLDG. F - 2nd FLOOR PLAN PHASE 3
1/8" = 1'-0"

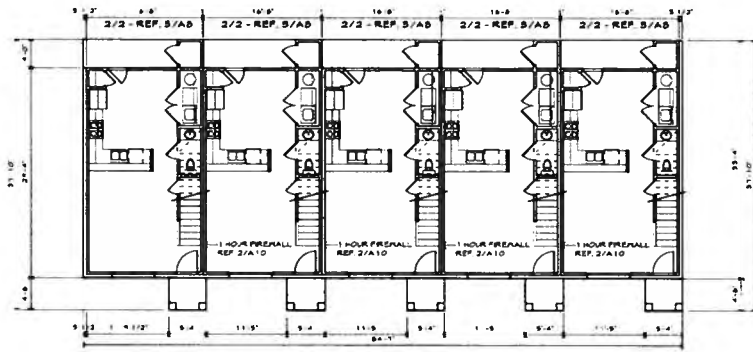

③ BLDG. G - 1st FLOOR PLAN PHASE 3
1/8" = 1'-0"

SLAB AREA 3894 SF
HEATED AREA 3158 SF

HEATED AREA INDICATED IS CALCULATED TO OUTSIDE FACE OF STUDS. IT DOES NOT INCLUDE BRICK VENEER, PORCHES OR BALCONIES.

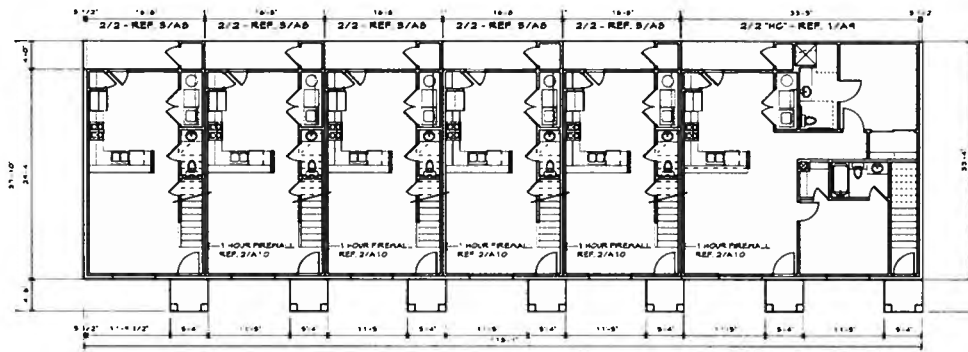

① BLDG. F - 1st FLOOR PLAN PHASE 3
1/8" = 1'-0"

SLAB AREA 4063 SF
HEATED AREA 3515 SF

HEATED AREA INDICATED IS CALCULATED TO OUTSIDE FACE OF STUDS. IT DOES NOT INCLUDE BRICK VENEER, PORCHES OR BALCONIES.



COPPER CREEK CONDOS
COLLEGE STATION TEXAS
Transition Design Service
201 W. Villa Maria Road • Bryan, Texas 77801 • (979) 822-7777

DATE AUG 2016

A7

EXHIBIT "B"
TO
THIRD AMENDMENT TO DECLARATION OF COPPER CREEK CONDOS
PERCENT INTEREST CHART

<u>Bldg. No.</u>	<u>Unit No. On Plans</u>	<u>Percent Interest</u>
A	302	2.0569%
A	303	2.0569%
A	304	2.0569%
A	305	2.0569%
A	306	2.0569%
A	307	2.0569%
A	308	2.0569%
E	343	1.3634%
E	344	2.0569%
E	345	2.0569%
E	346	2.0569%
E	347	2.0569%
E	348	2.0569%
E	349	2.0569%
E	350	2.0569%
E	351	2.0569%
E	352	2.0569%
E	353	2.0569%
E	354	2.0569%
B	309	2.0569%
B	310	2.0569%
B	311	2.0569%
B	312	2.0569%
B	313	2.0569%
B	314	2.0569%
B	315	2.0569%
C	316	2.0569%
C	317	2.0569%
D	330	2.0569%
D	331	2.0569%
D	332	2.0569%
D	333	2.0569%
D	334	2.0569%
D	335	2.0569%
D	336	2.0569%
D	337	2.0569%
D	338	2.0569%
D	339	2.0569%
D	340	2.0569%
D	341	2.0569%

D	342	2.0569%
F	318	1.3634%
F	319	1.3634%
F	320	1.3634%
F	321	1.3634%
F	322	1.3634%
F	323	1.3634%
F	324	1.3634%
G	325	1.3634%
G	326	1.3634%
G	327	1.3634%
G	328	1.3634%
G	329	1.3634%

Addendum

Copper Creek Condos HOA approve the contract to enter into contract with SuddenLink to purchase internet and cable for the units at Copper Creek Condos the amount per unit of 65.00 per unit. The total dues will include the in the total amount of 165.00 per month.

Approved  Date 12/1/15
President

LAWYERS TITLE CO.
GF# 537221

#5

**FOURTH AMENDMENT TO
DECLARATION OF COPPER CREEK CONDOS,
A CONDOMINIUM**

THIS Fourth Amendment to Declaration is made this 3rd day of August, 2016, by River Ridge Townhomes, Ltd., a Texas limited partnership ("Declarant"), acted for herein by its General Partner, SKYCO Management, L.L.C., a Texas limited liability company, pursuant to the Texas Uniform Condominium Act, Chapter 82, Property Code of the State of Texas ("Act").

As per the provisions and rights contained in the "Declaration", as recorded in Volume 13045, Page 165, Official Records of Brazos County, Texas, the "First Amended Declaration", as recorded in Volume 13092, Page 272, Official Records of Brazos County, Texas, the "Corrected First Amended Declaration", as recorded in Volume 13568, Page 120, Official Records of Brazos County, Texas, "Second Amended Declaration", as recorded in Volume 13385, Page 78, and the "Third Amended Declaration", as recorded in Volume 13544, Page 149, Official Records of Brazos County, Texas, the Declaration, First Amended Declaration, Corrected First Amended Declaration, Second Amended Declaration, and Third Amended Declaration are hereby amended as follows:

I. The amount of the Annual Assessment collected per unit per month shall hereby be One Hundred Ninety Dollars and No/100 Dollars (\$190.00). Section 6.4 of the Declaration, which governs the Annual Assessments of Copper Creek Condos, shall otherwise remain intact.

All other sections of the Declaration are to remain unaltered and functioning in full force and effect.

This Amendment shall be binding upon all property located within and subject to the Declaration.

This Amendment shall be effective as of the 30th day of November, 2015.

WITNESS MY HAND on this the 31st day of August, 2016.

RIVER RIDGE TOWNHOMES, LTD.,
a Texas limited partnership

By: SKYCO MANAGEMENT, L.L.C.,
a Texas limited liability company,
its General Partner

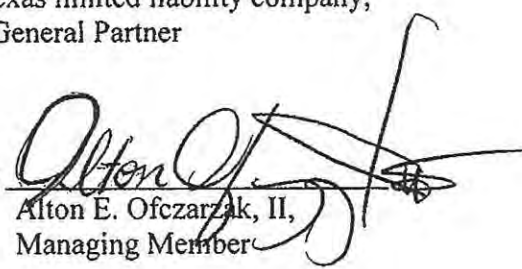
By: 
Alton E. Ofczarzak, II,
Managing Member

STATE OF TEXAS
COUNTY OF BRAZOS

The foregoing is a true and correct copy as the same appears on file an recorded in the appropriate records of Brazos County, Texas

Thereby certify, on 08-20-2021 Ngahera





County Clerk,
Brazos County, Texas

THE STATE OF TEXAS §

COUNTY OF BRAZOS §

I, Joe R. Patranella, a Notary Public, do hereby certify that Alton E. Ofczarzak, II, Managing Member of Skyco Management, L.L.C., a Texas limited liability company, acting in its capacity as General Partner of River Ridge Management, Ltd., a Texas limited partnership, personally appeared before me on this day and acknowledged the execution of the foregoing instrument.

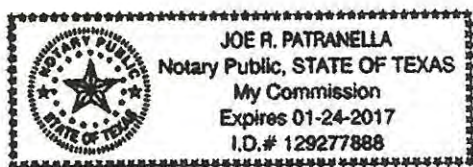
WITNESS my hand and official seal on this 31st day of August, 2016.



Joe R. Patranella
Notary Public, State of Texas

STATE OF TEXAS
COUNTY OF BRAZOS
The foregoing is a true and correct copy as the same appears on file an recorded in the appropriate records of Brazos County, Texas
Thereby certify, on 08-20-2016 Ngareira
 Anna McQueen
County Clerk,
Brazos County, Texas

**** Electronically Filed Document ****

**Brazos County, TX
Karen McQueen
County Clerk**

**Document Number: 2016-1275046
Recorded As : ERX-RECORDINGS**

**Recorded On: August 31, 2016
Recorded At: 03:20:17 pm
Number of Pages: 3
Book-VI/Pg: Bk-OR VI-13578 Pg-106
Recording Fee: \$34.00**

Parties:

**Direct-
Indirect-**

**Receipt Number: 583525
Processed By: Becky Wright**

***** THIS PAGE IS PART OF THE INSTRUMENT *****

Any provision herein which restricts the Sale, Rental or use of the described REAL PROPERTY because of color or race is invalid and unenforceable under federal law.



I hereby certify that this instrument was filed on the date and time stamped hereon by me and was duly recorded in the volume and page of the Official Public records of BRAZOS COUNTY, TEXAS

Honorable Karen McQueen, County Clerk, Brazos County

STATE OF TEXAS
COUNTY OF BRAZOS

The foregoing is a true and correct copy as the same appears on file and recorded in the appropriate records of Brazos County, Texas

Thereby certify, on 08-20-2021 *Karen McQueen*



Karen McQueen
County Clerk,
Brazos County, Texas

**FIRST AMENDMENT TO
BY-LAWS OF COPPER CREEK CONDOS HOA**

WHEREFORE, the By-Laws of the Copper Creek Condos HOA, dated November 16, 2015 and recorded in Volume 13045, Page 220 of the Official Records of Brazos County, Texas inadvertently asserted that the name of the Association is Copper Creek Condos HOA, Inc.

The name of the Association is Copper Creek Condos HOA, as provided in that certain Certificate of Filing granted by the Office of the Secretary of State of Texas, File Number 802163875; Document 591725190002.

THEREFORE, Article 1. Section 1.1 of the By-Laws of Copper Creek Condos HOA, dated November 16, 2015 and recorded in Volume 13045, Page 220 of the Official Records of Brazos County, Texas are hereby amended to assert that the name of the Association is Copper Creek Condos HOA.

FURTHER, all other references to Copper Creek Condos HOA, Inc., within the afore-described By-Laws, shall be amended to Copper Creek Condos HOA.

All other terms and conditions of the By-Laws dated November 16, 2015 and recorded in Volume 13045, Page 220 of the Official Records of Brazos County, Texas remain in full force and effect.

Dated the 30th day of May, 2018.

COPPER CREEK CONDOS HOA

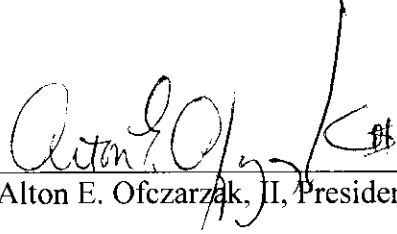
By:  _____
Alton E. Ofczarzak, II, President

STATE OF TEXAS

COUNTY OF BRAZOS

This instrument was acknowledged before me on the 30th day of May, 2018 by Alton E. Ofczarzak, II, President of COPPER CREEK CONDOS HOA on behalf of said corporation and in the capacity therein stated.

Angela Kay Morris
Notary Public, State of Texas

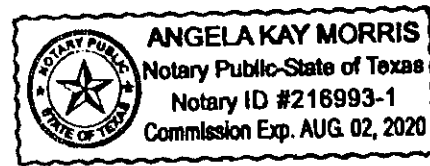

Prepared in the Law Office of:
Watson Law Firm, L.L.P.
1450 Copperfield Pkwy, Ste. 300
College Station, Texas 77845

AKM 15-1077/COPPER CREEK CONDOS/Amendment To By-Laws

Brazos County
Karen McQueen
County Clerk

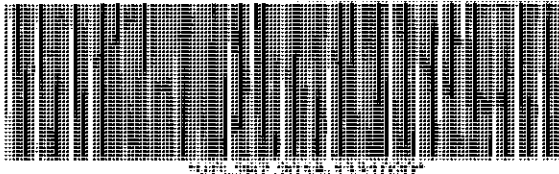

Instrument Number: 1331020
Volume : 14706
Real Property Recordings

Recorded On: June 04, 2018 01:38 PM

Number of Pages: 3

" Examined and Charged as Follows: "

Total Recording: \$30.00

******* THIS PAGE IS PART OF THE INSTRUMENT *******

Any provision herein which restricts the Sale, Rental or use of the described REAL PROPERTY because of color or race is invalid and unenforceable under federal law.

File Information:

Document Number: 1331020
Receipt Number: 20180604000107
Recorded Date/Time: June 04, 2018 01:38 PM
User: Patsy D
Station: CCLERK05

Record and Return To:

WATSON LAW FIRM
1450 COPPERFIELD PKWY SUITE 300
COLLEGE STATION TX 77845

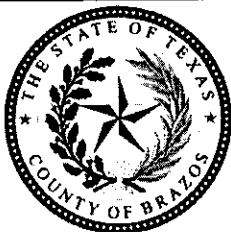

STATE OF TEXAS
COUNTY OF BRAZOS

I hereby certify that this Instrument was FILED in the File Number sequence on the date/time printed hereon, and was duly RECORDED in the Official Public Records of Brazos County, Texas.

Karen McQueen
County Clerk
Brazos County, TX