

**ADDRESS: 3611 LANERCOST LANE**

PLAT NO. 2023055132

MFE: 154.45'

AREA: 6,381 S.F. ~ 0.15 ACRES

DRAINAGE TYPE: "A"

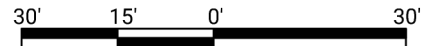

GRAPHIC SCALE: 1" = 30'

<b>TOTAL FENCE</b>	169 LF
FRONT	13 LF
LEFT	50 LF
RIGHT	55 LF
REAR	51 LF
<b>AREAS</b>	
LOT AREA	6,381 SF
SLAB	1,954 SF
LOT COVERAGE	31 %
INTURN	176 SF
DRIVEWAY	435 SF
PUBLIC WALK	170 SF
PRIVATE WALK	44 SF
REAR YARD AREA	278.4 SY
FRONT YARD AREA	171.1 SY

**OPTIONS:**  
 NO BRICK,  
 COVERED PATIO, FRAMING,  
 FOUNDATION & ROOF RAFTER  
 DETAILS

Line	Bearing	Distance
L1	S 26°22'26" W	11.99'

Curve	Radius	Length	Chord	Chord Bearing
C1	50.0'	52.35'	49.99'	N 25°30'27" E

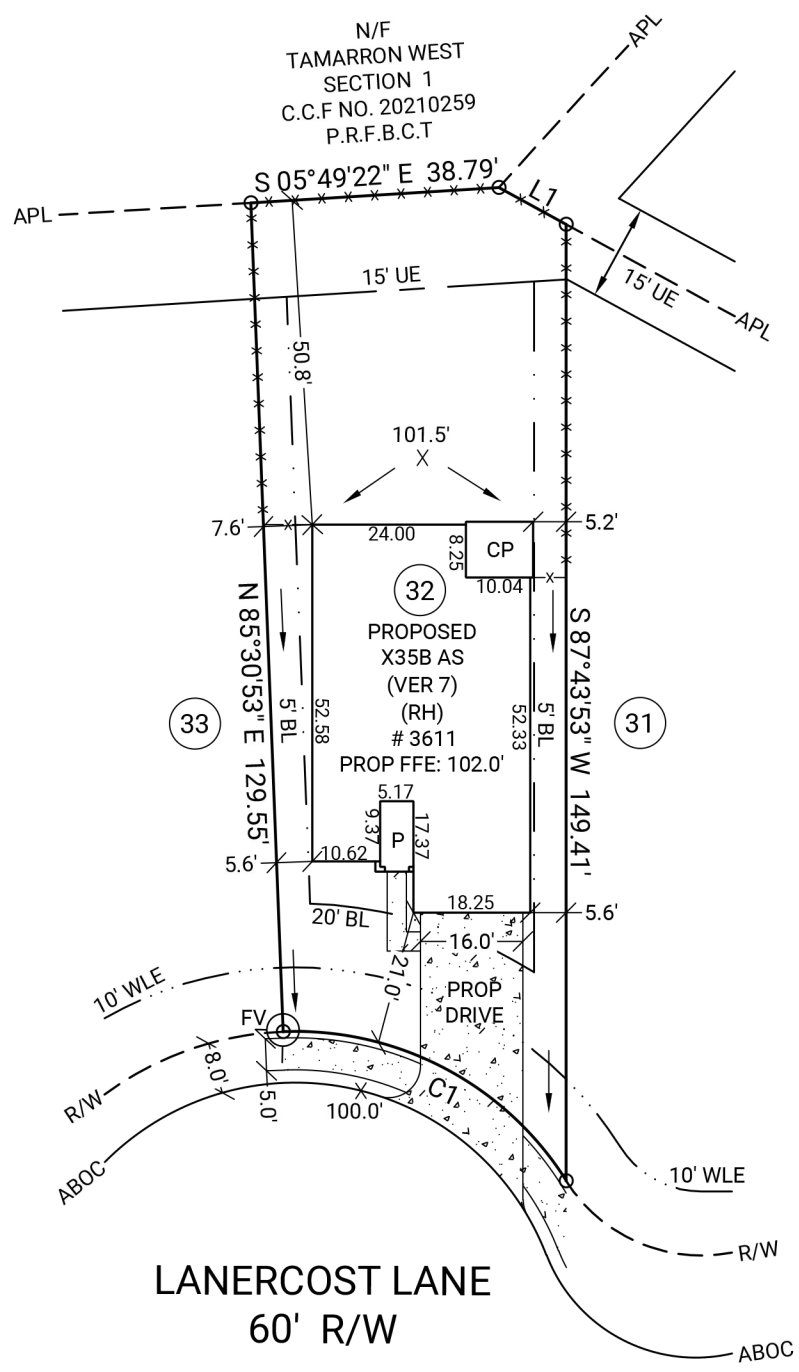
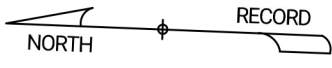

- LEGEND**
- BL Building Line
  - APL Approximate Property Line
  - ABOC Approximate Back of Curb
  - R/W Right of Way
  - N/F Now or Formerly
  - UE Utility Easement
  - DE Drainage Easement
  - SSE Sanitary Sewer Easement
  - WLE Water Line Easement
  - STMSE Storm Sewer Easement
  - PROP Proposed
  - MFE Minimum Finished Floor Elevation
  - FFE Finished Floor Elevation
  - GFE Garage Floor Elevation
  - P Porch
  - CP Covered Patio
  - PAT Patio
  - FV Flush Valve
  - CONC Concrete
  - X- Fence
  - TOF Top of Forms
  - RBF Rebar Found
  - RBS Rebar Set

NOTE: BASE ELEVATION IS ASSUMED.  
 (FOR REFERENCE ONLY)  
 NOTE: PLOT PLAN PREPARED WITHOUT BENEFIT OF TITLE.

**GENERAL NOTES:** No field work has been performed. This property is subject to additional easements or restrictions of record. Carter & Clark Surveyors is unable to warrant the accuracy of boundary information, structures, easements, and buffers that are illustrated on the subdivision plat. Utility easement has not been field verified by surveyor. contact utility contractor for location prior to construction (if applicable). This plat is for exclusive use by client. Use by third parties is at their own risk. Dimensions from house to property lines should not be used to establish fences. City sidewalks, driveway approaches, and other improvements inside the city's right of way are provided for demonstration purposes only. consult the development plans for actual construction. This plat has been calculated for closure and is found to be accurate within one foot in 10,000+ feet.