

## TEXAS OFFICIAL WOOD DESTROYING INSECT REPORT

Rule 57.176 Requires this department prescribed form to be used for real estate transactions in Texas regarding the visible presence or absence of wood destroying insects and conditions conducive to infestations of wood destroying insects.

2755 Longleaf Pines Ln

Inspected Address

Humble

City

77339

Zip Code

### SCOPE OF INSPECTION

- A. This inspection covers only the multi-family structure, primary dwelling or place of business. Sheds, detached garages, lean-tos, fences, guest houses or any other structure will not be included in this inspection report unless specifically noted in Section 5 of this report.
- B. This inspection is limited to those parts of the structure(s) that are visible and accessible at the time of the inspection. Examples of inaccessible areas include but are not limited to (1) areas concealed by wall coverings, furniture, equipment and stored articles and (2) any portion of the structure in which inspection would necessitate removing or defacing any part of the structure(s) (including the surface appearance of the structure). **Inspection does not cover any condition or damage which was not visible in or on the structure(s) at time of inspection but which may be revealed in the course of repair or replacement work.**
- C. Due to the characteristics and behavior of various wood destroying insects, it may not always be possible to determine the presence of infestation without defacing or removing parts of the structure being inspected. Previous damage to trim, wall surface, etc., is frequently repaired prior to the inspection with putty, spackling, tape or other decorative devices. Damage that has been concealed or repaired may not be visible except by defacing the surface appearance. **The WDI inspecting company cannot guarantee or determine that work performed by a previous pest control company, as indicated by visual evidence of previous treatment; has rendered the pest(s) inactive.**
- D. If visible evidence of active or previous infestation of listed wood destroying insects is reported, it should be assumed that some degree of damage is present.
- E. If visible evidence is reported, it does not imply that damage should be repaired or replaced. Inspectors of the inspection company usually are not engineers or builders qualified to give an opinion regarding the degree of structural damage. Evaluation of damage and any corrective action should be performed by a qualified expert.
- F. **THIS IS NOT A STRUCTURAL DAMAGE REPORT OR A WARRANTY AS TO THE ABSENCE OF WOOD DESTROYING INSECTS.**
- G. If termite treatment (including pesticides, baits or other methods) has been recommended, the treating company must provide a diagram of the structure(s) inspected and proposed for treatment, label of pesticides to be used and complete details of warranty (if any). The warranty should specify which areas of the structure(s) are covered by warranty, renewal options and approval by a certified applicator in the termite category. Information regarding treatment and any warranties should be provided by the party contracting for such services to any prospective buyers of the property. The inspecting company has no duty to provide such information to any person other than the contracting party.
- H. There are a variety of termite control options offered by pest control companies. These options will vary in cost, efficacy, areas treated, warranties, treatment techniques and renewal options.
- I. There are some specific guidelines as to when it is appropriate for corrective treatment to be recommended. Corrective treatment may only be recommended if (1) there is visible evidence of an active infestation in or on the structure, (2) there is visible evidence of a previous infestation with no evidence of a prior treatment.
- J. If treatment is recommended based solely on the presence of conducive conditions, a preventive treatment or correction of conducive conditions may be recommended. The buyer and seller should be aware that there may be a variety of different strategies to correct the conducive condition(s). These corrective measures can vary greatly in cost and effectiveness and may or may not require the services of a licensed pest control operator. There may be instances where the inspector will recommend correction of the conducive conditions by either mechanical alteration or cultural changes. Mechanical alteration may be in some instances the most economical method to correct conducive conditions. If this inspection report recommends any type of treatment and you have any questions about this, you may contact the inspector involved, another licensed pest control operator for a second opinion, and/or the Structural Pest Control Service of the Texas Department of Agriculture.

2755 Longleaf Pines Ln

Humble

77339

Inspected Address

City

Zip Code

1A. Green Team Pest 1B. 0759610
Name of Inspection Company SPCS Business License Number

1C. 2341 S San Antonio St Ste 100 Pearland TX 77581 (281) 295-1633
Address of Inspection Company City State Zip Telephone No.

1D. Gonzales Dowdell 1E. Certified Applicator [ ] (check one)
Name of Inspector (Please Print) Technician [X]
1F. 07/08/2023
Inspection Date

2. Tristan Hair Seller [ ] Agent [X] Buyer [X] Management Co. [ ] Other [ ] N/A
Name of Person Purchasing Inspection

3. Owner of Record
Owner/Seller

4. REPORT FORWARDED TO: Title Company or Mortgagee [ ] Purchaser of Service [ ] Seller [ ] Agent [X] Buyer [X]
(Under the Structural Pest Control regulations only the purchaser of the service is required to receive a copy)

The structure(s) listed below were inspected in accordance with the official inspection procedures adopted by the Texas Department of Agriculture Structural Pest Control Service. This report is made subject to the conditions listed under the Scope of Inspection. A diagram must be attached including all structures inspected.

5A. Residence
List structure(s) inspected that may include residence, detached garages and other structures on the property. (Refer to Part A, Scope of Inspection)

5B. Type of Construction:
Foundation: Slab [X] Pier & Beam [ ] Pier Type: N/A Basement [ ] Other [ ] N/A
Siding: Wood [ ] Fiber Cement Board [ ] Brick [X] Stone [ ] Stucco [ ] Other [ ] N/A
Roof: Composition [X] Wood Shingle [ ] Metal [ ] Tile [ ] Other [ ] N/A

6A. This company has treated or is treating the structure for the following wood destroying insects: N/A
If treating for subterranean termites, the treatment was: Partial [ ] Spot [ ] Bait [ ] Other [ ]
If treating for drywood termites or related insects, the treatment was: Full [ ] Limited [ ]

6B. N/A N/A N/A
Date of Treatment by Inspecting Company Common Name of Insect Name of Pesticide, Bait or Other Method

This company has a contract or warranty in effect for control of the following wood destroying insects:
Yes [ ] No [X] List Insects: N/A
If "Yes", copy(ies) of warranty and treatment diagram must be attached.

Neither I nor the company for which I am acting have had, presently have, or contemplate having any interest in the purchase or sale of this property. I do further state that neither I nor the company for which I am acting is associated in any way with any party to this real estate transaction.

Signatures:
7A. TDA #832846
Inspector (Technician or Certified Applicator Name and License Number)

Others Present:
7B. N/A
Apprentices, Technicians, or Certified Applicators Name(s) and Registration/License Number(s)

Notice of Inspection Was Posted At or Near:

8A. Electric Breaker Box [ ] 8B. Date Posted: 07/08/2023
Water Heater Closet [ ]
Beneath the Kitchen Sink [X]

9A. Were any areas of the property obstructed or inaccessible? Yes [X] No [ ]
(Refer to Part B & C, Scope of Inspection) If "Yes" specify in 9B.

9B. The obstructed or inaccessible areas include but are not limited to the following:
Attic [ ] Insulated area of attic [X] Plumbing Areas [X] Planter box abutting structure [ ]
Deck [X] Sub Floors [ ] Slab Joints [X] Crawl Space [ ]
Soil Grade Too High [X] Heavy Foliage [X] Eaves [X] Weepholes [X]
Other [X] Specify: Bath Traps, Patio Brick/Tile, Furniture/Storage, Shear Crack, Fresh Paint, Un-decked areas of the attic

10A. Conditions conducive to wood destroying insect infestation: Yes [X] No [ ]
(Refer to Part J, Scope of Inspection) If "Yes" specify in 10B.

10B. Conducive Conditions include but are not limited to:
Wood to Ground Contact (G) [X] Formboards left in place (I) [ ] Excessive Moisture (J) [ ]
Debris under or around structure (K) [ ] Footing too low or soil line too high (L) [X] Wood Rot (M) [X] Heavy Foliage (N) [X]
Planter box abutting structure (O) [ ] Wood Pile in Contact with Structure (Q) [ ] Wooden Fence in Contact with the Structure (R) [ ]
Insufficient ventilation (T) [ ] Other (C) [ ] Specify: N/A

2755 Longleaf Pines Ln

Humble

77339

Inspected Address

City

Zip Code

11. Inspection Reveals Visible Evidence in or on the structure:

- 11A. Subterranean Termites
- 11B. Drywood Termites
- 11C. Formosan Termites
- 11D. Carpenter Ants
- 11E. Other Wood Destroying Insects

Active Infestation

- Yes  No
- Yes  No
- Yes  No
- Yes  No
- Yes  No

Previous Infestation

- Yes  No
- Yes  No
- Yes  No
- Yes  No
- Yes  No

Previous Treatment

- Yes  No
- Yes  No
- Yes  No
- Yes  No
- Yes  No

Specify: N/A

11F. Explanation of signs of previous treatment (including pesticides, baits, existing treatment stickers or other methods) identified:

N/A

11G. Visible evidence of: N/A has been observed in the following areas: N/A

If there is visible evidence of active or previous infestation, it must be noted. The type of insect(s) must be listed in the first blank and all identified infested areas of the property inspected must be noted in the second blank. (Refer to Part D, E & F, Scope of Inspection)

12A. Corrective treatment recommended for active infestation or evidence of previous infestation with no prior treatment as identified in Section 11. (Refer to Part G, H, and I, Scope of Inspection) Yes  No

12B. A preventive treatment and/or correction of conducive conditions as identified in 10A & 10B is recommended as follows: Yes  No

Specify reason: Appropriate treatment -or-, Lower Soil (show 2-3" of slab), Replace rotted areas, Remove foliage at least 6" away, Alter wood contact with home, And follow up inspection by a qualified pest control professional

Refer to Scope of Inspection Part J

### Diagram of Structure(s) Inspected

The inspector must draw a diagram including approximate perimeter measurements and indicate active or previous infestation and type of insect by using the following codes: E-Evidence of Infestation, A-Active; P-Previous; D-Drywood Termites; S-Subterranean Termites; F-Formosan Termites; C-Conducive Conditions; B-Wood Boring Beetles; H-Carpenter Ants; Other(s) - Specify N/A

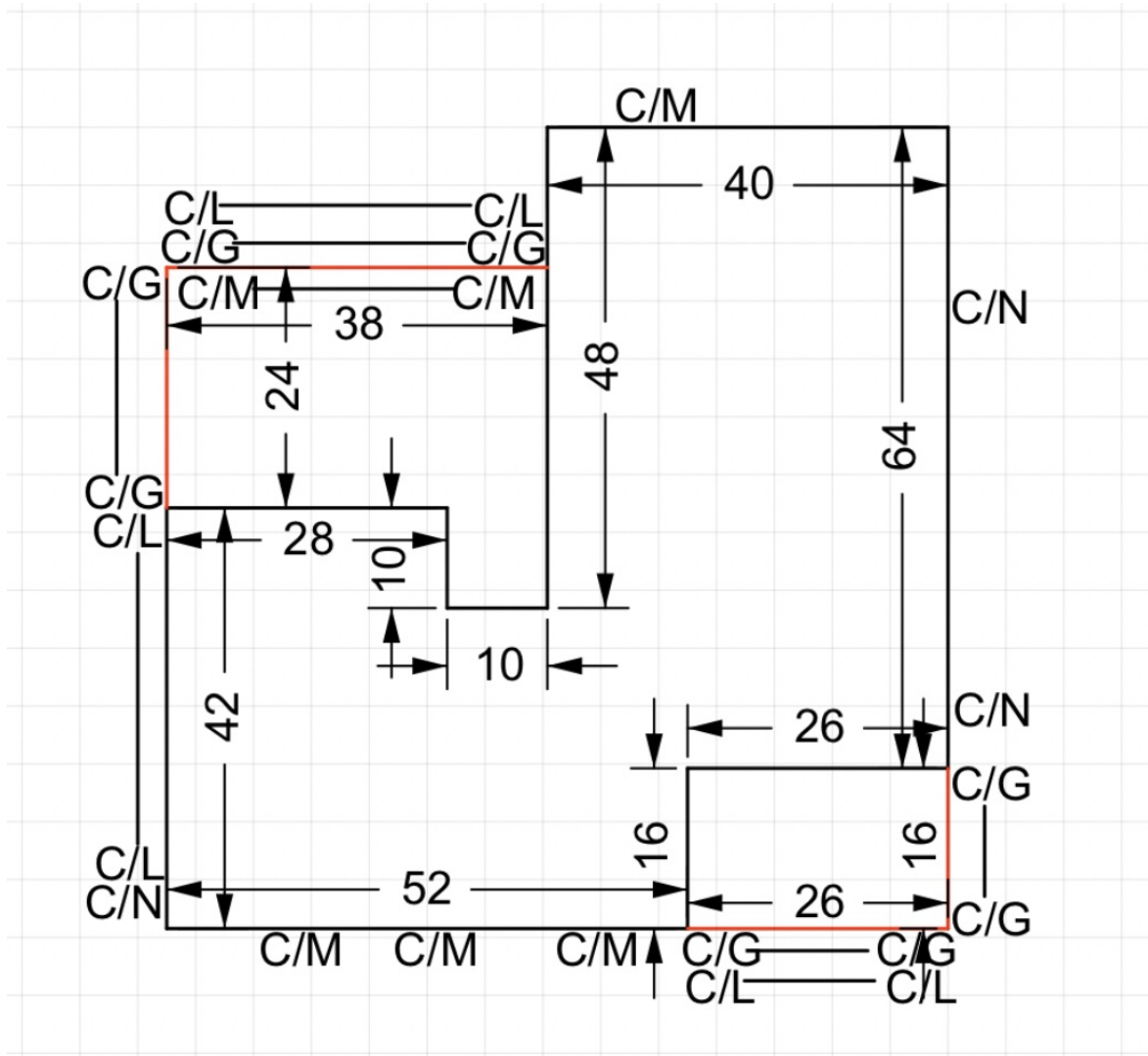

Additional Comments Order# 58641 | Drawing not to scale.

**2755 Longleaf Pines Ln**

Inspected Address

**Humble**

City

**77339**

Zip Code

**Statement of Purchaser**

I have received the original or a legible copy of this form. I have read and understand any recommendations made. I have also read and understand the "Scope of Inspection." I understand that my inspector may provide additional information as an addendum to this report.

If additional information is attached, list number of pages: \_\_\_\_\_

Signature of Purchaser of Property or their Designee

Date

Customer or Designee Not present

**Buyer's Initials** \_\_\_\_\_