



HEDDERMAN SERVICES

281-355-9911

office@hedderman.com

<https://hedderman.com/>



MECHANICAL INSPECTION

4920 Laurel Street
Bellaire Tx 77401



Inspector

Eddy Rodriguez

Engineer & TREC#23614

281-355-9911

office@hedderman.com



PROPERTY INSPECTION REPORT

Prepared For: Austin Stuckert & Michael Smaglick
(Name of Clients)

Concerning: 4920 Laurel Street , Bellaire Tx 77401
(Address or Other Identification of Inspected Property)

By: Eddy Rodriguez - Engineer & TREC#23614 07/13/2021 9:00 am
(Name and License Number of Inspector) (Date)

PURPOSE, LIMITATIONS AND INSPECTOR / CLIENT RESPONSIBILITIES

This property inspection report may include an inspection agreement (contract), addenda, and other information related to property conditions. If any item or comment is unclear, you should ask the inspector to clarify the findings. It is important that you carefully read ALL of this information.

This inspection is subject to the rules ("Rules") of the Texas Real Estate Commission ("TREC"), which can be found at www.trec.texas.gov.

The TREC Standards of Practice (Sections 535.227-535.233 of the Rules) are the minimum standards for inspections by TREC-licensed inspectors. An inspection addresses only those components and conditions that are present, visible, and accessible at the time of the inspection. While there may be other parts, components or systems present, only those items specifically noted as being inspected were inspected. The inspector is NOT required to turn on decommissioned equipment, systems, utility services or apply an open flame or light a pilot to operate any appliance. The inspector is NOT required to climb over obstacles, move furnishings or stored items. The inspection report may address issues that are code-based or may refer to a particular code; however, this is NOT a code compliance inspection and does NOT verify compliance with manufacturer's installation instructions. The inspection does NOT imply insurability or warrantability of the structure or its components. Although some safety issues may be addressed in this report, this inspection is NOT a safety/code inspection, and the inspector is NOT required to identify all potential hazards.

In this report, the inspector shall indicate, by checking the appropriate boxes on the form, whether each item was inspected, not inspected, not present or deficient and explain the findings in the corresponding section in the body of the report form. The inspector must check the Deficient (D) box if a condition exists that adversely and materially affects the performance of a system or component or constitutes a hazard to life, limb or property as specified by the TREC Standards of Practice. General deficiencies include inoperability, material distress, water penetration, damage, deterioration, missing components, and unsuitable installation. Comments may be provided by the inspector whether or not an item is deemed deficient. The inspector is not required to prioritize or emphasize the importance of one deficiency over another.

Some items reported may be considered life-safety upgrades to the property. For more information, refer to Texas Real Estate Consumer Notice Concerning Recognized Hazards or Deficiencies below.

THIS PROPERTY INSPECTION IS NOT A TECHNICALLY EXHAUSTIVE INSPECTION OF THE STRUCTURE, SYSTEMS OR COMPONENTS. This inspection may not reveal all deficiencies. A real estate inspection helps to reduce some of the risk involved in purchasing a home, but it cannot eliminate these risks, nor can the inspection anticipate future events or changes in performance due to changes in use or occupancy. It is recommended that you obtain as much information as is available about this property, including seller's disclosures, previous inspection reports, engineering reports, building/remodeling permits, and reports performed for and by relocation companies, municipal inspection departments, lenders, insurers, and appraisers. You should also attempt to determine whether repairs, renovation, remodeling, additions, or other such activities have taken place at this property. It is not the inspector's responsibility to confirm that information obtained from these sources is complete or accurate or that this inspection is consistent with the opinions expressed in previous or future reports.

ITEMS IDENTIFIED IN THE REPORT DO NOT OBLIGATE ANY PARTY TO MAKE REPAIRS OR TAKE OTHER ACTIONS, NOR IS THE PURCHASER REQUIRED TO REQUEST THAT THE SELLER TAKE ANY ACTION. When a deficiency is reported, it is the client's responsibility to obtain further evaluations and/or cost estimates from qualified service professionals. Any such follow-up should take place prior to the expiration of any time limitations such as option periods.

Evaluations by qualified tradesmen may lead to the discovery of additional deficiencies which may involve additional repair costs. Failure to address deficiencies or comments noted in this report may lead to further damage of the structure or systems and add to the original repair costs. The inspector is not required to provide follow-up services to verify that proper repairs have been made.

Property conditions change with time and use. For example, mechanical devices can fail at any time, plumbing gaskets and seals may crack if the appliance or plumbing fixture is not used often, roof leaks can occur at any time regardless of the apparent condition of the roof, and the performance of the structure and the systems may change due to changes in use or occupancy, effects of weather, etc. These changes or repairs made to the structure after the inspection may render information contained herein obsolete or invalid. This report is provided for the specific benefit of the client named above and is based on observations at the time of the inspection. If you did not hire the inspector yourself, reliance on this report may provide incomplete or outdated information. Repairs, professional opinions or additional inspection reports may affect the meaning of the information in this report. It is recommended that you hire a licensed inspector to perform an inspection to meet your specific needs and to provide you with current information concerning this property.

TEXAS REAL ESTATE CONSUMER NOTICE CONCERNING HAZARDS OR DEFICIENCIES

Each year, Texans sustain property damage and are injured by accidents in the home. While some accidents may not be avoidable, many other accidents, injuries, and deaths may be avoided through the identification and repair of certain hazardous conditions. Examples of such hazards include:

- malfunctioning, improperly installed, or missing ground fault circuit protection (GFCI) devices for electrical receptacles in garages, bathrooms, kitchens, and exterior areas;
- malfunctioning arc fault protection (AFCI) devices;
- ordinary glass in locations where modern construction techniques call for safety glass;
- malfunctioning or lack of fire safety features such as smoke alarms, fire-rated doors in certain locations, and functional emergency escape and rescue openings in bedrooms;
- malfunctioning carbon monoxide alarms;
- excessive spacing between balusters on stairways and porches;
- improperly installed appliances;
- improperly installed or defective safety devices;
- lack of electrical bonding and grounding; and
- lack of bonding on gas piping, including corrugated stainless steel tubing (CSST).

To ensure that consumers are informed of hazards such as these, the Texas Real Estate Commission (TREC) has adopted Standards of Practice requiring licensed inspectors to report these conditions as "Deficient" when performing an inspection for a buyer or seller, if they can be reasonably determined.

These conditions may not have violated building codes or common practices at the time of the construction of the home, or they may have been "grandfathered" because they were present prior to the adoption of codes prohibiting such conditions. While the TREC Standards of Practice do not require inspectors to perform a code compliance inspection, TREC considers the potential for injury or property loss from the hazards addressed in the Standards of Practice to be significant enough to warrant this notice.

Contract forms developed by TREC for use by its real estate license holders also inform the buyer of the right to have the home inspected and can provide an option clause permitting the buyer to terminate the contract within a specified time. Neither the Standards of Practice nor the TREC contract forms require a seller to remedy conditions revealed by an inspection. The decision to correct a hazard or any deficiency identified in an inspection report is left to the parties to the contract for the sale or purchase of the home.

INFORMATION INCLUDED UNDER "ADDITIONAL INFORMATION PROVIDED BY INSPECTOR", OR PROVIDED AS AN ATTACHMENT WITH THE STANDARD FORM, IS NOT REQUIRED BY THE COMMISSION AND MAY CONTAIN CONTRACTUAL TERMS BETWEEN THE INSPECTOR AND YOU, AS THE CLIENT. THE COMMISSION DOES NOT REGULATE CONTRACTUAL TERMS BETWEEN PARTIES. IF YOU DO NOT UNDERSTAND THE EFFECT OF ANY CONTRACTUAL TERM CONTAINED IN THIS SECTION OR ANY ATTACHMENTS, CONSULT AN ATTORNEY.

ADDITIONAL INFORMATION PROVIDED BY INSPECTOR

Hedderman Engineering Inc.:

>It is the purpose of this report to give our client my educated and experienced opinion of the condition and function of the stated property as visually inspected by Hedderman Engineering Inc. The inspection performed on this property is of a general nature and includes the following systems: electrical, mechanical, and plumbing. This does not include any specialized inspections and/or inspections of any hazardous materials (such as done in environmental inspections) or any of the following; structural systems, mold, audio/visual components, hazardous materials and gases, rated walls, lead paint, destructive insects or pest, security items, water or air treatment systems, etc. This inspection is limited to those components which were visible and accessible at the time of the inspection. It is noted that this report contains the opinions of this inspector of the stated property as it appeared on the day of the inspection and is in no way a warranty of any component in the days and future following the inspection. All mechanical components are judged on the basis of age, condition, and the function of those items as they appeared on the day of the inspection and are not guaranteed to

continue functioning in that manner in the future. It is recommended that the our client purchase a home warranty policy to protect oneself from both unexpected and anticipated problems that may occur in the future.

>It is noted that Hedderman Engineering Inc. is not responsible for any problems found in the house during or after components are opened up, disassembled, uncovered, made visible, or made accessible by another entity after the inspection is completed.

>If a builder or service contractor examines an area of question and comes to the conclusion that there is no repair needed, have them present to you in writing that the item is in compliance with a prevailing code and is functioning properly, not in need of repair.

>It is the intent of this inspector to work in compliance with the Standards Of Practice For Real Estate Inspectors. It is not required of this company to exceed these standards. You may obtain a copy of the document referred to above by contacting the Texas Real Estate Commission. It is also noted that this inspection is not a "code inspection", but rather an inspection of the condition and function of the stated property.

>Although this report may include observations of some building code violations, total compliance with mechanical, plumbing, electrical codes, specifications, and/or legal requirements are specifically excluded. We do not perform "code" inspections, and since building codes change every few years, our inspections are not performed with the intention of bringing every item in the property into compliance with current code requirements. Rather, the standard of our inspections is a performance standard to determine if the items inspected are functioning at the time of the inspection, or are in need of repair. This is particularly applicable to Home Warranty policies, where the standards of the Home Warranty service company are often different than our stated performance standard for judging whether a piece of equipment is functional or in need of repair. If you intend to rely on a Home Warranty policy, then it is recommended that you contact the appropriate service companies for a more in-depth analysis of what may be required to meet their standards should a claim be made against the policy.

>If there are any questions or concerns please contact Hedderman Engineering, Inc. at 281-355-9911 or Office@HeddermanEngineering.com.

I. STRUCTURAL SYSTEMS

A. Foundation

Comments:

B. Grading and Drainage

Comments:

C. Roof Covering Materials

Comments:

D. Roof Structures & Attics

Comments:

E. Walls (Interior and Exterior)

Comments:

F. Ceilings and Floors

Comments:

G. Doors (Interior and Exterior)

Comments:

H. Windows

Comments:

I. Stairways (Interior and Exterior)

Comments:

J. Fireplaces and Chimneys

Comments:

K. Porches, Balconies, Decks and Carports

Comments:

The structural portions of this property were inspected by an engineer from Hedderman Engineering Inc. per the inspection agreement between this firm and our client. All comments regarding the structure and property grade are found in the structure report that is created and provided by the engineers at Hedderman Engineering Inc.

According to HAR, the house was built in 1989.

Orientation - House Facing South:

For the purpose of the inspection, North is considered to be the rear of the house.

I = Inspected NI = Not Inspected NP = Not Present D = Deficient

I	NI	NP	D
---	----	----	---

II. ELECTRICAL SYSTEMS

A. Service Entrance and Panels

Comments:

Electrical System Description :

The electrical service is provided by a 120/240 volt, single-phase, 200-ampere overhead service to an electric meter located at the west side of the house.

Electrical Wiring Information

<u>Service Wires</u>	<u>Branch Circuit Wires</u>	<u>Grounded or Ungrounded System</u>
1/0 copper	copper	grounded

Breaker Panel Information

<u>Location</u>	<u>Manufacturer</u>	<u>Rating</u>
west	Square D	200 amps

Circuit Breaker Wiring Diagram

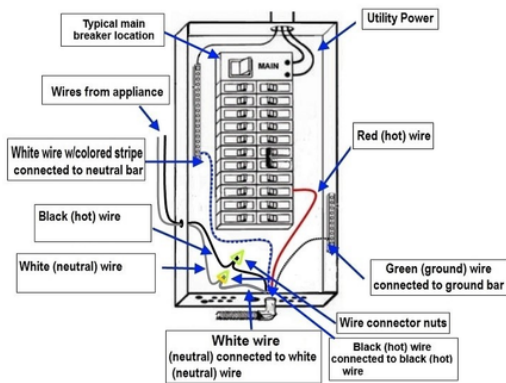

I = Inspected NI = Not Inspected NP = Not Present D = Deficient

I	NI	NP	D
---	----	----	---

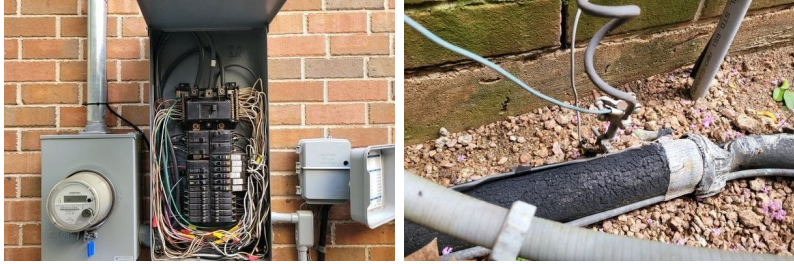

Breakers - Routine Check:

It is a general recommendation that all circuit breakers be tripped off and on at least once a year to ensure that they are still physically able to trip off. Occasionally, the points on a breaker will fuse to the main bus in the panel, preventing the breaker from tripping off, even if there is an overload on the circuit. If this condition occurs, it can be a fire hazard.

AFCI Breakers Not Present - Home built pre-AFCI :

The breaker panel(s) did not contain any Arc Fault Circuit Interrupters (AFCI). This is an “as-built” condition, that does not meet current building code standards. AFCI devices are intended to protect against fires caused by electrical arcing in the wiring, by shutting off the power to the circuit when an electrical arc is detected in the circuit. Homes built prior to 2002 were not required by the National Electrical Code (NEC) to be protected by AFCI devices. Since this home was built prior to 2002, the breaker panel is not required to be retrofitted with new AFCI breakers. If adding AFCI breakers is desired, it is recommended that you contact an electrician for further information.

AFCI Breakers - Several installed:

Several Arc Fault Circuit Interrupter (AFCI) breakers were installed in the breaker panel(s), and the AFCI breakers were protecting some of the 120-volt circuits in the structure. An AFCI breaker is intended to turn off the power to a 120-volt circuit should an electrical arc be detected in the circuit. It is pointed out that in 2002 AFCI breakers began to be phased into the building codes, starting with the bedroom areas. Currently, AFCI breakers are required to be present for the 120-volt circuits throughout the house, with few exceptions. It is pointed out that this house does not meet current standards regarding AFCI breakers, however, local building authorities do not require that this house be retrofitted for additional AFCI breakers. If installing additional AFCI breakers is desired, it is recommended that an electrician be contacted for further information.

AFCI breakers- Not tripped off:

The Arc Fault Circuit Interrupters in the panel were not operationally tested due to the house being occupied. Sudden loss of power can damage some electronic equipment, therefore, as a policy we do not trip off breakers inside an occupied house. If further investigation is desired, it is recommended that a service company be contacted when the house is not occupied or all of the electronics are unplugged.

Breaker panel legend :

The circuit breakers were labeled to identify the circuits they were protecting. We did not trip off every breaker and, therefore, could not verify the accuracy of the labeling. If further investigation is desired, it is recommended that an electrician be contacted.

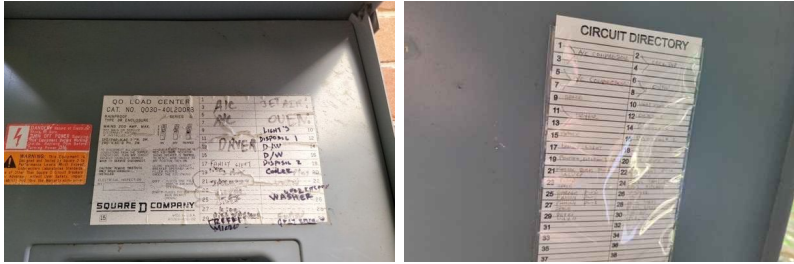

1: Neutral wires double lugged

I = Inspected NI = Not Inspected NP = Not Present D = Deficient

I	NI	NP	D
---	----	----	---

The neutral wires were improperly double lugged in the grounding buses inside the breaker panel. Each wire should be connected to its own lug.

Obtain Cost Estimate

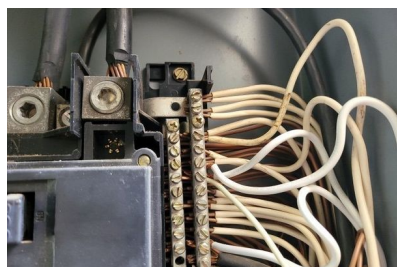

2: Breakers Oversized - A/C condensing unit

Both

The circuit breakers for air conditioning condensing unit was rated higher than the maximum size allowed by the manufacturer of the condensing unit. The breakers should be replaced by the size listed on the manufacturer's nameplates located on the condensing unit.

Obtain Cost Estimate

B. Branch Circuits, Connected Devices, and Fixtures

Comments:

Type of Wiring: Copper - Non-metallic sheathed

GFCI Outlet - Functional : Kitchen counter tops, Kitchen Island -

Outlets that were protected by ground fault circuit interrupt (GFCI) devices were present and functioning properly at the time of the inspection. The GFCI devices were checked and the power to the outlets turned off when the test buttons were pressed. It is pointed out that GFCI devices can stop tripping and/or resetting properly at any point. The devices should be tested periodically and replaced when necessary.

Ceiling Fans - Functional :

No items that were in need of repair were observed for the operation of the ceiling fan(s) at the time of the inspection.

Exterior Light Fixtures - Sensors/Timers:

Several of the exterior lights appeared to be on a daylight sensor or timer, and will not come on until it gets dark. Since it was not dark, the lights were not checked at the time of the inspection. Further investigation is recommended.

1: GFCI - Missing at outlet

Garage, Exterior of the house, Bathrooms -

A GFCI device was not installed at one or more locations that are currently required to have GFCI protection. It is recommended that an electrician install GFCI devices at all of the currently required locations.

Obtain Cost Estimate

2: Light Fixture - Nonfunctional

Attic, Game Room Closet

A light fixture that was non-functional when the switch was on was observed. The problem may be a burned out bulb, defective light fixture, or defective switch.

Further investigation is recommended.

3: Switch - missing

I	NI	NP	D
---	----	----	---

2nd Floor South Bedroom Closet

A switch damaged/missing was observed.

Obtain Cost Estimate

4: Smoke and Carbon Monoxide Detectors

We could not determine if the smoke and/or carbon monoxide detectors are connected to the security alarm system as is common practice, therefore, to avoid triggering the security alarm we did not operationally check each device. Further investigation is recommended with a service company who specializes in this field to determine if the devices are interconnected as currently required and functioning properly. For safety purposes, it is recommended that smoke detectors and carbon monoxide detectors be replaced every ten years. Further investigation is recommended.

5: Carbon Monoxide Detectors - Current standards not met

Carbon monoxide detectors were not installed at all of the currently required locations and it is recommended that approved carbon monoxide detectors be installed. Currently, carbon monoxide detectors are required outside each sleeping area.

Obtain Cost Estimate

6: Low Voltage Systems - Not inspected

It is pointed out that low voltage systems, low voltage wiring, and low voltage connections were not included in the scope of the inspection and were not checked, including: audio/visual systems, alarm systems, data lines, and phone lines. If further investigation is desired, it is recommended that a service company be contacted.

I = Inspected NI = Not Inspected NP = Not Present D = Deficient

I	NI	NP	D
---	----	----	---

III. HEATING, VENTILATION & AIR CONDITIONING SYSTEMS

A. Heating Equipment

Comments:

Type of System: Forced Air

Energy Sources: natural gas

Gas Furnace Description :

The heating for the property was provided the following natural gas-fired equipment:

<u>ZONE</u>	<u>BRAND</u>	<u>BTU</u>	<u>DATE</u>	<u>LOCATION</u>
1st floor	Trane	60k	2011	Attic
2nd floor		80k	2011	

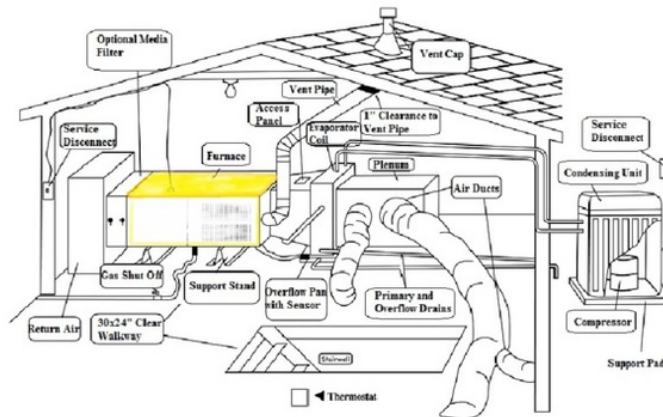

Heating Equipment - Functional:

The heating equipment was observed to be operating and functional at the time of the inspection. The heating equipment responded to the thermostat and the equipment appeared to be heating the air adequately.

Heat Exchanger - Information:

Gas furnaces are constructed in such a way that the units must be dismantled in order to view the entire heat exchanger inside. The equipment was not dismantled, and the heat exchanger was not able to be viewed for evidences of cracks. If further investigation is desired, it is recommended that a service company be contacted to dismantle the equipment. It is pointed out, for safety purposes, the heat exchanger should be inspected by an HVAC service company once a year.

I = Inspected NI = Not Inspected NP = Not Present D = Deficient

I	NI	NP	D
---	----	----	---

Limited visual inspection:

It is pointed out that our inspection of the air conditioning and heating system(s) is a limited, visual inspection where we check the equipment as it has been installed to determine whether or not the system(s) is cooling and/or heating at the time of the inspection. Our inspection is necessarily a cursory inspection, as we do not determine the sizing, adequacy, or design of any component in the system, or the compatibility of the individual components, nor the installation of the system(s) to be in conformity to the latest building code requirements. If you desire an in-depth analysis of the HVAC system(s), then it is recommended that a service company be contacted to analyze the system(s). This is particularly important if the system(s) is an older system and has only a limited amount of remaining life due to its age and/or condition.

B. Cooling Equipment

Comments:

Type of System: Split system

A/C Equipment Description :

The type of air conditioning for the property is a forced air split system. The cooling equipment for the property was as follows:

Zone	Brand	Size/Age Condenser	Size/Age Coil	Temp Drop Degrees
1st floor	Trane	3-ton 2011	4-ton 2011	20
2nd floor	American Standard	3-ton 2018	4-ton 2017	17

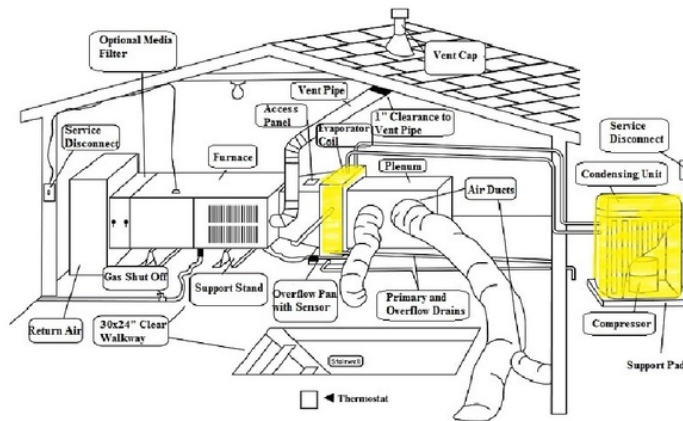

Condensing Unit Equipment - Functional:

The condensing unit equipment was functional at the time of the inspection. The equipment responded to the corresponding thermostat, and the compressor components and fan motor components were operating.



I = Inspected NI = Not Inspected NP = Not Present D = Deficient

I	NI	NP	D
---	----	----	---



Coil Equipment - Functional:

The coil equipment was operating and was providing a degree of cooling at the time of the inspection.

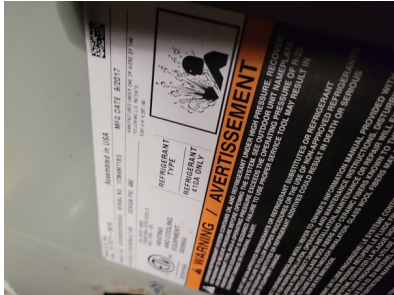

Cooling Performance - Acceptable :

The cooling performance of the equipment was observed to be adequate according to industry standards. The air conditioning equipment was observed to be cooling between 16-20 degrees across the indoor coil at the time of the inspection.

Overflow Pan - Water sensor present:

The overflow pan under the evaporator coil was equipped with a water sensor that is intended to shut off the air conditioning equipment if the pan fills with water.



Primary Drain - Terminated properly:

The primary condensate drain line was properly terminated into the P-trap at a plumbing fixture drain at the interior of the property.

I = Inspected NI = Not Inspected NP = Not Present D = Deficient

I	NI	NP	D
---	----	----	---



Cooling Performance:

We measure the temperature drop (ΔT) across the indoor coil(s) at the time of the inspection and our observations have been recorded in this report. It is pointed out that our measurements of the cooling performance of the equipment is only at a “point in time”, and cannot reflect whether the equipment has been recently serviced, or what the future performance of the equipment will be after the day of the inspection. Further investigation with the homeowner is recommended to determine when the equipment was last serviced.

1: Condensing Unit - Debris inside housing

2nd Floor

Debris was observed to be inside of the housing and needs to be removed and the inside of the unit thoroughly cleaned by a service company.

Obtain Cost Estimate

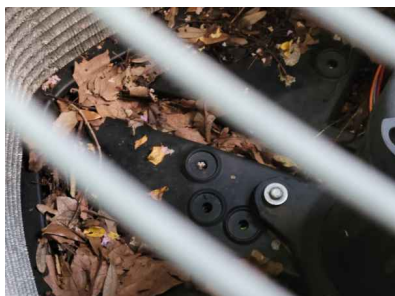

2: Overflow Pan - Rust

Rust was observed in the overflow pan under the coil, apparently due to water backing up at the primary drain line and overflowing into the pan. No water was observed in the overflow pan at the time of the inspection, however since the equipment was only operated for a short time during the inspection, It is recommended that the primary drain line and the coil be checked by an air conditioning service company.

Obtain Cost Estimate

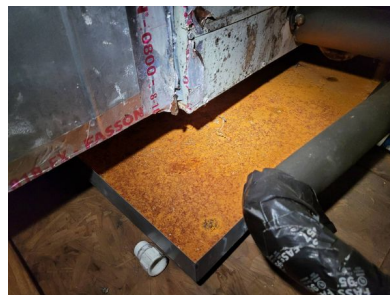

3: Microbial growth on equipment in attic

1st Floor

I = Inspected NI = Not Inspected NP = Not Present D = Deficient

I	NI	NP	D
---	----	----	---

Microbial growth was observed on the outside of the air handler and/or evaporator coil casing. This condition is indicative of a moisture/condensation problem, possibly due to air leaks at the equipment and/or a lack of adequate attic ventilation. Further investigation is recommended with a service company to determine the source of the growth and to determine if the growth is present inside the equipment and/or air ducts. It is recommended that you obtain a cost estimate for any needed repairs.

Further investigation is recommended

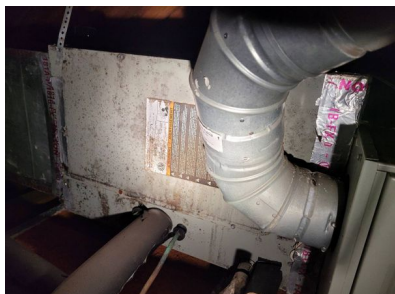

4: Primary Drains - Connected together in attic

The primary condensation drain line for the evaporator coils connect together in the attic rather than terminating independently. The condition can reduce drain performance. Consideration be given to separating the drain lines and terminating each drain line independently in an approved manner.

Obtain cost estimate

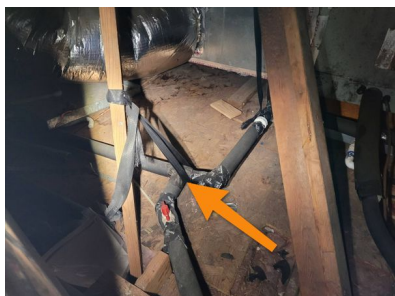

C. Duct System, Chases, and Vents

Comments:

Type: flexible

Duct Work - Acceptable:

The ductwork appeared to be in good condition at the time of the inspection and air was blowing out of each of the registers. The airflow may need to be adjusted in each room to meet your specific needs.

Return Air - Acceptable :

The return air system in the house had no visible items that were in need of repair and appeared to be performing as intended at the time of the inspection.

1: Air filter - dirty

The filter was dirty and needs to be replaced. A dirty filter can allow the evaporator coil and air ducts to become dirty, which can affect the performance of the system.

Obtain Cost Estimate

2: Ducts - Air Leak

The HVAC system was leaking conditioned air at the coil/transition duct/plenum and the system needs to be properly sealed.

Obtain Cost Estimate

I = Inspected NI = Not Inspected NP = Not Present D = Deficient

I	NI	NP	D
---	----	----	---



3: Ducts - No clearance between ducts

We observed that some of the air ducts in the attic were in contact with each other, which can cause condensation to form on the outside of the ductwork. It is recommended that the ducts that are touching be separated. Typically, this is done by inserting a piece of fiberglass batt insulation or duct board between the ducts.

Obtain Cost Estimate



4: Ducts - Sheathing/Insulation damaged

The sheathing and/or insulation around the air ducts is damaged/missing, and the damaged duct work needs to be repaired or replaced.

Obtain Cost Estimate



I = Inspected NI = Not Inspected NP = Not Present D = Deficient

I	NI	NP	D
---	----	----	---

IV. PLUMBING SYSTEMS

A. Plumbing Supply, Distribution Systems, and Fixtures

Shut Off Valve - Exterior location:

The shut-off valve for the main inlet water line was located at the exterior of the house.

West



Static Water Pressure :

The static water pressure to the house at the time of the inspection was measured with a pressure gauge at the hose bibb nearest the shut off valve, and the static pressure was observed to be 50 psi.



Toilets - Functional:

No items requiring repair were visible at the time of the inspection to the operation of the toilets. The toilets were flushing properly, with no leaks visible in the plumbing, the wax seal, or the internal valves.

Shower - No evidence of shower pan leak:

No evidence of a current shower pan leak were visible at the time of the inspection for the shower(s). It is pointed out, our shower inspection is limited to a visual inspection and we did not perform a shower pan leak test. It is recommended that a plumber be contacted to perform a shower pan leak test to determine if any water is leaking past the shower pan.

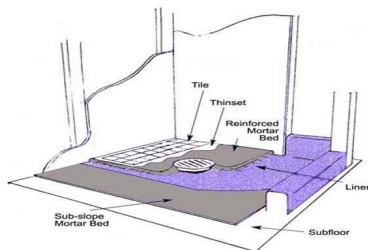

1: Vacuum Breaker - Missing

The atmospheric vacuum breaker devices were missing at one or more of the hose bibbs, and it is recommended that they be installed to prevent cross connections, which can allow contaminated water to enter the potable water supply.

Obtain Cost Estimate

I	NI	NP	D
---	----	----	---



2: Water Stains - High moisture detected

Garage and 2nd Floor Bathroom toilet area

Water damage/stains were observed indicating a current or previous leak. The source of the condition was not determined, with certainty, at the time of the inspection. The stains were checked with a moisture meter and elevated moisture levels (15% or higher) were observed at the time of the inspection.

Further investigation is recommended with a contractor to determine the source of the condition and to make any necessary repairs to correct the moisture condition and, if present, any secondary damage.

Obtain Cost Estimate

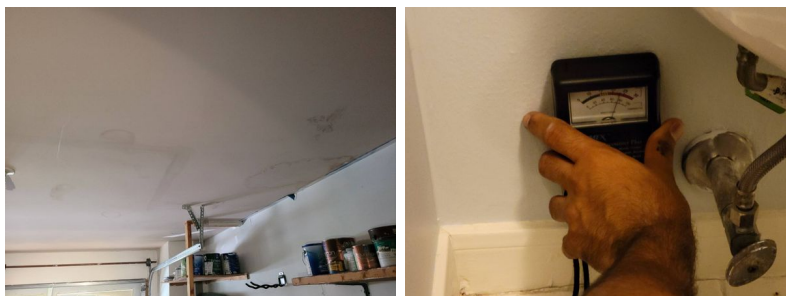

3: Faucet - Drip leaking

Kitchen

A drip leak that needs to be repaired was observed at a faucet.

Obtain Cost Estimate

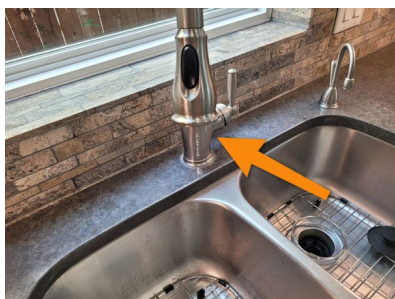

4: Drain Stopper - Nonfunctional

2nd Floor Bathroom Master Bath

I = Inspected NI = Not Inspected NP = Not Present D = Deficient

I	NI	NP	D
---	----	----	---

A drain stopper was nonfunctional and needs to be repaired.

Obtain Cost Estimate

5: Tub/Shower - Water leaks past diverter

2nd Floor Bathroom

The diverter valve was leaking water past the valve when the valve was turned to the shower.

Obtain Cost Estimate



B. Drains, Wastes, & Vents

Comments:

Sewer Piping Material: pvc

Sewer System - Functional:

No items requiring repair were visible for the operation of the drain system at the time of the inspection. No evidences of a system wide problem were observed when the system was operationally checked by running water through each of the plumbing fixtures during the duration of the inspection. It is noted that most of the drain waste system in the walls, under the floors, and in the ceilings is not visible. If further investigation is desired, it is recommended that a plumber be contacted to perform an in depth survey with a camera or hydrostatic test.

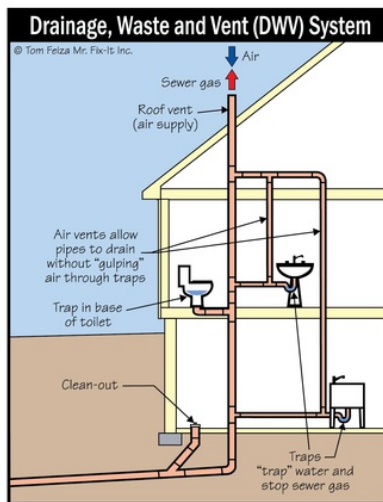

Sewer Clean Out - Present :

A sewer clean out was present. The clean out is needed in the event of a stoppage in the main sewer drain line, and the clean out is where a sewer snake would be utilized to remove a clog in the sewer line.

Front

I = Inspected NI = Not Inspected NP = Not Present D = Deficient

I	NI	NP	D
---	----	----	---

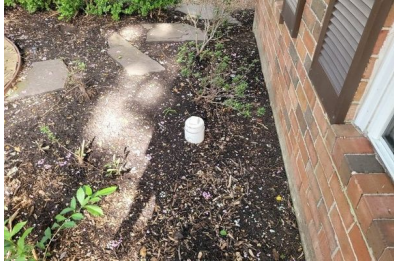

C. Water Heating Equipment

Comments:

Energy Source: natural gas

Capacity: 50 gls

Gas Water Heater Description:

The hot water for the property was provided by the following natural gas fired gas water heater(s):

<u>Location</u>	<u>Brand</u>	<u>Capacity</u>	<u>Age</u>	<u>Energy Type</u>
Attic	State Select	50 gls	2017	Gas

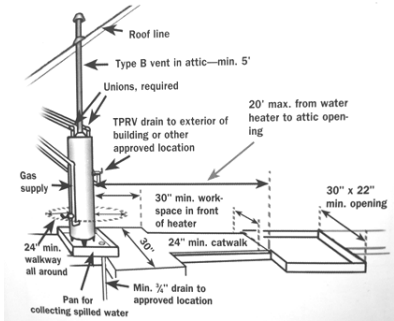

Water Heater Equipment - Functional:

The water heater equipment was functional at the time of the inspection and providing hot water to the applicable plumbing fixtures.

Temp/Pressure Relief Valve - Information :

Temperature/pressure relief valves are not operationally checked by this firm during the inspection.

Valves typically do not reseal properly when they are operated, which causes the valves to leak. It is best to replace the temperature/pressure relief valves for water heaters every 2-3 years to prevent them from getting clogged with mineral deposits.

D. Hydro-Massage Therapy Equipment

Comments:

Whirlpool - Functional:

The whirlpool tub was functional, and the recirculation pump and aerators were operating properly when we engaged the controls. Also, the equipment was protected by a Ground Fault Circuit Interrupt device and the device was functioning properly at the time of the inspection.

I = Inspected NI = Not Inspected NP = Not Present D = Deficient

I	NI	NP	D
---	----	----	---

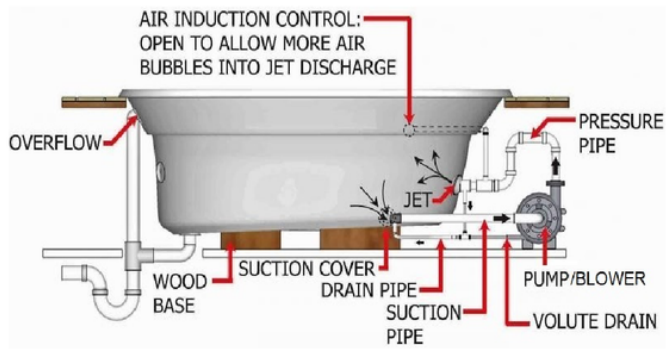

E. Gas Supply System

Comments:

Gas Meter Location :

The main gas shut off valve was located at the inlet side of the gas service meter.

West

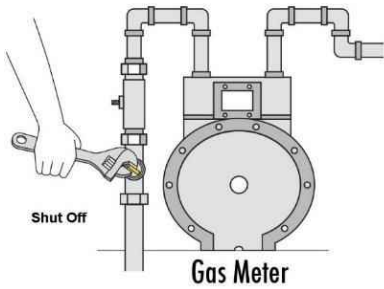

Gas System Inspection :

A cursory visual inspection was performed on the gas supply piping. The inspection was limited to the gas pipes that were visible and accessible at the time of the inspection. The use of specialized equipment to detect leaks is not included in the scope of this inspection, nor is determining the gas supply pressure or adequacy. If further investigation is desired, it is recommended that a plumber be contacted.

I = Inspected NI = Not Inspected NP = Not Present D = Deficient

I	NI	NP	D
---	----	----	---

V. APPLIANCES

A. Dishwashers

Comments:

Functional :

The left dishwasher was functioning and responded to the controls. The unit was run through a cycle at the time of the inspection and appeared to be operating properly.

Drain Line Loop Present :

The drain line under the sink was looped up so that the top of the loop was higher than the point where the drain line connected to the disposal. This will help to prevent garbage from running down the drain line into the dishwasher.

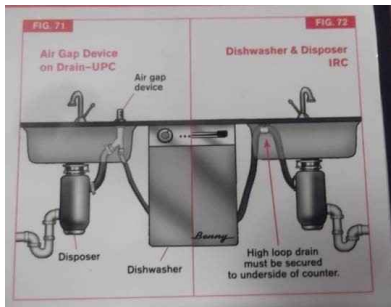

1: Nonfunctional

The right dishwasher was nonfunctional at the time of the inspection. The reason for the condition was not apparent. The unit should needs to be checked by a service company who should provide a cost estimate to repair or replace the equipment.

Obtain Cost Estimate



B. Food Waste Disposers

Comments:

Functional:

The disposal was operating and responded to the controls at the time of the inspection.

Left

Limited Life:

The disposal was functional at the time of the inspection. However, the age and condition of the equipment, it is our opinion that it has only a limited amount of life remaining.

Both

1: Nonfunctional

Right

I = Inspected NI = Not Inspected NP = Not Present D = Deficient

I	NI	NP	D
---	----	----	---

The disposal was nonfunctional at the time of the inspection. The reason was not apparent, and the unit needs to be checked out by a service company who should provide a written statement of the condition of the equipment.

Obtain cost estimate



C. Range Hood and Exhaust Systems

Comments:

Downdraft Vent - Functional:

The downdraft vent was turned on and was functioning at the time of the inspection. The equipment responded to the controls and vented to the outside.



1: Vent Pipe - leaking air

The vent pipe was leaking air into the kitchen cabinet and needs to be sealed.

Obtain Cost Estimate



D. Ranges, Cooktops, and Ovens

Comments:

Electric Oven - Functional:

The electric oven was observed to be functioning and no items requiring repair were visible at the time of the inspection.

Ovens - Upper/Lower calibrated properly:

Both oven thermostats were checked and were properly calibrated. The thermostats were set at 350 degrees, and the ovens heated to within the allowable ± 25 degrees. The ovens were checked with an oven thermometer and found to heat to 360 degrees for the upper oven, and 370 degrees for the lower oven.

I = Inspected NI = Not Inspected NP = Not Present D = Deficient

I	NI	NP	D
---	----	----	---



Electric Induction Cooktop:

The electric cooktop was an induction type cooktop and the burners will not heat unless steel cookware is in contact with the burner. It is pointed out that the required cookware was not present at the time of the inspection and the cooktop was not operated.

Further investigation is recommended



E. Microwave Ovens

Comments:

Functional:

No items requiring repair were visible at the time of the inspection for the heating operation of the microwave. A cup of water was placed in the unit, and the microwave heated the water adequately. It is pointed out that the unit was not checked for microwave leakage.

F. Mechanical Exhaust Vents and Bathroom Heaters

Comments:

Mechanical Vents - Functional:

The mechanical vent fans were functional at the time of the inspection. The bath vent fans responded to the switches and were functional at all the bathrooms.

G. Garage Door Operators

Comments:

1: Opener - did not auto-reverse

The garage door opener did not stop the descent of the door when the door was subjected to a reasonable resisting pressure. This could cause possible personal injury or damage to house, and the opener is in need of adjustment. It is pointed out that the unit was equipped with the infra-red sensing safety device, and the device was operational at the time of the inspection.

Obtain Cost Estimate

I = Inspected NI = Not Inspected NP = Not Present D = Deficient

I	NI	NP	D
---	----	----	---



2: Sensors too high

The infrared device was located too high on the garage door, and should be located no more than six inches above the floor. It is recommended that the device be lowered.

Obtain Cost Estimate

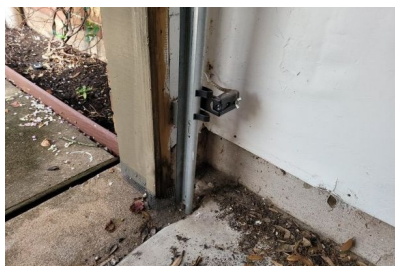

H. Dryer Exhaust Systems

Comments:

Dryer vent - Dryer present :

The vent was connected to the dryer but was not tested. It is recommended that the vent be checked for an excess of lint and that it be cleaned if necessary. (Information)



I. Other

Comments:

Non Built-in Equipment - Not inspected :

It is pointed out that non built-in refrigerators, wine coolers, small refrigerators, clothes washers, and clothes dryers are not included in the scope of this inspection and were not checked. If further investigation is desired, it is recommended that a service company be contacted.

Further investigation is recommended

Washer/Dryer Connections - Not visible :

No access was provided behind the washer and dryer and the area was not visible for inspection. Further investigation is recommended. It is also recommended that you check with the owner to determine which dryer connection options are available.

I = Inspected NI = Not Inspected NP = Not Present D = Deficient

I	NI	NP	D
---	----	----	---



I = Inspected NI = Not Inspected NP = Not Present D = Deficient

I	NI	NP	D
---	----	----	---

VI. OPTIONAL SYSTEMS

A. Landscape Irrigation (Sprinkler) Systems

Comments:

Sprinkler System: Hunter, Located at west side of house, 6 zones -

An automatic sprinkler system was installed. The system included a control panel, one or more solenoid valves, underground water lines and with sprinkler heads.

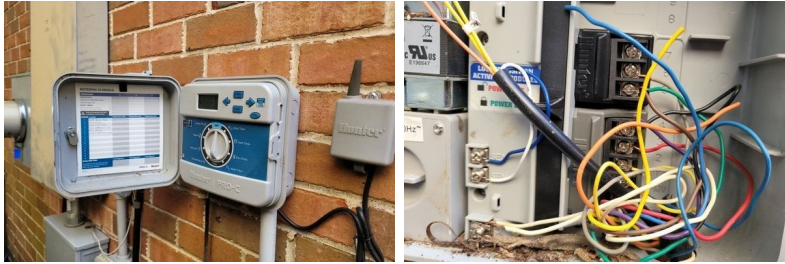

Backflow Prevention Device - present:

A backflow prevention device was present and was equipped with the two water shut off valves on the water supply line to the sprinkler system.

West



Rain Sensor: Rain Sensor - Present -

It is currently required for automatic sprinkler systems to be equipped with a rain sensor device that will prevent the sprinkler system from operating during and shortly after a significant rain.

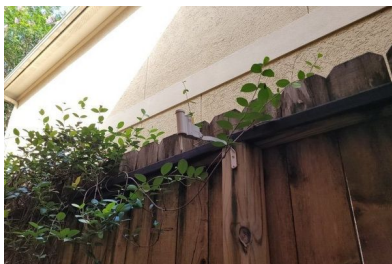

1: Spraying - House

Zones 3,6

The sprinkler system was spraying the house and needs to be adjusted.

Obtain Cost Estimate

2: Head Clogged

Zone 1

A sprinkler head that was not spraying properly and appeared to be clogged was observed.

Obtain Cost Estimate

I = Inspected NI = Not Inspected NP = Not Present D = Deficient

I	NI	NP	D
---	----	----	---



3: Spraying Fence

Zones 3,4

The sprinkler system was spraying the fence and needs to be adjusted to prevent premature deterioration of the fence.

Obtain cost estimate

I	NI	NP	D
---	----	----	---

INFORMATION FROM HEDDERMAN ENGINEERING INC.

Closing Comments :

Opinions and comments stated in this report are based on the apparent performance of the items included within the scope of the inspection, at the time of the inspection. Performance standards are based on the knowledge gained through the experience and professional studies of the inspector. There is no warranty or guarantee, either expressed or implied, regarding the habitability, future performance, life, merchantability, and/or need for repair of any item inspected. It is recommended that a Home Warranty Policy be provided to protect the appliances and mechanical equipment against unforeseen breakdowns during the first year. Check with your agent for details.

Items identified in the report as Deficient and our Recommendations are provided in the above report. Many, but not all, recommendations are highlighted in bold red text. It is our intention, and your responsibility, that you follow up on these deficiencies and recommendations as part of your due diligence by contacting the appropriate service contractor for Further Investigation, Obtain cost estimate, and/or Contact the builder before your option period expires. It is pointed out that other related and/or underlying conditions may be present, and which may not be apparent without further investigation.

As an additional service, we strongly recommend using a new tool we have on our website that can quickly turn your inspection report into an easy-to-read estimate of repairs for a nominal fee. These pricing reports from a third party company called Repair Pricer not only make the inspection report easy to understand in terms of dollars and cents, but they are also useful negotiation tools. Just visit the page below on our website and upload your report into Repair Pricer. If you have any questions when you receive your report, you can contact them at info@repairpricer.com <http://www.heddermanengineering.com/repair-cost-estimates>