

1 FLOOR PLAN
SCALE: 1/4"=1'-0"

ALL CONSTRUCTION SHALL BE IN COMPLIANCE WITH THE 2015 IECC

NOTE:
DO NOT SCALE-OFF DIRECTLY FROM DRAWING.
CONTRACTOR SHALL FIELD VERIFY DIMENSIONS.

1. THE CONSTRUCTION OF THIS DWELLING MUST COMPLY WITH INTERNATIONAL RESIDENTIAL CODE
2. DO NOT SCALE-OFF DIRECTLY FROM DRAWING. CONTRACTOR SHALL VERIFY AND WORK WITH DIMENSIONS SHOWN. ALL DIMENSION SHALL BE VERIFY IN SITE.
3. SINGLE HUNG ALUMINUM WINDOWS UNO 8'-0" HEADER HT. AT 9' - 0" PLATE
4. CHIMNEYS TO BE 2'-0" (MIN.) ABV. ANY ROOF LINE WITHIN A 10'-0" RADIUS.
5. THE ATTIC ACCESS STAIRWAY SHALL COMPLY WITH SECTION M 1305.1.3 AS AMENDED: ACCESS SHALL BE PROVIDED WITH A PULL DOWN STAIRWAY WITH A CLEAR OPENING NOT LESS THAN 22 INCHES IN WIDTH AND LOAD CAPACITY OF NOT LESS THAN 350 POUNDS. THE PASSAGEWAY SHALL HAVE CONTINUOUS SOLID FLOORING IN ACCORDANCE WITH CHAPTER 5 OF THE IRC. AND NO LESS THAN 24 INCHES WIDE. A LEVEL SERVICE SPACE AT LEAST 30 INCHES DEEP AND 30 INCHES WIDE SHALL BE PRESENT ALONG ALL SIDE OF THE APPLIANCE WHERE ACCESS IS REQUIRED. THE CLEAR ACCESS OPENING DIMENSIONS SHALL BE MINIMUM OF 20 INCHES BY 30 INCHES, WHERE SUCH DIMENSIONS ARE LARGE ENOUGH TO ALLOW REMOVAL OF THE LARGEST APPLIANCE.
6. 8'-0" INTERIOR DOORS AT FIRST FLOOR
7. WHERE WOOD FRAMING IS EXPOSED TO WATER SPLASHING, PROVIDE WATERPROOF PAPER FLASHING AND COUNTER FLASHING.
8. SEE OWNER/CONTRACTOR FOR WINDOW MANUFACTURER AND STYLES. WINDOW SUPPLIER TO LOCATE SAFETY GLASS AS REQUIRED & CERTIFY ALL WINDOW TO COMPLY WITH 2021 I.B.C. I.R.C. AND 2015 ENERGY CODE. PROVIDE MASTIC WRAP. WATERPROOFING AND CAULK SURROUND FLASHING ABOVE WINDOWS AND COUNTER-FLASH AS REQUIRED
9. ALL GLAZING LOCATED IN DOORS TO BE SAFETY GLAZING
10. HOUSEHOLD VENTING SHALL BE OUTSIDE DWELLING. PROVIDE VENTILATION AT ALL BATHS AND UTILITY ROOMS VIA NATURAL OR MECHANICAL MEANS CAPABLE OF FIVE AIR CHANGES PER HOUR AND IS VENTED DIRECTLY OUTSIDE WITH A POINT OF DISCHARGE MIN.
11. HVAC INSTALLATION, SIZING, LOCATION IS THE RESPONSIBILITY OF A/C CONTRACTORS
12. ALL LAVATORIES 2'-8" HIGH U.N.O.
13. ALL SHEETROCK CORNER TO BE ROUNDED, EXCLUDING CORNERS AT WINDOW.
14. CROSS VENTILATION AT ENCLOSED ATTICS, SIZE PER CODE CALCULATION.

2 GENERAL NOTES
SCALE: N.T.S.

TABULATIONS	
LIVING AREA:	* 2,508 SQ.FT
GARAGE:	470 SQ.FT
COVID PORCH:	50 SQ.FT
TOTAL COVID:	3,028 SQ.FT
COVID PATIO (opt):	340 SQ.FT
TOTAL COVID:	3,368 SQ.FT

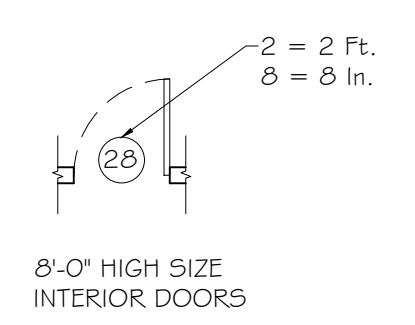

3 DOOR LEGEND
SCALE: N.T.S.

project:
NEW 1-STORY HOUSE
125 BIRDIE DRIVE
HEMPSTEAD, TX. 77445

COMMENTS:
2/2/23 NEW FOOTAGE ADD*

FLOOR PLAN

sheet: **A1.0**