

The Woods of Conroe

THOMASTON



Elevation C ✕



Elevation D



Elevation E



Elevation F

Centex

put yourself in
a better place[®]



In our continuing effort to improve our product, Centex Homes reserves the right to make changes or modifications to plan specifications, materials, features, or floor plans without notice. Room dimensions are approximate and actual square footage may vary by elevation. Please see a sales associate for details. Renderings are for illustrative purposes only and is not intended to be an actual representation of a specific home being offered. Square footages listed are approximate. This material shall not constitute a valid offer in any state where prior registration is required or if void by law. Additional conditions, limitations, and restrictions apply; see a sales associate for details. © 2020 Centex Homes. All rights reserved. 2/20

The Woods of Conroe

THOMASTON

2,465 Square Feet

- 4 Bedrooms
- 2.5 Baths
- Flex Room and Loft
- 2-Car Garage

OPTIONAL:

- Study in lieu of Flex
- Bedroom in lieu of Flex
- Uncovered or Covered Patio
- Owner's Bath:
 - Shower
 - Garden Tub with Shower
 - Double Vanity
 - Knee Space
 - Linen Closet

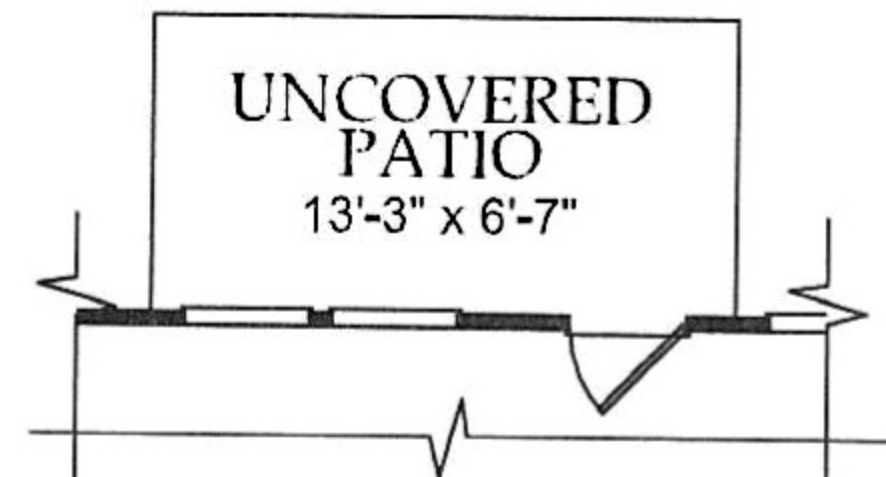

Opt. Uncovered Patio

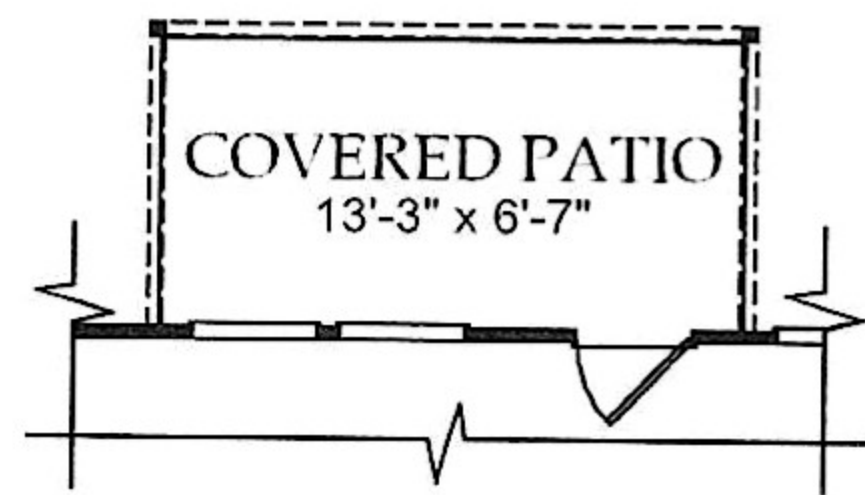

Opt. Covered Patio

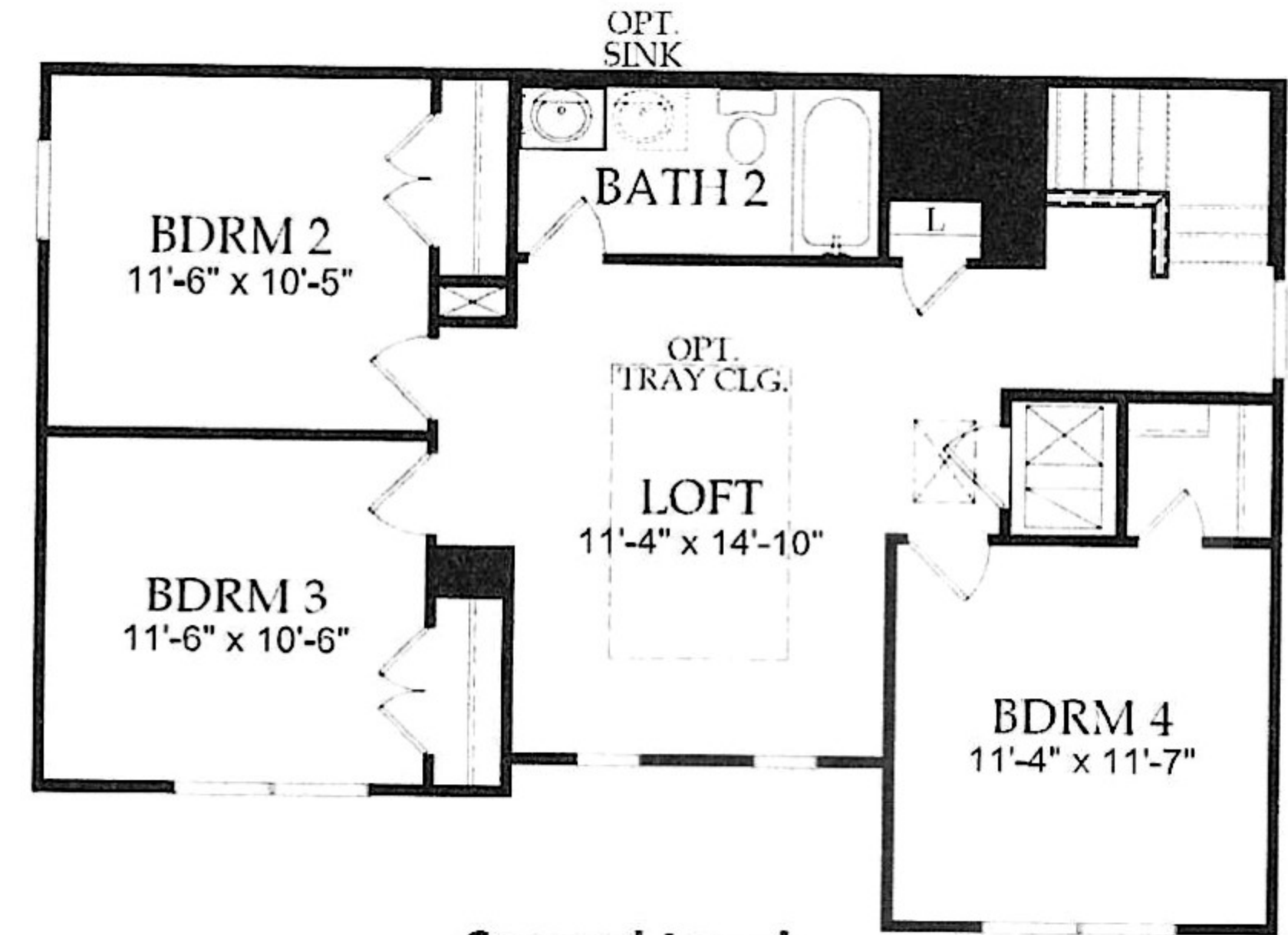

Second Level

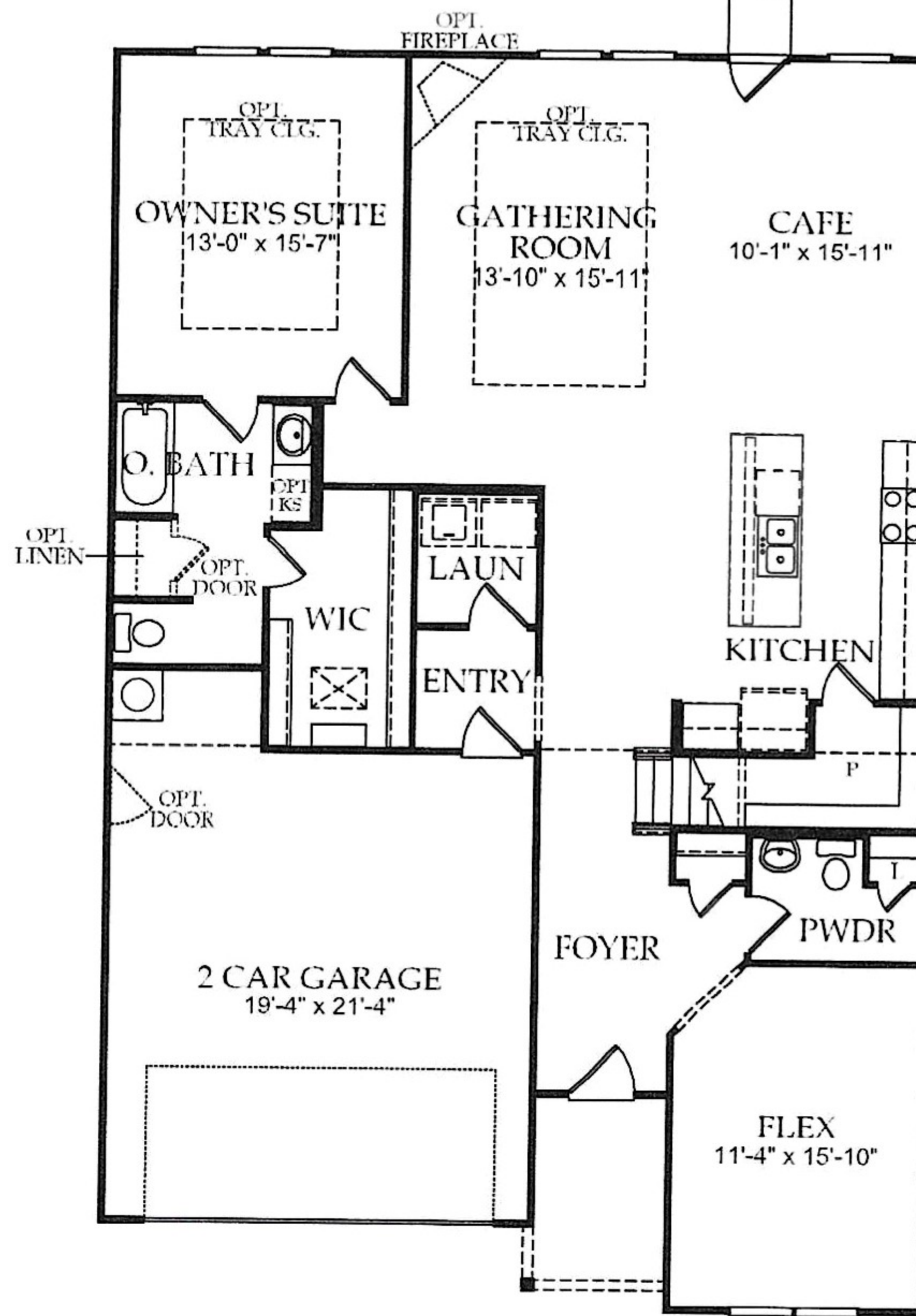

First Level

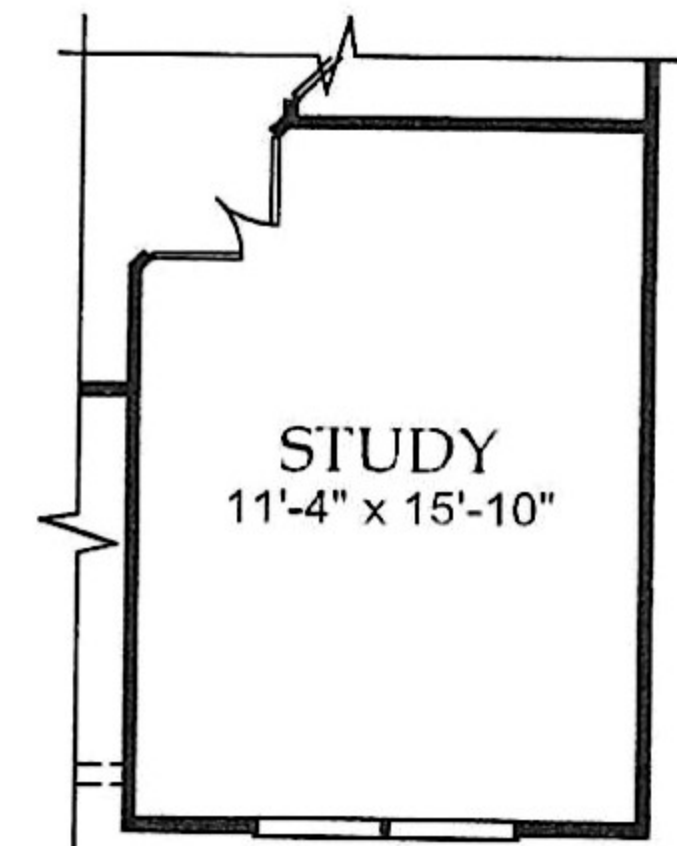

Study ILO Flex

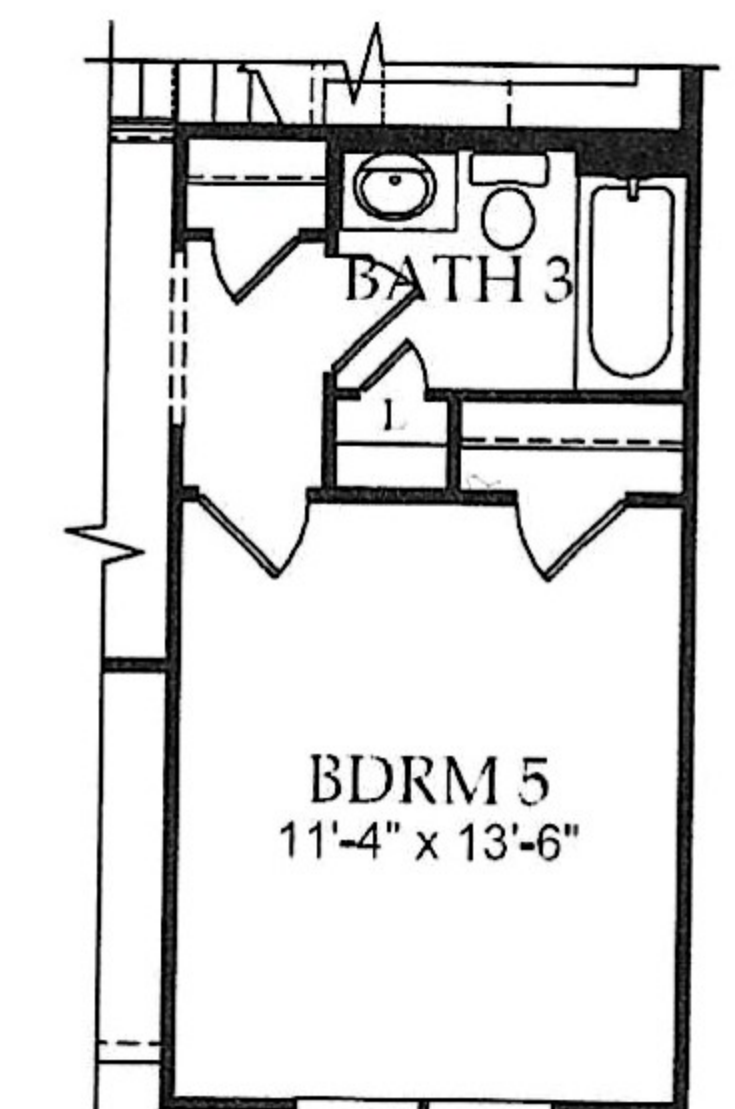

Bedroom ILO Flex

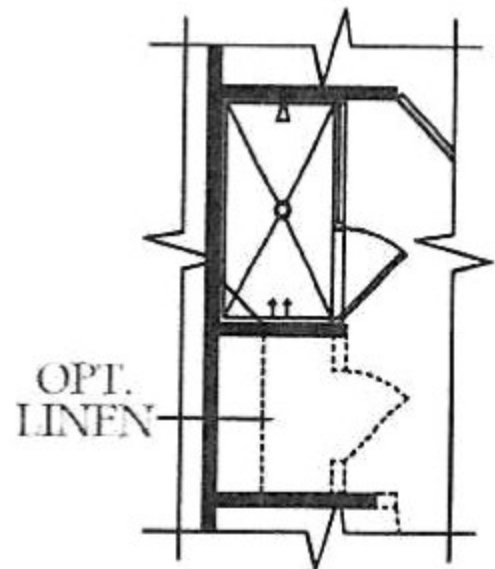

Owner's Bath
Opt. 1

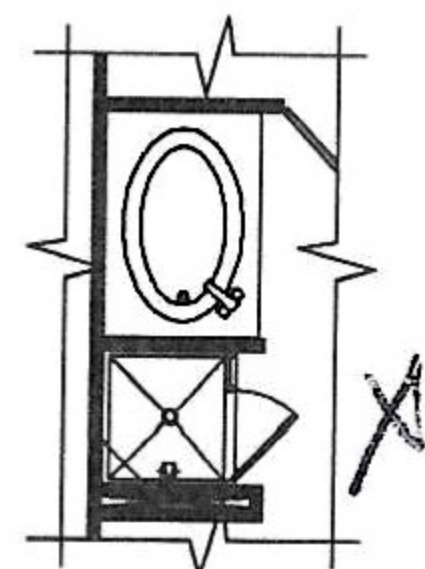

Owner's Bath
Opt. 2

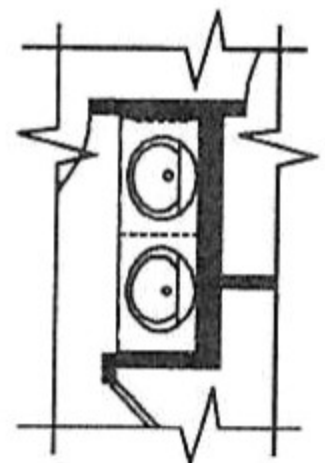

Owner's Bath
Dbl. Sink Opt.

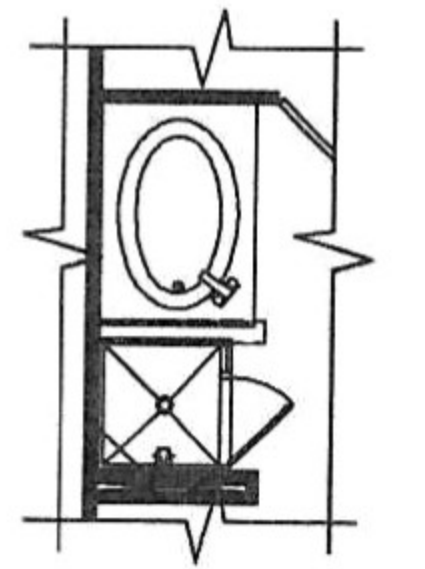

Owner's Bath
Opt. 3