

PURDON RESIDENCE
 26232 LAURENS COURT
 LOT: 1 BLK: 2 SEC: 1 PLOT: 1
 MONTGOMERY, TEXAS 77316
 CROWN RANCH

DUNN & STONE
 BUILDERS

REVISIONS

NO.	DESCRIPTION

DATE: 01/15/11
 DRAWN BY: J. STONE
 CHECKED BY: J. STONE
 PROJECT NO: 11-001
 SHEET NO: 0-1
 TOTAL SHEETS: 1

0-1

EXPLANATORY NOTES:

1. ALL DIMENSIONS ARE TO FACE UNLESS NOTED OTHERWISE.
 2. ALL DIMENSIONS ARE TO FACE UNLESS NOTED OTHERWISE.
 3. ALL DIMENSIONS ARE TO FACE UNLESS NOTED OTHERWISE.
 4. ALL DIMENSIONS ARE TO FACE UNLESS NOTED OTHERWISE.
 5. ALL DIMENSIONS ARE TO FACE UNLESS NOTED OTHERWISE.
 6. ALL DIMENSIONS ARE TO FACE UNLESS NOTED OTHERWISE.
 7. ALL DIMENSIONS ARE TO FACE UNLESS NOTED OTHERWISE.
 8. ALL DIMENSIONS ARE TO FACE UNLESS NOTED OTHERWISE.
 9. ALL DIMENSIONS ARE TO FACE UNLESS NOTED OTHERWISE.
 10. ALL DIMENSIONS ARE TO FACE UNLESS NOTED OTHERWISE.

NOTES:
 1. ALL DIMENSIONS ARE TO FACE UNLESS NOTED OTHERWISE.
 2. ALL DIMENSIONS ARE TO FACE UNLESS NOTED OTHERWISE.
 3. ALL DIMENSIONS ARE TO FACE UNLESS NOTED OTHERWISE.
 4. ALL DIMENSIONS ARE TO FACE UNLESS NOTED OTHERWISE.
 5. ALL DIMENSIONS ARE TO FACE UNLESS NOTED OTHERWISE.
 6. ALL DIMENSIONS ARE TO FACE UNLESS NOTED OTHERWISE.
 7. ALL DIMENSIONS ARE TO FACE UNLESS NOTED OTHERWISE.
 8. ALL DIMENSIONS ARE TO FACE UNLESS NOTED OTHERWISE.
 9. ALL DIMENSIONS ARE TO FACE UNLESS NOTED OTHERWISE.
 10. ALL DIMENSIONS ARE TO FACE UNLESS NOTED OTHERWISE.

ITEM	QUANTITY	UNIT	PRICE	TOTAL
CONCRETE	100	YD	120.00	12000.00
BRICK	500	1000	10.00	5000.00
WOOD	200	1000	15.00	3000.00
ROOFING	100	1000	8.00	800.00
MECHANICAL	50	1000	12.00	600.00
ELECTRICAL	30	1000	10.00	300.00
PAINT	20	1000	15.00	300.00
LANDSCAPE	10	1000	20.00	200.00
TOTAL COST				23000.00

FIRST FLOOR PLAN

5' 1/2" = 1'-0"

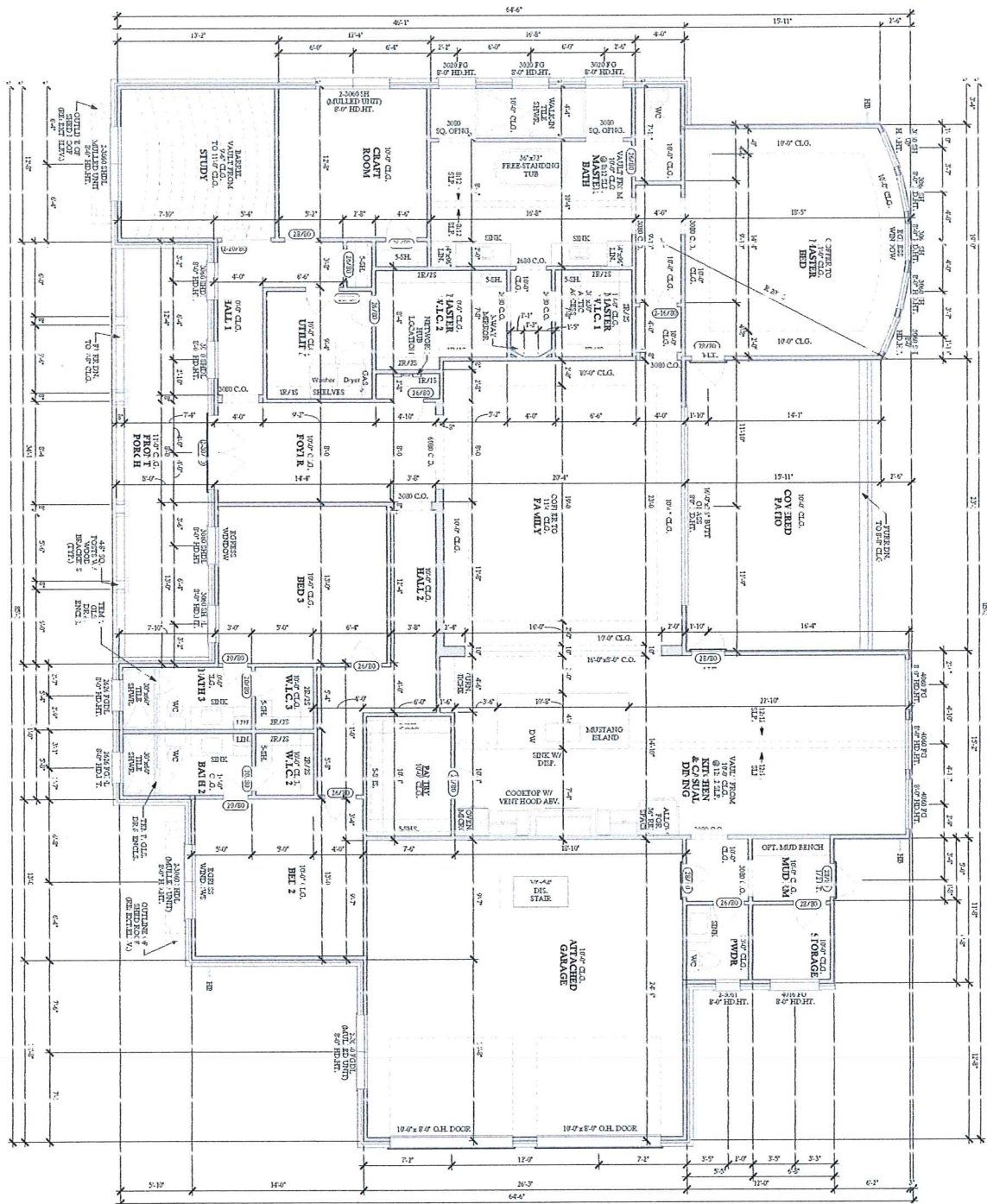

PURDON RESIDENCE
 2632 LAURENS COURT
 MONTGOMERY, TEXAS 77136
 CROWN RANCH

DATE: 1/1/10
 DRAWN BY: [Name]
 CHECKED BY: [Name]
 PROJECT NO: [Number]
 SHEET NO: [Number]

DUNN & STONE
 BUILDERS

NO.	REVISIONS

A-1

REVISIONS

NO.	DATE	DESCRIPTION

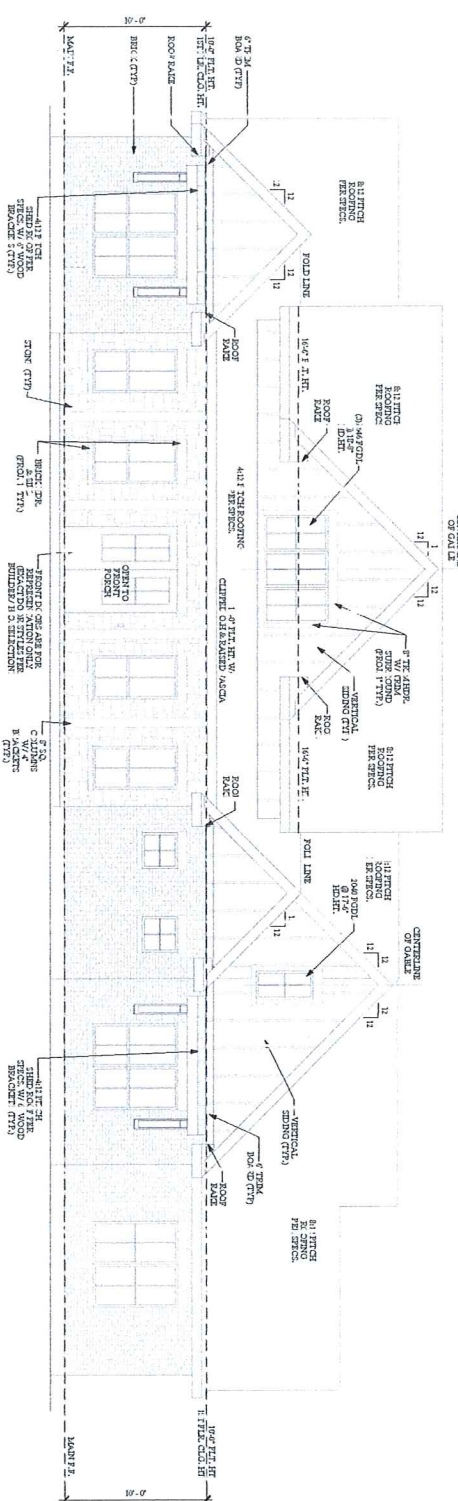

FRONT ELEVATION
SCALE: 1/4" = 1'-0"

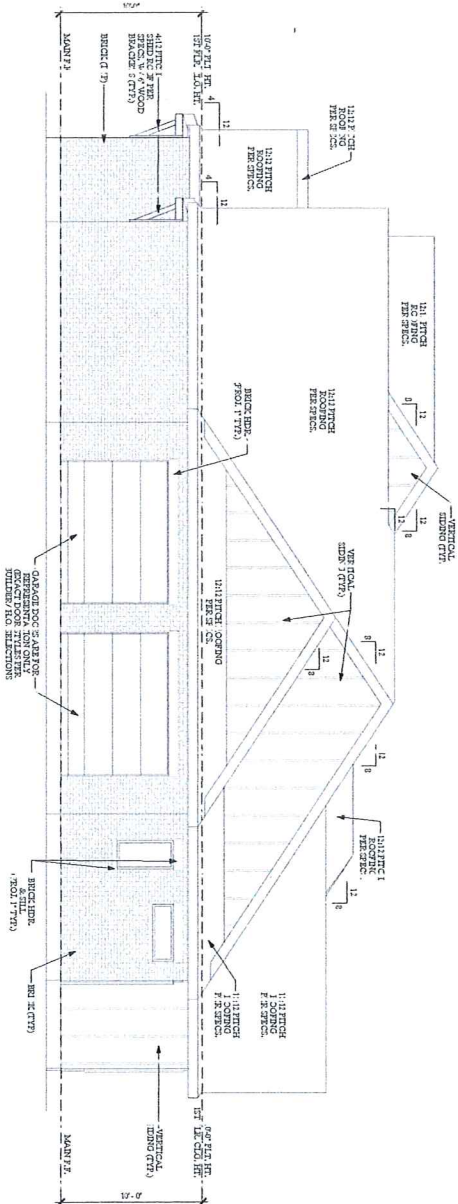

RIGHT ELEVATION
SCALE: 1/4" = 1'-0"

PURDON RESIDENCE
26232 LAUREN'S COURT
MONTGOMERY, TEXAS 77316
CROWN RANCH

SCALE	1/4" = 1'-0"
DATE	C-09-28
BY	TJH
CHECKED	
APP'D	

A-3

DUNN & STONE
BUILDERS

EXPLANATIONS:
 THE USE OF CONTINGENTS TO CORRECT WITH ALL THE CHANGES BE CAUSED BY REFER TO LOCAL APPLICABLE CODES FOR OPERATING THE WORK ORDER OR DO NOT CALL BAWMS. WHETHER CHANGES TO VERIFY AND BE CONSULTED WITH THE ARCHITECT AND CONSULTING ENGINEER AND NOTIFY OF ANY CHANGES TO THE DRAWINGS OR REVISIONS. ON THESE DRAWINGS SHALL HAVE RESOURCES OVER THE PROJECT.
 ALL ROOF WINDOW SHALL BE IN A WINDOW AS SHOWN. ALL ROOF WINDOW SHALL BE OPEN TO THE ROOF FROM THE INTERIOR. ALL WINDOWS SHALL BE FROM THE INTERIOR. ALL WINDOWS SHALL BE FROM THE INTERIOR. ALL WINDOWS SHALL BE FROM THE INTERIOR.
 ALL ROOF WINDOWS SHALL BE IN A WINDOW AS SHOWN. ALL ROOF WINDOW SHALL BE OPEN TO THE ROOF FROM THE INTERIOR. ALL WINDOWS SHALL BE FROM THE INTERIOR. ALL WINDOWS SHALL BE FROM THE INTERIOR.
 ALL ROOF WINDOWS SHALL BE IN A WINDOW AS SHOWN. ALL ROOF WINDOW SHALL BE OPEN TO THE ROOF FROM THE INTERIOR. ALL WINDOWS SHALL BE FROM THE INTERIOR. ALL WINDOWS SHALL BE FROM THE INTERIOR.
 ALL ROOF WINDOWS SHALL BE IN A WINDOW AS SHOWN. ALL ROOF WINDOW SHALL BE OPEN TO THE ROOF FROM THE INTERIOR. ALL WINDOWS SHALL BE FROM THE INTERIOR. ALL WINDOWS SHALL BE FROM THE INTERIOR.
 ALL ROOF WINDOWS SHALL BE IN A WINDOW AS SHOWN. ALL ROOF WINDOW SHALL BE OPEN TO THE ROOF FROM THE INTERIOR. ALL WINDOWS SHALL BE FROM THE INTERIOR. ALL WINDOWS SHALL BE FROM THE INTERIOR.

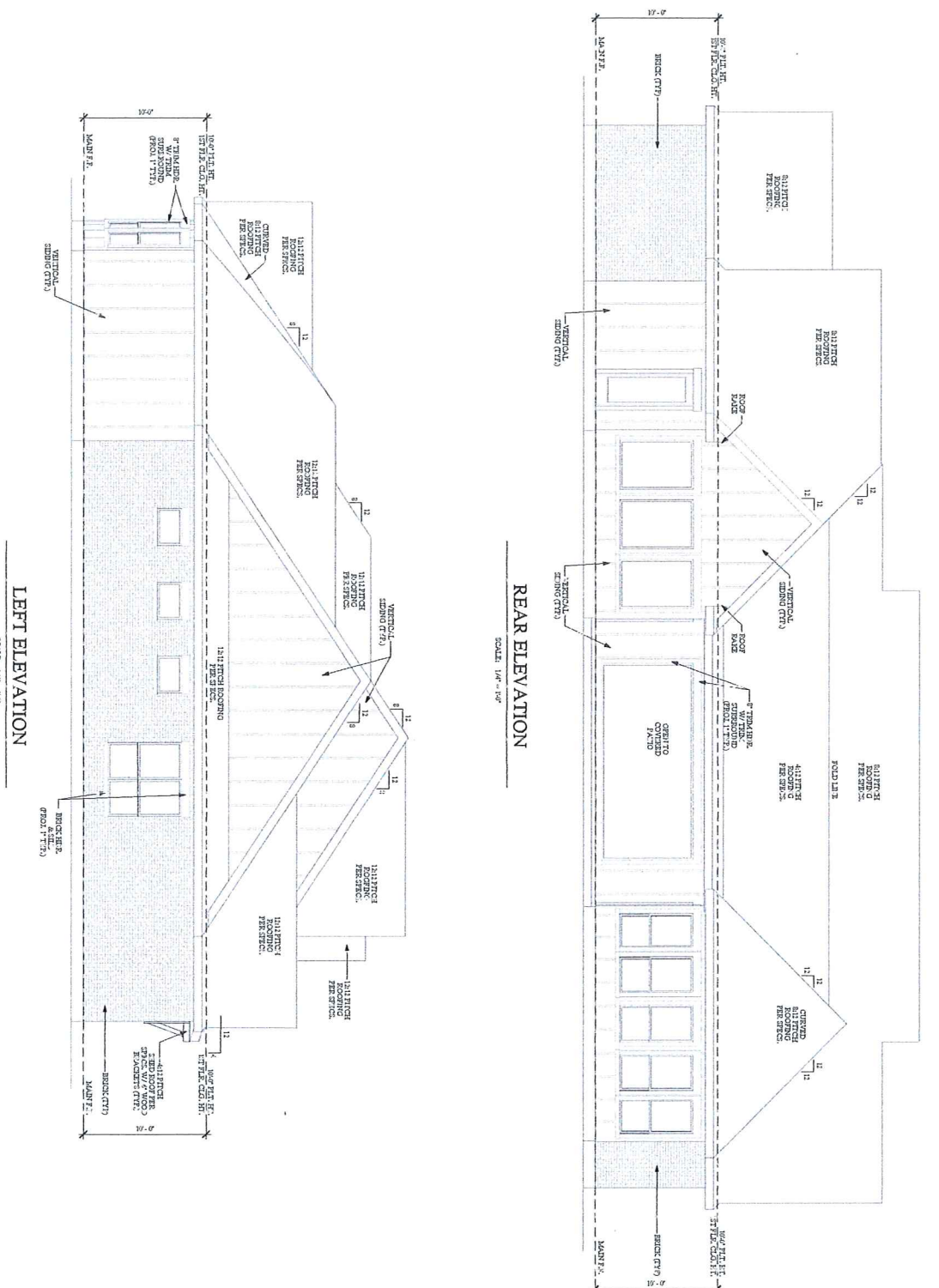

REAR ELEVATION
 SCALE: 1/4" = 1'-0"

LEFT ELEVATION
 SCALE: 1/4" = 1'-0"

REVISIONS	
NO.	DESCRIPTION

DUNN & STONE
 BUILDERS

PURDON RESIDENCE
 2622 LAUREN'S COURT
 BLOCK 5, SECTION 11
 MONTGOMERY, TEXAS 77316
 CROWN RANCH

DATE:	1/11/14
SCALE:	1/4" = 1'-0"
PROJECT:	152
CLIENT:	CROWN RANCH
DRAWN BY:	EXTERIOR ELEVATIONS

PROVIDE ACCESS TO ALL ATTIC AREAS.
 ROOF DECK SHALL BE ADEQUATELY DRAINAGE ON EACH SIDE OF THE ROOF DECK.
 METHOD OF WATER REMOVAL FROM ROOF DECK SHALL BE COLLECT AND
 REMOVE ALL ROOF DRAINAGE TO THE GROUND SURFACE AT EACH AND
 EVERY ROOF DRAINAGE POINT. THE ROOF DECK SHALL BE CLEAN AND
 DRAINAGE FREE.
 THE PLAN INDICATES ROOF ACCESS TO THE ATTIC FROM THE
 TO CONSTRUCTION.

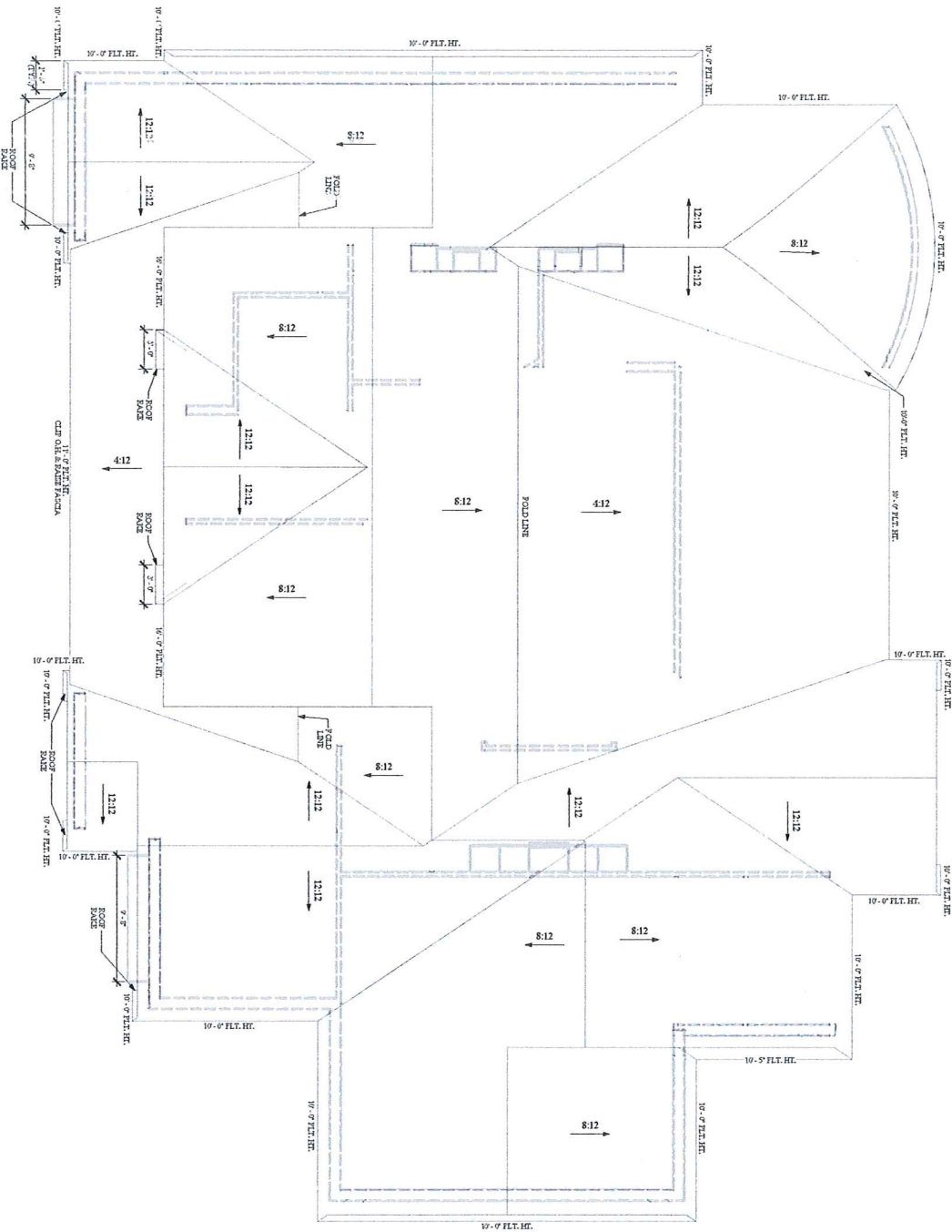

ROOF PLAN

SCALE: 1/4" = 1'-0"

PURDON RESIDENCE
 26232 LAUREN'S COURT
 LOT: 1 BLOCK: 5 SECTION: 1
 MONTGOMERY, TEXAS 77316
 CROWN RANCH

DUNN & STONE
 BUILDERS

REVISIONS	

SCALE	1/4" = 1'-0"
TITLE	ROOF PLAN
DATE	06/09/20
PROJECT	PURDON RESIDENCE
ARCHITECT	

A-5

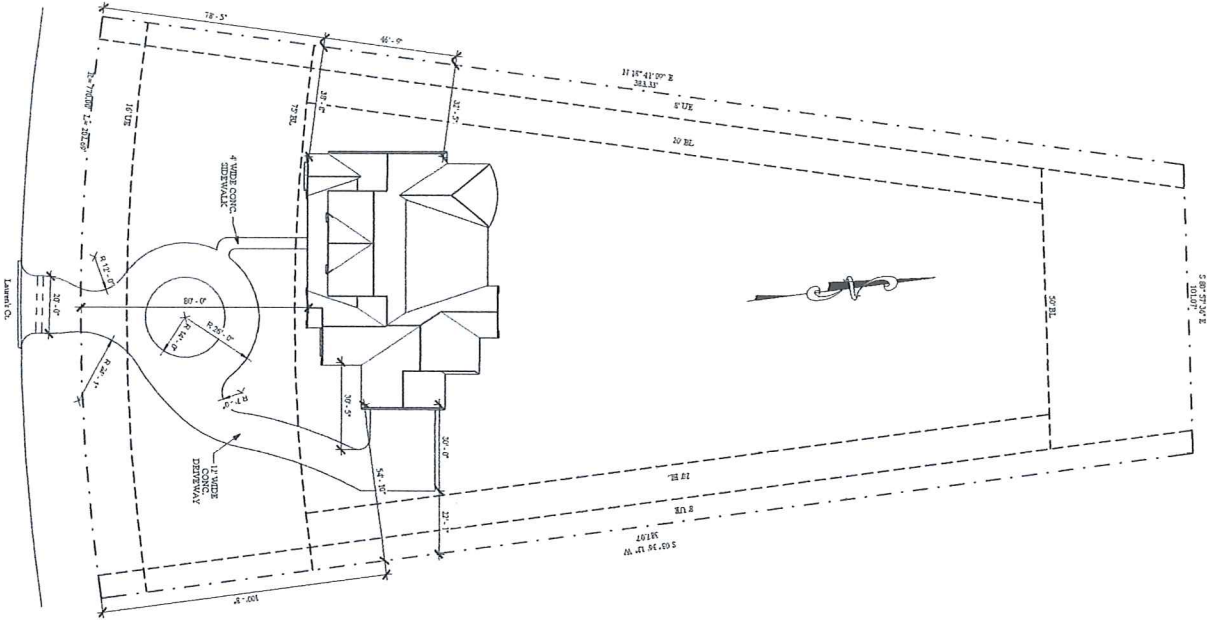

SUBDIVISION
CROWN RANCH

LOT
72

BLOCK
1

SECTION
1

SITE PLAN NOTES:
 - CONFORM TO ALL ORDINANCES, REGULATIONS, AND DEPARTMENTAL ORDERS.
 - VERIFY ALL EXISTING AND PROPOSED UTILITIES PRIOR TO CONSTRUCTION.
 - CHECK LOCAL HEIGHT AND SETBACK REQUIREMENTS.
 - NO TREE REMOVAL REQUIRED.

SITE PLAN
 SCALE: 1" = 20'

PURDON RESIDENCE
 26232 LAUREN'S COURT
 LOT: 1 BLOCK: 5 SECTION: 1
 MONTGOMERY, TEXAS 77316
 CROWN RANCH

TITLE: A-7

**DUNN & STONE
 BUILDERS**

REVISIONS	