

ADDRESS: 6910 HALIFAX HARVEST LANE

AREA: 5,400 S.F. ~ 0.12 ACRES

PLAT NO. 20210210

MFE: 94.80'

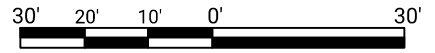

GRAPHIC SCALE: 1" = 30'

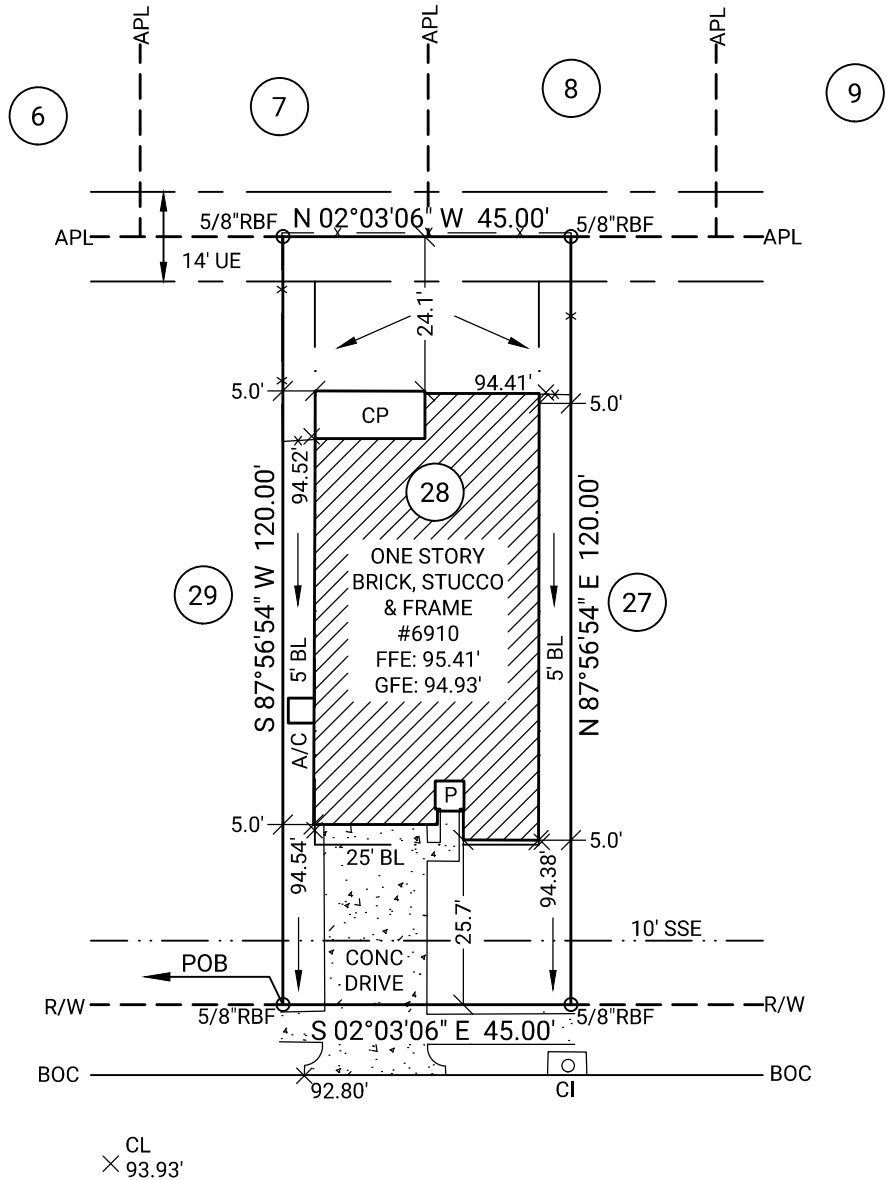
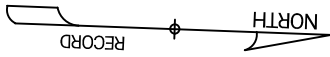

POB
371.25' ALONG THE R/W
TO THE 50' R/W OF
DENSTONE CLIFF WAY

LEGEND

- BL Building Line
- CL Center Line
- APL Approximate Property Line
- BOC Back of Curb
- R/W Right of Way
- N/F Now or Formerly
- UE Utility Easement
- DE Drainage Easement
- SSE Sanitary Sewer Easement
- WLE Water Line Easement
- STMSE Storm Sewer Easement
- PROP Proposed
- POB Point of Beginning
- MFE Minimum Finished Floor Elevation
- FFE Finished Floor Elevation
- GFE Garage Floor Elevation
- P Porch
- CP Covered Patio
- PAT Patio
- CI Curb Inlet
- CONC Concrete
- A/C Air Conditioning
- X- Fence
- TOF Top of Forms
- RBF Rebar Found
- RBS Rebar Set

HALIFAX HARVEST LANE
50' PUBLIC R/W

NOTE: COMMON PRIVACY FENCE CONSTRUCTED BY BUILDER.

GENERAL NOTES: This property is subject to additional easements or restrictions of record. Carter & Clark Surveyors is unable to warrant the accuracy of boundary information, structures, easements, and buffers that are illustrated on the subdivision plat. Utility easement has not been field verified by surveyor. contact utility contractor for location prior to construction (if applicable). This plat is for exclusive use by client. Use by third parties is at their own risk. Dimensions from house to property lines should not be used to establish fences. This plat has been calculated for closure and is found to be accurate within one foot in 10,000+ feet. The field data upon which this plat is based has a closure precision of one foot in 10,000+ feet and an angular error of 7 seconds per angle point and was adjusted using the compass rule. Equipment used: Leica TS13 Robotic Total Station.

SUB: Lakeview Retreat SEC: 12
LOT: 28 BL: 3

City of Houston E.T.J, Fort Bend County,
Texas

FINAL SURVEY FOR:



FIELD WORK DATE: 11/08/2022
20221101908 DRH_HTX_S FC: JE



3090 Premiere Parkway, Suite 600
Duluth, GA 30097
866.637.1048
www.carterandclark.com
FIRM LICENSE: 10193759

In my opinion, this plat is a correct representation of the land platted and has been prepared within the minimum standards and requirements of law.

