

# *Bonterra Sunshine Group*



## *Committee Members*

*Jane Maggart, Chairman of Sunshine TEAM (713)397-8381*

*Pam Ehler, Co-Chairman of Welcome Committee (925)783-0631*

*Carol Key, Co-Chairman of Welcome Committee (972)342-0401*

## *Caregiver Support Group*

*This group provides support to those individuals within the Bonterra Community who are **primary caregivers** to someone within their family that is medically or mentally challenged. This is a wonderful opportunity to either learn or share your ideas on caring for family members.*

*Also, the Organizer of the group, **Len Dodson**, can loan out certain used medical equipment for those in need who reside in Bonterra.*

*Please call any of these Members when you or your Bonterra Neighbors have a question.*

# Bonterra General Resident Information



## LIFESTYLE DIRECTOR:

**Kevin Woods, (936)588-0094**, responsible for:

- ❖ All Lifestyle Events offered at the Clubhouse
- ❖ The Clubhouse Staff
- ❖ The Fitness Spa Staff
- ❖ Group Exercise Classes and Personal Training

## Bonterra HOA:

### HOA Board:

**John Skopak**, President

**Tim Wathen**, Vice-President

**Peggy Webb**, Secretary

**Bill Bailey**, Treasurer

**Debbie Davis**, Director

Contact HOA Board by email: [bod.bwfca@ciaservices.com](mailto:bod.bwfca@ciaservices.com)

## C.I.A. Services:

**C.I.A. Services is the management company for the community**, responsible for the business affairs of the Association, which includes attending the Board meetings, maintaining the Association's records, negotiating contracts, and acting as the liaison between the Board of Directors and the members of the Association. You may contact **Stacey Hitchcock**, General Manager, [stacey.hitchcock@ciaservices.com](mailto:stacey.hitchcock@ciaservices.com) or Administrative Assistant Velissa Pena, [velissa.pena@ciaservices.com](mailto:velissa.pena@ciaservices.com). As our Bonterra Management Company, CIA Services is your contact regarding:

- ❖ ASC-Exterior changes/modifications
- ❖ Deed Restrictions
- ❖ Neighborhood concerns
- ❖ Common areas-walking trails
- ❖ Exterior trash cans & doggie stations
- ❖ Fitness Equipment
- ❖ Landscaping Maintenance
- ❖ Pick ball & Bocce Courts maintenance
- ❖ Pond & Fountain maintenance
- ❖ Pool/Spa questions – temperature settings & maintenance

Phone: 713-981-9000

Email: [customercare@ciaservices.com](mailto:customercare@ciaservices.com)

Or log in to C.I.A. Services Owner App:  
[Myreddog.ciaservices.com](http://Myreddog.ciaservices.com)

#### **WOODFOREST HOA:**

**Cobi Barnett, (936)447-2830**, responsible for:

- ❖ Woodforest Common Area Maintenance
- ❖ Woodforest Pool
- ❖ Woodforest Playgrounds

#### **BONTERRA CLUBHOUSE ASSISTANT LIFESTYLE DIRECTOR:**

**Judy Colbridge, (936)588-0094**

**FACEBOOK PAGE:** Log into Facebook to join these two private groups:

- ❖ **Bonterra 55+ Montgomery Texas**
  - (Private group managed by & for Bonterra Residents ONLY)
- ❖ **Bonterra at Woodforest Lifestyle**
  - (Private group managed by & for Bonterra Residents and Bonterra Management)

#### **BONTERRA LIFE WEB SITE:**

- ❖ Bonterra Life Web Site
  - <http://www.bonterrallife.com>

**BONTERRA WEB SITES:**

- ❖ **Myreddog.ciaservices.com**
  - **Public Documents > Policies & procedures**
- ❖ **Bonterra at Woodforest Web Site**
  - <http://www.ciaservices.com>
  - <http://myreddog.ciaservices.com>
  - <http://www.bwfcommunity.org>
  - **Contact Bonterra Concierge for access to the private Bonterra sites**

**DIRECTORY LIST OF BONTERRA RESIDENTS:** Contact Dick Vermeer  
(936)525-8676

**VENDOR LIST:** Contact Pamela Ehler (925)783-0631

# HOA Information

## Bonterra HOA Management C.I.A.

*Stacey Hitchcock, C.I.A. Services  
General Manager  
Phone: (713)981-9000  
stacey.hitchcock@ciaservices.com*

### *Lifestyle Director*

*Kevin Wood  
Phone: (936)588-0094*

### *Bonterra Clubhouse Assistant Lifestyle Director*

*Judy Colbridge  
(936)588-0094*

\*\*\*\*\*

### *Community Building Access Card Information (Contact Judy):*

- Do not leave your cards in your car. Excessive heat can affect the shape of the cards.*
- Keep your cards away from anything magnetic. such as, the closure to a purse or key chain or certain cell phone batteries, which will demagnetize the cards immediately.*
- Do not bend cards*
- Do not alter your cards in any way. This includes a hole punch.*

*Once you take possession of the cards, they become your responsibility. If your cards are damaged or stop working, you will need to purchase new cards \$25.00 each. Each household is entitled to a total of two access cards.*

### *Sunshine/Welcome Program*

*This program is one whereby current Bonterra neighbors say “Hello” to all of our new residents. A member of this committee will greet new move-ins and provide them with general information on how to access ALL THINGS BONTERRA.*

## *Sunshine/Neighbor to Neighbor*

*Bonterra's Neighbor to Neighbor program was established in May 2022 for the purposes of caring for neighbors on each street. A Street Captain is named, volunteers his/her time and is responsible for maintaining the names, contact information, emergency contact information from those who reside on the street. The Street Captain would also be the lead for any issues of concerns on the street, whether there be a hospitalization, a need to organize a food team, or simply call for a street gathering.*

## *Community E-Blast - Stay Informed*

*These are email messages regarding Bonterra activities sent from the Lifestyle Director. Go to the link below and sign up.*

[\*http://www.bwfcommunity.org\*](http://www.bwfcommunity.org)

\*\*\*\*\*

## *Woodforest HOA Management* *FirstService Residential*

*Mercy Frank, Community Administrator*  
[\*Mercy.Frank@fsresidential.com\*](mailto:Mercy.Frank@fsresidential.com)

*Cobi Barnett, General Manager*  
[\*Cobi.Barnett@fsresidential.com\*](mailto:Cobi.Barnett@fsresidential.com)

*Erin DeMoss, Director of Fun*  
[\*DirectorOfFun@Woodforestdev.com\*](mailto:DirectorOfFun@Woodforestdev.com)

*Woodforest Web Site:*  
[\*http://www.texas.fsrconnect.com\*](http://www.texas.fsrconnect.com)

\*\*\*\*\*

## *2025 Bonterra Assessment (HOA) Information*

<i>Bonterra</i>	<i>\$2,480.00</i>
<i>Woodforest Dues</i>	<i>695.75</i>
<i>Total 2023 HOA Dues</i>	<i><u>\$3,175.75</u></i>

*Your total Assessment is due on January 1<sup>st</sup> of every year and late as of January 31<sup>st</sup>.*

# Online Assessment Payment Options

**To make payment through First Citizens Bank, please follow these instructions:**

**Click the hyperlink: <https://propertypay.firstcitizens.com>**

**Management ID: 3018**

**Association ID for Bonterra at Woodforest CAI: 2152**

**NOTE: You will be asked for your account number to make an online payment. Please reference the account number noted on your profile.**

**\* Recurring payment options are NOT payment plans. All formal payment plans must be reviewed and approved prior to submitting payment(s). Payment Plan forms can be found under Resident Services > Management Office & Forms. Until the form is submitted and approved a payment plan is not in effect.**

**Fees:**

- **Pay by eCheck: No Convenience Fees applicable.**
- **Credit Card or Debit Card: 4% convenience fee.**

**First Citizens Bank Support available at 1-866-800-4656 or [servicepropertypay@firstcitizens.com](mailto:servicepropertypay@firstcitizens.com)**

## **Bonterra 55 Activities**

Please refer to the online Bonterra Monthly Calendar.

**BOCCE BALL:** Thursdays at 7 pm. Contact Dick Vermeer (936)525-8676

**BONTERRA GARDEN CLUB:** Third Monday, 10:30 am each month. Contact Beverly Ingraham (281)787-6966

**BONTERRA, NOW WHAT:** Third Thursday of every month, 1:00 in the Clubhouse. Contact Kathy Graumann (281)727-6989 or Gail Getschman (281)923-9767

**BONTERRA RINGERS:** First, third, fifth Tuesday at 4:00 pm. Contact Dan Boden (832) 259-8864

**BOOK CLUB:** First Thursday of the Month at 7 pm. Contact Linda Powell (832)496-1394

**BUNCO GROUPS:** Contact Concierge

**CAREGIVER SUPPORT GROUP:** Contact Len Dodson (832).671.0980 or [bonterracaringneighbors@yahoo.com](mailto:bonterracaringneighbors@yahoo.com)

**C.E.R.T.:** Contact Karla Dichmann (972)310-9879 or Orbey Edge (281)779-7112

**CIRCLE OF FRIENDS:** Singles get together for fun activities. Contact Betty Vogel (760)505-1839

**DUPLICATE BRIDGE:** Mondays at 6:30 pm. Contact Concierge

**GROUP EXERCISE CLASSES:** Water Aerobics (March through November), Low Impact Aerobics (December through February), Floor Yoga, Chair Yoga and Core Conditioning. Refer to Bonterra Monthly Calendar for most current dates and times.

**HAND AND FOOT:** Tuesdays and Thursday at 12:30 pm

**LADIES TEXAS HOLD EM:** 2<sup>nd</sup> & 4<sup>th</sup> Fridays at 6:30 pm. Contact Sandy Dzleiawa (817)300-2924

**MAHJONG:** Advanced players on Thursday at 1 pm. Anyone on Friday at 1 pm. Contact Neita Evans (281)734-0569

**MAHJONG:** 6:30pm every Monday. Contact: Anita Gurwitz (302) 893-1778

**MEN'S BRIDGE:** Thursdays at 1 pm. Contact Paul Dixon (404)695-4001

**MEXICAN TRAIN:** Wednesday at 1 pm

**MONTHLY LADIES LUNCH GROUP:** Contact Nancy Tullis (281)450-7272 or Barbara Dent (816)225-8986

**MOVIE NIGHT AT THE CLUB:** Third Tuesday of the Month at 6:30 pm

**NEIGHBOR TO NEIGHBOR:** Contact Jane Maggart (713)397-8381

**OPEN BRIDGE:** Monday's at 6:30 pm. Contact Leslie Brewer (281)460-4138

**PICKLEBALL:** Contact David Stringer (907)350-04851

**PINOCHLE:** Mondays at 1 pm

**POOL TOURNAMENTS:**

1 –9-Ball Pool Tournament: 2<sup>nd</sup> Wednesday at 5:30 pm. See Concierge to sign up

2 – 8-Ball Pool Tournament: 4<sup>th</sup> Wednesday & Thursday at 5:30. See Concierge to sign up.

**RESIDENT'S COFFEE:** Morning coffee discussions at the Clubhouse each morning.

**RUMMIKUB:** Sundays from 2 pm to 4 pm. Contact Liz Sandell lizsandell4@gmail.com

**SAMBA:** Second Monday each month at 5 pm. Contact Sandy Emenheiser (410)398-5042

**SAMBA II:** First & Third Mondays 6:00 pm. Paula Chaffin (713) 563-3770

**SHANGHAI:** 1:00 PM Tuesdays. Anita Gurwitz (302) 893-1778

**STITCH & CHAT:** Mondays at 1 pm. Contact Gail Getschman (281)923-9767

**TEXAS HOLD EM POKER:** Every other Thursday of each Month at 6:30 pm. Contact Pete Alford (832)721-1611

**VETERAN'S GROUP:** Interested in joining contact front desk

**WINEAUX CLUB:** Third Friday of each month at 7 pm. Contact Frank & Sharon Allen (928)978-1222

# Waste Management



*Pick up days are Friday*  
<https://www.wm.com>

*New Residents should call Waste Management and reference MUD #113 to establish their own trash service and schedule the delivery of their trash/recycling receptacles: (713)686-6666*

*Just moving in and have some extra boxes? Or maybe even need to get rid of something that will not fit inside of your garbage can? Our trash service company Waste Management will collect that for you on our regular maintenance day. For the Bonterra Community our regular trash service day is Fridays. We have two trash trucks that uses a claw to come and pick up the garbage/recycle bins. It is followed by a trash truck that will pick up 2 items that are considered heavy trash pick-up.*

*Things that are included in the category of Heavy Trash Pick-Up are:*

- 1. Only 2 items per household are allowed for Heavy Trash Pick-Up.*
- 2. Boxes that are flattened and tied or taped together (must not be bigger than 3 by 3 feet)*
- 3. Furniture (Couches, Love Seats, Dish Washers, Dryers, Appliances) However if it is something that requires Freon, in order to place it out on the street the Freon would need to be removed and the appliance has to be tagged with a tag stating the freon, was removed by a certified technician.*
- 4. Residents are allowed up to 3 trash bags next to the trash cans. This is not considered a part of your 2 heavy bulk trash items.*

*Things that are **NOT** included in Heavy Trash Pick-Up are:*

- 1. Electronics (Computers, Lap-Tops, TV's, etc.)*
- 2. Hazardous Waste (Motor Oil, Engine Parts, Freon, etc.)*

3. *Construction Debris (Carpeting, Brick, Rock, Dirt, Roofing, Lumber, Glass, Tile, etc)*

*If there is a specific item that is not listed in this article you may give Waste Management a call to determine if it is allowed to be placed for Bulk Trash Pick-Up. Contact information, listed below. As well as a request for bulk trash pick-up link. The link is not required by Waste Management, but by the Homeowners Association. This way we are certain your bulk trash will be picked up on the regular maintenance day, Friday.*

*If for any reason your trash was missed, you may contact Waste Management to schedule it to be picked up. Upon calling about a missed trash pick-up, they will pick it up either the same day as called or by noon the following day.*

**Contact Information for Waste Management and Link for Request Bulk Pick-Up:**

**Phone Number: (713)686-6666**

**Website: [www.wm.com](http://www.wm.com)**

**Link: <https://www.wm.com/myaccount/reportProblem.do?action=bulkPickupRequest>**

## *Lawn Maintenance with NATIVE*



*Front yard lawn maintenance is included in your HOA dues. If you have issues please call Velissa Pena, administrative Asst, (713)981-9000*

# BONTERRA<sup>®</sup>

## AT WOODFOREST

### Approved Fence Stain Colors

*In order from left to right in the photo below:*

1. *Behr Premium Transparent - Antique Oak T-171*
2. *Behr Premium Semi Transparent - Wrangler Brown ST-109*
3. *Behr Premium Semi Transparent - Chestnut ST-110*
4. *Sherwin Williams Woodscapes Semi Transparent - Woodridge SW 3504*
5. *Sherwin Williams Woodscapes Semi Transparent - Hawthorne SW3518*
6. *T-500 Natural Clear Transparent Waterproofing Exterior Wood Finish*

*If you are using a clear coat that is un-pigmented, there is no need to make application to the Architectural Review Committee (ARC). If there is any pigmentation to your stain, you MUST apply via the ARC Application.*

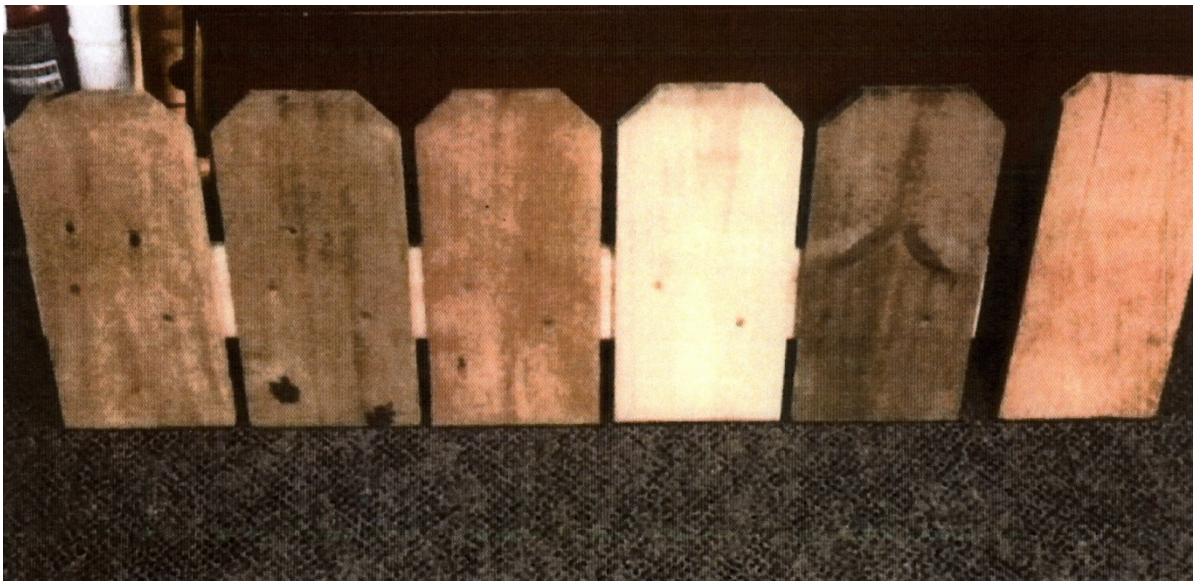

*If you have any questions, please contact Velissa Pena, administrative Asst, (713)981-9000*

# Suggested Plant List (Front Yards)



## Canopy Trees

Birch  
Dogwood  
Eastern Redbud  
Magnolia  
Maple (*Red, Silver, Japanese*)  
Oak (*Live, Nuttall, Sawtooth, Water, etc*)  
Pine  
Sweet Gum  
Sycamore  
Willow

## Shrubs & Ornamental Plants

Azalea  
Bottlebrush  
Crepe Myrtle  
Gardenia (*dwarf*)  
Indian Hawthorn (*dwarf clara*)  
Loropetalum Plum Delight  
Nandina  
Pittosporum (*dwarf*)  
Plumbago  
Rose (*knockout*)

Spirea (*bridal leaf, pink*)  
Texas Sage  
Viburnum  
Yaupon  
Yaupon Holly

## Ground Cover

Honeysuckle  
Jasmine (*Asiatic, Carolina, confederate*)  
Miscanthus Grasses  
Muhly Grass  
Society Garlic

## Flowering Plants

Big Blue  
Chinese Fringe  
Day Lily  
Lantana  
Lily of the Nile (*agapanthus*)  
Primrose Jasmine  
Rose (*knockout, antique*)  
Verbena

# Irrigation System Winterizing

**TURN MAIN VALVE FOR SPRINKLERS OFF AT CURB .**The sequence detailed below will drain water from the backflow device to prevent freezing. Once the backflow device has been drained it is suggested to run the irrigation system through a manual cycle to relieve any water pressure in the pipe draining them slightly.

Tools required: straight blade screw driver

## WINTERIZING YOUR SPRINKLER SYSTEM BACKFLOW DEVICE

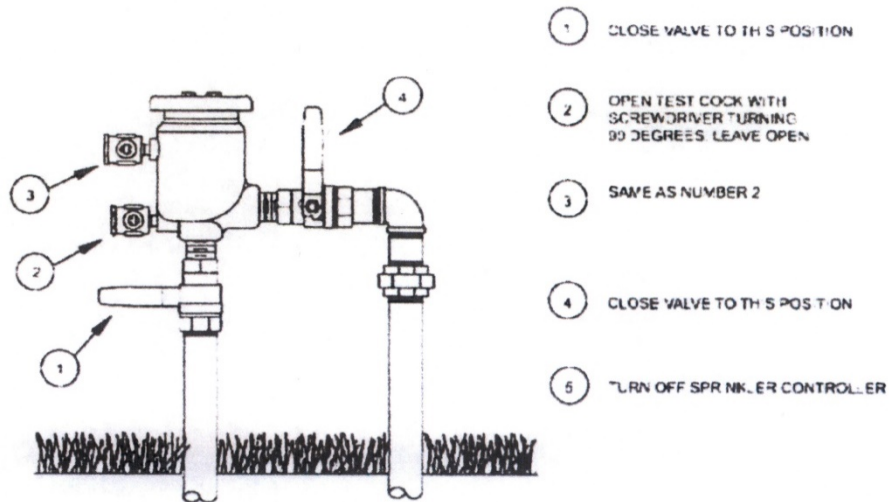

### TO REPRESSURE IRRIGATION SYSTEM

CLOSE #2 & #3 TEST COCKS  
KEEP VALVE #4 CLOSED  
SLOWLY OPEN VALVE #1 UNTIL A SMALL AMOUNT OF WATER COMES OUT FROM UNDER BELL AND YOU HEAR THE CHECK VALVE SCAT. THEN OPEN FULLY  
SLOWLY OPEN VALVE #4 UNTIL MAINLINE BECOMES FULLY PRESSURIZED  
SET SCHEDULE ON SPRINKLER CONTROLLER AND TURN ON

## PRESSURE VACUUM BREAKER

# *US Postal Service Offices*

*Montgomery Postal*  
20821 Eva St. #H  
Montgomery, TX 77356

*Conroe Postal*  
809 W. Dallas Street  
Conroe, TX 77301



## *Important Numbers*

### *Emergency*

*Montgomery County Sheriff Dept*

*Vacation Watch Sheriff*

*Mid-South Synergy*

*Consolidated Communications*

*Texas Gas, LLC*

*Waste Management*

*MOC (Call to set up sewer)*

*The Club at Bonterra*

*Woodforest FIRE Department*

*Woodforest Golf Club*

### **911**

(936)760-5800 (non-emergency)

(936)760-5800

(936)825-5100

(866)989-2255

(281)252-6700

(713)686-6666

(281)367-5511

(936)588-0094

(936)588-2222 (non-emergency)

(936)588-8800

## *Architectural Review Committee*

*All improvements need to be submitted to the Architectural Review Committee (ARC) for approval. To obtain an ARC Application contact your C.I.A. Services TEAM. Contact: [acc@ciaservices.com](mailto:acc@ciaservices.com)*

## *Report Street Light Outage:*

*Contact: Mid-South Synergy (936)825-5100*

*Or contact C.I.A. Services with the light pole number*



## *Garage Sales*

*Community garage sales are held Bi-annually. Once in the Spring and once in the Fall. Homeowners will be notified via email of the date prior to the event. Individual Garage Sales are prohibited any other time.*

## *The Club at Bonterra Pool Schedule*

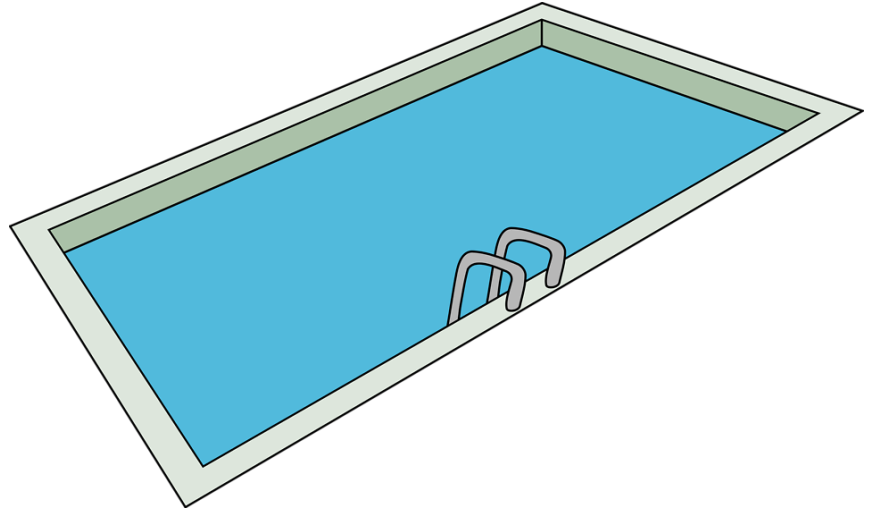

*The pool will be heated during the months of March, April, October, and November.*

*No one under age 19 allowed.*

*The Hot Tub will be heated all year round unless closed for maintenance or repair.*

*For questions regarding the Water Aerobics Classes, contact your Lifestyle Director.*

## *Gate Code Information*

<i>Bonterra Gate Code:</i>	<i>421</i>
<i>Lily Pad Splash Pad:</i>	<i>512</i>
<i>Scooter Park Restroom Code:</i>	<i>512</i>
<i>Christine Allen Park Restroom Code</i>	<i>512</i>

# *Forest Island Pool Schedule*

*(For ALL ages)*

*June 2<sup>nd</sup> - August 14<sup>th</sup>*  
*Monday - Closed for Cleaning*  
*Tuesday - Saturday 10:00 am - 8:00 pm*  
*Sunday 12:00 pm - 8:00 pm*  
*September - Saturday & Sunday ONLY*

*FREE Wi-fi at Pool: Password (Guest)*

## *Pool Party Reservations for Woodforest*



*Blue Water Recreations, Management*  
*Email Hannah at:*  
[Events@bwrecservices.com](mailto:Events@bwrecservices.com)

## *Woodforest Events/Communications*

*Download the Woodforest App*  
*(found in Apple App Store under Woodforest Lifestyle, it's FREE)*  
*For all Park Reservations & Gate Codes*

*Keep up with Events and so much more!!!*